

General Description

The Micrel MIC79110 is a simple and accurate lithium ion battery charger. Featuring a built-in pass transistor, precision programmable current limiting ($\pm 5\%$), and precision voltage termination ($\pm 1.5\%$ over temperature) all in a very small package, the MIC79110 packs full functionality into a small space.

Other features of the MIC79110 include two independent end-of-charge indications, including a digital indication that is programmable with a resistor-to-ground and an analog current output that is proportional to the output current, allowing for monitoring of the actual charging current. Additional features include very low dropout (500mV over the temperature range), thermal shutdown, and reverse polarity protection. In the event the input voltage to the charger is disconnected, the MIC79110 also provides minimal reverse-current and reversed-battery protection.

Available in both fixed 4.2V and adjustable outputs, the MIC79110 is offered in the leadless 3mm x 3mm MLF-10 with an operating junction temperature range of -40°C to $+125^{\circ}\text{C}$.

Features

- Input voltage range: 2.5V to 16V
- High output voltage accuracy of $\pm 0.75\%$ over -5°C to $+60^{\circ}\text{C}$ and $\pm 1.5\%$ over temperature
- Current Limit $\pm 5\%$ accurate from $-5^{\circ}\text{C} \leq T_j \leq +125^{\circ}\text{C}$
- Programmable End-of-Charge Flag
- Analog output proportional to output current
- Adjustable and Fixed 4.2V Output
- Low dropout voltage of 500mV at 700mA load, over temperature
- 1.2A output current
- Excellent line and load regulation specifications
- Reverse current and reverse battery protection
- Thermal shutdown and current limit protection
- Tiny 3mm x 3mm MLF™-10 package
- Junction Temperature Range: -40°C to $+125^{\circ}\text{C}$

Applications

- Cellular phones
- PDAs
- Digital cameras
- Camcorders
- MP3 players
- Notebook PCs
- Portable Meters
- Cradle chargers
- Car chargers
- Battery packs

Typical Application

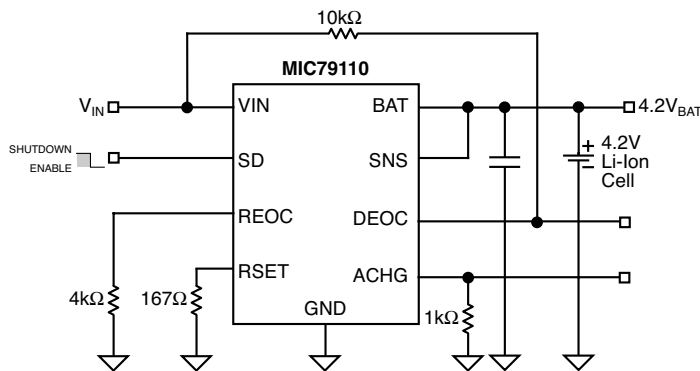

Ordering Information

Part Number	Voltage	Marking	Junction Temp. Range	Package
MIC79110-4.2BML	4.2V	L942	-40°C to +125°C	10-lead 3mm x 3mm MLF™
MIC79110BML	ADJ	L9AA	-40°C to +125°C	10-lead 3mm x 3mm MLF™

Pin Configuration

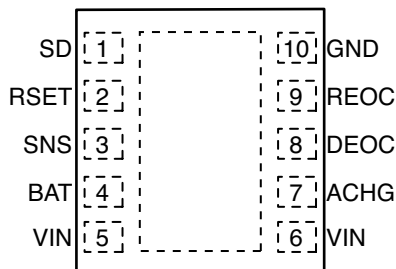

3mm x 3mm Fixed Output

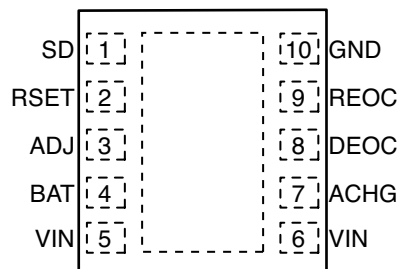

3mm x 3mm Adjustable Output

Pin Description

Pin Number	Pin Name	Pin Function
1	SD	Shutdown Input. Logic High = Off; Logic Low = On
2	R _{SET}	Current limit: Sets constant current limit threshold via an external resistor to ground. $I_{R_{SET}} = (0.2V/R_{SET}) \times 1000$
3	SNS	(Fixed voltage only): Sense output, connect directly to battery
3	ADJ	(Adjustable voltage only): Feedback input.
4	BAT	Battery Terminal. Connect to single-cell lithium-ion battery.
5, 6	V _{IN}	Input supply pin.
7	A _{CHG}	Analog Charge Indicator Output: Current source output equal to 1/1000th of the output current.
8	D _{EOC}	Digital End-of-Charge Output: N-Ch open drain output. Low indicates charging, a current that is higher than the programmed current set by R _{EOC} is charging the battery. When the current drops to less than the current set by R _{EOC} , the output goes high impedance, indicating end-of-charge.
9	R _{EOC}	End-of-Charge Set: Sets end-of-charge current threshold via an external resistor to ground. $I_{EOC} = (0.2V/R_{EOC}) \times 1000$
10	GND	Ground

Absolute Maximum Ratings (1)

Input Supply Voltage (V_{IN})	0V to 18V
Shutdown Input Voltage (V)	0V to 18V
Output Voltage (ADJ)	10V
Power Dissipation	Internally Limited
Junction Temperature	-40°C to +125°C

Operating Ratings (2)

Input Supply Voltage	2.5V to 16V
Shutdown Input Voltage (V)	0V to 7V
Output Voltage (ADJ)	9.6V
Junction Temperature Range (T_J)	-40°C to +125°C
θ_{JA} (MLF™-10)	60°C
θ_{JC} (MLF™-10)	2°C

Electrical Characteristics

$T_A = 25^\circ\text{C}$ with $V_{IN} = V_{OUT} + 1\text{V}$; $I_{LOAD} = 100\mu\text{A}$; $C_{BATT} = 10\mu\text{F}$; $SD = 0\text{V}$; $R_{SET} = 1\text{k}\Omega$. **Bold** values indicate $-40^\circ\text{C} < T_J < +125^\circ\text{C}$; unless otherwise specified.

Parameter	Condition	Min	Typ	Max	Unit
Output Voltage Accuracy	Variation from $V_{OUT} = 4.2\text{V}$; $T_J = -5^\circ\text{C}$ to $+60^\circ\text{C}$; $I_{Load} = 50\text{mA}$	-0.75		+0.75	%
		-1.5		+1.5	%
ADJ Pin Voltage Accuracy		0.5955	0.6	0.6045	V
Line Regulation	$V_{IN} = V_{out} + 1\text{V}$ to 16V @ $I_{LOAD} = 50\text{mA}$	-0.1		+0.1	%/V
Load Regulation	$I_{LOAD} = 0.1\text{mA}$ to 1A		0.3		%
Dropout Voltage ⁽³⁾	$I_{LOAD} = 100\text{mA}$, $R_{set} = 167\Omega$		160	250	mV
	$I_{LOAD} = 700\text{mA}$, $R_{set} = 167\Omega$		375	550	mV
Ground Current	$I_{LOAD} = 10\text{mA}$, $R_{set} = 167\Omega$		2	3	mA
	$I_{LOAD} = 700\text{mA}$, $R_{set} = 167\Omega$		24	35	mA
V_{IN} Pin Current	$SD = V_{IN}$		120	300	μA
Shutdown Pin Current	$SD = 5.2\text{V}$, $V_{BAT} = 0$		0.1	5	μA
Shutdown Input Threshold	Logic High, regulator off	1.1			V
	Logic Low, regulator on			0.9	V
Shutdown Hysteresis			60		mV
Current Limit Accuracy ^(4, 5)	$V_{OUT} = 0.9 \times V_{NOM}$; $I_{OUT} = 1.2\text{A}$, $R_{SET} = 167\Omega$, $T_J = -40^\circ\text{C}$ to $+85^\circ\text{C}$	-5		+5	%
	$V_{OUT} = 0.9 \times V_{NOM}$; $I_{OUT} = 0.1\text{A}$, $R_{SET} = 2\text{k}\Omega$	-20		+20	%
Current Limit Setpoint Range ⁽⁵⁾		0.1		1.2	A
Maximum Current Limit	R_{SET} shorted to ground, $V_{BAT} = 0.9 \times V_{NOM}$	1.25	1.65	2.5	A
V_{BAT} Reverse Current	$V_{IN} = \text{High impedance or ground}$		4.2	20	μA

Digital End-of-Charge (D_{EOC}) Output

I_{EOC} ^(6, 7)	$R_{EOC} = 4\text{k}\Omega$ Current Falling	35	50	65	mA
		30		70	mA
I_{EOC} ^(6, 7)	$R_{EOC} = 4\text{k}\Omega$ Current Rising	50	70	95	mA
		40		100	mA
D_{EOC} Logic-Low Voltage	$I_{DEOC} = 5\text{mA}$, $I_{BAT} = 700\text{mA}$		0.74	0.95	V
D_{EOC} Leakage Current	Logic High = $V_{IN} = 16\text{V}$		0.1		μA
D_{EOC} On Resistance	$V_{IN} = +5\text{V}$		150	190	Ω
R_{EOC} Maximum Current Limit	R_{EOC} shorted to ground	0.5	1.0	2.0	mA

Analog Charge Indicator (A_{CHG}) Output

I_{SOURCE} ⁽⁸⁾	$I_{BAT} = 50\text{mA}$	45	46	55	μA
	$I_{BAT} = 1.2\text{A}$, $T_J = -40^\circ\text{C}$ to $+85^\circ\text{C}$	800	950	1150	μA

Notes:

- Exceeding the absolute maximum rating may damage the device.
- The device is not guaranteed to function outside its operating rating.

3. Dropout Voltage is defined as the input to output differential at which the output voltage drops 2% below its nominal value measured at 1V differential. For outputs below 2.5V, dropout voltage is the input-to-output voltage differential with the minimum input voltage 2.5V. Minimum input operating voltage is 2.5V.
4. V_{nom} denotes the nominal output voltage.
5. $I_{R_{SET}} = (0.2V/R_{SET}) * 1000$
6. Output Current I_{EOC} when Digital End-of-Charge output goes high impedance. Currents greater than I_{EOC} , the D_{EOC} output is low, currents lower than I_{EOC} , D_{EOC} is high impedance.
7. $I_{EOC} = (0.2V/R_{EOC}) * 1000$
8. I_{SOURCE} is the current output from A_{CHG} pin. A resistor to ground from the A_{CHG} pin will program a voltage that is proportional to the output current.

Block Diagram

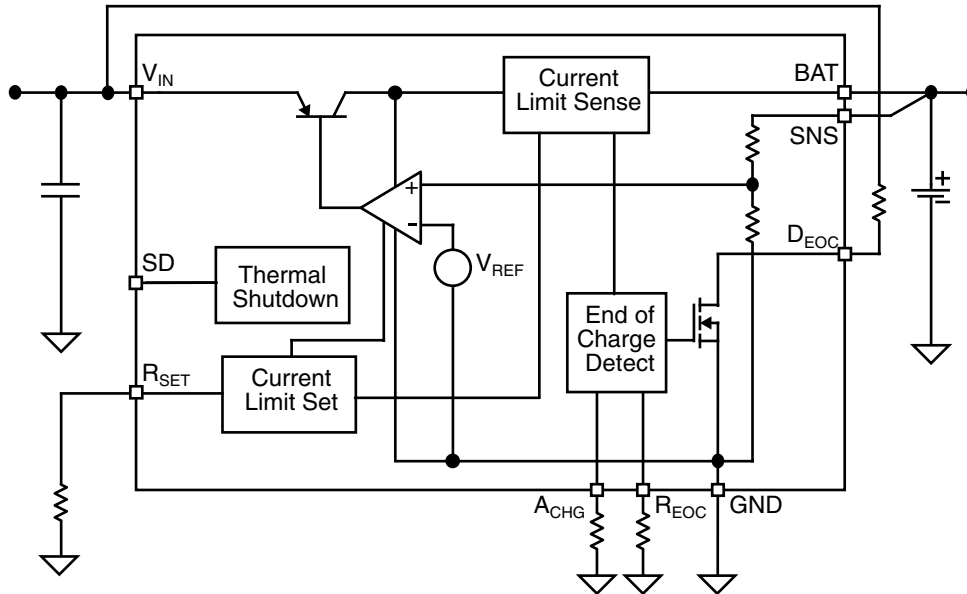

MIC79110 Block Diagram

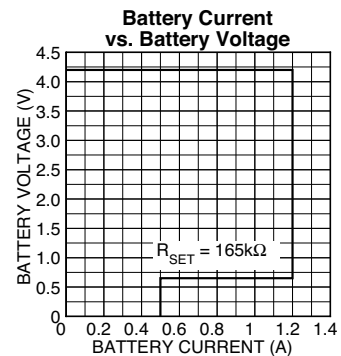
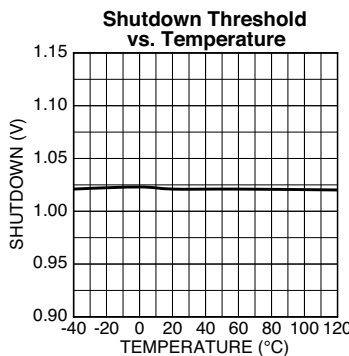
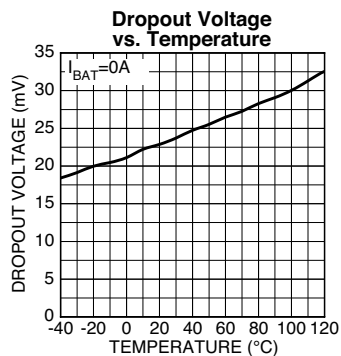
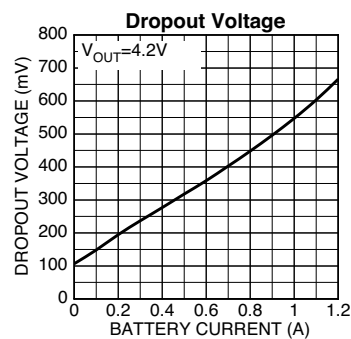
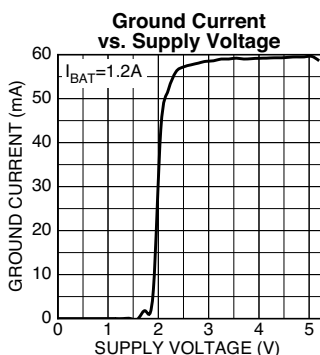
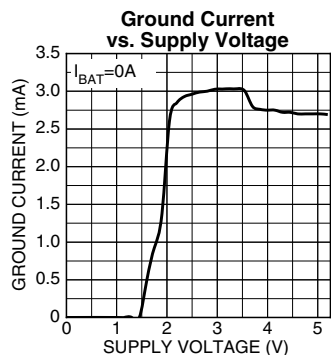
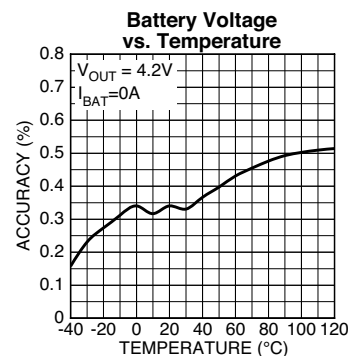
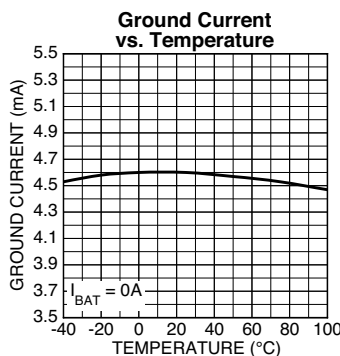
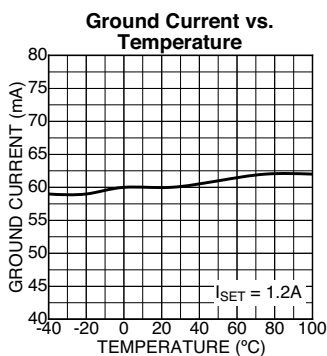
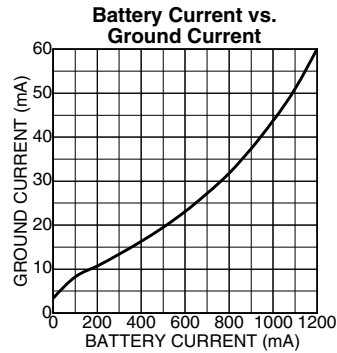
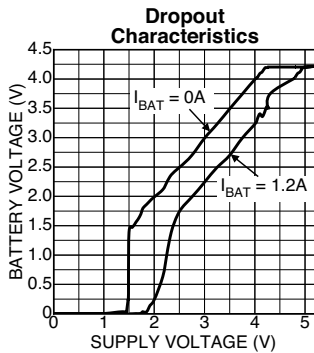
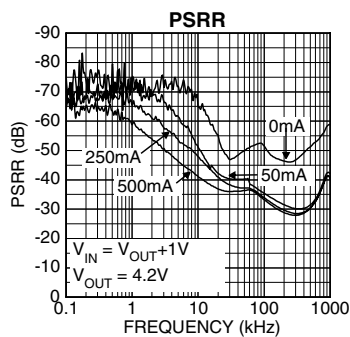

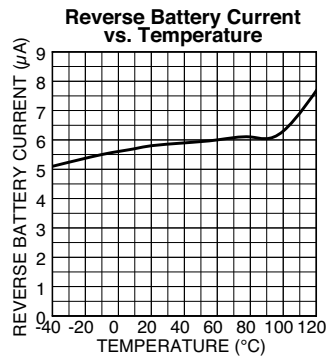
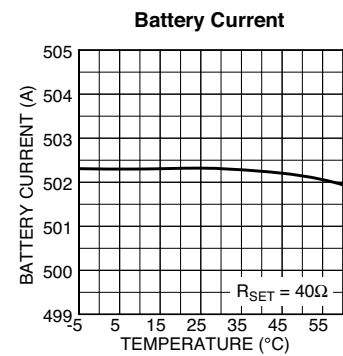
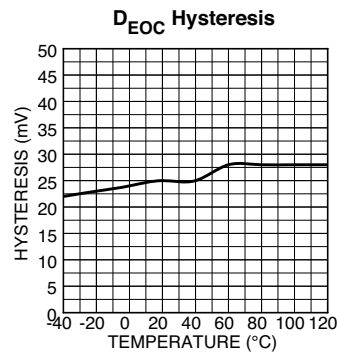
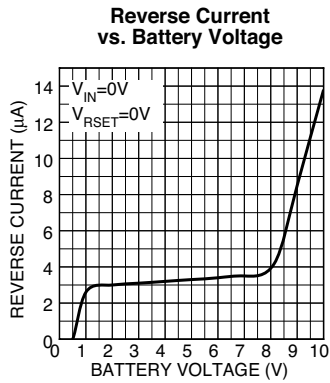
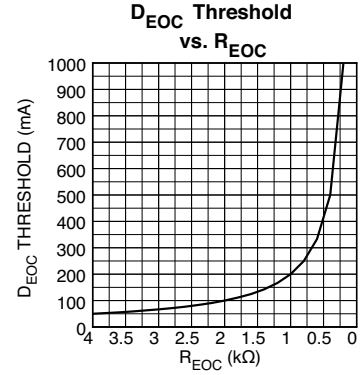
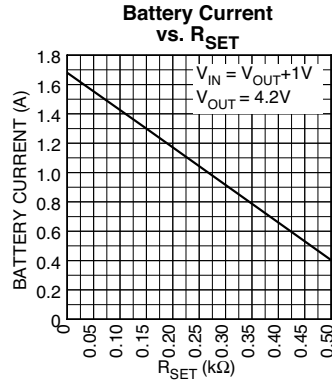
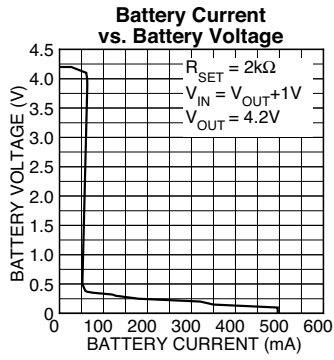

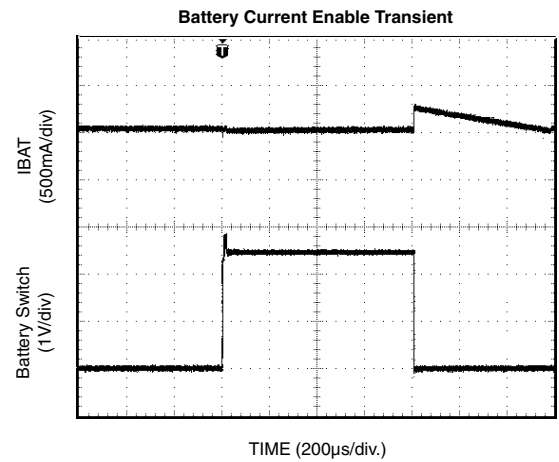
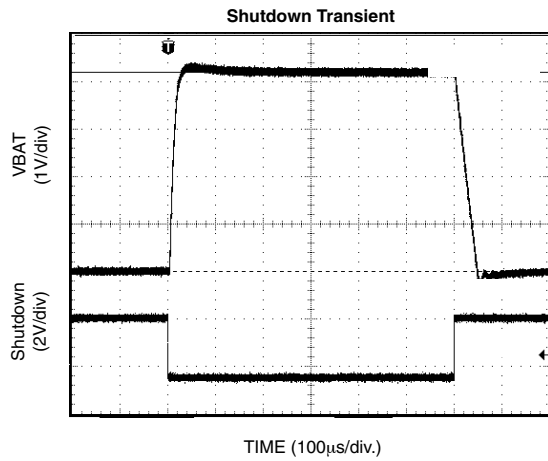
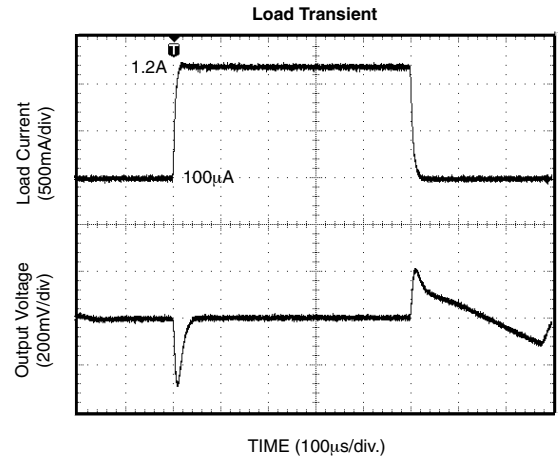
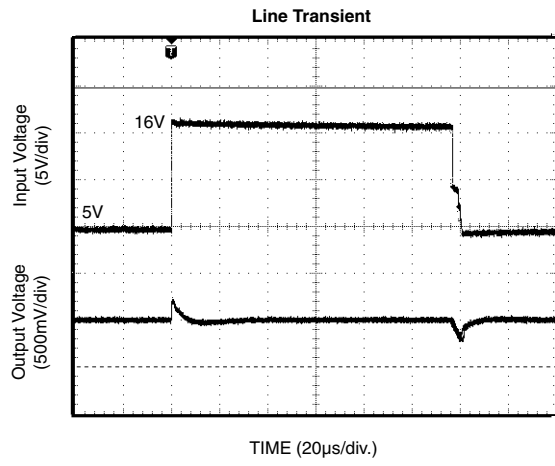

Application Information

Detailed Description

The MIC79110 forms a complete charger for 1-cell Lithium-ion batteries. It includes precision voltage control (0.75% over temperature) to optimize both cell performance and cycle life. All are compatible with common 4.2V Lithium-ion chemistries. Voltages other than 4.2V can be obtained with the adjustable version. Other features include current limit, end-of-charge flag and end-of-charge current limit using an external resistor. The shutdown pin enables low quiescent current when not charging.

Current Limit Mode

MIC79110 features an internal current limit that is set by the Rset pin with a resistor-to-ground. The maximum current is calculated by the following equation:

$$I_{R_{set}} = (0.2/R_{set}) \times 1000$$

Using a 167Ω R_{set} resistor will achieve the maximum current limit for the MIC79110 at 1.2 amperes.

End of Charge

REOC pin is connected to a resistor-to-ground. This resistor is used to set the end of charge current for the lithium ion battery as follows:

$$I_{R_{EOC}} = (0.2/R_{EOC}) \times 1000$$

Using a 4kΩ R_{EOC} resistor will set the end-of-charge current at 50mA.

I_{reoc} should be set at 10% of the battery's rated current.

Digital End-of Charge Output

This pin is the output of an open drain. When tied high to the supply using a resistor, the output will toggle high or low depending on the output current of I_{bat}.

- Low state indicates that the I_{bat} current is higher than the programmed current set by REOC.
- High state indicates that the I_{bat} current is lower than the programmed current set by REOC. The output goes high impedance indicating end-of-charge.

Analog-End-Of-Charge Output

The ACHG pin provides a small current that is proportional to the charge current. The ratio is set at 1/1000th of the output current.

Shutdown

The SD pin serves as a logic input (active low) to enable the charger.

Built-in hysteresis for the shutdown pin is 50mV over temperature.

Reverse Polarity Protection

In the event that V_{BAT} > V_{IN} and the shutdown pin is active low, there is reverse battery current protection built in. The current is limited to less than 10μA over temperature.

Constant Output Voltage/Current Charging

The MIC79110 features constant voltage and constant current output to correctly charge lithium-ion batteries. The constant voltage is either 4.2V or adjustable. The constant current is set by the Rset pin and is constant down to around 300mV. Since Rset can be set below 500mA, the minimum output current is set at 500mA for output voltages below 100mV. This minimum voltage starts the charging process in lithium-ion batteries. If the output current is too low, the battery will not begin charge.

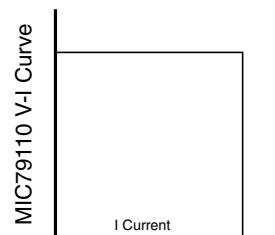

Standard V-I Curve

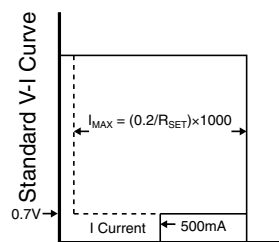

MIC79110 V-I Curve

Lithium Ion Batteries

Lithium-ion batteries are charged in two stages to reach full capacity. The first stage charges the battery with maximum charge current until 90% of the battery cell's voltage limit is reached. The second stage tops off the charge with constant voltage charge as the charge current slowly decreases. End of charge is reached when the current is less than 3% of the rated current. A third stage will occasionally top off with charge with constant voltage charge if the battery voltage drops below a certain threshold.

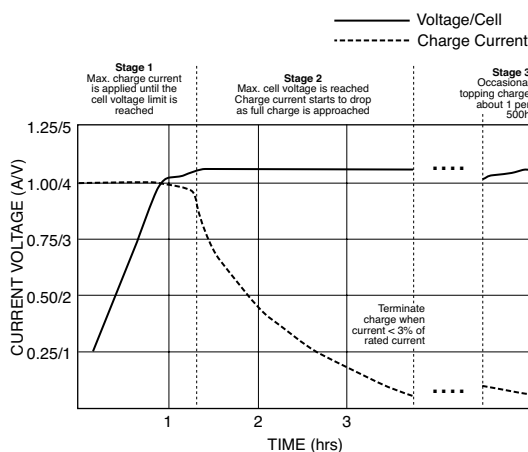

All lithium-ion batteries take approximately 3 hours to charge with the second stage taking twice as long as the first stage. Some chargers claim to be fast chargers by skipping the second stage and just charges the battery until the cell voltage is reached. This only charges the battery to 70%

capacity. An increase in the charge current during stage 1 does not shorten the total charge time. It will only shorten the time for stage 1 to complete and lengthen the time in stage 2.

The lithium-ion loses charge due to aging whether it is used or not. Do not store the batteries at full charge and high heat because it will accelerate the aging process. Try and store with 40% charge and in a cool environment.

Lithium-Ion Safety Precautions

Every lithium ion battery pack should have a safety board which monitors the charge and discharge of the pack and prevents dangerous occurrences. The specifications of these safety boards are dictated by the cell manufacturer and may include the following:

- Reverse polarity protection
- Charge temperature must not be charged when temperature is lower than 0°C or above 45°C.

- Charge current must not be too high, typically below 0.7C
- Discharge current protection to prevent damage due to short circuits.
- Protection circuitry for over voltage applied to the battery terminals.
- Overcharge protection circuitry to stop charge when the voltage per cell rises above 4.3V.
- Over discharge protection circuitry to stop discharge when the battery voltage falls below 2.3V (varies with manufacturer).
- Thermal shutdown protection for the battery if the ambient temperature is above 100°C.

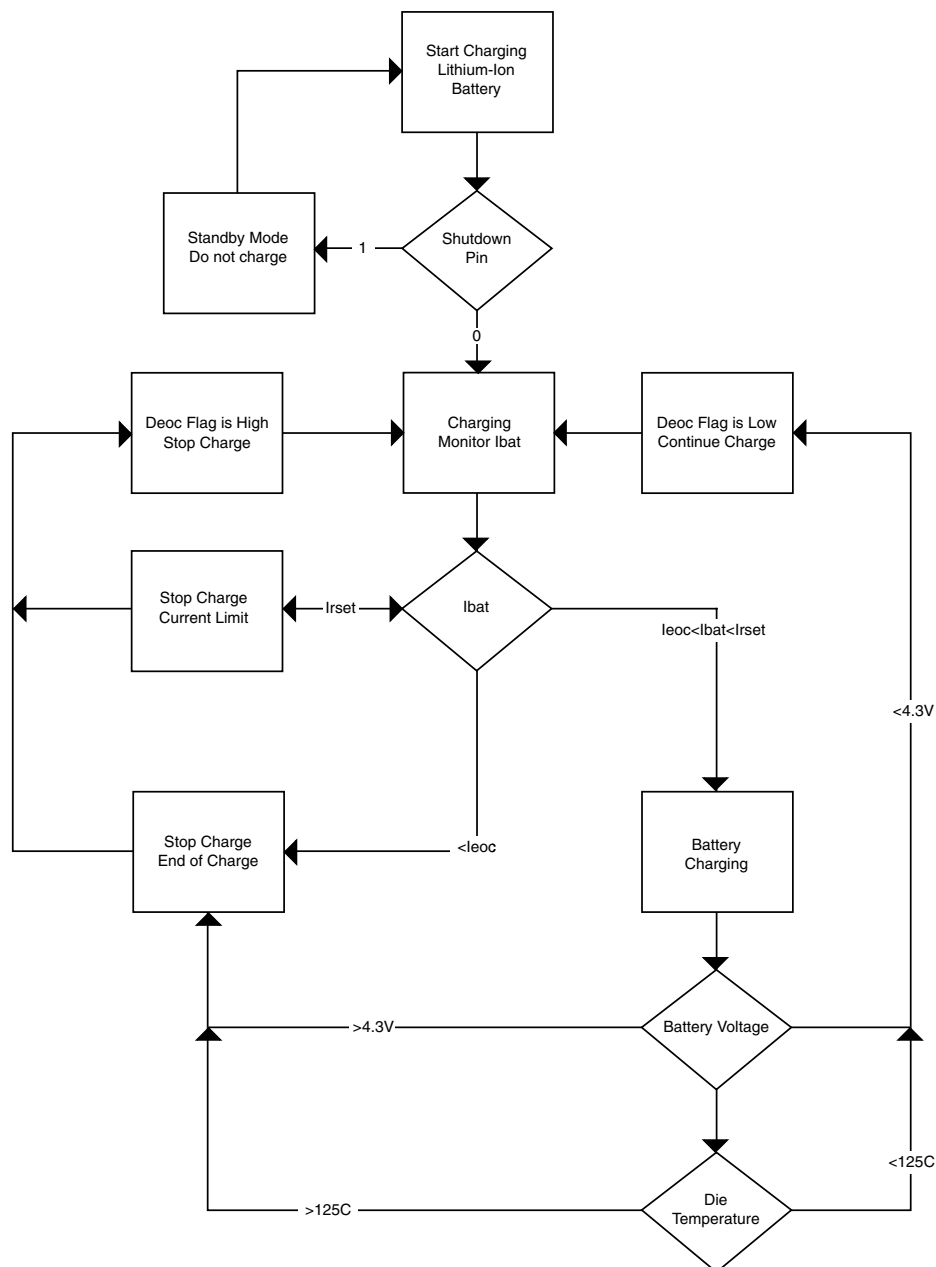

Simple Charger - External Trigger to Reset Charge Cycle reset

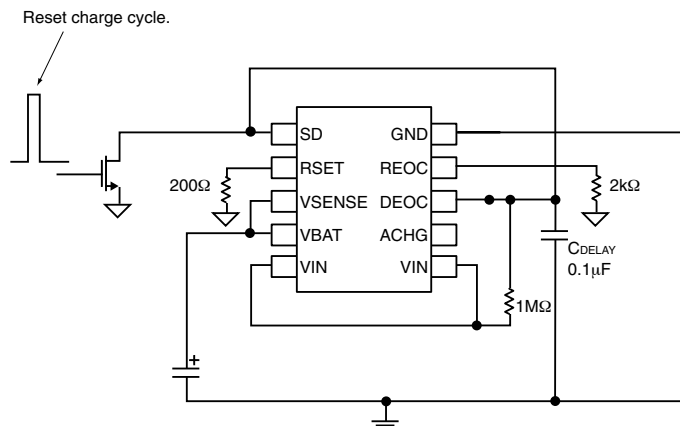

The V_{IN} voltage steps up to a voltage greater than V_{BAT} . When V_{in} is below V_{bat} , the I_{bat} current is near zero and the reverse shutoff circuit is turning the charge to the battery off. The I_{BAT} slowly increases as V_{IN} rises above V_{BAT} . D_{EOC} is pulled low when the I_{bat} current is above the I_{EOC} current set by R_{EOC} . When the D_{EOC} is low, the shutdown pin is also forced low and helps discharge C_{SD} . When the V_{BAT} reaches the set voltage, the I_{bat} begins to slowly drop. When the I_{bat} is less than the I_{EOC} threshold, the D_{EOC} output goes high impedance, indicating end-of-charge. When an external signal is applied to the gate, the external N_{CH} pulls the SD and DEOC pins to ground. This restarts the charging process.

External Trigger to Reset Charge Cycle Reset

- 1 - V_{IN} steps up to a voltage greater than V_{BAT} .
- 2 - SD held low by C_{SD} until active high D_{EOC} pulls shutdown low.
- 3 - Deoc releases SD, resistor pull-up from SD pin to V_{IN} pulls V_{SD} to V_{IN} .
- 4 - An external signal applied to the gate of the external N_{CH} pulls SD pin-to-ground.
- 5 - $I_{battery}$ is near zero (2 to 4μA) because V_{IN} is below V_{BAT} and the reverse shutoff circuit is turning the charge to the battery off.
- 6 - I_{BAT} is decreased as V_{BAT} approaches V_{BAT} set voltage. I_{BAT} decreases below the D_{EOC} threshold and D_{EOC} is released high allowing V_{SD} to go high
- 7 - External N_{CH} turns part on, after a small delay I_{BAT} turns on.
- 8 - Active high DEOC pin goes high because of reverse shutoff. D_{EOC} remains high until I_{BAT} exceeds D_{EOC} threshold, then goes low.
- 9 - I_{BAT} decreases below (see #5) D_{EOC} threshold.
- 10 - Active low D_{EOC} is high because V_{IN} is below V_{BAT} and reverse shutoff holds D_{EOC} comparator off. As V_{IN} increases above V_{BAT} , the reverse voltage shutoff turns off, D_{EOC} comparator becomes active. While I_{BAT} is below D_{EOC} threshold D_{EOC} active low goes low, when I_{BAT} exceeds D_{EOC} threshold I_{BAT} goes high.
- 11 - Legitimate Activation of active low D_{EOC} until SD shuts down part and D_{EOC} AL (active low) goes high.

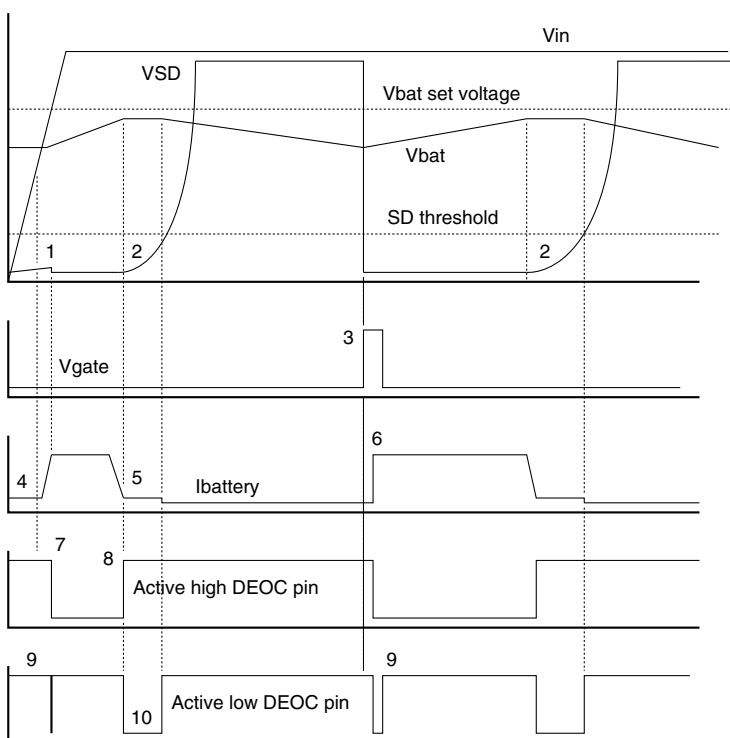

Auto Top Off Charger - Application Circuit

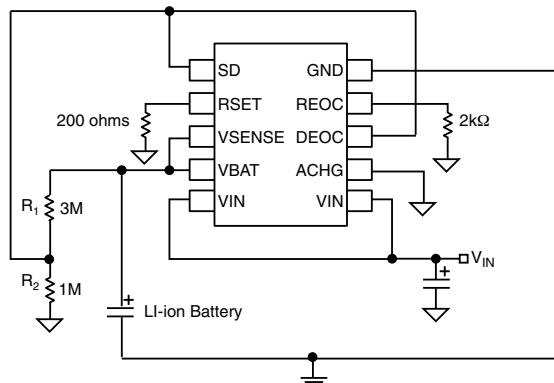

Lithium-Ion batteries will begin to lose their charge over time. The MIC79110 can be configured to automatically recharge the battery if the voltage drops below a certain voltage. This minimum voltage is set by a resistor divider at the battery and connected to the SD pin. When the battery voltage falls below the minimum voltage, the SD pin is pulled low to start the normal charging process.

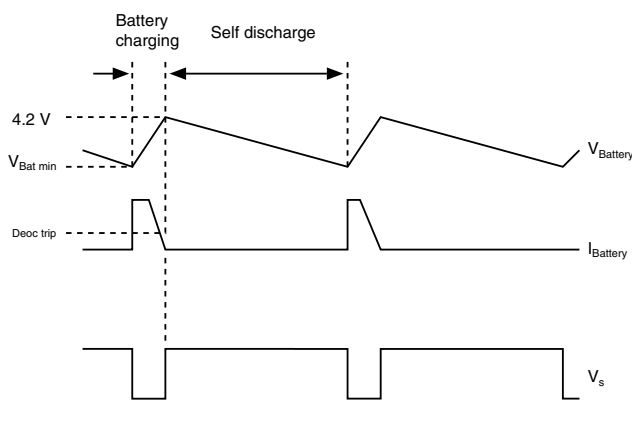

$$V_{Bat\ min} = 0.975V \left(\frac{R_1}{R_2} + 1 \right) \quad R_2 = 1\text{meg} \quad R_1 = \left(\frac{V_{Bat\ min}}{0.975} - 1 \right) \frac{1}{R_2}$$

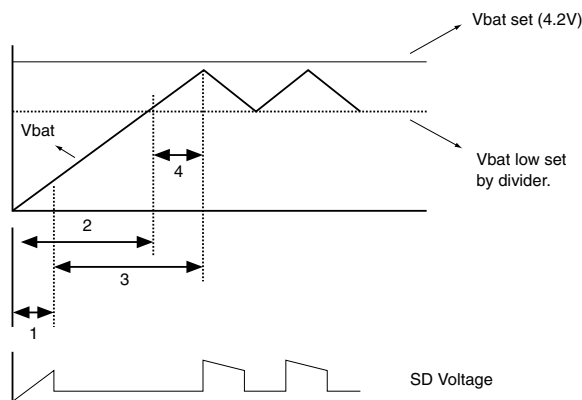

- 1 - SD not held low by active high D_{EOC} because D_{EOC} Comparator's inputs do not common-mode to ground. Divider holds SD low so part can start.
- 2 - SD held low by divider
- 3 - SD held low by active high D_{EOC}
- 4 - Divider voltage above SD threshold and D_{EOC} open
- 5 - Divider voltage drops below SD threshold and charging begins again.

Top-Off-Charger with Internal Reset - Application Circuit

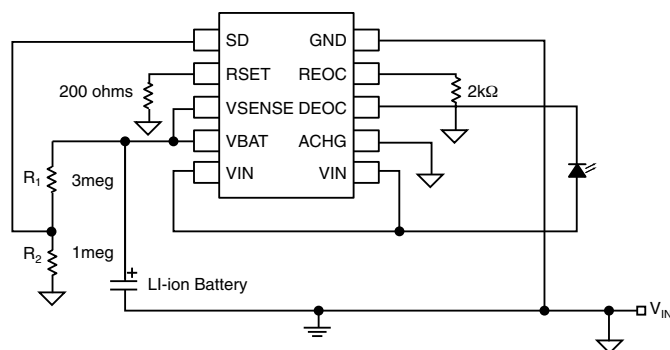

This circuit is similar to the auto top off charger circuit mentioned above except that the D_{EOC} pin is externally triggered to restart the charging cycle. It still uses the same resistor divider to set the minimum battery voltage before the lithium-ion needs to be recharged.

Auto-Shutdown Using Shutdown Pin

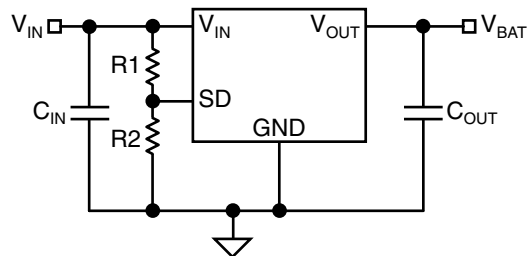

The shutdown pin on the MIC79110 can be used to automatically shutdown the battery charger when the input voltage rises above a safe operating voltage. To keep the part from heating up and entering thermal shutdown, we can connect the shutdown pin to V_{IN} using a resistor divider. Use the following equation to setup the maximum V_{IN} .

$$\frac{V_{IN(MAX)}}{V_{SD}} = \frac{R_1}{R_2} + 1$$

The MIC79110 can be connected to a wall wart with a rectified DC voltage and protected from over voltages at the input.

Package Information

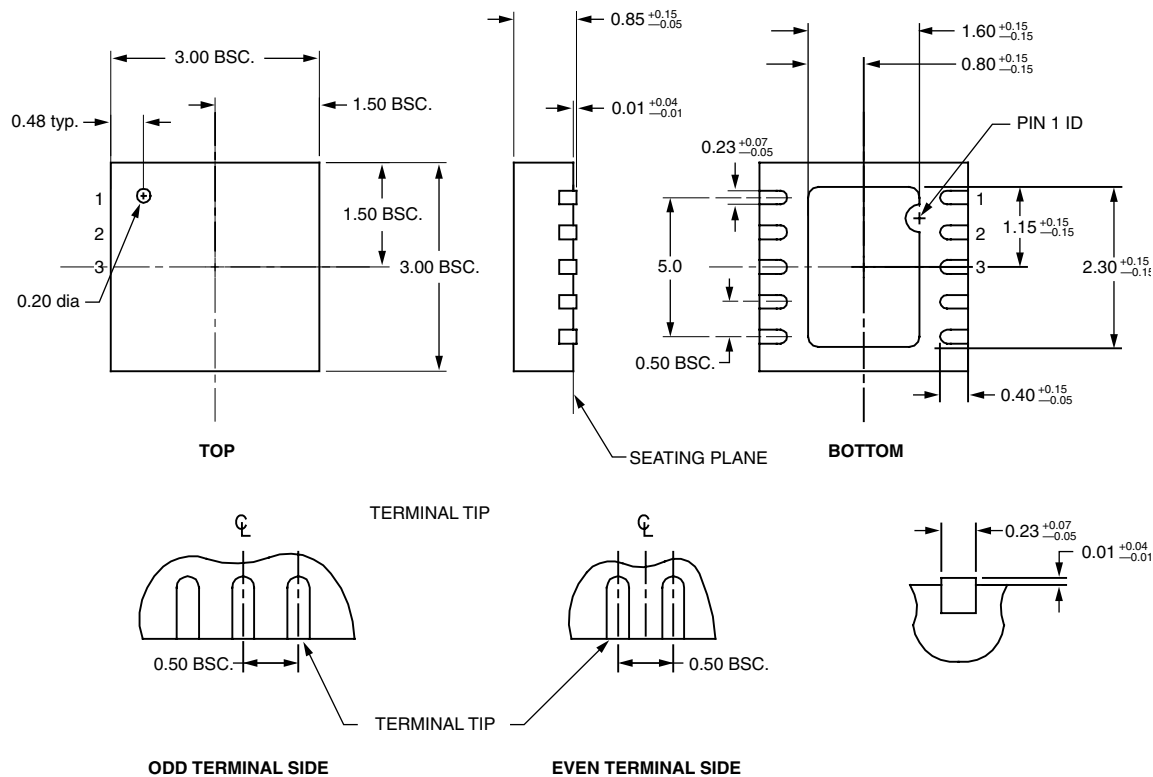

MICREL, INC. 1849 FORTUNE DRIVE SAN JOSE, CA 95131 USA

TEL + 1 (408) 944-0800 FAX + 1 (408) 474-1000 WEB <http://www.micrel.com>

The information furnished by Micrel in this data sheet is believed to be accurate and reliable. However, no responsibility is assumed by Micrel for its use. Micrel reserves the right to change circuitry and specifications at any time without notification to the customer.

Micrel Products are not designed or authorized for use as components in life support appliances, devices or systems where malfunction of a product can reasonably be expected to result in personal injury. Life support devices or systems are devices or systems that (a) are intended for surgical implant into the body or (b) support or sustain life, and whose failure to perform can be reasonably expected to result in a significant injury to the user. A Purchaser's use or sale of Micrel Products for use in life support appliances, devices or systems is at Purchaser's own risk and Purchaser agrees to fully indemnify Micrel for any damages resulting from such use or sale.

© 2004 Micrel, Incorporated.

Copyright Each Manufacturing Company.

All Datasheets cannot be modified without permission.

This datasheet has been download from :

www.AllDataSheet.com

100% Free DataSheet Search Site.

Free Download.

No Register.

Fast Search System.

www.AllDataSheet.com