



100MS

EMI SHIELD

DESCRIPTION

The 100MS is an epoxy encapsulated electromagnetic/ electrostatic interference (EMI) shield for use with circuits where sensitivity to EMI is critical. It was designed to attenuate EMI by converting electromagnetic field energy into heat that is absorbed by the shield and by shunting electrostatic fields to common. The 100MS may be used in applications to either confine or exclude EMI. Its cavity was designed for 28.45mm x 28.45mm x 7.24mm, 20-pin hybrid packages. The shields in the cover and base plate are in two separate halves to maintain the electrical isolation between the adjacent rows of pins of the module it encloses. Because of the spacing between the shield halves and epoxy flow holes, the 100MS provides a partial, but adequate low reluctance path for electromagnetic flux. The 100MS is well suited for use with isolation modules such as the Burr-Brown 3656, 722, and 724.

over the module so the tabs are aligned and fit into the slots in the base plate. Bend the four wide shield soldering tabs protruding from the cover to make contact with the bare metal on the base plate. Solder these four tabs to insure the integrity of their connection to the base plate.

The 100MS and the module it contains are mounted and secured to a printed circuit board (PCB) by soldering the two narrow PCB solder tabs to the appropriate common. The PCB solder tab closest to the input side of the module should be soldered to the input common. The other tab should be soldered to the output common. Figure 2 illustrates the assembly of the 100MS.

ASSEMBLY INSTRUCTIONS

Assemble the base plate to the module by pushing the pins of the module through the beveled holes in the base plate until the base plate and bottom of the module are in contact with each other. Place the cover

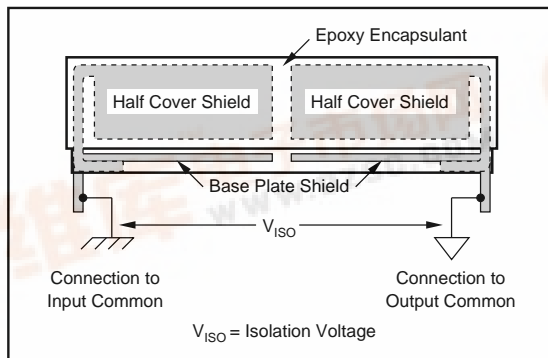

FIGURE 1. Cross-Sectional Side View of 100MS.

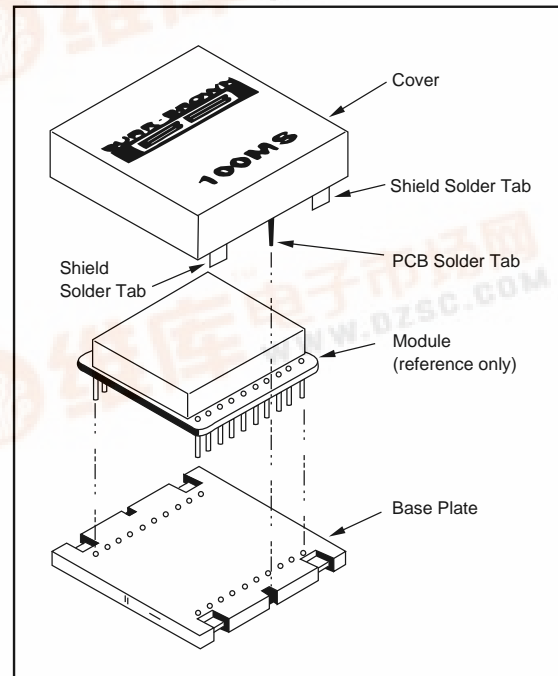

FIGURE 2. Assembly Diagram.



SPECIFICATIONS

ELECTRICAL

Specifications apply between solder tabs.

PARAMETER	CONDITIONS	100MS			UNITS
		MIN	TYP	MAX	
Isolation Voltage	10 Seconds	3500			VDC
Rated Continuous, DC		2000			Vrms
Rated Continuous, AC		8000			VDC
Test					VDC
Capacitance	120V, 60Hz		5		pF
Resistance			10^{10}		Ω
Leakage Current				0.23	μ A

NOTE: Temperature changes ($\Delta T/\Delta t$) greater than 1°C per minute below 0°C and long term storage above 100°C are not recommended.

PACKAGE INFORMATION⁽¹⁾

MODEL	PACKAGE	PACKAGE DRAWING NUMBER
100MS	EMI Shield	124

NOTE: (1) For detailed drawing and dimension table, please see end of data sheet, or Appendix D of Burr-Brown IC Data Book.

APPLICATIONS INFORMATION

MULTIPLE DEVICE ORIENTATION

A typical application for the 100MS is shown in Figure 3. Using multiple devices within 30mm of each other can cause them to interact by forming beat frequency interference outputs. The 100MS can reduce this interference by as much as a factor of 200:1 depending on the distance between the devices and their relative orientation.

Minimum EMI results when the gaps of both shields are paralleled as in Figure 3a.

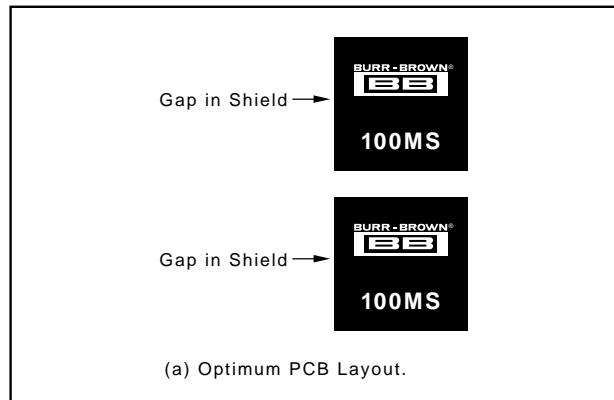

FIGURE 3a. Optimum PCB Layout. Orientation for minimum EMI.

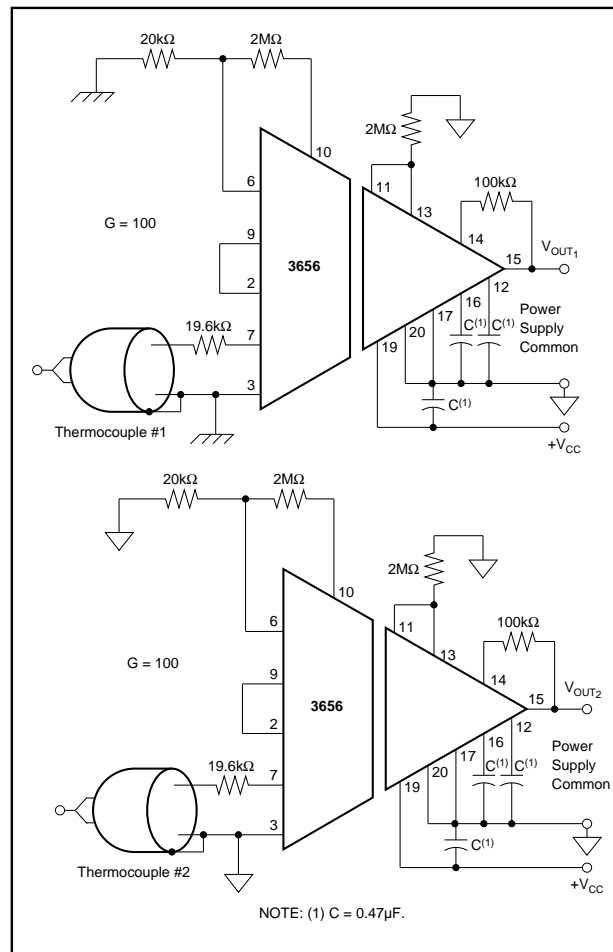

FIGURE 3b. Isolated Data Acquisition Input Circuitry. Orientation for Minimum EMI.

The information provided herein is believed to be reliable; however, BURR-BROWN assumes no responsibility for inaccuracies or omissions. BURR-BROWN assumes no responsibility for the use of this information, and all use of such information shall be entirely at the user's own risk. Prices and specifications are subject to change without notice. No patent rights or licenses to any of the circuits described herein are implied or granted to any third party. BURR-BROWN does not authorize or warrant any BURR-BROWN product for use in life support devices and/or systems.

PACKAGING INFORMATION

Orderable Device	Status ⁽¹⁾	Package Type	Package Drawing	Pins	Package Qty	Eco Plan ⁽²⁾	Lead/Ball Finish	MSL Peak Temp ⁽³⁾
0100MS	ACTIVE	PDIP	NSP	20	25	None	Call TI	Level-NA-NA-NA

⁽¹⁾ The marketing status values are defined as follows:

ACTIVE: Product device recommended for new designs.

LIFEBUY: TI has announced that the device will be discontinued, and a lifetime-buy period is in effect.

NRND: Not recommended for new designs. Device is in production to support existing customers, but TI does not recommend using this part in a new design.

PREVIEW: Device has been announced but is not in production. Samples may or may not be available.

OBsolete: TI has discontinued the production of the device.

⁽²⁾ Eco Plan - May not be currently available - please check <http://www.ti.com/productcontent> for the latest availability information and additional product content details.

None: Not yet available Lead (Pb-Free).

Pb-Free (RoHS): TI's terms "Lead-Free" or "Pb-Free" mean semiconductor products that are compatible with the current RoHS requirements for all 6 substances, including the requirement that lead not exceed 0.1% by weight in homogeneous materials. Where designed to be soldered at high temperatures, TI Pb-Free products are suitable for use in specified lead-free processes.

Green (RoHS & no Sb/Br): TI defines "Green" to mean "Pb-Free" and in addition, uses package materials that do not contain halogens, including bromine (Br) or antimony (Sb) above 0.1% of total product weight.

⁽³⁾ MSL, Peak Temp. -- The Moisture Sensitivity Level rating according to the JEDEC industry standard classifications, and peak solder temperature.

Important Information and Disclaimer: The information provided on this page represents TI's knowledge and belief as of the date that it is provided. TI bases its knowledge and belief on information provided by third parties, and makes no representation or warranty as to the accuracy of such information. Efforts are underway to better integrate information from third parties. TI has taken and continues to take reasonable steps to provide representative and accurate information but may not have conducted destructive testing or chemical analysis on incoming materials and chemicals. TI and TI suppliers consider certain information to be proprietary, and thus CAS numbers and other limited information may not be available for release.

In no event shall TI's liability arising out of such information exceed the total purchase price of the TI part(s) at issue in this document sold by TI to Customer on an annual basis.

IMPORTANT NOTICE

Texas Instruments Incorporated and its subsidiaries (TI) reserve the right to make corrections, modifications, enhancements, improvements, and other changes to its products and services at any time and to discontinue any product or service without notice. Customers should obtain the latest relevant information before placing orders and should verify that such information is current and complete. All products are sold subject to TI's terms and conditions of sale supplied at the time of order acknowledgment.

TI warrants performance of its hardware products to the specifications applicable at the time of sale in accordance with TI's standard warranty. Testing and other quality control techniques are used to the extent TI deems necessary to support this warranty. Except where mandated by government requirements, testing of all parameters of each product is not necessarily performed.

TI assumes no liability for applications assistance or customer product design. Customers are responsible for their products and applications using TI components. To minimize the risks associated with customer products and applications, customers should provide adequate design and operating safeguards.

TI does not warrant or represent that any license, either express or implied, is granted under any TI patent right, copyright, mask work right, or other TI intellectual property right relating to any combination, machine, or process in which TI products or services are used. Information published by TI regarding third-party products or services does not constitute a license from TI to use such products or services or a warranty or endorsement thereof. Use of such information may require a license from a third party under the patents or other intellectual property of the third party, or a license from TI under the patents or other intellectual property of TI.

Reproduction of information in TI data books or data sheets is permissible only if reproduction is without alteration and is accompanied by all associated warranties, conditions, limitations, and notices. Reproduction of this information with alteration is an unfair and deceptive business practice. TI is not responsible or liable for such altered documentation.

Resale of TI products or services with statements different from or beyond the parameters stated by TI for that product or service voids all express and any implied warranties for the associated TI product or service and is an unfair and deceptive business practice. TI is not responsible or liable for any such statements.

Following are URLs where you can obtain information on other Texas Instruments products and application solutions:

Products		Applications	
Amplifiers	amplifier.ti.com	Audio	www.ti.com/audio
Data Converters	dataconverter.ti.com	Automotive	www.ti.com/automotive
DSP	dsp.ti.com	Broadband	www.ti.com/broadband
Interface	interface.ti.com	Digital Control	www.ti.com/digitalcontrol
Logic	logic.ti.com	Military	www.ti.com/military
Power Mgmt	power.ti.com	Optical Networking	www.ti.com/opticalnetwork
Microcontrollers	microcontroller.ti.com	Security	www.ti.com/security
		Telephony	www.ti.com/telephony
		Video & Imaging	www.ti.com/video
		Wireless	www.ti.com/wireless

Mailing Address: Texas Instruments
Post Office Box 655303 Dallas, Texas 75265