

PRELIMINARY DATA SHEET

**CEL**

**NEC's  
4-PIN ULTRA SMALL FLAT-LEAD  
SUPER LOW OUTPUT CAPACITANCE  
1-ch OPTICAL COUPLED MOS FET**

**PS7801C-1A**

**FEATURES**

- **ULTRA SMALL FLAT-LEAD PACKAGE:**  
4.2 (L) × 2.5 (W) × 1.85 (H) mm
- **SUPER LOW OUTPUT CAPACITANCE:**  
 $C_{out} = 0.5 \text{ pF TYP.}$
- **LOW C × R:**  
 $C \times R = 6.5 \text{ pF} \cdot \Omega$
- **1 CHANNEL TYPE:**  
1 a output
- **DESIGN FOR AC/DC SWITCHING LINE CHANGER**
- **LOW OFFSET VOLTAGE**
- **ORDERING NUMBER OF TAPING PRODUCT:**  
PS7801C-1A-F3, F4: 3 500 pcs/reel

**DESCRIPTION**

NEC's PS7801C-1A is a low output capacitance solid state relay containing a GaAs LED on the light emitting side (input side) and MOS FETs on the output side.

An ultra small flat-lead package has been provided which realizes a reduction in mounting area of about 50% compared with the PS72xx series.

It is suitable for high-frequency signal control, due to its low C × R, super low output capacitance, and low off-state leakage current.

**APPLICATION**

- Measurement Equipment



# PS7801C-1A

## PACKAGE DIMENSIONS (UNIT: mm)

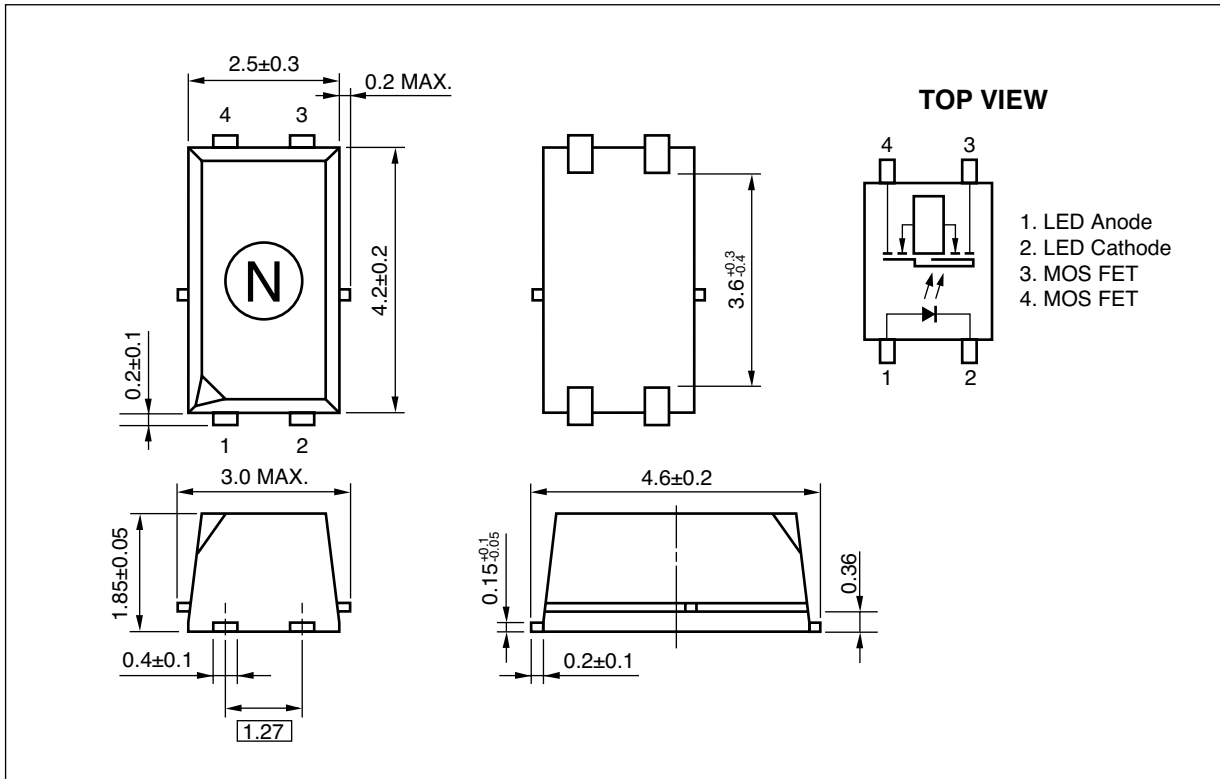

## MARKING EXAMPLE

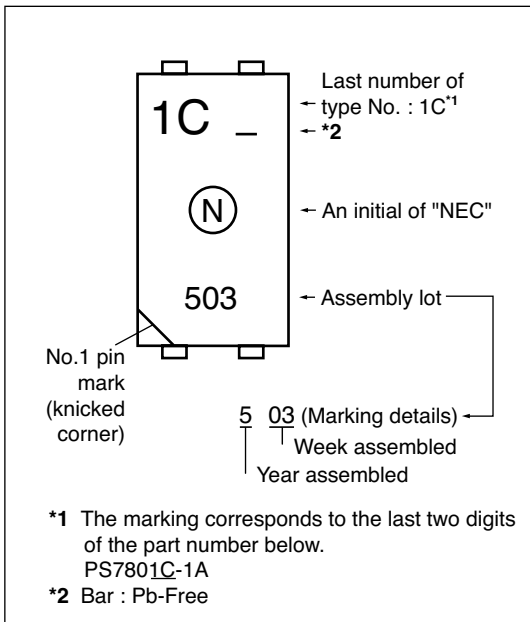

**ORDERING INFORMATION**

PART NUMBER	ORDER NUMBER	SOLDER PLATING SPECIFICATION	PACKING STYLE
PS7801C-1A-F3	PS7801C-1A-F3-A	Pb-Free	Embossed Tape 3 500 pcs/reel
PS7801C-1A-F4	PS7801C-1A-F4-A		

**ABSOLUTE MAXIMUM RATINGS** ( $T_A = 25^\circ\text{C}$ , unless otherwise Specified)

PARAMETER		SYMBOL	RATINGS	UNIT
<b>Diode</b>	Forward Current (DC)	$I_F$	50	mA
	Reverse Voltage	$V_R$	5.0	V
	Power Dissipation	$P_D$	50	mW
	Peak Forward Current <sup>*1</sup>	$I_{FP}$	1	A
<b>MOS FET</b>	Break Down Voltage	$V_L$	30	V
	Continuous Load Current	$I_L$	80	mA
	Pulse Load Current <sup>*2</sup> (AC/DC Connection)	$I_{LP}$	160	mA
	Power Dissipation	$P_D$	250	mW
Isolation Voltage <sup>*3</sup>		$BV$	500	Vr.m.s.
Total Power Dissipation		$P_T$	300	mW
Operating Ambient Temperature		$T_A$	-40 to +85	$^\circ\text{C}$
Storage Temperature		$T_{stg}$	-40 to +100	$^\circ\text{C}$

\*1  $PW = 100 \mu\text{s}$ , Duty Cycle = 1%

\*2  $PW = 100 \text{ms}$ , 1 shot

\*3 AC voltage for 1 minute at  $T_A = 25^\circ\text{C}$ , RH = 60% between input and output.  
Pins 1-2 shorted together, 3-4 shorted together.

**RECOMMENDED OPERATING CONDITIONS** ( $T_A = 25^\circ\text{C}$ )

PARAMETER	SYMBOL	MIN.	TYP.	MAX.	UNIT
LED Operating Current	$I_F$	2	5	20	mA
LED Off Voltage	$V_F$	0		0.5	V

# PS7801C-1A

## ELECTRICAL CHARACTERISTICS (TA = 25 85°C)

PARAMETER		SYMBOL	CONDITIONS	MIN.	TYP.	MAX.	UNIT
Diode	Forward Voltage	$V_F$	$I_F = 5 \text{ mA}$		1.1	1.4	V
	Reverse Current	$I_R$	$V_R = 5 \text{ V}$			5.0	$\mu\text{A}$
MOS FET	Off-state Leakage Current	$I_{\text{Leak}}$	$V_D = 30 \text{ V}$		0.1	1.0	nA
	Output Capacitance	$C_{\text{out}}$	$V_D = 0 \text{ V}, f = 1 \text{ MHz}$		0.5	0.7	pF
Coupled	LED On-state Current	$I_{\text{Fon}}$	$I_L = 80 \text{ mA}$			2.0	mA
	On-state Resistance	$R_{\text{on}}$	$I_F = 5 \text{ mA}, I_L = 80 \text{ mA}$		13	17	$\Omega$
	Turn-on Time* <sup>1,2</sup>	$t_{\text{on}}$	$I_F = 5 \text{ mA}, V_O = 5 \text{ V}, R_L = 500 \Omega,$ $PW \geq 10 \text{ ms}$		0.03	0.5	ms
	Turn-off Time* <sup>1,2</sup>	$t_{\text{off}}$			0.1	0.5	
	Isolation Resistance	$R_{\text{I-O}}$	$V_{\text{I-O}} = 0.5 \text{ kV}_{\text{DC}}$		$10^9$		$\Omega$
	Isolation Capacitance	$C_{\text{I-O}}$	$V = 0 \text{ V}, f = 1 \text{ MHz}$			0.3	pF

### \*1 Test Circuit for Switching Time

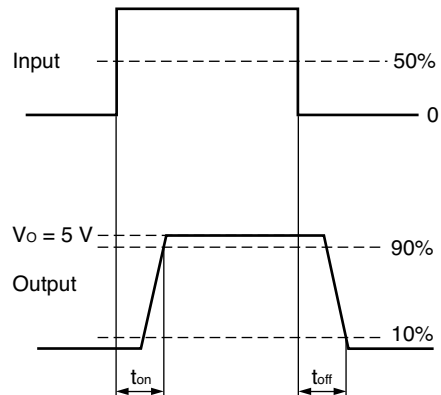
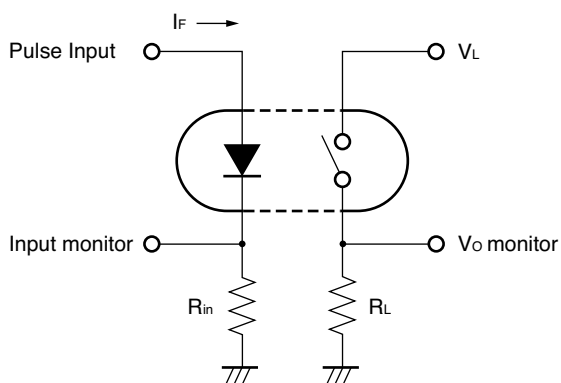

### \*2 The turn-on time and turn-off time are specified as input-pulse width $\geq 10 \text{ ms}$ .

Be aware that when the device operates with an input-pulse width less than 10 ms, the turn-on time and turn-off time will increase.

## NOTES ON HANDLING

### Recommended soldering conditions

#### (1) Infrared reflow soldering

- Peak reflow temperature 260°C or below (package surface temperature)
- Time of peak reflow temperature 10 seconds or less
- Time of temperature higher than 220°C 60 seconds or less
- Time to preheat temperature from 120 to 180°C 120±30 s
- Number of reflows Three
- Flux Rosin flux containing small amount of chlorine (The flux with a maximum chlorine content of 0.2 Wt% is recommended.)

Recommended Temperature Profile of Infrared Reflow

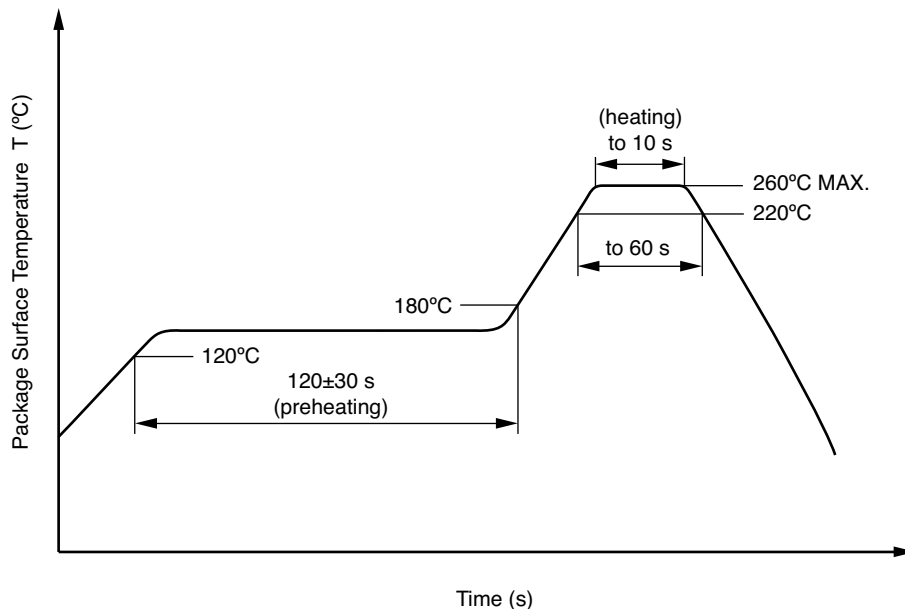

#### (2) Wave soldering

- Temperature 260°C or below (molten solder temperature)
- Time 10 seconds or less
- Preheating conditions 120°C or below (package surface temperature)
- Number of times One
- Flux Rosin flux containing small amount of chlorine (The flux with a maximum chlorine content of 0.2 Wt% is recommended.)

#### (3) Cautions

- Fluxes
  - Avoid removing the residual flux with freon-based and chlorine-based cleaning solvent.

#### Life Support Applications

These NEC products are not intended for use in life support devices, appliances, or systems where the malfunction of these products can reasonably be expected to result in personal injury. The customers of CEL using or selling these products for use in such applications do so at their own risk and agree to fully indemnify CEL for all damages resulting from such improper use or sale.