

**FAIRCHILD**  
SEMICONDUCTOR®

# LOW INPUT CURRENT HIGH GAIN SPLIT DARLINGTON OPTOCOUPLEDERS

**SINGLE CHANNEL:**  
**DUAL CHANNEL:**

**HCPL-0700**  
**HCPL-0730**

**HCPL-0701**  
**HCPL-0731**

## DESCRIPTION

The HCPL-0700, HCPL-0701, HCPL-0730 and HCPL-0731 optocouplers consist of an AlGaAs LED optically coupled to a high gain split darlington photodetector housed in a compact 8-pin small outline package. The HCPL-0730 and HCPL-0731 devices have two channels per package for optimum mounting density.

The split darlington configuration separating the input photodiode and the first stage gain from the output transistor permits lower output saturation voltage and higher speed operation than possible with conventional darlington phototransistor optocoupler.

The combination of a very low input current of 0.5 mA and a high current transfer ratio of 2000% makes this family particularly useful for input interface to MOS, CMOS, LSTTL and EIA RS232C, while output compatibility is ensured to CMOS as well as high fan-out TTL requirements.

## FEATURES

- Low input current – 0.5 mA
- Superior CTR – 2000%
- Superior CMR – 10 kV/μs
- CTR guaranteed 0-70°C
- U.L. Recognized (file# E90700)
- VDE 0884 recognized (file# 136616)  
– approval pending for HCPL-0730/0731
- BSI recognized (file# 8661, 8662)  
– HCPL-0700/0701 only

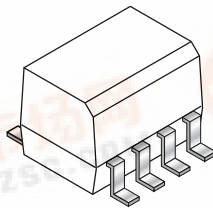

## APPLICATIONS

- Digital logic ground isolation
- Telephone ring detector
- EIA-RS-232C line receiver
- High common mode noise line receiver
- μP bus isolation
- Current loop receiver

## TRUTH TABLE

LED	V <sub>O</sub>
ON	LOW
OFF	HIGH

## PACKAGE DIMENSIONS

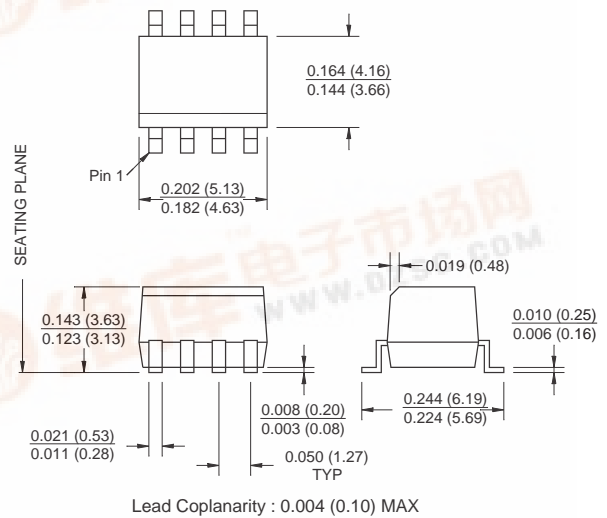

## NOTE

All dimensions are in inches (millimeters)

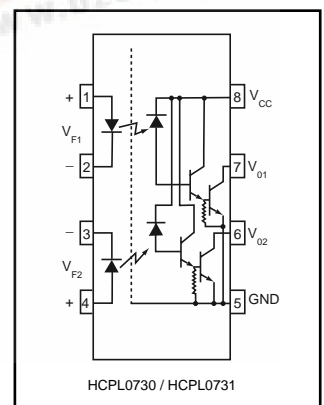
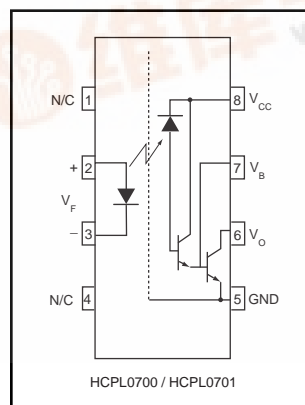

**LOW INPUT CURRENT  
HIGH GAIN SPLIT  
DARLINGTON OPTOCOUPLEDERS**

<b>SINGLE CHANNEL:</b>	<b>HCPL-0700</b>	<b>HCPL-0701</b>
<b>DUAL CHANNEL:</b>	<b>HCPL-0730</b>	<b>HCPL-0731</b>

<b>ABSOLUTE MAXIMUM RATINGS</b> ( $T_A = 25^\circ\text{C}$ unless otherwise specified)				
Parameter	Symbol	Value	Units	
Storage Temperature	$T_{\text{STG}}$	-40 to +125	$^\circ\text{C}$	
Operating Temperature	$T_{\text{OPR}}$	-40 to +85	$^\circ\text{C}$	
Reflow Temperature Profile (Refer to fig. 11)				
<b>EMITTER</b>				
DC/Average Forward Input Current	$I_F$ (avg)	20	mA	
Peak Forward Input Current (50% duty cycle, 1 ms P.W.)	$I_F$ (pk)	40	mA	
Peak Transient Input Current - ( $\leq 1 \mu\text{s}$ P.W., 300 pps)	$I_F$ (trans)	1.0	A	
Reverse Input Voltage	$V_R$	5	V	
Input Power Dissipation	$P_D$	35	mW	
<b>DETECTOR</b>				
Average Output Current (Pin 6)	$I_O$ (avg)	60	mA	
Emitter-Base Reverse Voltage	HCPL-0700/HCPL-0701	$V_{\text{EBR}}$	0.5	V
Supply Voltage, Output Voltage	HCPL-0700/HCPL-0730	$V_{\text{CC}}, V_O$	-0.5 to 7	V
	HCPL-0701/HCPL-0731		-0.5 to 18	
Output power dissipation	$P_D$	100	mW	

<b>ELECTRICAL CHARACTERISTICS</b> ( $T_A = 0$ to $70^\circ\text{C}$ Unless otherwise specified)								
<b>INDIVIDUAL COMPONENT CHARACTERISTICS</b>								
Parameter	Test Conditions		Symbol	Device	Min	Typ**	Max	Unit
<b>EMITTER</b> Input Forward Voltage	$I_F = 1.6\text{mA}$	$T_A = 25^\circ\text{C}$	$V_F$	HCLP-0700/01	1.0	1.25	1.7	V
				HCLP-0730/31		1.35		
				All		1.75		
Input Reverse Breakdown Voltage	$(T_A = 25^\circ\text{C}, I_R = 10 \mu\text{A})$		$BV_R$	All	5.0			
<b>DETECTOR</b> Logic high output current	$(I_F = 0 \text{ mA}, V_O = V_{\text{CC}} = 18 \text{ V})$		$I_{\text{OH}}$	HCPL-0701/31		0.01	100	$\mu\text{A}$
	$(I_F = 0 \text{ mA}, V_O = V_{\text{CC}} = 7 \text{ V})$			HCPL-0700/30		0.01	250	
Logic Low Supply Current	$I_F = 1.6 \text{ mA}, V_O = \text{Open}, V_{\text{CC}} = 18 \text{ V}$		$I_{\text{CCL}}$	HCPL-0700/01		0.4	1.5	mA
	$I_{F1} = I_{F2} = 1.6 \text{ mA}$	$V_{\text{CC}} = 7 \text{ V}$		HCPL-0730		0.8	3	
		$V_{O1} = V_{O2} = \text{Open}, V_{\text{CC}} = 18 \text{ V}$		HCPL-0731		1		
Logic High Supply Current	$I_F = 0 \text{ mA}, V_O = \text{Open}, V_{\text{CC}} = 18 \text{ V}$		$I_{\text{CCH}}$	HCPL-0700/01			10	$\mu\text{A}$
	$I_{F1} = I_{F2} = 0,$	$V_{\text{CC}} = 7 \text{ V}$		HCPL-0730		0.001	20	
		$V_{O1} = V_{O2} = \text{Open}, V_{\text{CC}} = 18 \text{ V}$		HCPL-0731		0.01		

**LOW INPUT CURRENT  
HIGH GAIN SPLIT  
DARLINGTON OPTOCOUPLEDERS**

**SINGLE CHANNEL: HCPL-0700 HCPL-0701**  
**DUAL CHANNEL: HCPL-0730 HCPL-0731**

<b>TRANSFER CHARACTERISTICS</b> ( $T_A = 0$ to $70^\circ\text{C}$ Unless otherwise specified)							
Parameter	Test Conditions	Symbol	Device	Min	Typ**	Max	Unit
<b>COUPLED</b>  Current transfer ratio (Notes 1,2)	( $I_F = 0.5\text{ mA}$ , $V_O = 0.4\text{ V}$ , $V_{CC} = 4.5\text{ V}$ )	CTR	HCPL-0701/31	400		5000	%
			HCPL-0700	300		2600	
	$I_F = 1.6\text{ mA}$ , $V_O = 0.4\text{ V}$ , $V_{CC} = 4.5\text{ V}$		HCPL-0701	500		2600	
			HCPL-0730	300		5000	
			HCPL-0731	500		5000	
Logic low output voltage output voltage	( $I_F = 0.5\text{ mA}$ , $I_O = 2\text{ mA}$ , $V_{CC} = 4.5\text{ V}$ )	V <sub>OL</sub>	HCPL-0701 HCPL-0731			0.4	V
	( $I_F = 1.6\text{ mA}$ , $I_O = 8\text{ mA}$ , $V_{CC} = 4.5\text{ V}$ )					0.4	
	( $I_F = 5\text{ mA}$ , $I_O = 15\text{ mA}$ , $V_{CC} = 4.5\text{ V}$ )					0.4	
	( $I_F = 12\text{ mA}$ , $I_O = 24\text{ mA}$ , $V_{CC} = 4.5\text{ V}$ )					0.4	
	( $I_F = 1.6\text{ mA}$ , $I_O = 4.8\text{ mA}$ , $V_{CC} = 4.5\text{ V}$ )		HCPL-0700/0730			0.4	

<b>ISOLATION CHARACTERISTICS</b> ( $T_A = 0$ to $70^\circ\text{C}$ Unless otherwise specified)						
Characteristics	Test Conditions	Symbol	Min	Typ**	Max	Unit
Input-output insulation leakage current	(Relative humidity = 45%) ( $T_A = 25^\circ\text{C}$ , $t = 5\text{ s}$ ) ( $V_{I-O} = 3000\text{ VDC}$ ) (Note 4)	$I_{I-O}$			1.0	$\mu\text{A}$
Withstand insulation test voltage	( $R_H \leq 50\%$ , $T_A = 25^\circ\text{C}$ ) (Note 4, 5) ( $t = 1\text{ min.}$ )	$V_{ISO}$	2500			$V_{RMS}$
Resistance (input to output)	(Note 4) ( $V_{I-O} = 500\text{ VDC}$ )	$R_{I-O}$		$10^{12}$		$\Omega$

\*\* All typicals at  $T_A = 25^\circ\text{C}$

**LOW INPUT CURRENT  
HIGH GAIN SPLIT  
DARLINGTON OPTOCOUPLEDERS**

**SINGLE CHANNEL:  
DUAL CHANNEL:**

**HCPL-0700  
HCPL-0730**

**HCPL-0701  
HCPL-0731**

SWITCHING CHARACTERISTICS ( $T_A = 0$ to $70^\circ\text{C}$ unless otherwise specified., $V_{CC} = 5\text{ V}$ )								
Parameter	Test Conditions	Symbol	Device	Min	Typ**	Max	Unit	
Propagation delay time to logic low (Note 2) (Fig. 14)	$(R_L = 4.7\text{ k}\Omega, I_F = 0.5\text{ mA})$ $T_A = 25^\circ\text{C}$	$T_{PHL}$	HCPL-0701			30	$\mu\text{s}$	
			HCPL-0731			120		
			HCPL-0701			3		25
			HCPL-0731			5		100
	$(R_L = 270\ \Omega, I_F = 12\text{ mA})$ $T_A = 25^\circ\text{C}$		HCPL-0701	2				
			HCPL-0731	3				
			HCPL-0701	0.3	1			
			HCPL-0731	0.4	2			
	$(R_L = 2.2\text{ k}\Omega, I_F = 1.6\text{ mA})$ $T_A = 25^\circ\text{C}$		HCPL-0700	15				
			HCPL-0730/0731	25				
			HCPL-0700	1	10			
			HCPL-0730/0731	2	20			
Propagation delay time to logic high (Note 2) (Fig. 14)	$(R_L = 4.7\text{ k}\Omega, I_F = 0.5\text{ mA})$ $T_A = 25^\circ\text{C}$	$T_{PLH}$	HCPL-0701/31			90	$\mu\text{s}$	
			HCPL-0701/31			12		60
	$(R_L = 270\ \Omega, I_F = 12\text{ mA})$ $T_A = 25^\circ\text{C}$		HCPL-0701	10				
			HCPL-0731	15				
	$(R_L = 2.2\text{ k}\Omega, I_F = 1.6\text{ mA})$ $T_A = 25^\circ\text{C}$		HCPL-0701	1.6	7			
			HCPL-0731	1.6	10			
	$(R_L = 2.2\text{ k}\Omega, I_F = 1.6\text{ mA})$ $T_A = 25^\circ\text{C}$		HCPL-0700/30/31	50				
			HCPL-0700/30/31	7	35			
Common mode transient immunity at logic high	$(I_F = 0\text{ mA},  V_{CM}  = 10\text{ V}_{P-P})$ $T_A = 25^\circ\text{C}$ ( $R_L = 2.2\text{ k}\Omega$ ) (Note 3) (Fig. 15)	$ CM_H $	ALL	1,000	10,000		$\text{V}/\mu\text{s}$	
Common mode transient immunity at logic low	$(I_F = 1.6\text{ mA},  V_{CM}  = 10\text{ V}_{P-P})$ $R_L = 2.2\text{ k}\Omega$ $T_A = 25^\circ\text{C}$ (Note 3) (Fig. 15)	$ CM_L $	ALL	1,000	10,000		$\text{V}/\mu\text{s}$	

**NOTES**

- Current Transfer Ratio is defined as a ratio of output collector current,  $I_O$ , to the forward LED input current,  $I_F$  times 100%.
- Pin 7 open. Use of a resistor between pins 5 and 7 will decrease gain and delay time.
- Common mode transient immunity in logic high level is the maximum tolerable (positive)  $dV_{CM}/dt$  on the leading edge of the common mode pulse signal,  $V_{CM}$ , to assure that the output will remain in a logic high state (i.e.,  $V_O > 2.0\text{ V}$ ). Common mode transient immunity in logic low level is the maximum tolerable (negative)  $dV_{CM}/dt$  on the trailing edge of the common mode pulse signal,  $V_{CM}$ , to assure that the output will remain in a logic low state (i.e.,  $V_O < 0.8\text{ V}$ ).
- Device is considered a two terminal device: Pins 1, 2, 3 and 4 are shorted together and Pins 5, 6, 7 and 8 are shorted together.
- 2500 VAC RMS for 1 minute duration is equivalent to 3000 VAC RMS for 1 second duration.

\*\* All typicals at  $T_A = 25^\circ\text{C}$

# LOW INPUT CURRENT HIGH GAIN SPLIT DARLINGTON OPTOCOUPLEDERS

**SINGLE CHANNEL:  
DUAL CHANNEL:**

**HCPL-0700  
HCPL-0730**

**HCPL-0701  
HCPL-0731**

## TYPICAL PERFORMANCE CURVES

**Fig. 1 Propagation Delay vs. Temperature  
(HCPL-0700, HCPL-0701)**

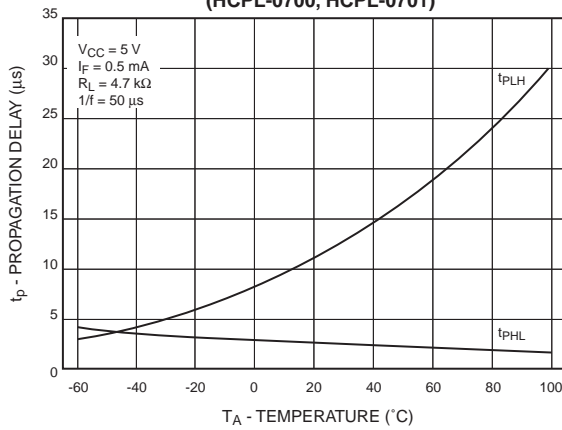

**Fig. 2 Propagation Delay vs. Temperature  
(HCPL-0700, HCPL-0701)**

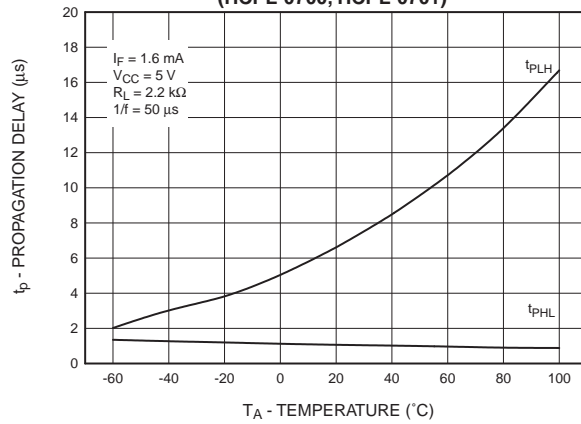

**Fig. 3 Propagation Delay vs. Temperature  
(HCPL-0700, HCPL-0701)**

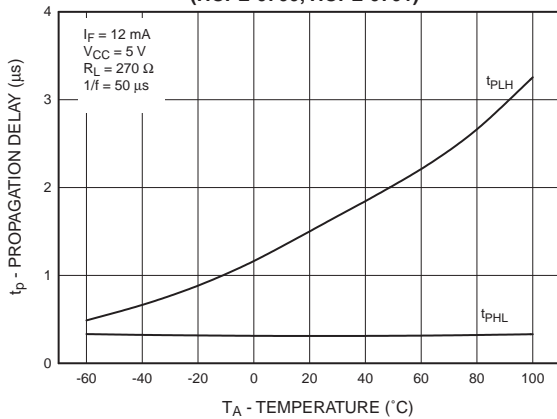

**Fig. 4 Logic High Output Current vs. Temperature  
(HCPL-0700, HCPL-0701)**

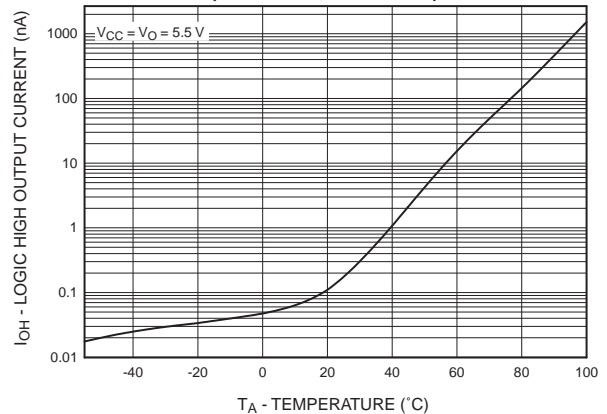

**Fig. 5 Propagation Delay vs. Input Forward Current  
(HCPL-0730, HCPL-0731)**

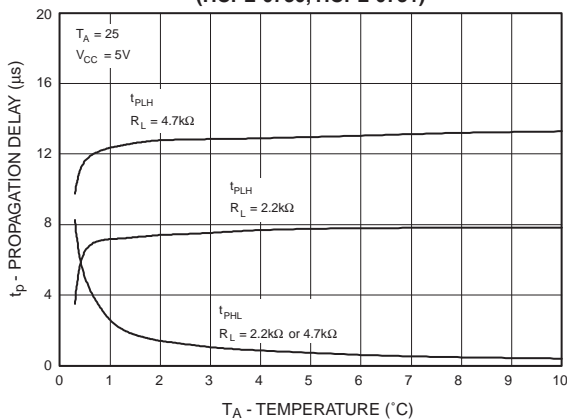

**Fig. 6 Output Current vs. Input Forward Current  
(HCPL-0700, HCPL-0701)**

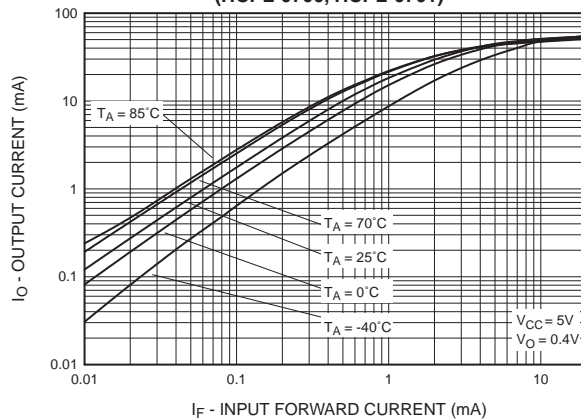

**SINGLE CHANNEL:  
DUAL CHANNEL:**

**HCPL-0700  
HCPL-0730**

**HCPL-0701  
HCPL-0731**

**TYPICAL PERFORMANCE CURVES**

**Fig. 7 Input Forward Current vs. Forward Voltage  
(HCPL-0700, HCPL-0701)**

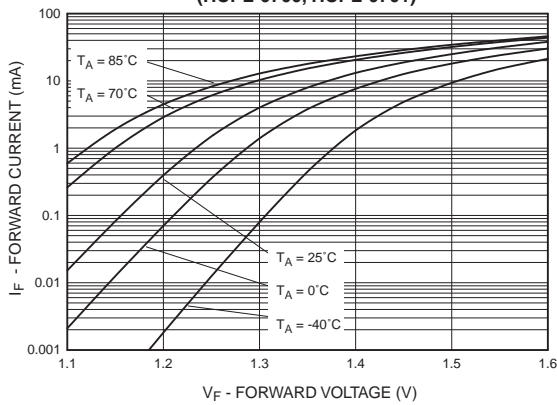

**Fig. 8 Input Forward Current vs. Forward Voltage  
(HCPL-0730, HCPL-0731)**

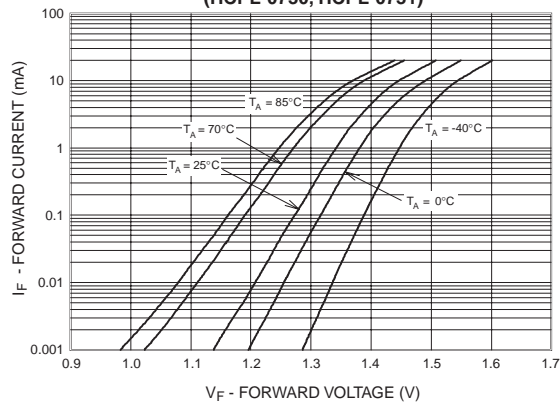

**Fig. 9 Logic Low Supply Current vs. Input Forward Current  
(HCPL-0700, HCPL-0701)**

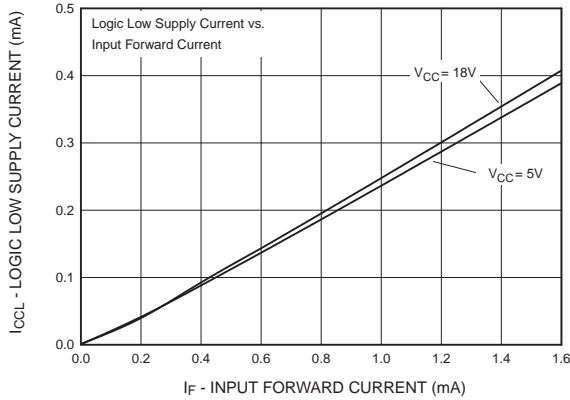

**Fig. 10 Supply Current vs. Input Forward Current  
(HCPL-0730, HCPL-0731)**

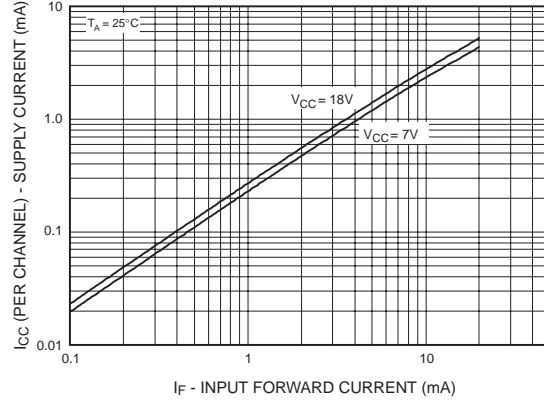

**Fig. 11 DC Transfer Characteristics  
(HCPL-0700, HCPL-0701)**

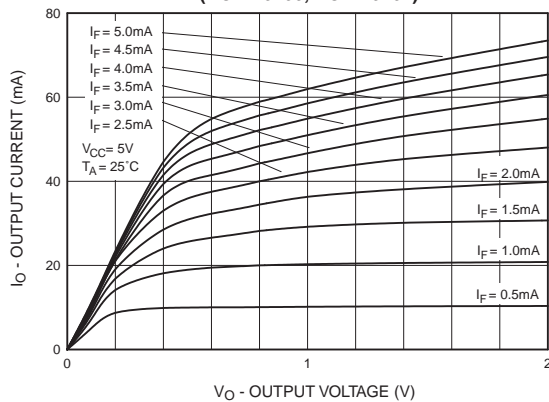

**Fig. 12 DC Transfer Characteristics  
(HCPL-0730, HCPL-0731)**

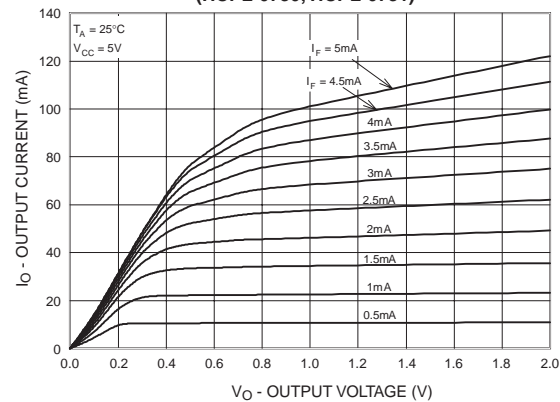

**SINGLE CHANNEL:  
DUAL CHANNEL:**

**HCPL-0700  
HCPL-0730**

**HCPL-0701  
HCPL-0731**

**TYPICAL PERFORMANCE CURVES**

**Fig. 13 Current Transfer Ratio vs. Input Forward Current  
(HCPL-0700, HCPL-0701)**

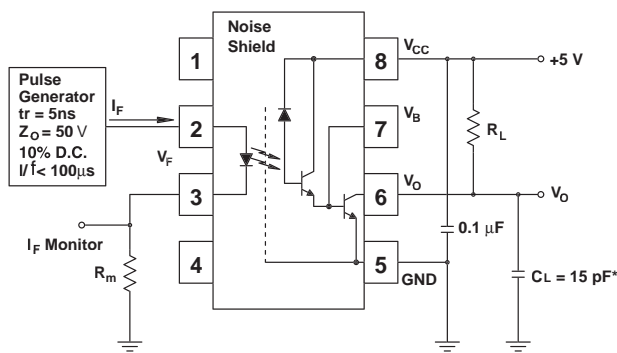
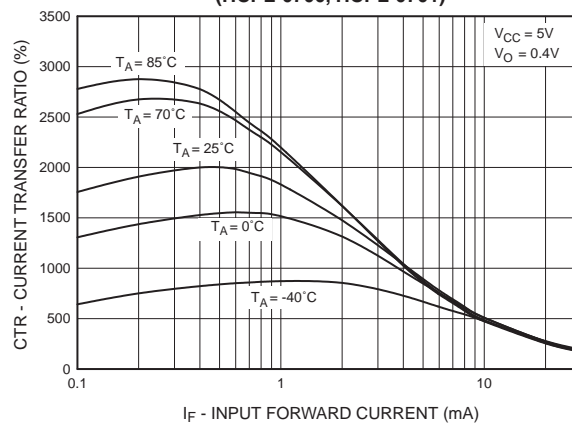

Test Circuit for HCPL-0700 and HCPL-0701

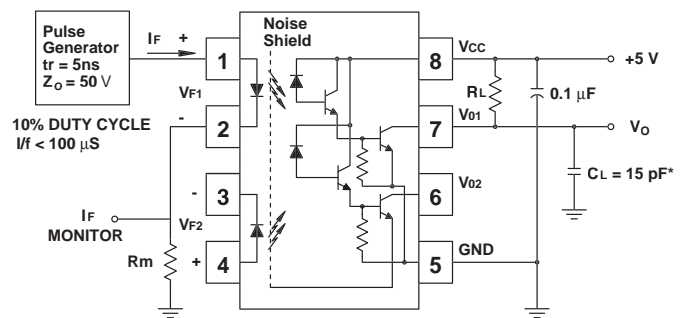

Test Circuit for HCPL-0730 and HCPL-0731

\*Includes probe and fixture capacitance

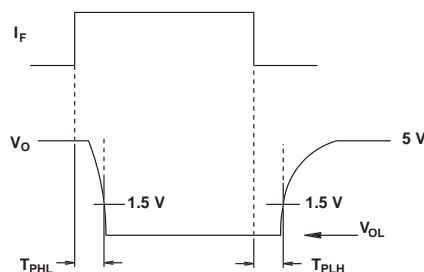

**Fig. 14 Switching Time Test Circuit**

# LOW INPUT CURRENT HIGH GAIN SPLIT DARLINGTON OPTOCOUPLERS

**SINGLE CHANNEL:  
DUAL CHANNEL:**

**HCPL-0700  
HCPL-0730**

**HCPL-0701  
HCPL-0731**

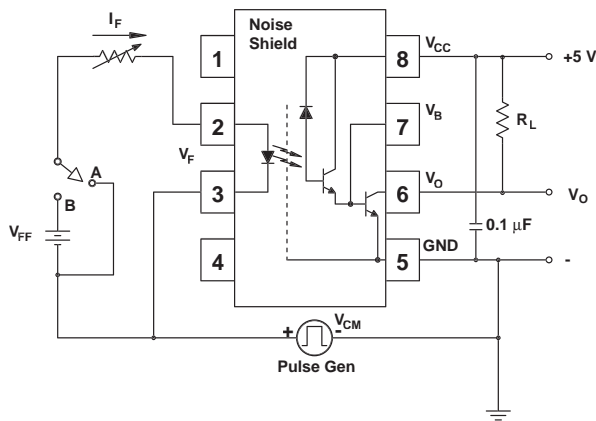

Test Circuit for HCPL-0700 and HCPL-0701

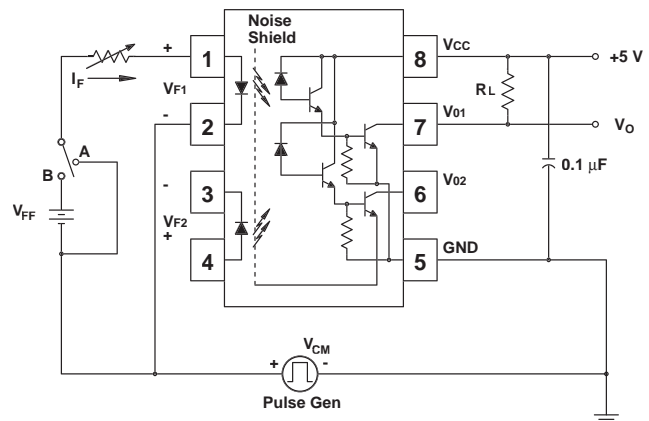

Test Circuit for HCPL-0730 and HCPL-0731

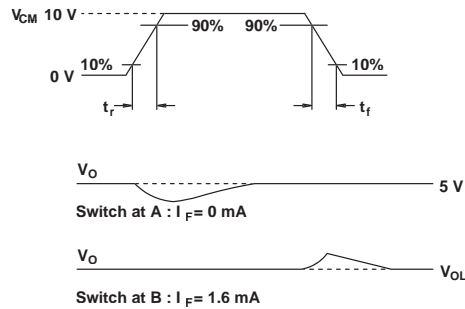

Fig. 15 Common Mode Immunity Test Circuit



**LOW INPUT CURRENT  
HIGH GAIN SPLIT  
DARLINGTON OPTOCOUPLEDERS**

**SINGLE CHANNEL:  
DUAL CHANNEL:**

**HCPL-0700  
HCPL-0730**

**HCPL-0701  
HCPL-0731**

**8-Pin Small Outline**

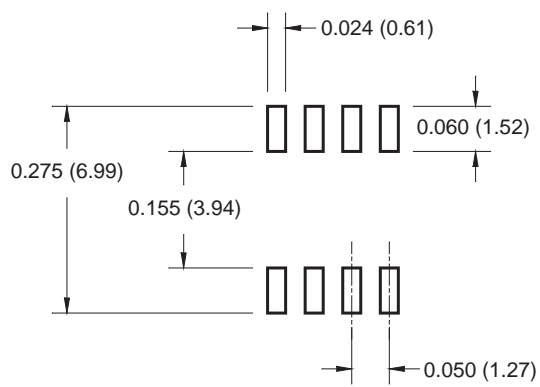

<b>SINGLE CHANNEL:</b>	<b>HCPL-0700</b>	<b>HCPL-0701</b>
<b>DUAL CHANNEL:</b>	<b>HCPL-0730</b>	<b>HCPL-0731</b>

**ORDERING INFORMATION**

Option	Order Entry Identifier	Description
V	V	VDE 0884
R1	R1	Tape and reel (500 units per reel)
R1V	R1V	VDE 0884, Tape and reel (500 units per reel)
R2	R2	Tape and reel (2500 units per reel)
R2V	R2V	VDE 0884, Tape and reel (2500 units per reel)

**MARKING INFORMATION**

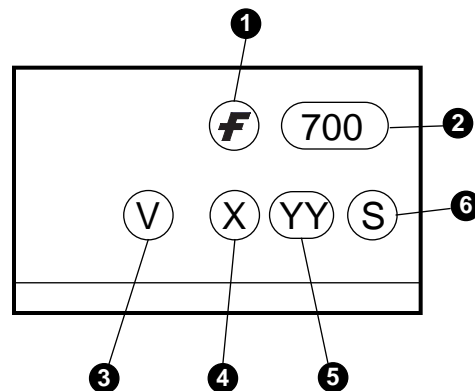

Definitions	
1	Fairchild logo
2	Device number
3	VDE mark (Note: Only appears on parts ordered with VDE option – See order entry table)
4	One digit year code, e.g., '3'
5	Two digit work week ranging from '01' to '53'
6	Assembly package code

**SINGLE CHANNEL:  
DUAL CHANNEL:**

**HCPL-0700  
HCPL-0730**

**HCPL-0701  
HCPL-0731**

**Carrier Tape Specifications**

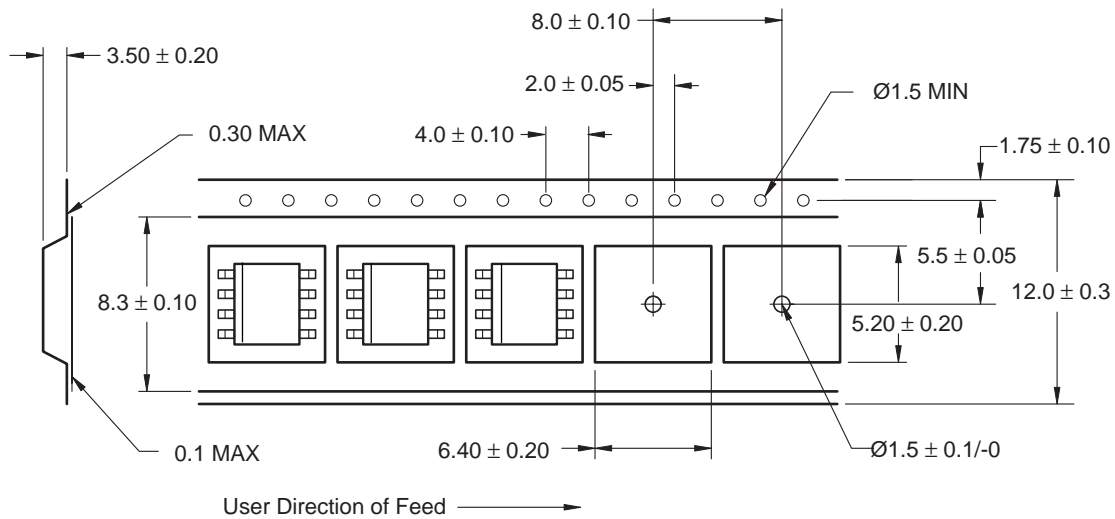

**Reflow Profile**

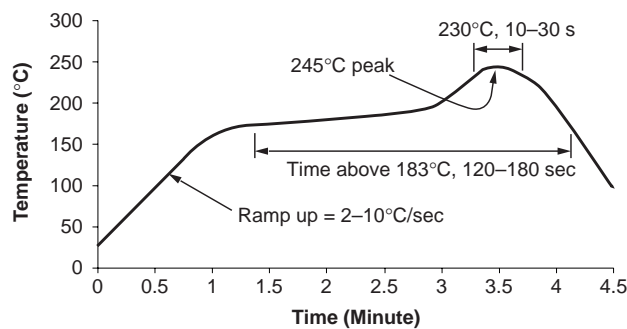

- Peak reflow temperature: 245°C (package surface temperature)
- Time of temperature higher than 183°C for 120–180 seconds
- One time soldering reflow is recommended



# LOW INPUT CURRENT HIGH GAIN SPLIT DARLINGTON OPTOCOUPLEDERS

---

<b>SINGLE CHANNEL:</b>	<b>HCPL-0700</b>	<b>HCPL-0701</b>
<b>DUAL CHANNEL:</b>	<b>HCPL-0730</b>	<b>HCPL-0731</b>

---

## DISCLAIMER

FAIRCHILD SEMICONDUCTOR RESERVES THE RIGHT TO MAKE CHANGES WITHOUT FURTHER NOTICE TO ANY PRODUCTS HEREIN TO IMPROVE RELIABILITY, FUNCTION OR DESIGN. FAIRCHILD DOES NOT ASSUME ANY LIABILITY ARISING OUT OF THE APPLICATION OR USE OF ANY PRODUCT OR CIRCUIT DESCRIBED HEREIN; NEITHER DOES IT CONVEY ANY LICENSE UNDER ITS PATENT RIGHTS, NOR THE RIGHTS OF OTHERS.

## LIFE SUPPORT POLICY

FAIRCHILD'S PRODUCTS ARE NOT AUTHORIZED FOR USE AS CRITICAL COMPONENTS IN LIFE SUPPORT DEVICES OR SYSTEMS WITHOUT THE EXPRESS WRITTEN APPROVAL OF THE PRESIDENT OF FAIRCHILD SEMICONDUCTOR CORPORATION. As used herein:

1. Life support devices or systems are devices or systems which, (a) are intended for surgical implant into the body, or (b) support or sustain life, and (c) whose failure to perform when properly used in accordance with instructions for use provided in the labeling, can be reasonably expected to result in a significant injury of the user.
2. A critical component in any component of a life support device or system whose failure to perform can be reasonably expected to cause the failure of the life support device or system, or to affect its safety or effectiveness.