

DUAL D-TYPE POSITIVE-EDGE-TRIGGERED FLIP-FLOPS WITH CLEAR AND PRESET

SCLS094D – DECEMBER 1982 – REVISED JULY 2003

- Wide Operating Voltage Range of 2 V to 6 V
- Outputs Can Drive Up To 10 LSTTL Loads
- Low Power Consumption, 40- μ A Max I_{CC}
- Typical $t_{pd} = 15$ ns
- ± 4 -mA Output Drive at 5 V
- Low Input Current of 1 μ A Max

description/ordering information

The 'HC74 devices contain two independent D-type positive-edge-triggered flip-flops. A low level at the preset (PRE) or clear (CLR) inputs sets or resets the outputs, regardless of the levels of the other inputs. When PRE and CLR are inactive (high), data at the data (D) input meeting the setup time requirements are transferred to the outputs on the positive-going edge of the clock (CLK) pulse. Clock triggering occurs at a voltage level and is not directly related to the rise time of CLK. Following the hold-time interval, data at the D input can be changed without affecting the levels at the outputs.

SN54HC74 . . . J OR W PACKAGE
SN74HC74 . . . D, DB, N, NS, OR PW PACKAGE
(TOP VIEW)

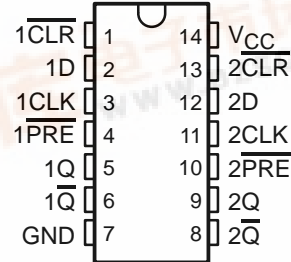

SN54HC74 . . . FK PACKAGE
(TOP VIEW)

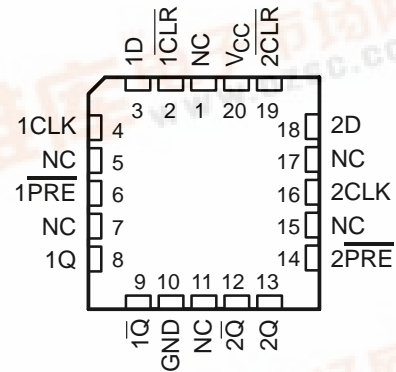

NC – No internal connection

ORDERING INFORMATION

T_A	PACKAGE†		ORDERABLE PART NUMBER	TOP-SIDE MARKING
-40°C to 85°C	PDIP – N	Tube of 25	SN74HC74N	SN74HC74N
	SOIC – D	Tube of 50	SN74HC74D	HC74
		Reel of 2500	SN74HC74DR	
		Reel of 250	SN74HC74DT	
	SOP – NS	Reel of 2000	SN74HC74NSR	HC74
	SSOP – DB	Reel of 2000	SN74HC74DBR	HC74
-55°C to 125°C	TSSOP – PW	Tube of 90	SN74HC74PW	HC74
		Reel of 2000	SN74HC74PWR	
		Reel of 250	SN74HC74PWT	
-55°C to 125°C	CDIP – J	Tube of 25	SNJ54HC74J	SNJ54HC74J
	CFP – W	Tube of 150	SNJ54HC74W	SNJ54HC74W
	LCCC – FK	Tube of 55	SNJ54HC74FK	SNJ54HC74FK

† Package drawings, standard packing quantities, thermal data, symbolization, and PCB design guidelines are available at www.ti.com/sc/package.

Please be aware that an important notice concerning availability, standard warranty, and use in critical applications of Texas Instruments semiconductor products and disclaimers thereto appears at the end of this data sheet.



PRODUCTION DATA information is current as of publication date. Products conform to specifications per the terms of Texas Instruments standard warranty. Production processing does not necessarily include testing of all parameters.



Copyright © 2003, Texas Instruments Incorporated
On products compliant to MIL-PRF-38535, all parameters are tested unless otherwise noted. On all other products, production processing does not necessarily include testing of all parameters.

SN54HC74, SN74HC74 DUAL D-TYPE POSITIVE-EDGE-TRIGGERED FLIP-FLOPS WITH CLEAR AND PRESET

SCLS094D – DECEMBER 1982 – REVISED JULY 2003

FUNCTION TABLE

INPUTS				OUTPUTS	
PRE	CLR	CLK	D	Q	\bar{Q}
L	H	X	X	H	L
H	L	X	X	L	H
L	L	X	X	H [†]	H [†]
H	H	↑	H	H	L
H	H	↑	L	L	H
H	H	L	X	Q ₀	\bar{Q} ₀

[†] This configuration is nonstable; that is, it does not persist when $\overline{\text{PRE}}$ or $\overline{\text{CLR}}$ returns to its inactive (high) level.

logic diagram (positive logic)

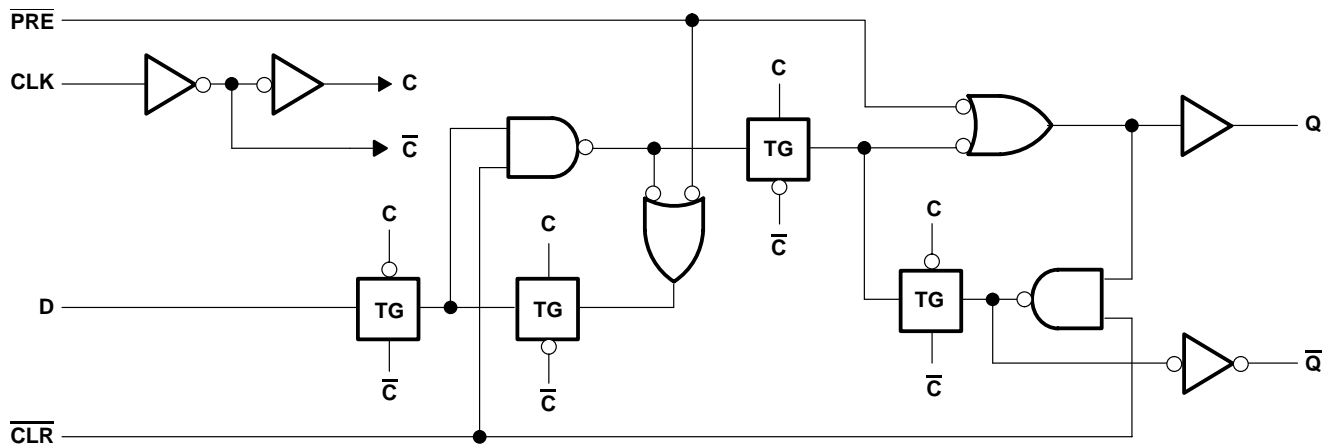

absolute maximum ratings over operating free-air temperature range (unless otherwise noted)[‡]

Supply voltage range, V_{CC}	-0.5 V to 7 V
Input clamp current, I_{IK} ($V_I < 0$ or $V_I > V_{CC}$) (see Note 1)	±20 mA
Output clamp current, I_{OK} ($V_O < 0$ or $V_O > V_{CC}$) (see Note 1)	±20 mA
Continuous output current, I_O ($V_O = 0$ to V_{CC})	±25 mA
Continuous current through V_{CC} or GND	±50 mA
Package thermal impedance, θ_{JA} (see Note 2):	
D package	86°C/W
DB package	96°C/W
N package	80°C/W
NS package	76°C/W
PW package	113°C/W
Storage temperature range, T_{stg}	-65°C to 150°C

[‡] Stresses beyond those listed under "absolute maximum ratings" may cause permanent damage to the device. These are stress ratings only, and functional operation of the device at these or any other conditions beyond those indicated under "recommended operating conditions" is not implied. Exposure to absolute-maximum-rated conditions for extended periods may affect device reliability.

NOTES: 1. The input and output voltage ratings may be exceeded if the input and output current ratings are observed.
2. The package thermal impedance is calculated in accordance with JESD 51-7.

SN54HC74, SN74HC74 DUAL D-TYPE POSITIVE-EDGE-TRIGGERED FLIP-FLOPS WITH CLEAR AND PRESET

SCLS094D – DECEMBER 1982 – REVISED JULY 2003

recommended operating conditions (see Note 3)

		SN54HC74			SN74HC74			UNIT
		MIN	NOM	MAX	MIN	NOM	MAX	
V _{CC}	Supply voltage	2	5	6	2	5	6	V
V _{IH}	High-level input voltage	V _{CC} = 2 V		1.5	1.5		V	
		V _{CC} = 4.5 V		3.15	3.15			
		V _{CC} = 6 V		4.2	4.2			
V _{IL}	Low-level input voltage	V _{CC} = 2 V			0.5		V	
		V _{CC} = 4.5 V			1.35			
		V _{CC} = 6 V			1.8			
V _I	Input voltage	0		V _{CC}	0		V _{CC}	V
V _O	Output voltage	0		V _{CC}	0		V _{CC}	V
Δt/Δv	Input transition rise/fall time	V _{CC} = 2 V			1000		ns	
		V _{CC} = 4.5 V			500			
		V _{CC} = 6 V			400			
T _A	Operating free-air temperature	-55		125	-40		85	°C

NOTE 3: All unused inputs of the device must be held at V_{CC} or GND to ensure proper device operation. Refer to the TI application report, *Implications of Slow or Floating CMOS Inputs*, literature number SCBA004.

electrical characteristics over recommended operating free-air temperature range (unless otherwise noted)

PARAMETER	TEST CONDITIONS	V _{CC}	T _A = 25°C			SN54HC74		SN74HC74		UNIT
			MIN	TYP	MAX	MIN	MAX	MIN	MAX	
V _{OH}	V _I = V _{IH} or V _{IL}	I _{OH} = -20 μA	2 V	1.9	1.998	1.9		1.9	V	
			4.5 V	4.4	4.499	4.4		4.4		
			6 V	5.9	5.999	5.9		5.9		
		I _{OH} = -4 mA	4.5 V	3.98	4.3	3.7		3.84		
		I _{OH} = -5.2 mA	6 V	5.48	5.8	5.2		5.34		
V _{OL}	V _I = V _{IH} or V _{IL}	I _{OL} = 20 μA	2 V		0.002	0.1	0.1		0.1	V
			4.5 V		0.001	0.1	0.1		0.1	
			6 V		0.001	0.1	0.1		0.1	
		I _{OL} = 4 mA	4.5 V		0.17	0.26	0.4		0.33	
		I _{OL} = 5.2 mA	6 V		0.15	0.26	0.4		0.33	
I _I	V _I = V _{CC} or 0	6 V		±0.1	±100	±1000		±1000	nA	
I _{CC}	V _I = V _{CC} or 0, I _O = 0	6 V			4	80		40	μA	
C _i		2 V to 6 V		3	10	10		10	pF	

SN54HC74, SN74HC74 DUAL D-TYPE POSITIVE-EDGE-TRIGGERED FLIP-FLOPS WITH CLEAR AND PRESET

SCLS094D – DECEMBER 1982 – REVISED JULY 2003

timing requirements over recommended operating free-air temperature range (unless otherwise noted)

		V _{CC}	T _A = 25°C		SN54HC74		SN74HC74		UNIT
			MIN	MAX	MIN	MAX	MIN	MAX	
f _{clock}	Clock frequency	2 V	6		4.2		5		MHz
		4.5 V	31		21		25		
		6 V	0	36	0	25	0	29	
t _w	Pulse duration	$\overline{\text{PRE}}$ or $\overline{\text{CLR}}$ low	2 V	100	150	125	ns		
			4.5 V	20	30	25			
			6 V	17	25	21			
	CLK high or low	2 V	80	120	100				
		4.5 V	16	24	20				
		6 V	14	20	17				
t _{su}	Setup time before CLK↑	Data	2 V	100	150	125	ns		
			4.5 V	20	30	25			
			6 V	17	25	21			
	$\overline{\text{PRE}}$ or $\overline{\text{CLR}}$ inactive	2 V	25	40	30				
		4.5 V	5	8	6				
		6 V	4	7	5				
t _h	Hold time, data after CLK↑	2 V	0	0	0	ns			
		4.5 V	0	0	0				
		6 V	0	0	0				

switching characteristics over recommended operating free-air temperature range, C_L = 50 pF (unless otherwise noted) (see Figure 1)

PARAMETER	FROM (INPUT)	TO (OUTPUT)	V _{CC}	T _A = 25°C			SN54HC74		SN74HC74		UNIT
				MIN	TYP	MAX	MIN	MAX	MIN	MAX	
f _{max}			2 V	6	10		4.2	5	MHz		
			4.5 V	31	50		21	25			
			6 V	36	60		25	29			
t _{pd}	$\overline{\text{PRE}}$ or $\overline{\text{CLR}}$	Q or $\overline{\text{Q}}$	2 V		70	230		345	290	ns	
			4.5 V		20	46		69	58		
			6 V		15	39		59	49		
	CLK	Q or $\overline{\text{Q}}$	2 V		70	175		250	220		
			4.5 V		20	35		50	44		
			6 V		15	30		42	37		
t _t		Q or $\overline{\text{Q}}$	2 V		28	75		110	95	ns	
			4.5 V		8	15		22	19		
			6 V		6	13		19	16		

operating characteristics, T_A = 25°C

PARAMETER	TEST CONDITIONS	TYP	UNIT
C _{pd} Power dissipation capacitance per flip-flop	No load	35	pF

SN54HC74, SN74HC74 DUAL D-TYPE POSITIVE-EDGE-TRIGGERED FLIP-FLOPS WITH CLEAR AND PRESET

SCLS094D – DECEMBER 1982 – REVISED JULY 2003

PARAMETER MEASUREMENT INFORMATION

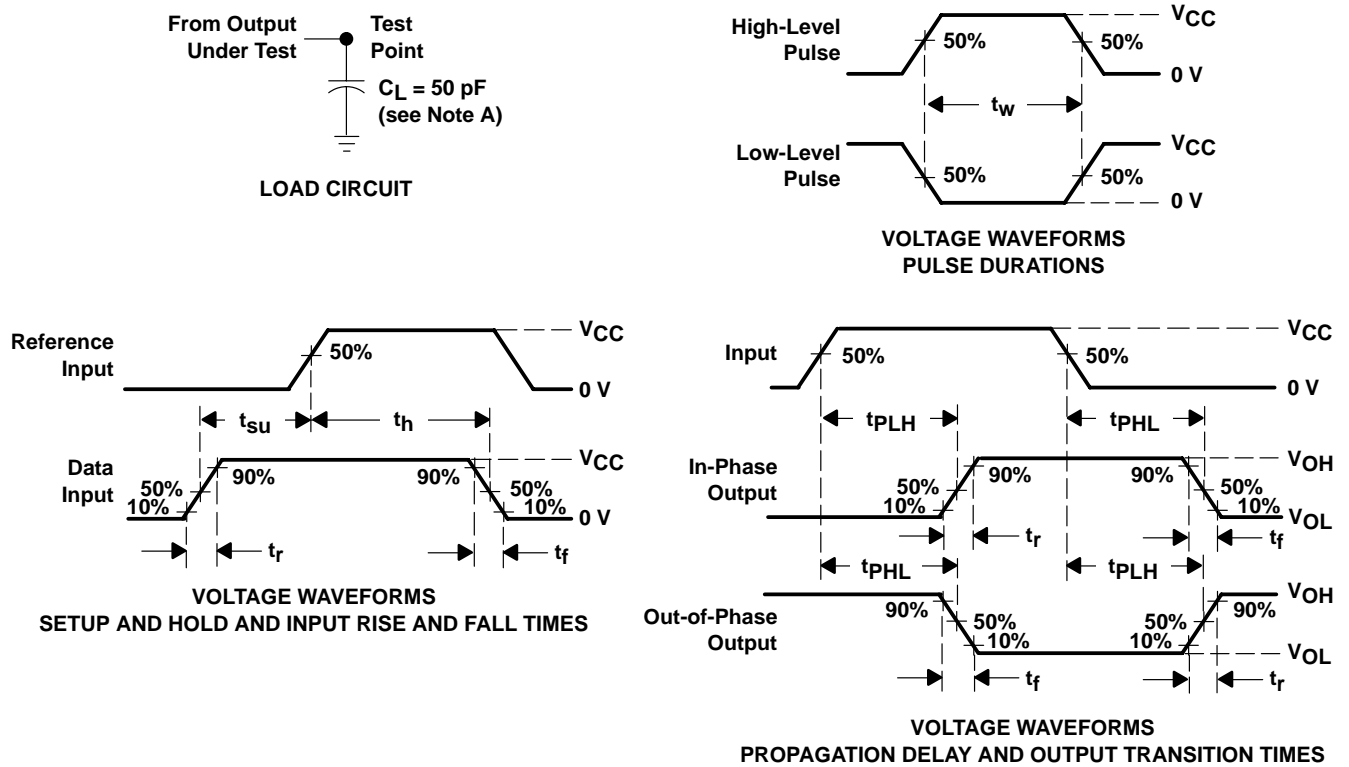

- NOTES:
- A. C_L includes probe and test-fixture capacitance.
 - B. Phase relationships between waveforms were chosen arbitrarily. All input pulses are supplied by generators having the following characteristics: $PRR \leq 1 \text{ MHz}$, $Z_O = 50 \Omega$, $t_r = 6 \text{ ns}$, $t_f = 6 \text{ ns}$.
 - C. For clock inputs, f_{max} is measured when the input duty cycle is 50%.
 - D. The outputs are measured one at a time with one input transition per measurement.
 - E. t_{PLH} and t_{PHL} are the same as t_{pd} .

Figure 1. Load Circuit and Voltage Waveforms

PACKAGING INFORMATION

Orderable Device	Status ⁽¹⁾	Package Type	Package Drawing	Pins	Package Qty	Eco Plan ⁽²⁾	Lead/Ball Finish	MSL Peak Temp ⁽³⁾
5962-8405601VCA	ACTIVE	CDIP	J	14	1	None	Call TI	Level-NC-NC-NC
5962-8405601VDA	ACTIVE	CFP	W	14	1	None	Call TI	Level-NC-NC-NC
84056012A	ACTIVE	LCCC	FK	20	1	None	Call TI	Level-NC-NC-NC
8405601CA	ACTIVE	CDIP	J	14	1	None	Call TI	Level-NC-NC-NC
8405601DA	ACTIVE	CFP	W	14	1	None	Call TI	Level-NC-NC-NC
JM38510/65302B2A	ACTIVE	LCCC	FK	20	1	None	Call TI	Level-NC-NC-NC
JM38510/65302BCA	ACTIVE	CDIP	J	14	1	None	Call TI	Level-NC-NC-NC
JM38510/65302BDA	ACTIVE	CFP	W	14	1	None	Call TI	Level-NC-NC-NC
SN54HC74J	ACTIVE	CDIP	J	14	1	None	Call TI	Level-NC-NC-NC
SN74HC74ADBLE	OBSOLETE	SSOP	DB	14		None	Call TI	Call TI
SN74HC74D	ACTIVE	SOIC	D	14	50	Pb-Free (RoHS)	CU NIPDAU	Level-2-260C-1 YEAR/ Level-1-235C-UNLIM
SN74HC74DBLE	OBSOLETE	SSOP	DB	14		None	Call TI	Call TI
SN74HC74DBR	ACTIVE	SSOP	DB	14	2000	Pb-Free (RoHS)	CU NIPDAU	Level-2-260C-1 YEAR/ Level-1-235C-UNLIM
SN74HC74DR	ACTIVE	SOIC	D	14	2500	Green (RoHS & no Sb/Br)	CU NIPDAU	Level-1-260C-UNLIM
SN74HC74DT	ACTIVE	SOIC	D	14	250	Pb-Free (RoHS)	CU NIPDAU	Level-2-260C-1 YEAR/ Level-1-235C-UNLIM
SN74HC74N	ACTIVE	PDIP	N	14	25	Pb-Free (RoHS)	CU NIPDAU	Level-NC-NC-NC
SN74HC74N3	OBSOLETE	PDIP	N	14		None	Call TI	Call TI
SN74HC74NSR	ACTIVE	SO	NS	14	2000	Pb-Free (RoHS)	CU NIPDAU	Level-2-260C-1 YEAR/ Level-1-235C-UNLIM
SN74HC74PW	ACTIVE	TSSOP	PW	14	90	Pb-Free (RoHS)	CU NIPDAU	Level-1-250C-UNLIM
SN74HC74PWLE	OBSOLETE	TSSOP	PW	14		None	Call TI	Call TI
SN74HC74PWR	ACTIVE	TSSOP	PW	14	2000	Pb-Free (RoHS)	CU NIPDAU	Level-1-250C-UNLIM
SN74HC74PWT	ACTIVE	TSSOP	PW	14	250	Pb-Free (RoHS)	CU NIPDAU	Level-1-250C-UNLIM
SNJ54HC74FK	ACTIVE	LCCC	FK	20	1	None	Call TI	Level-NC-NC-NC
SNJ54HC74J	ACTIVE	CDIP	J	14	1	None	Call TI	Level-NC-NC-NC
SNJ54HC74W	ACTIVE	CFP	W	14	1	None	Call TI	Level-NC-NC-NC

⁽¹⁾ The marketing status values are defined as follows:

ACTIVE: Product device recommended for new designs.

LIFEBUY: TI has announced that the device will be discontinued, and a lifetime-buy period is in effect.

NRND: Not recommended for new designs. Device is in production to support existing customers, but TI does not recommend using this part in a new design.

PREVIEW: Device has been announced but is not in production. Samples may or may not be available.

OBSOLETE: TI has discontinued the production of the device.

⁽²⁾ Eco Plan - May not be currently available - please check <http://www.ti.com/productcontent> for the latest availability information and additional product content details.

None: Not yet available Lead (Pb-Free).

Pb-Free (RoHS): TI's terms "Lead-Free" or "Pb-Free" mean semiconductor products that are compatible with the current RoHS requirements for all 6 substances, including the requirement that lead not exceed 0.1% by weight in homogeneous materials. Where designed to be soldered at high temperatures, TI Pb-Free products are suitable for use in specified lead-free processes.

Green (RoHS & no Sb/Br): TI defines "Green" to mean "Pb-Free" and in addition, uses package materials that do not contain halogens, including bromine (Br) or antimony (Sb) above 0.1% of total product weight.

⁽³⁾ MSL, Peak Temp. -- The Moisture Sensitivity Level rating according to the JEDEC industry standard classifications, and peak solder temperature.

Important Information and Disclaimer: The information provided on this page represents TI's knowledge and belief as of the date that it is provided. TI bases its knowledge and belief on information provided by third parties, and makes no representation or warranty as to the accuracy of such information. Efforts are underway to better integrate information from third parties. TI has taken and continues to take reasonable steps to provide representative and accurate information but may not have conducted destructive testing or chemical analysis on incoming materials and chemicals. TI and TI suppliers consider certain information to be proprietary, and thus CAS numbers and other limited information may not be available for release.

In no event shall TI's liability arising out of such information exceed the total purchase price of the TI part(s) at issue in this document sold by TI to Customer on an annual basis.

J (R-GDIP-T**)

14 LEADS SHOWN

CERAMIC DUAL IN-LINE PACKAGE



DIM \ PINS **	14	16	18	20
A	0.300 (7,62) BSC	0.300 (7,62) BSC	0.300 (7,62) BSC	0.300 (7,62) BSC
B MAX	0.785 (19,94)	.840 (21,34)	0.960 (24,38)	1.060 (26,92)
B MIN	—	—	—	—
C MAX	0.300 (7,62)	0.300 (7,62)	0.310 (7,87)	0.300 (7,62)
C MIN	0.245 (6,22)	0.245 (6,22)	0.220 (5,59)	0.245 (6,22)



4040083/F 03/03

- NOTES:
- A. All linear dimensions are in inches (millimeters).
 - B. This drawing is subject to change without notice.
 - C. This package is hermetically sealed with a ceramic lid using glass frit.
 - D. Index point is provided on cap for terminal identification only on press ceramic glass frit seal only.
 - E. Falls within MIL STD 1835 GDIP1-T14, GDIP1-T16, GDIP1-T18 and GDIP1-T20.

MECHANICAL DATA

W (R-GDFP-F14)

CERAMIC DUAL FLATPACK

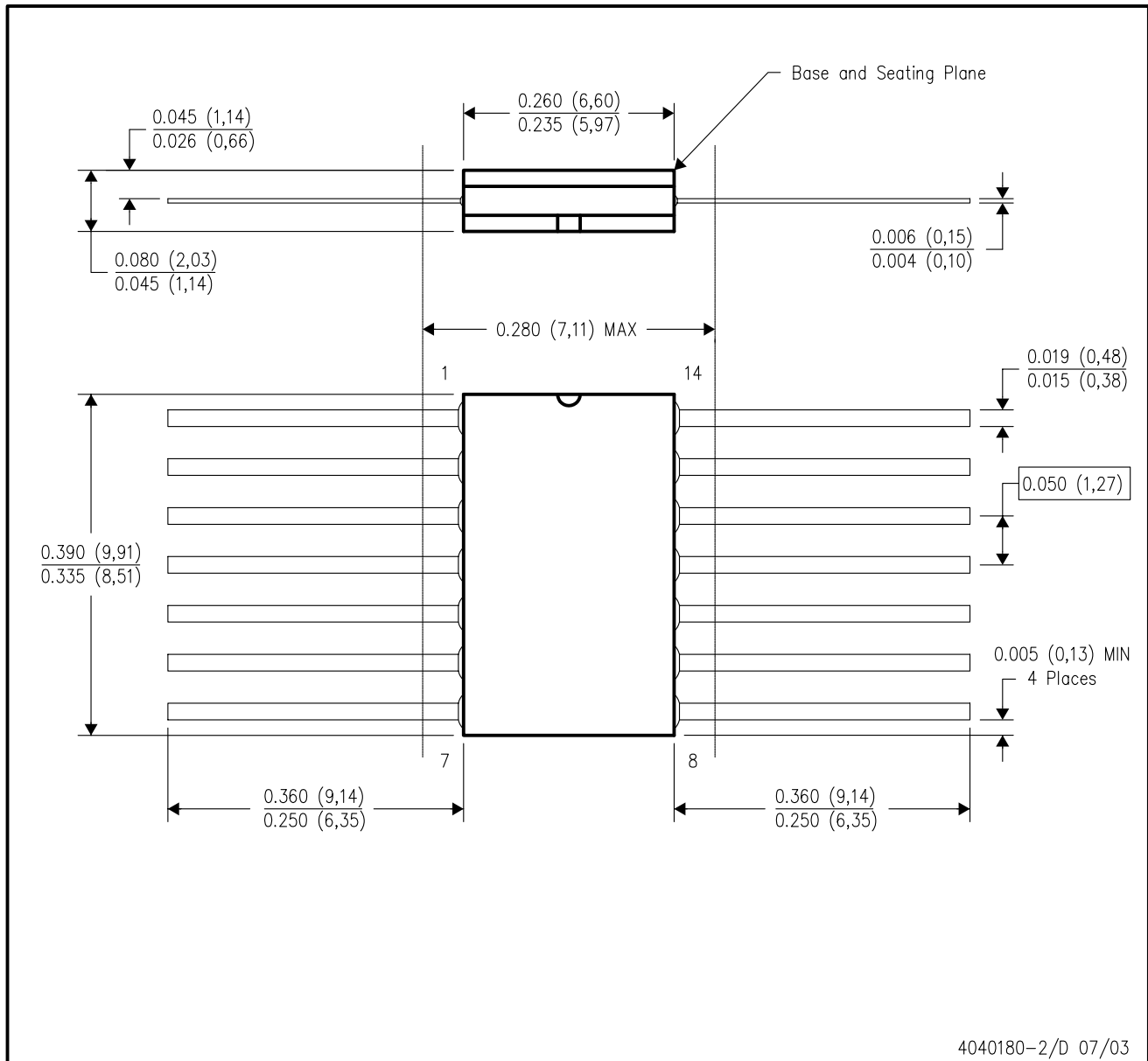

- NOTES:
- A. All linear dimensions are in inches (millimeters).
 - B. This drawing is subject to change without notice.
 - C. This package can be hermetically sealed with a ceramic lid using glass frit.
 - D. Index point is provided on cap for terminal identification only.
 - E. Falls within MIL STD 1835 GDFP1-F14 and JEDEC MO-092AB

MECHANICAL DATA

MLCC006B – OCTOBER 1996

FK (S-CQCC-N**)

LEADLESS CERAMIC CHIP CARRIER

28 TERMINAL SHOWN



- NOTES:
- All linear dimensions are in inches (millimeters).
 - This drawing is subject to change without notice.
 - This package can be hermetically sealed with a metal lid.
 - The terminals are gold plated.
 - Falls within JEDEC MS-004

4040140/D 10/96

MECHANICAL DATA

N (R-PDIP-T**)

16 PINS SHOWN

PLASTIC DUAL-IN-LINE PACKAGE

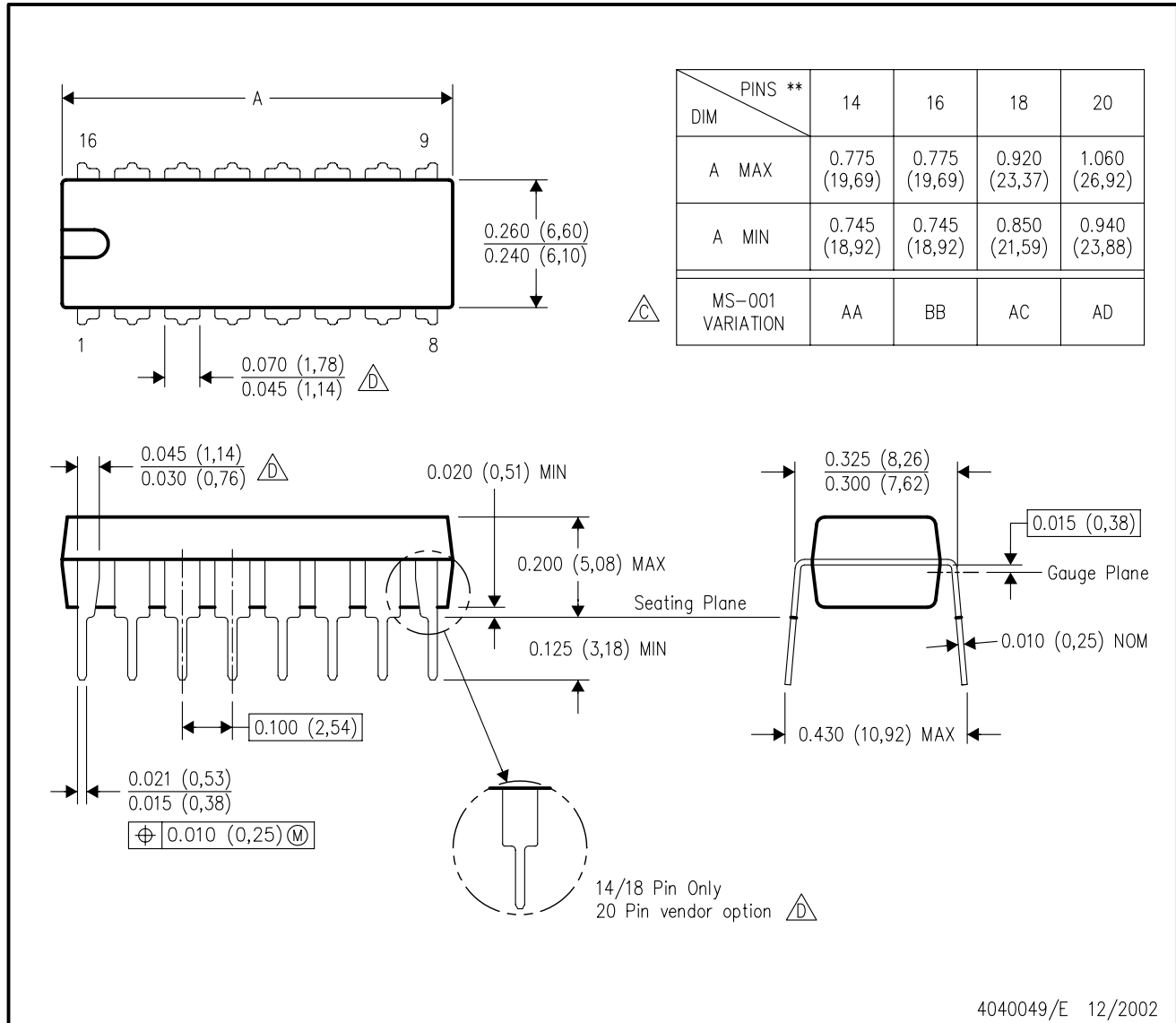

- NOTES:
- A. All linear dimensions are in inches (millimeters).
 - B. This drawing is subject to change without notice.
 - Falls within JEDEC MS-001, except 18 and 20 pin minimum body length (Dim A).
 - The 20 pin end lead shoulder width is a vendor option, either half or full width.

MECHANICAL DATA

D (R-PDSO-G14)

PLASTIC SMALL-OUTLINE PACKAGE

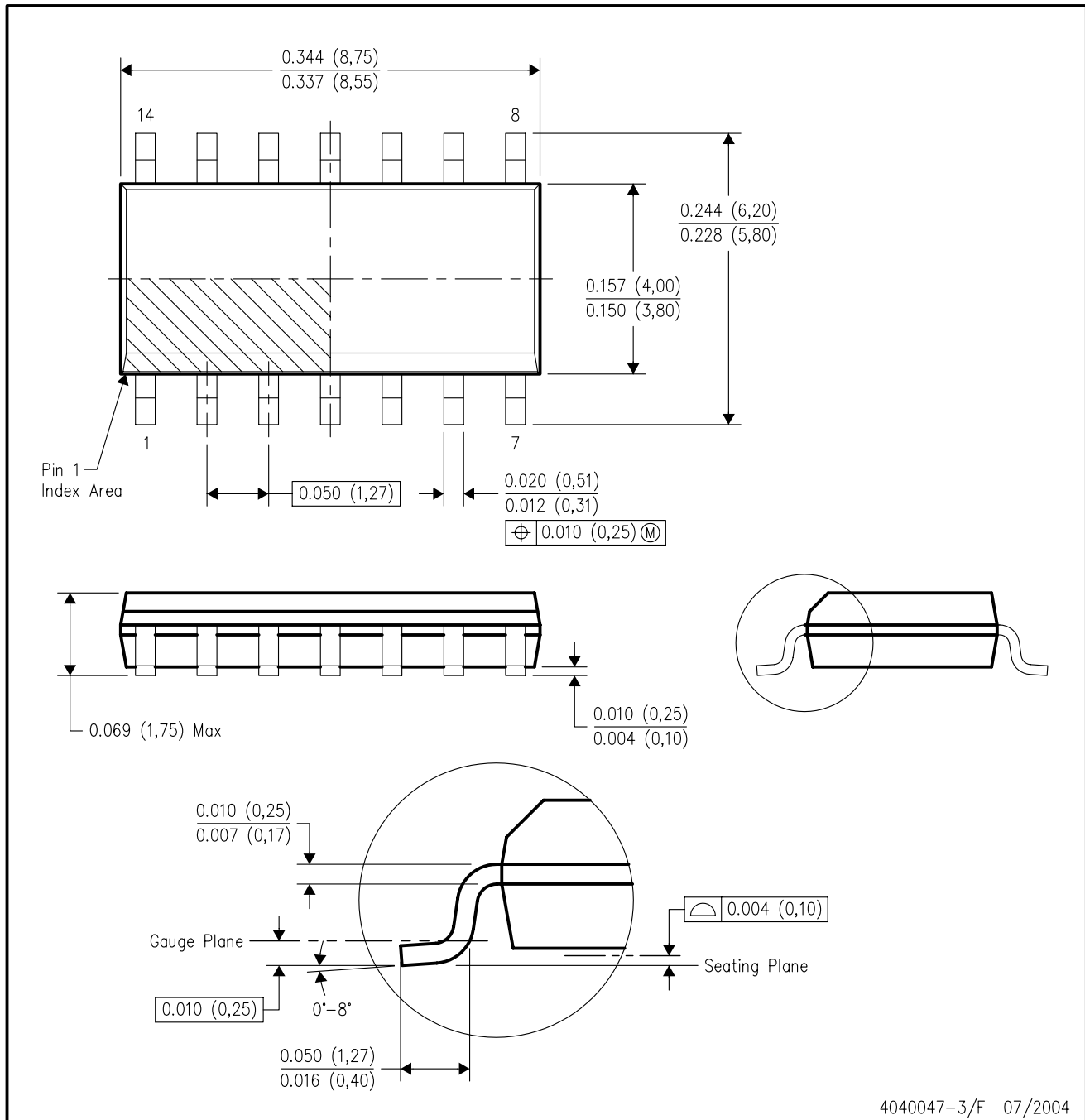

- NOTES:
- All linear dimensions are in inches (millimeters).
 - This drawing is subject to change without notice.
 - Body dimensions do not include mold flash or protrusion not to exceed 0.006 (0,15).
 - Falls within JEDEC MS-012 variation AB.

MECHANICAL DATA

NS (R-PDSO-G)**

PLASTIC SMALL-OUTLINE PACKAGE

14-PINS SHOWN

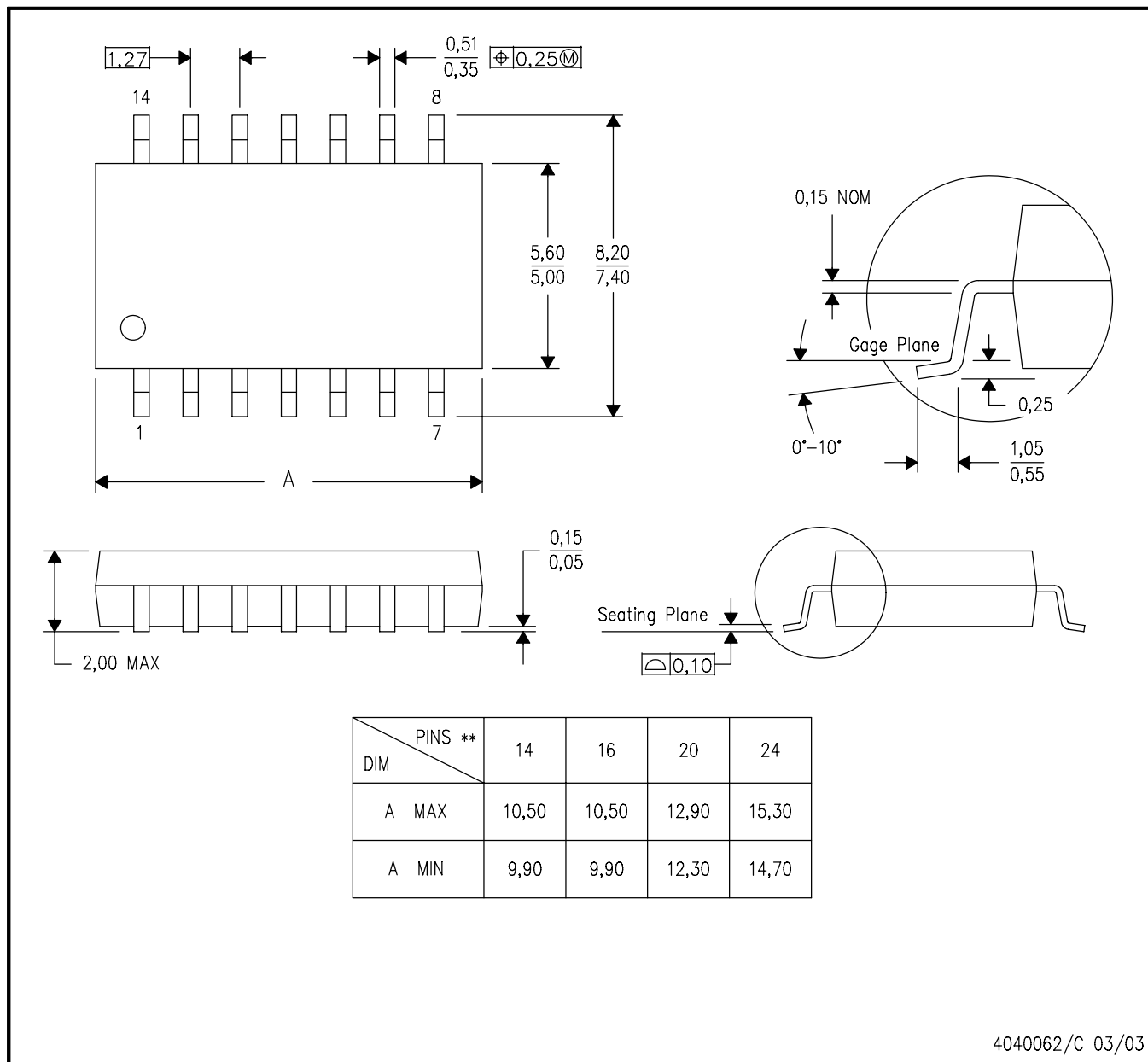

4040062/C 03/03

- NOTES:
- A. All linear dimensions are in millimeters.
 - B. This drawing is subject to change without notice.
 - C. Body dimensions do not include mold flash or protrusion, not to exceed 0,15.

MECHANICAL DATA

MSS0002E – JANUARY 1995 – REVISED DECEMBER 2001

DB (R-PDSO-G**)

PLASTIC SMALL-OUTLINE

28 PINS SHOWN

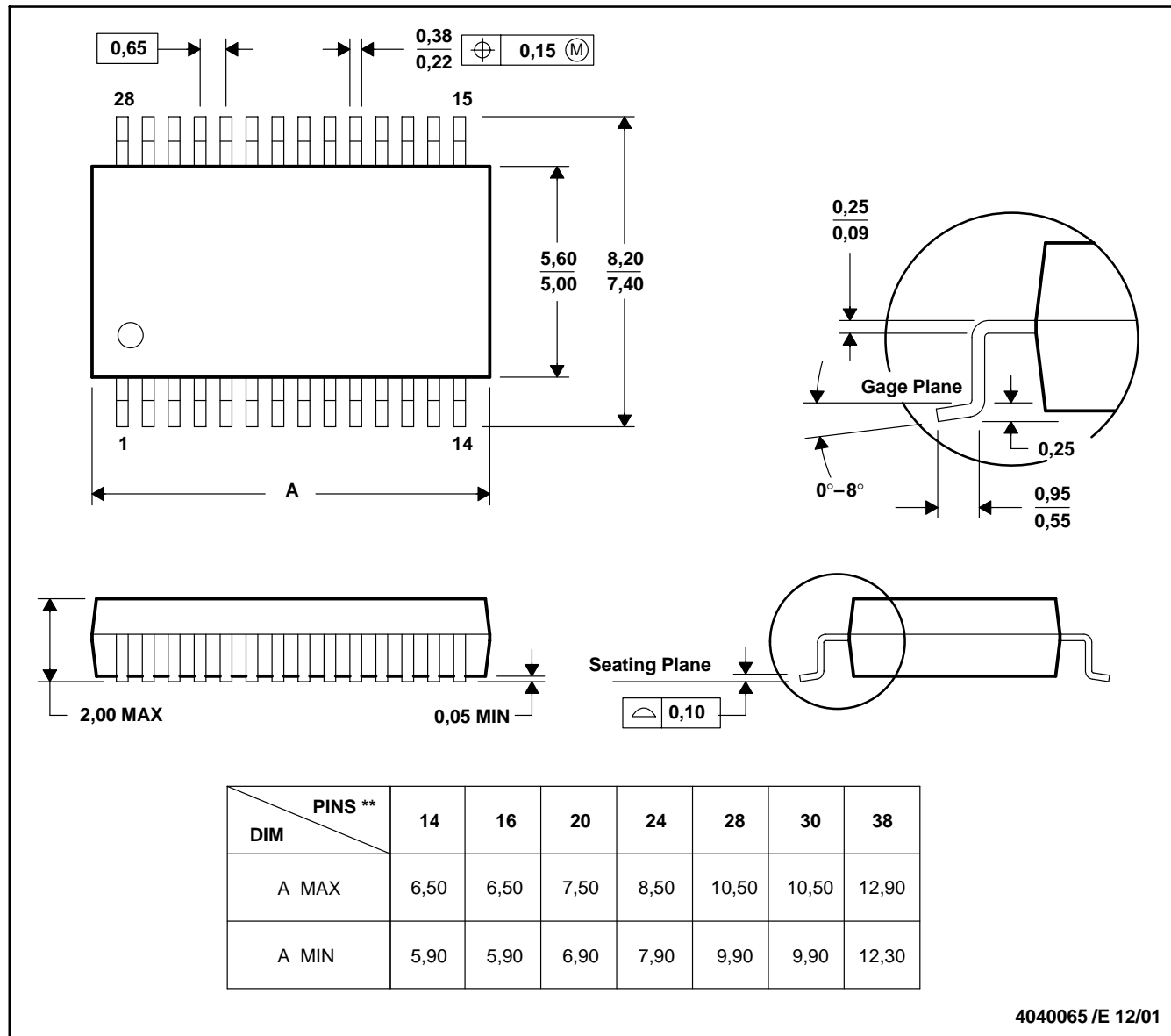

- NOTES: A. All linear dimensions are in millimeters.
 B. This drawing is subject to change without notice.
 C. Body dimensions do not include mold flash or protrusion not to exceed 0,15.
 D. Falls within JEDEC MO-150

MECHANICAL DATA

MTSS001C – JANUARY 1995 – REVISED FEBRUARY 1999

PW (R-PDSO-G)**

PLASTIC SMALL-OUTLINE PACKAGE

14 PINS SHOWN

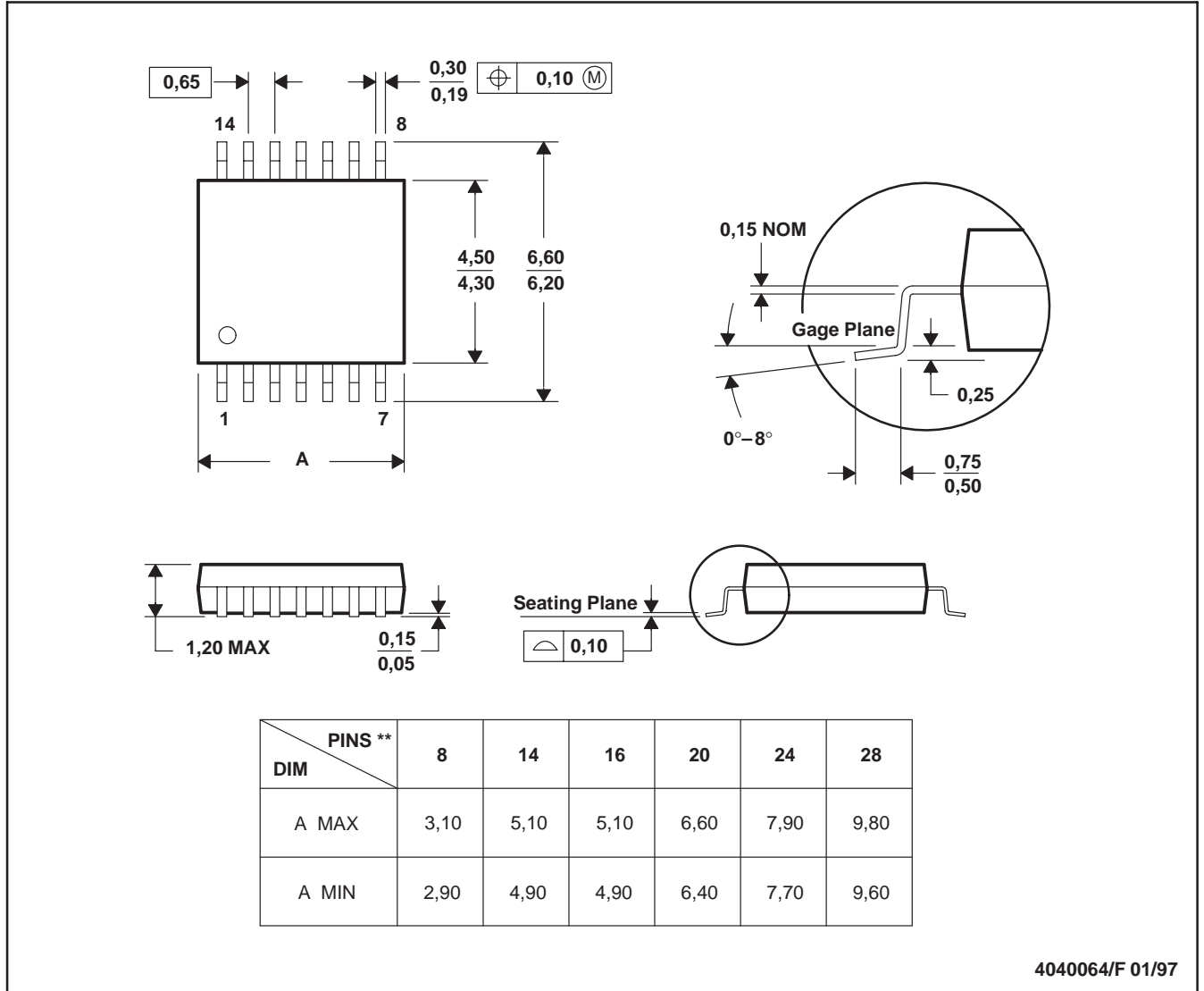

4040064/F 01/97

- NOTES: A. All linear dimensions are in millimeters.
 B. This drawing is subject to change without notice.
 C. Body dimensions do not include mold flash or protrusion not to exceed 0,15.
 D. Falls within JEDEC MO-153

IMPORTANT NOTICE

Texas Instruments Incorporated and its subsidiaries (TI) reserve the right to make corrections, modifications, enhancements, improvements, and other changes to its products and services at any time and to discontinue any product or service without notice. Customers should obtain the latest relevant information before placing orders and should verify that such information is current and complete. All products are sold subject to TI's terms and conditions of sale supplied at the time of order acknowledgment.

TI warrants performance of its hardware products to the specifications applicable at the time of sale in accordance with TI's standard warranty. Testing and other quality control techniques are used to the extent TI deems necessary to support this warranty. Except where mandated by government requirements, testing of all parameters of each product is not necessarily performed.

TI assumes no liability for applications assistance or customer product design. Customers are responsible for their products and applications using TI components. To minimize the risks associated with customer products and applications, customers should provide adequate design and operating safeguards.

TI does not warrant or represent that any license, either express or implied, is granted under any TI patent right, copyright, mask work right, or other TI intellectual property right relating to any combination, machine, or process in which TI products or services are used. Information published by TI regarding third-party products or services does not constitute a license from TI to use such products or services or a warranty or endorsement thereof. Use of such information may require a license from a third party under the patents or other intellectual property of the third party, or a license from TI under the patents or other intellectual property of TI.

Reproduction of information in TI data books or data sheets is permissible only if reproduction is without alteration and is accompanied by all associated warranties, conditions, limitations, and notices. Reproduction of this information with alteration is an unfair and deceptive business practice. TI is not responsible or liable for such altered documentation.

Resale of TI products or services with statements different from or beyond the parameters stated by TI for that product or service voids all express and any implied warranties for the associated TI product or service and is an unfair and deceptive business practice. TI is not responsible or liable for any such statements.

Following are URLs where you can obtain information on other Texas Instruments products and application solutions:

Products		Applications	
Amplifiers	amplifier.ti.com	Audio	www.ti.com/audio
Data Converters	dataconverter.ti.com	Automotive	www.ti.com/automotive
DSP	dsp.ti.com	Broadband	www.ti.com/broadband
Interface	interface.ti.com	Digital Control	www.ti.com/digitalcontrol
Logic	logic.ti.com	Military	www.ti.com/military
Power Mgmt	power.ti.com	Optical Networking	www.ti.com/opticalnetwork
Microcontrollers	microcontroller.ti.com	Security	www.ti.com/security
		Telephony	www.ti.com/telephony
		Video & Imaging	www.ti.com/video
		Wireless	www.ti.com/wireless

Mailing Address: Texas Instruments
Post Office Box 655303 Dallas, Texas 75265