

**SIEMENS**

**GaAs MMIC**

**CGY 60**

*Datasheet*

- \* Low noise preamplifier for mobile communication (PCN, DECT, GSM) in 2.7V to 6V systems
- \* Biased monolithic microwave IC (MMIC)  
Matched to 50Ω for 1.7 to 2GHz
- \* Easily matchable to 50Ω for lower frequencies (i.e. GSM-application)
- \* No bias coil needed
- \* Low noise figure and high gain (typ. NF=1.9dB, G=12.5dB @ 3V, 1.85GHz)
- \* Low power consumption
- \* Frequency range 200 MHz ... 2.5 GHz

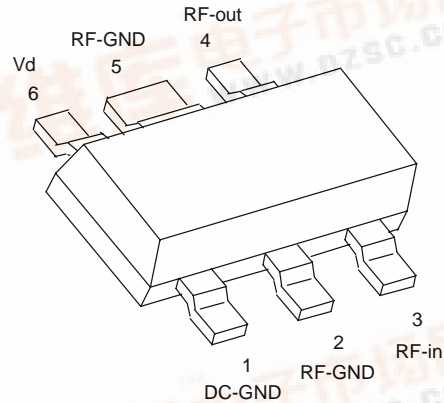

ESD: **E**lectrostatic discharge sensitive device, observe handling precautions!

Type	Marking	Ordering code (taped)	Package 1)
CGY 60	Y7s	Q62702G-39	MW-6

Maximum ratings	Symbol		Unit
Drain voltage	$V_D$	8	V
Channel temperature	$T_{Ch}$	150	°C
Storage temperature range	$T_{sta}$	-55...+150	°C
Total power dissipation ( $T_S \leq 132^\circ\text{C}$ ) <sup>2)</sup>	$P_{tot}$	80	mW
<b>Thermal resistance</b>			
Channel-soldering point (GND)	$R_{thChS}$	$\leq 220$	K/W
Channel-ambient <sup>3)</sup>	$R_{thChA}$	$< 300$	K/W

1) Dimensions see chapter Package Outlines  
 2) Please care for sufficient heat dissipation on the pcb!  
 3) Package mounted on alumina 15 mm x 16.7 mm x 0.7 mm



## Electrical characteristics of CGY60 in GSM application circuit

$T_A = 25^\circ\text{C}$

$f=950\text{MHz}$

$R_S = R_L = 50 \Omega$

unless otherwise specified

Characteristics	Symbol	min	typ	max	Unit
Drain current	$I_D$	-	6	9	mA
Power Gain Ud = 3V Ud = 5V	$G$	- -	15.5 17	- -	dB
Noise figure Ud = 3V Ud = 5V	$F$	- -	1.35 1.30	- -	dB
Input return loss Ud = 3V Ud = 5V	$RL_{in}$	- -	10 10	- -	dB
Output return loss Ud = 3V Ud = 5V	$RL_{out}$	- -	11 11	- -	dB
Third order input intercept point two-tone intermodulation test f1 = 950MHz, f2 = 951MHz Pin = -20dBm (both carriers) Ud = 3V Ud = 5V	$IP_3$	- -	-3 -1	- -	dBm
Input power at 1dB gain compression Ud = 3V Ud = 5V	$P_{-1dB}$	- -	-10 -8	- -	dBm

**Electrical characteristics in PCN-, DECT-application circuit**

$T_A = 25^\circ\text{C}$

$f=1850\text{MHz}$

$R_S = R_L = 50 \Omega$

unless otherwise specified

Characteristics	Symbol	min	typ	max	Unit
Drain current	$I_D$	-	6	9	mA
Power Gain Ud = 3V Ud = 5V	$G$	- -	12.5 13.5	- -	dB
Noise figure Ud = 3V Ud = 5V	$F$	- -	1.90 1.85	- -	dB
Input return loss Ud = 3V Ud = 5V	$RL_{in}$	- -	14.5 14.5	- -	dB
Output return loss Ud = 3V Ud = 5V	$RL_{out}$	- -	14 14	- -	dB
Third order input intercept point two-tone intermodulation test f1 = 1850MHz, f2 = 1851MHz Pin = -20dBm (both carriers) Ud = 3V Ud = 5V	$IP_3$	- -	0 2	- -	dBm
Input power at 1dB gain compression Ud = 3V Ud = 5V	$P_{-1dB}$	- -	-7 -5	- -	dBm

Application Circuit for measuring S- and Noise-parameters

f = 200MHz to 2GHz

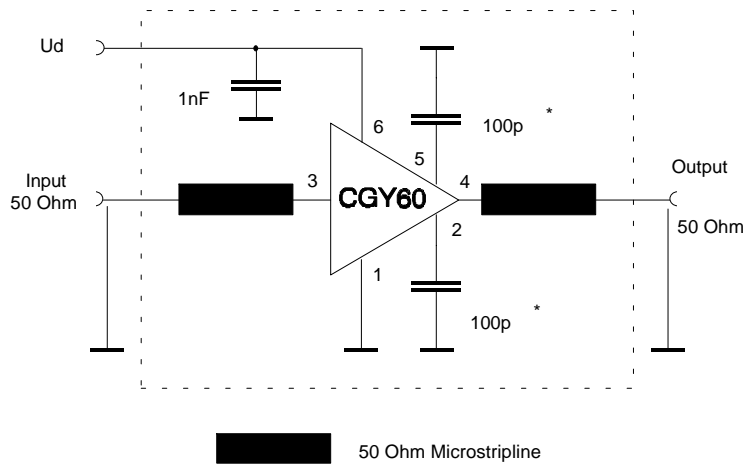

\* Use 12 to 15pF for DECT - or PCN - applications

900MHz Application (GSM)

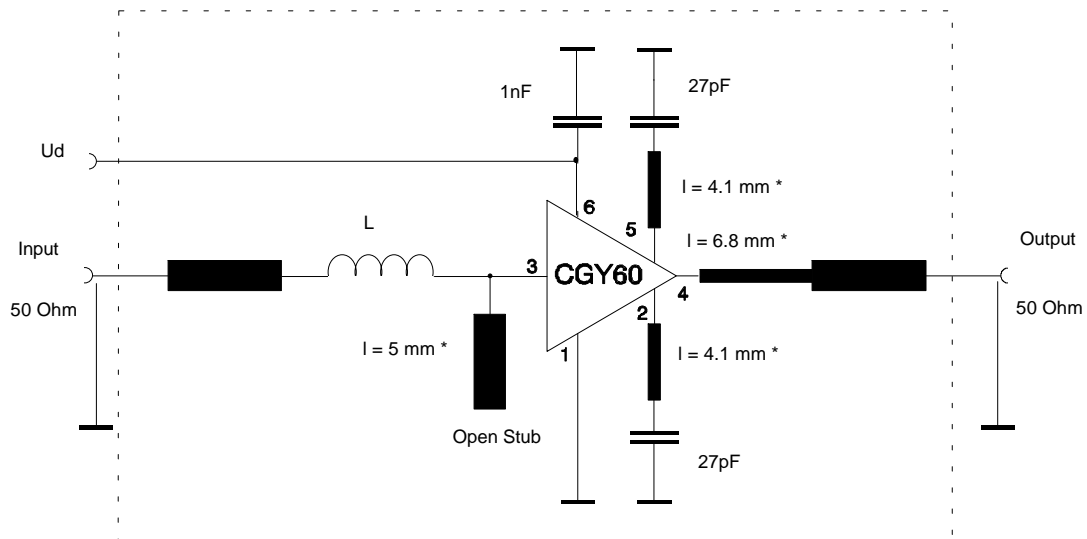

50 Ohm Microstripline

120 Ohm

L = discrete inductor 15nH, Type SIMID01, Ord.- No: B82412-A3150-M

$$V = \frac{1}{\sqrt{\epsilon_{\text{reff}}}}$$

PCB - Layouts for Application Circuits

PCN -, DECT - application board:

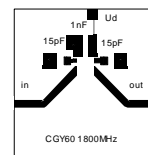
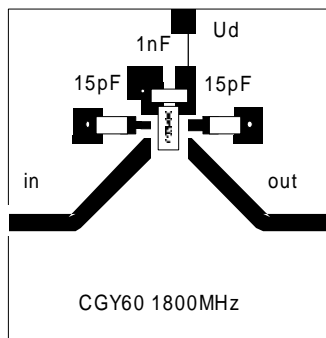

actual size  
( 20 x 20 mm )

GSM - application board:

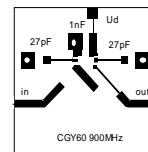
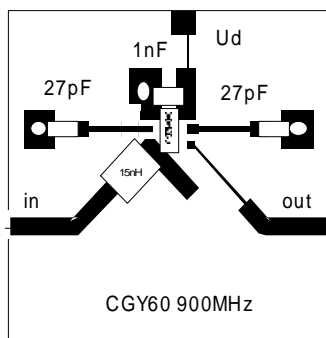

actual size  
( 20 x 20 mm )

PCB - data: Glass fiber teflon board (double sided) TACONIC TLX-9-0150-CH/CH  
 $\epsilon_r = 2.45$  thickness = 0.4mm

Typical S- and Noise-Parameters

$$V_D = 3 \text{ V} \quad Z_0 = 50 \Omega$$

f/GHz	S11		S21		S12		S22	
	MAG	ANG	MAG	ANG	MAG	ANG	MAG	ANG
0.1	0.97	-5	2.98	-135	0.005	80	0.74	-34
0.2	0.97	-9	3.85	-162	0.009	77	0.51	-44
0.3	0.96	-14	4.13	-177	0.013	74	0.41	-47
0.4	0.94	-19	4.27	172	0.017	73	0.35	-48
0.5	0.93	-23	4.35	163	0.021	71	0.33	-49
0.6	0.91	-29	4.40	155	0.026	67	0.31	-51
0.7	0.88	-34	4.45	148	0.029	65	0.30	-54
0.8	0.85	-40	4.48	140	0.033	63	0.29	-58
0.9	0.81	-46	4.51	132	0.037	60	0.29	-63
1.0	0.76	-52	4.55	125	0.042	54	0.28	-69
1.1	0.71	-59	4.60	117	0.045	50	0.27	-74
1.2	0.64	-66	4.62	110	0.048	46	0.26	-80
1.3	0.58	-74	4.63	102	0.051	41	0.26	-86
1.4	0.51	-83	4.61	94	0.053	36	0.25	-93
1.5	0.43	-93	4.58	85	0.054	31	0.24	-101
1.6	0.34	-106	4.51	77	0.055	26	0.23	-109
1.7	0.26	-122	4.40	69	0.055	20	0.22	-118
1.8	0.19	-149	4.30	60	0.054	15	0.21	-128
1.9	0.15	172	4.13	51	0.051	11	0.20	-140
2.0	0.18	131	3.94	43	0.049	5	0.19	-151
2.1	0.24	106	3.73	35	0.046	2.5	0.18	-163
2.2	0.32	90	3.56	27	0.043	-5	0.18	177
2.3	0.39	78	3.33	20	0.038	-9	0.18	170
2.4	0.46	69	3.09	13	0.033	-11	0.18	160
2.5	0.52	61	2.87	5	0.028	-12	0.19	151

f	F <sub>min</sub>	Γ <sub>opt</sub>	R <sub>N</sub>
GHz	dB	MAG -	Ω
		ANG deg	
0.9	1.27	0.70	47.8
1.3	1.35	0.63	32.7
1.8	1.50	0.42	18.2
2.0	1.60	0.30	15.0

Typical S- and Noise-Parameters

$V_D = 5\text{ V}$

$Z_0 = 50\Omega$

f/GHz	S11		S21		S12		S22	
	MAG	ANG	MAG	ANG	MAG	ANG	MAG	ANG
0.1	0.97	-4	3.58	-137	0.005	74	0.72	-31
0.2	0.97	-9	4.49	-164	0.009	75	0.52	-37
0.3	0.96	-14	4.78	-178	0.013	74	0.44	-38
0.4	0.94	-18	4.91	171	0.017	71	0.39	-39
0.5	0.93	-23	4.96	163	0.021	70	0.37	-40
0.6	0.90	-28	5.02	154	0.024	67	0.36	-42
0.7	0.88	-34	5.09	147	0.028	64	0.35	-45
0.8	0.85	-39	5.11	139	0.032	62	0.34	-50
0.9	0.81	-45	5.14	132	0.036	60	0.34	-54
1.0	0.76	-51	5.16	125	0.041	55	0.33	-59
1.1	0.71	-58	5.23	118	0.044	50	0.32	-64
1.2	0.65	-65	5.25	110	0.046	45	0.31	-70
1.3	0.59	-72	5.25	102	0.049	42	0.30	-75
1.4	0.52	-81	5.25	95	0.050	37	0.29	-81
1.5	0.44	-90	5.21	87	0.052	32	0.27	-88
1.6	0.36	-103	5.15	78	0.052	27	0.26	-95
1.7	0.28	-118	5.05	70	0.052	23	0.24	-102
1.8	0.20	-140	4.93	62	0.051	17	0.22	-111
1.9	0.16	-176	4.77	53	0.050	13	0.20	-121
2.0	0.17	141	4.57	45	0.047	8	0.18	-131
2.1	0.23	113	4.36	37	0.045	5	0.17	-142
2.2	0.31	95	4.18	29	0.042	-2	0.16	-158
2.3	0.38	82	3.92	21	0.037	-6	0.14	-173
2.4	0.45	72	3.66	14	0.032	-8	0.14	174
2.5	0.52	64	3.39	7	0.027	-9	0.14	162

f	F <sub>min</sub>	$\Gamma_{opt}$	R <sub>n</sub>
GHz	dB	MAG -	$\Omega$
		ANG deg	
0.9	1.23	0.69	47.7
1.3	1.32	0.67	33.3
1.8	1.45	0.45	18.6
2.0	1.53	0.32	15.2