

**INTEGRATED CIRCUITS**

# DATA SHEET

## **TDA8002** IC card interface

Product specification  
Supersedes data of 1997 Mar 13  
File under Integrated Circuits, IC02

1997 Nov 04

## IC card interface

## TDA8002

### FEATURES

- Single supply voltage interface (3.3 or 5 V environment)
- Low-power sleep mode
- Three specific protected half-duplex bidirectional buffered I/O lines
- $V_{CC}$  regulation (5 V  $\pm$ 5%,  $I_{CC}$  <65 mA at  $V_{DD}$  = 5 V, with controlled rise and fall times)
- Thermal and short-circuit protections with current limitations
- Automatic ISO 7816 activation and deactivation sequences
- Enhanced ESD protections on card side (>6 kV)
- Clock generation for the card up to 12 MHz with synchronous frequency changes
- Clock generation up to 20 MHz (auxiliary clock)
- Synchronous and asynchronous cards (memory and smart cards)
- ISO 7816, GSM11.11 compatibility and EMV (Europay, Mastercard, Visa) compliant
- Step-up converter for  $V_{CC}$  generation

- Supply supervisor for spikes elimination and emergency deactivation.

### APPLICATIONS

- IC card readers for:
  - GSM applications
  - banking
  - electronic payment
  - identification
  - Pay TV
  - road tolling.

### GENERAL DESCRIPTION

The TDA8002 is a complete low-power, analog interface for asynchronous and synchronous cards. It can be placed between the card and the microcontroller. It performs all supply, protection and control functions. It is directly compatible with ISO 7816, GSM11.11 and EMV specifications.

### QUICK REFERENCE DATA

SYMBOL	PARAMETER	CONDITIONS	MIN.	TYP.	MAX.	UNIT
<b>Supply</b>						
$V_{DDA}$	analog supply voltage		3.0	5	6.5	V
$I_{DD}$	supply current	sleep mode	–	–	150	$\mu$ A
		idle mode; $f_{CLK}$ = 2.5 MHz; $f_{CLKOUT}$ = 10 MHz; $V_{DD}$ = 5 V	–	–	6	mA
		active mode; $f_{CLK}$ = 2.5 MHz; $f_{CLKOUT}$ = 10 MHz; $V_{DD}$ = 5 V	–	–	9	mA
		active mode; $f_{CLK}$ = 2.5 MHz; $f_{CLKOUT}$ = 10 MHz; $V_{DD}$ = 3 V	–	–	12	mA
<b>Card supply</b>						
$V_{CC(O)}$	output voltage	DC load <65 mA	4.75	–	5.25	V
$I_{CC(O)}$	output current	$V_{CC}$ short-circuited to GND	–	–	100	mA
<b>General</b>						
$f_{CLK}$	card clock frequency		0	–	12	MHz
$T_{de}$	deactivation cycle time		60	80	100	$\mu$ s
$P_{tot}$	continuous total power dissipation TDA8002AT; TDA8002BT TDA8002G	$T_{amb}$ = –25 to +85 °C	–	–	0.56	W
		$T_{amb}$ = –25 to +85 °C	–	–	0.46	W
$T_{amb}$	operating ambient temperature		–25	–	+85	°C

## IC card interface

## TDA8002

**ORDERING INFORMATION**

TYPE NUMBER <sup>(1)</sup>	PACKAGE			
	MARKING	NAME	DESCRIPTION	VERSION
TDA8002AT/3/C2 <sup>(2)</sup>	TDA8002AT/3	SO28	plastic small outline package; 28 leads; body width 7.5 mm	SOT136-1
TDA8002AT/5/C2 <sup>(3)</sup>	TDA8002AT/5			
TDA8002BT/3/C2 <sup>(2)</sup>	TDA8002BT/3			
TDA8002BT/5/C2 <sup>(3)</sup>	TDA8002BT/5			
TDA8002G/3/C2 <sup>(2)</sup>	80023	LQFP32	plastic low profile quad flat package; 32 leads; body 5 × 5 × 1.4 mm	SOT401-1
TDA8002G/5/C2 <sup>(3)</sup>	80025			

**Notes**

1. The /3 or /5 suffix indicates the voltage supervisor option.
2. The /3 version can be used with a 3 or 5 V power supply environment (see Chapter "Functional description").
3. The /5 version can be used with a 5 V power supply environment.

IC card interface

TDA8002

BLOCK DIAGRAM

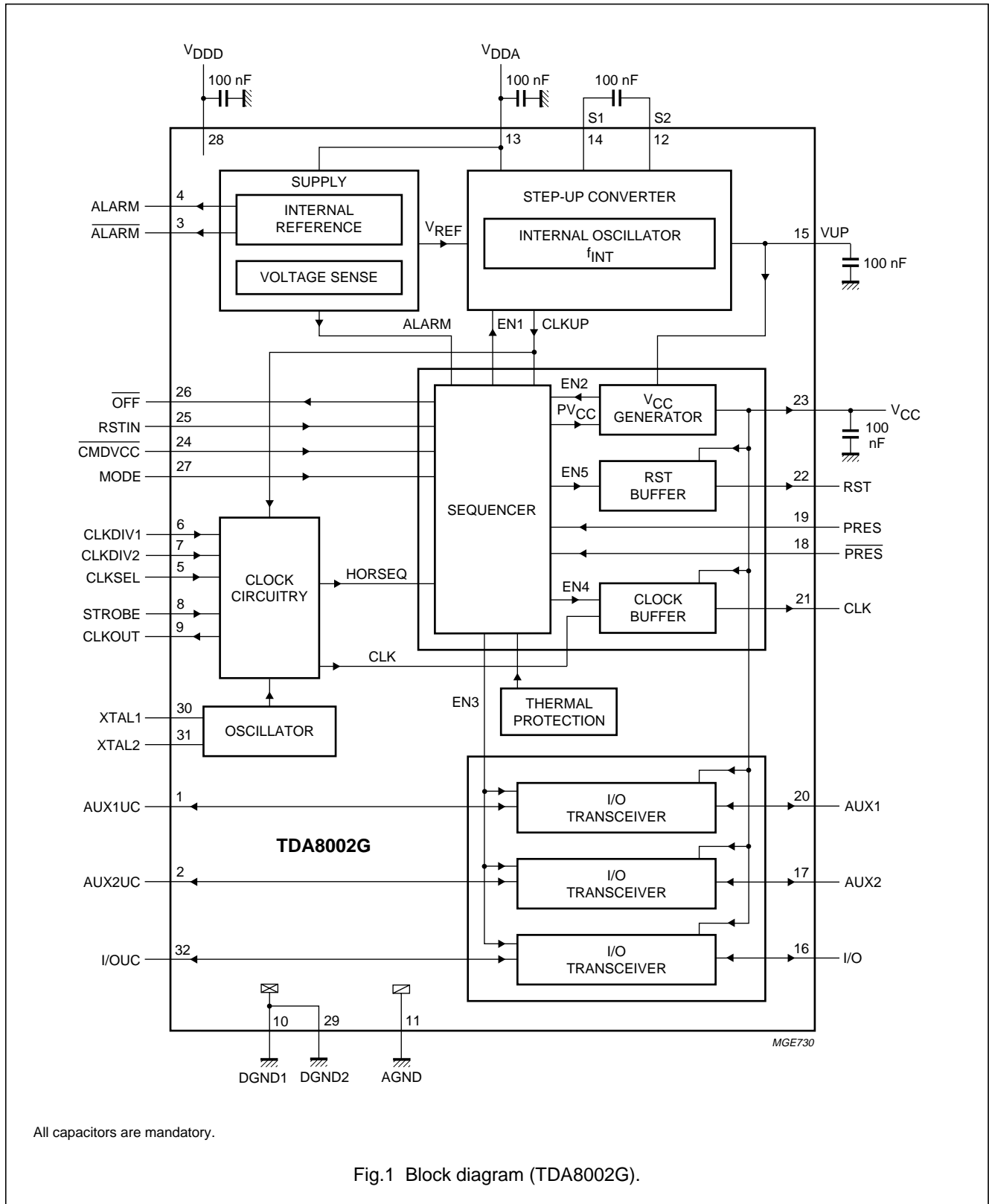

## IC card interface

## TDA8002

## PINNING

SYMBOL	PIN			I/O	DESCRIPTION
	TYPE A	TYPE B	TYPE G		
XTAL1	1	1	30	I/O	crystal connection or input for external clock
XTAL2	2	2	31	I/O	crystal connection
I/OUC	3	3	32	I/O	data I/O line to and from microcontroller
AUX1UC	4	4	1	I/O	auxiliary line to and from microcontroller for synchronous applications
AUX2UC	5	–	2	I/O	auxiliary line to and from microcontroller for synchronous applications
$\overline{\text{ALARM}}$	–	5	3	O	open drain NMOS reset output for microcontroller (active LOW)
ALARM	6	6	4	O	open drain PMOS reset output for microcontroller (active HIGH)
CLKSEL	7	7	5	I	control input signal for CLK (LOW = XTAL oscillator; HIGH = STROBE input)
CLKDIV1	8	8	6	I	control input with CLKDIV2 for choosing CLK frequency
CLKDIV2	9	9	7	I	control input with CLKDIV1 for choosing CLK frequency
STROBE	10	10	8	I	external clock input for synchronous applications
CLKOUT	11	11	9	O	clock output (see Table 1)
DGND1	12	12	10	supply	digital ground 1
AGND	13	13	11	supply	analog ground
S2	14	14	12	I/O	capacitance connection for voltage doubler
V <sub>DDA</sub>	15	15	13	supply	analog supply voltage
S1	16	16	14	I/O	capacitance connection for voltage doubler
VUP	17	17	15	I/O	output of voltage doubler (connect to 100 nF)
I/O	18	18	16	I/O	data I/O line to and from card
AUX2	19	–	17	I/O	auxiliary I/O line to and from card
$\overline{\text{PRES}}$	20	19	18	I	active LOW card input presence contact
PRES	–	20	19	I	active HIGH card input presence contact
AUX1	21	21	20	I/O	auxiliary I/O line to and from card
CLK	22	22	21	O	clock to card output (C3) (see Table 1)
RST	23	23	22	O	card reset output (C2)
V <sub>CC</sub>	24	24	23	O	supply for card (C1) (decouple with 100 nF)
$\overline{\text{CMDVCC}}$	25	25	24	I	active LOW start activation sequence input from microcontroller
RSTIN	26	26	25	I	card reset input from microcontroller
$\overline{\text{OFF}}$	27	27	26	O	open drain NMOS interrupt output to microcontroller (active LOW)
MODE	28	28	27	I	operating mode selection input (HIGH = normal; LOW = sleep)
V <sub>DDD</sub>	–	–	28	supply	digital supply voltage
DGND2	–	–	29	supply	digital ground 2

IC card interface

TDA8002

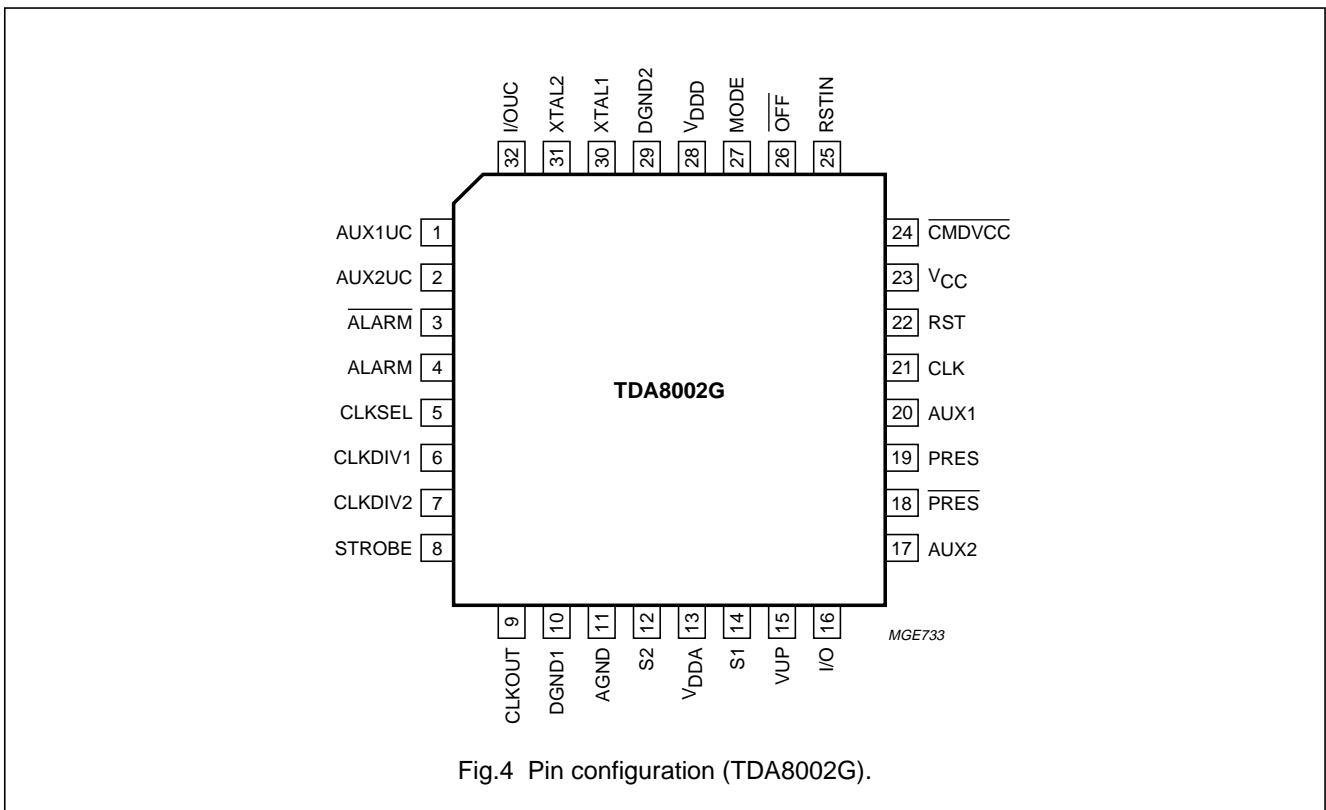
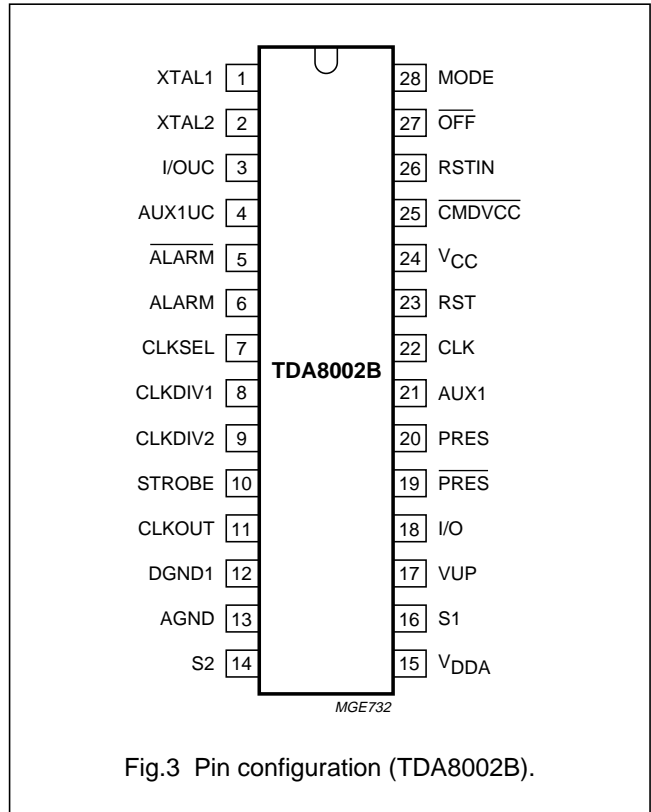
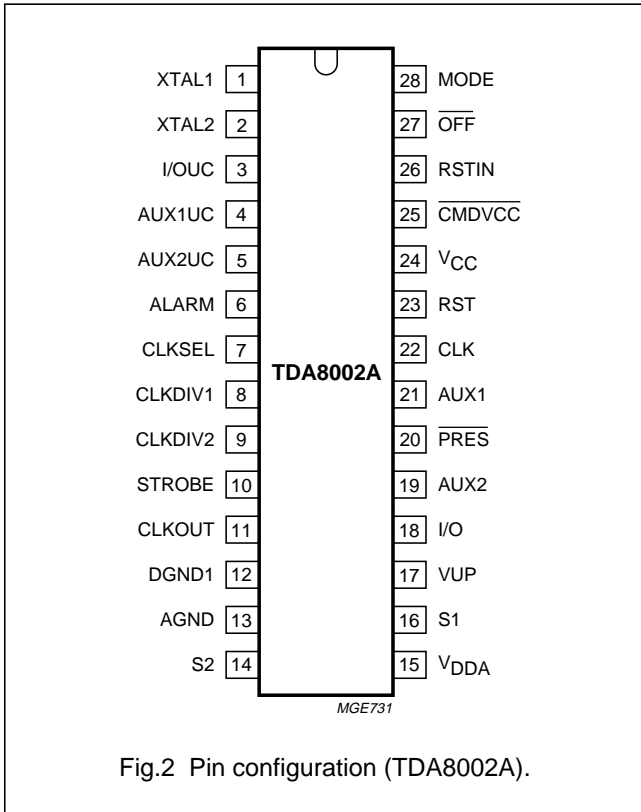

## IC card interface

## TDA8002

## FUNCTIONAL DESCRIPTION

## Power supply

The supply pins for the chip are  $V_{DDA}$ ,  $V_{DDD}$ , AGND, DGND1 and DGND2.  $V_{DDA}$  and  $V_{DDD}$  (i.e.  $V_{DD}$ ) should be in the range of 3.0 to 6.5 V. All card contacts remain inactive during power-up or power-down.

On power-up, the logic is reset by an internal signal. The sequencer is not activated until  $V_{DD}$  reaches  $V_{th2} + V_{hys2}$  (see Fig.5). When  $V_{DD}$  falls below  $V_{th2}$ , an automatic deactivation sequence of the contacts is performed.

Supply voltage supervisor ( $V_{DD}$ )

This block surveys the  $V_{DD}$  supply. A defined reset pulse of 10 ms minimum ( $t_W$ ) can be retrigged and is delivered on the ALARM outputs during power-up or power-down of  $V_{DD}$  (see Fig.5). This signal is also used for eliminating the spikes on card contacts during power-up or power-down.

When  $V_{DD}$  reaches  $V_{th2} + V_{hys2}$ , an internal delay is started. The ALARM outputs are active until this delay has expired. When  $V_{DD}$  falls below  $V_{th2}$ , ALARM is activated and a deactivation sequence of the contacts is performed.

For 3 V supply, the supervisor option must be chosen at 3 V. For 5 V supply, both options (3 or 5 V) may be chosen depending on the application.

## Clock circuitry

The TDA8002 supports both synchronous and asynchronous cards (I<sup>2</sup>C-bus memories requiring an acknowledge signal from the master are not supported). There are three methods to clock the circuitry:

- Apply a clock signal to pin STROBE
- Use of an internal RC oscillator
- Use of a quartz oscillator which should be connected between pins XTAL1 and XTAL2.

When CLKSEL is HIGH, the clock should be applied on the STROBE pin, and when CLKSEL is LOW, one of the internal oscillators is used.

When an internal clock is used, the clock output is available on pin CLKOUT. The RC oscillator is selected by making CLKDIV1 HIGH and CLKDIV2 LOW. The clock output to the card is available on pin CLK. The frequency of the card clock can be the input frequency divided by 2 or 4, STOP LOW or 1.25 MHz, depending on the states of CLKDIV1 or CLKDIV2 (see Table 1).

Do not change CLKSEL during activation. When in low-power (sleep) mode, the internal oscillator frequency which is available on pin CLKOUT is lowered to approximately 16 kHz for power-economy purposes.

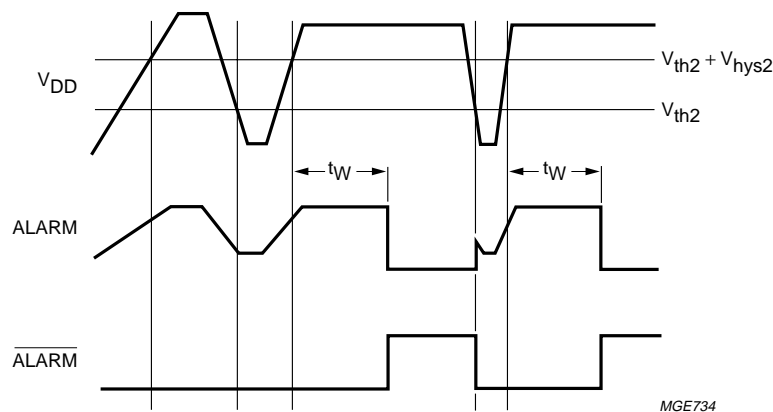

Fig.5 Alarm as a function of  $V_{DD}$  (pulse width 10 ms).

IC card interface

TDA8002

**Table 1** Clock circuitry definition

MODE	CLKSEL	CLKDIV1	CLKDIV2	FREQUENCY OF CLK	FREQUENCY OF CLKOUT
HIGH	LOW	HIGH	LOW	$\frac{1}{2}f_{int}$	$\frac{1}{2}f_{int}$
HIGH	LOW	LOW	LOW	$\frac{1}{4}f_{xtal}$	$f_{xtal}$
HIGH	LOW	LOW	HIGH	$\frac{1}{2}f_{xtal}$	$f_{xtal}$
HIGH	LOW	HIGH	HIGH	STOP LOW	$f_{xtal}$
HIGH	HIGH	X <sup>(1)</sup>	X <sup>(1)</sup>	STROBE	$f_{xtal}$
LOW <sup>(2)</sup>	X <sup>(1)</sup>	X <sup>(1)</sup>	X <sup>(1)</sup>	STOP LOW	$\frac{1}{2}f_{int}$ <sup>(3)</sup>

**Notes**

1. X = don't care.
2. In low-power mode.
3.  $f_{int}$  = 32 kHz in low-power mode.

**I/O circuitry**

The three I/O transceivers are identical. The state is HIGH for all I/O pins (i.e. I/O, I/OUC, AUX1, AUX1UC, AUX2 and AUX2UC). Pin I/O is referenced to  $V_{CC}$  and pin I/OUC to  $V_{DD}$ , thus ensuring proper operation in case  $V_{CC} \neq V_{DD}$ .

The first side on which a falling edge is detected becomes a master (input). An anti-latch circuitry first disables the detection of the falling edge on the other side, which becomes slave (output).

After a delay time  $t_d$  (about 50 ns), the logic 0 present on the master side is transferred on the slave side.

When the input is back to HIGH level, a current booster is turned on during the delay  $t_d$  on the output side and then both sides are back to their idle state, ready to detect the next logic 0 on any side.

In case of a conflict, both lines may remain LOW until the software enables the lines to be HIGH. The anti-latch circuitry ensures that the lines do not remain LOW if both sides return HIGH, regardless of the prior conditions. The maximum frequency on the lines is approximately 1 MHz.

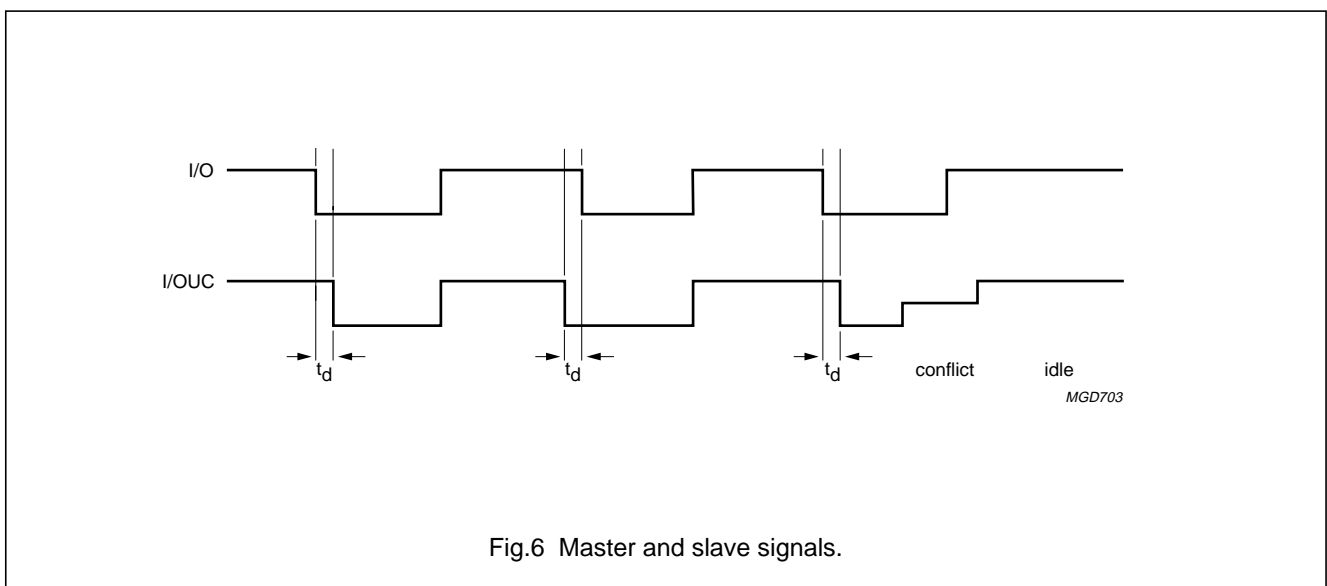

Fig.6 Master and slave signals.



IC card interface

TDA8002

**Logic circuitry**

After power-up, the circuit has six possible states of operation. Table 1 shows the sequence of these states.

**IDLE MODE**

After reset, the circuit enters the idle mode. A minimum number of functions in the circuit are active while waiting for the microcontroller to start a session:

- All card contacts are inactive
- I/OUC, AUX1UC and AUX2UC are high-impedance
- Oscillator XTAL runs, delivering CLKOUT
- Voltage supervisor is active.

**LOW-POWER (SLEEP) MODE**

When pin MODE goes LOW, the circuit enters the low-power (sleep) mode. As long as pin MODE is LOW, no activation is possible.

If pin MODE goes LOW in the active mode, a normal deactivation sequence is performed before entering low-power mode. When pin MODE goes HIGH, the circuit enters normal operation after a delay of at least 6 ms (96 cycles of CLKOUT). During this time the CLKOUT remains at 16 kHz.

- All card contacts are inactive
- Oscillator XTAL does not run
- The V<sub>DD</sub> supervisor, ALARM output, card presence detection and  $\overline{\text{OFF}}$  output remain functional
- Internal oscillator is slowed to 32 kHz, CLKOUT providing 16 kHz.

**ACTIVE MODE**

When the activation sequence is completed, the TDA8002 will be in the active mode. Data is exchanged between the card and the microcontroller via the I/O lines.

**State diagram**

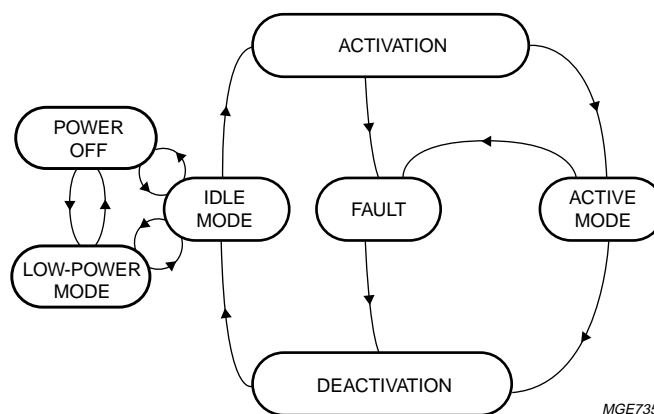

Fig.7 State diagram.

IC card interface

TDA8002

ACTIVATION SEQUENCE

From idle mode, the circuit enters the activation mode when the microcontroller sets the  $\overline{\text{CMDVCC}}$  line LOW or sets the MODE line HIGH when the  $\text{CMDVCC}$  line is already LOW. The internal circuitry is then activated, the internal clock is activated and an activation sequence is executed. When RST is enabled, it becomes the inverse of RSTIN.

Figures 8 to 10 illustrate the activation sequence as described below:

1. Step-up converter is started ( $t_1 \approx t_0$ )
2.  $V_{CC}$  rises from 0 to 5 V ( $t_2 = t_1 + 1\frac{1}{2}T$ )
3. I/O, AUX1, AUX2 are enabled and CLK is enabled ( $t_3 = t_1 + 4T$ ); a special circuitry ensures that I/O remains below  $V_{CC}$  during falling slope of  $V_{CC}$
4. CLK is set by setting RSTIN to HIGH ( $t_4$ )
5. RST is enabled ( $t_5 = t_1 + 7T$ ); after  $t_5$ , RSTIN has no further action on CLK, but is only controlling RST.

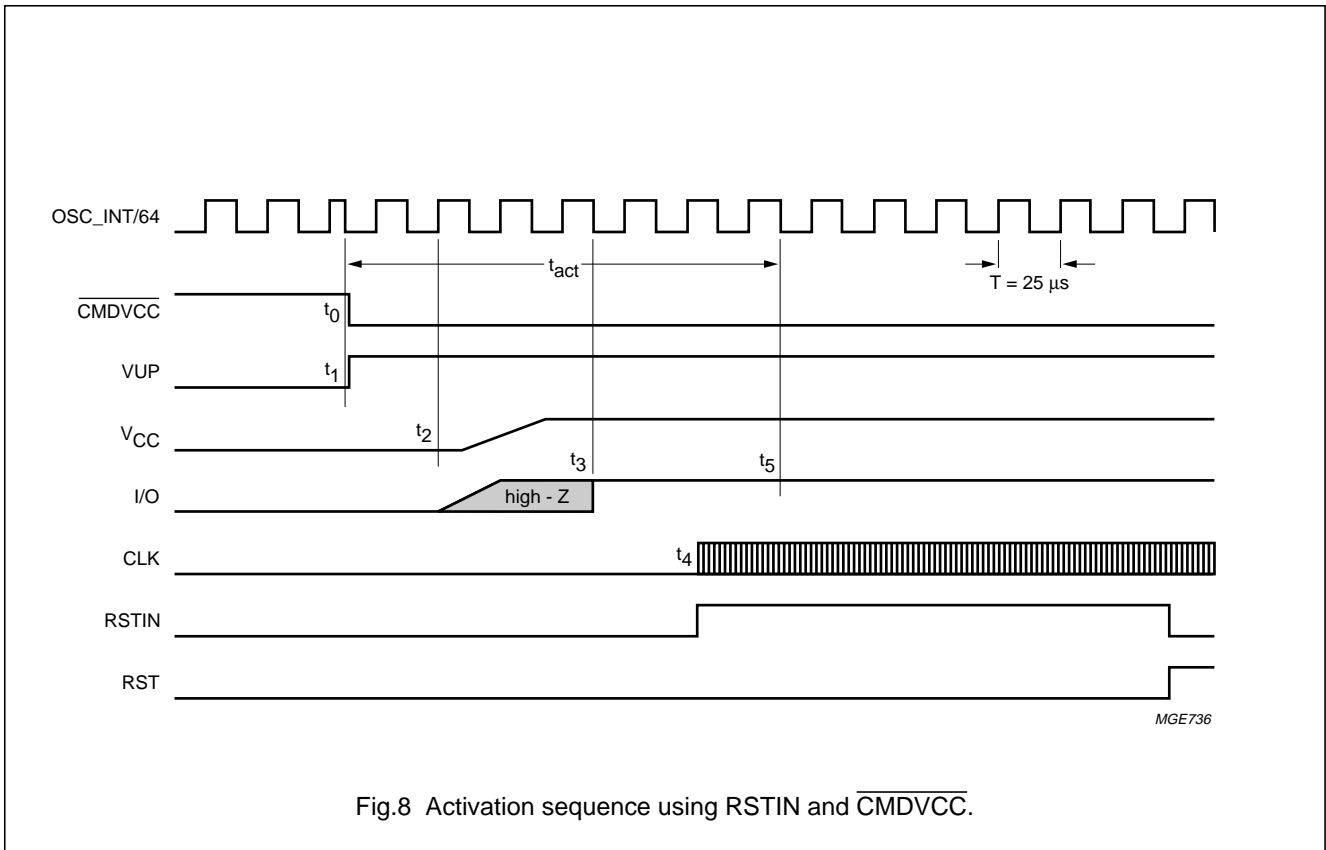

IC card interface

TDA8002

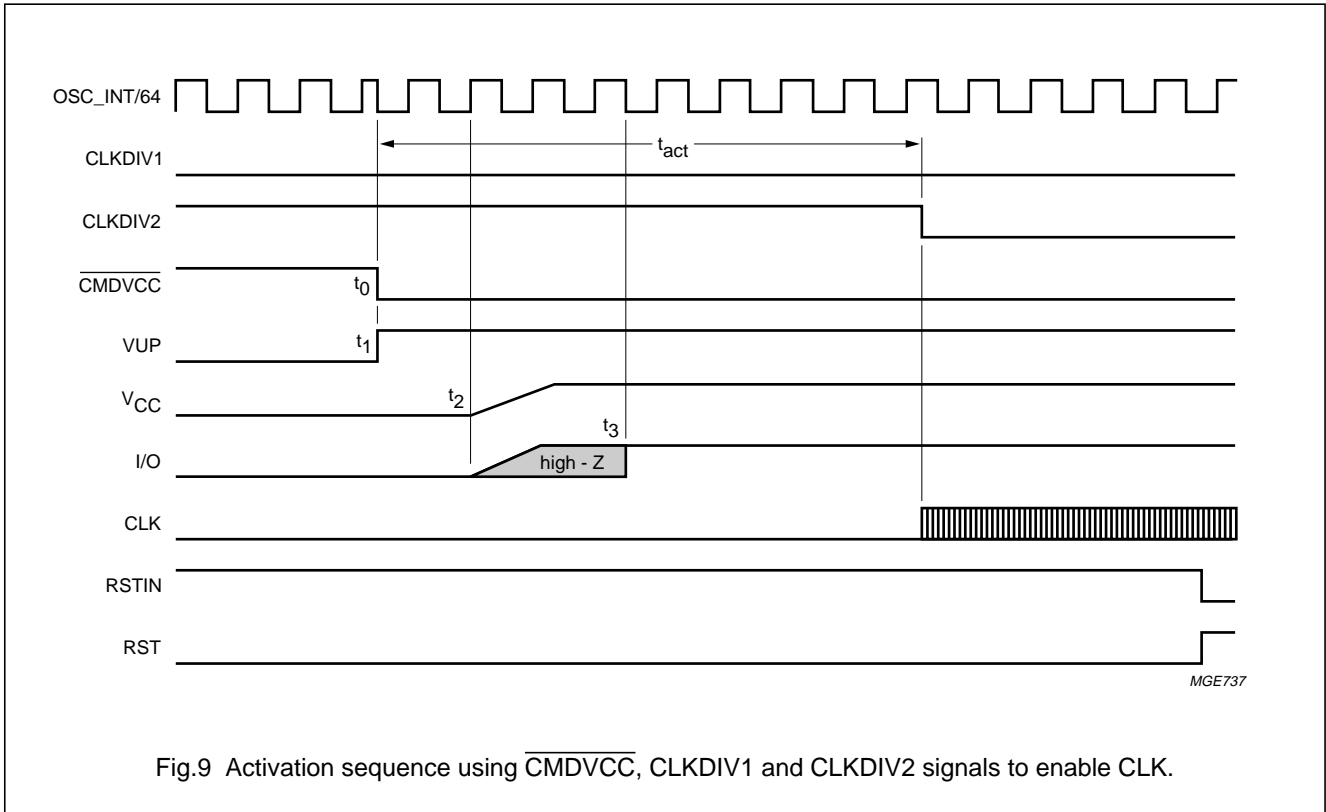

Fig.9 Activation sequence using  $\overline{\text{CMDVCC}}$ , CLKDIV1 and CLKDIV2 signals to enable CLK.

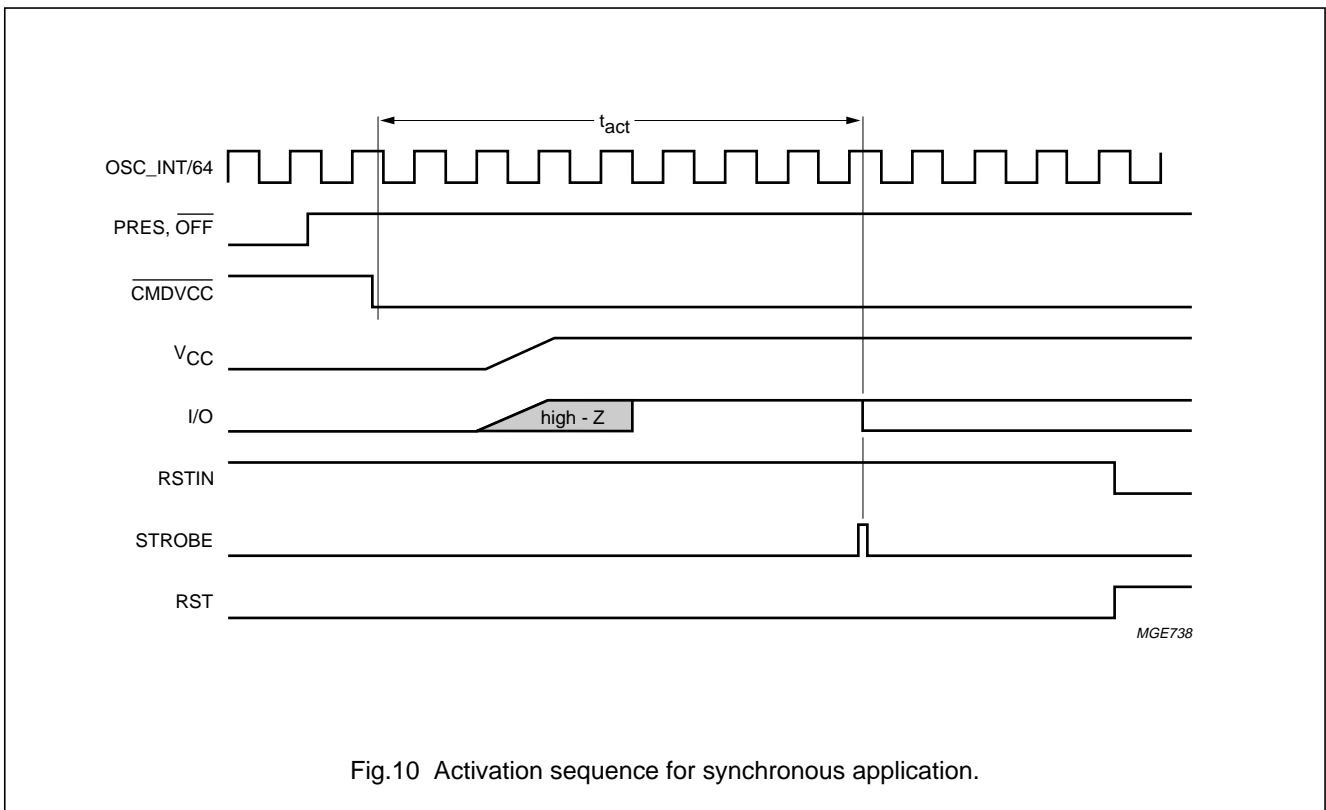

Fig.10 Activation sequence for synchronous application.

IC card interface

TDA8002

DEACTIVATION SEQUENCE

When a session is completed, the microcontroller sets the  $\overline{\text{CMDVCC}}$  line to HIGH state or MODE line to LOW state. The circuit then executes an automatic deactivation sequence by counting the sequencer down and ends in idle mode.

Figures 11 and 12 illustrate the deactivation sequence as described below:

1. RST goes LOW ( $t_{11} \approx t_{10}$ )
2. CLK is stopped ( $t_{12} = t_{11} + \frac{1}{2}T$ )
3. I/O, AUX1, AUX2 are outputs into high-impedance state ( $t_{13} = t_{11} + T$ )
4.  $V_{CC}$  falls to zero ( $t_{14} = t_{11} + 1\frac{1}{2}T$ ); a special circuitry ensures that I/O remains below  $V_{CC}$  during falling slope of  $V_{CC}$
5. VUP falls ( $t_{15} = t_{11} + 5T$ ).

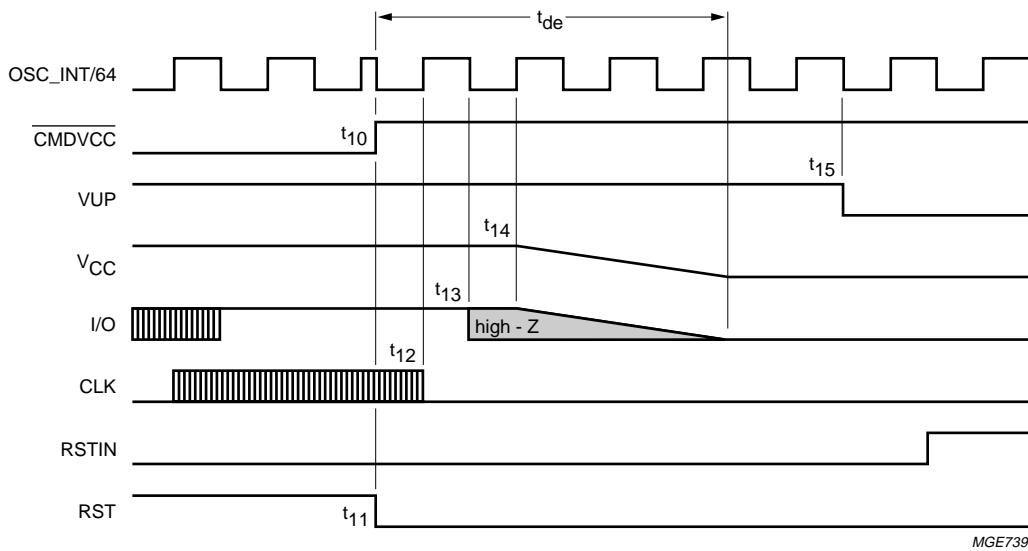

Fig.11 Deactivation sequence.

IC card interface

TDA8002

**Fault detection**

The following fault conditions are monitored by the circuit:

- Short-circuit or high current on  $V_{CC}$
- Removing card during transaction
- $V_{DD}$  dropping
- Overheating.

When one or more of these faults are detected, the circuit pulls the interrupt line  $\overline{OFF}$  to its active LOW state and a deactivation sequence is initiated. In case the card is present the interrupt line  $\overline{OFF}$  is set to HIGH when the microcontroller has reset the  $\overline{CMDVCC}$  line HIGH (after completion of the deactivation sequence). In case the card is not present  $\overline{OFF}$  remains LOW.

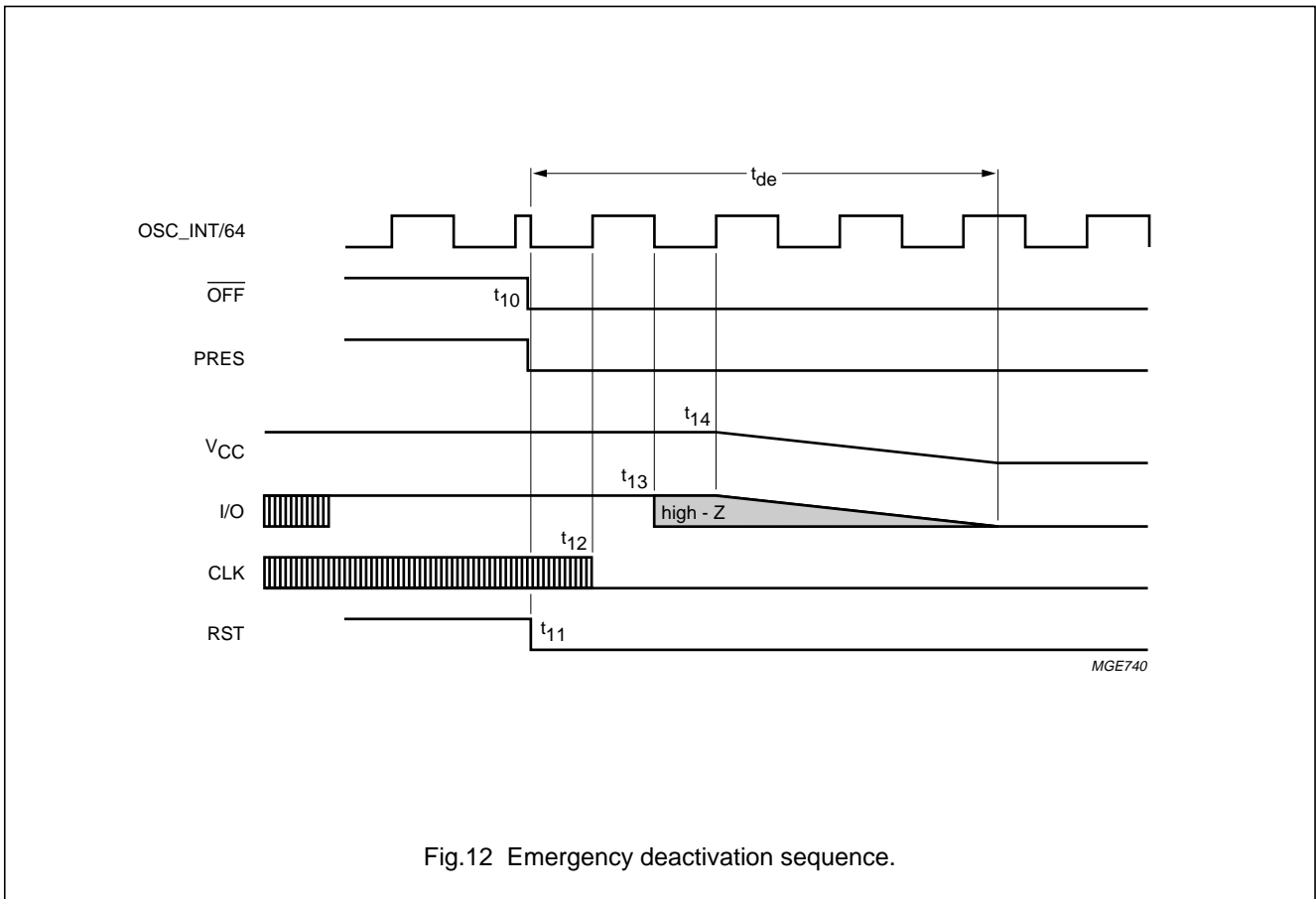

Fig.12 Emergency deactivation sequence.

## IC card interface

## TDA8002

**LIMITING VALUES**

In accordance with the Absolute Maximum Rating System (IEC 134); note 1.

SYMBOL	PARAMETER	CONDITIONS	MIN.	MAX.	UNIT
$V_{DD}$	supply voltage		-0.3	+6.5	V
$V_{i(CMOS)}$	voltage on CMOS pins XTAL1, XTAL2, ALARM, $\overline{ALARM}$ , MODE, RSTIN, CLKSEL, AUX2UC, AUX1UC, CLKDIV1, CLKDIV2, CLKOUT, STROBE, $\overline{CMDVCC}$ and $\overline{OFF}$		-0.3	+6.5	V
$V_{i(card)}$	voltage on card contact pins I/O, AUX2, $\overline{PRES}$ , PRES, AUX1, CLK, RST and $V_{CC}$		-0.3	+6.5	V
$V_{es}$	electrostatic handling on pins I/O, RST, $\overline{V_{CC}}$ , CLK, AUX1, AUX2, PRES and $\overline{PRES}$ on all other pins		-6	+6	kV
			-2	+2	kV
$T_{stg}$	storage temperature		-55	+125	°C
$P_{tot}$	continuous total power dissipation TDA8002T TDA8002G	$T_{amb} = -25$ to $+85$ °C	-	0.56	W
		$T_{amb} = -25$ to $+85$ °C	-	0.46	W
$T_{amb}$	operating ambient temperature		-25	+85	°C
$T_j$	junction temperature		-	150	°C

**Note**

1. Stress beyond these levels may cause permanent damage to the device. This is a stress rating only and functional operation of the device under this condition is not implied.

**HANDLING**

Every pin withstands the ESD test according to MIL-STD-883C class 3 for card contacts, class 2 for the remaining. Method 3015 (HBM 1500  $\Omega$ , 100 pF) 3 positive pulses and 3 negative pulses on each pin referenced to ground.

**THERMAL CHARACTERISTICS**

SYMBOL	PARAMETER	VALUE	UNIT
$R_{th(j-a)}$	thermal resistance from junction to ambient in free air		
	SOT136-1	70	K/W
	SOT401-1	91	K/W

## IC card interface

## TDA8002

## CHARACTERISTICS

$V_{DD} = 5\text{ V}$ ;  $T_{amb} = 25\text{ }^{\circ}\text{C}$ ;  $f_{xtal} = 10\text{ MHz}$ ; unless otherwise specified.

SYMBOL	PARAMETER	CONDITIONS	MIN.	TYP.	MAX.	UNIT
<b>Supply</b>						
$V_{DD}$	positive supply voltage	option 5 V power supply (TDA8002xx/5)	4.5	5	6.5	V
		option 3.3 V or 5 V power supply (TDA8002xx/3)	3	5	6.5	V
$I_{DD(s)}$	supply current	sleep mode; $V_{DD} = 5\text{ V}$	–	–	200	$\mu\text{A}$
$I_{DD(idle)}$	supply current	idle mode; $V_{DD} = 5\text{ V}$ ; $f_{CLK} = 2.5\text{ MHz}$ ; $f_{CLKOUT} = 10\text{ MHz}$	–	–	6	mA
$I_{DD(active)}$	supply current	active mode $V_{DD} = 5\text{ V}$ ; $f_{CLK} = 2.5\text{ MHz}$ ; $f_{CLKOUT} = 10\text{ MHz}$	–	–	9	mA
		$V_{DD} = 3.3\text{ V}$ ; $f_{CLK} = 2.5\text{ MHz}$ ; $f_{CLKOUT} = 10\text{ MHz}$	–	–	12	mA
$V_{th2}$	threshold voltage on $V_{DD}$ for voltage supervisor	falling option 5 V power supply (TDA8002xx/5)	3.9	4.05	4.2	V
		option 3.3 V or 5 V power supply (TDA8002xx/3)	2.6	2.7	2.8	V
		rising option 5 V power supply (TDA8002xx/5)	4	4.2	4.4	V
		option 3.3 or 5 V power supply (TDA8002xx/3)	2.7	2.85	2.99	V
$V_{hys2}$	hysteresis on $V_{th2}$		100	150	200	mV
<b>CARD SUPPLY</b>						
$V_{CC(O)(idle)}$	output voltage	idle mode	–	–	0.4	V
$V_{CC(O)(active)}$	output voltage	active mode $I_{CC} < 20\text{ mA}$ : DC load with $3\text{ V} < V_{DD} < 3.3\text{ V}$	4.75	–	5.25	V
		$I_{CC} < 65\text{ mA}$ : DC load with $3.3\text{ V} < V_{DD} < 6.5\text{ V}$	4.75	–	5.25	V
		$I_{CC} = 40\text{ mA}$ : AC load	4.6	–	5.4	V
$I_{CC(O)}$	output current	$V_{CC(O)} = \text{from } 0\text{ to } 5\text{ V}$	–	–	65	mA
		$V_{CC}$ short-circuited to ground	–	–	100	mA
SR	slew rate	rising or falling slope	0.12	0.17	0.22	V/ $\mu\text{s}$

## IC card interface

## TDA8002

SYMBOL	PARAMETER	CONDITIONS	MIN.	TYP.	MAX.	UNIT
<b>Crystal connections (XTAL1 and XTAL2)</b>						
$C_{\text{ext}}$	external capacitors	note 1	–	15	–	pF
$f_{\text{xtal}}$	resonance frequency	note 2	2	–	24	MHz
<b>Data lines</b>						
GENERAL						
$t_{\text{edge}}$	delay between falling edge of I/O, AUX1, AUX2 and I/OUC, AUX1UC, AUX2UC		–	200	–	ns
	delay between falling edge of I/OUC, AUX1UC, AUX2UC and I/O, AUX1, AUX2		–	200	–	ns
$t_r, t_f$	rise and fall times	$C_i = C_o = 30 \text{ pF}$	–	–	0.5	$\mu\text{s}$
DATA LINES I/O, AUX1 AND AUX2						
$V_{\text{OH(I/O)}}$	HIGH-level output voltage on data lines	$I_{\text{OH}} = -20 \mu\text{A}$	$V_{\text{CC}} - 0.5$	–	$V_{\text{CC}} + 0.1$	V
		$I_{\text{OH}} = -100 \mu\text{A}$	3.5	–	–	V
$V_{\text{OL(I/O)}}$	LOW-level output voltage on data lines	$I_{\text{I/O}} = 1 \text{ mA}$	–	–	300	mV
$V_{\text{IH(I/O)}}$	HIGH-level input voltage on data lines		1.8	–	$V_{\text{CC}}$	V
$V_{\text{IL(I/O)}}$	LOW-level input voltage on data lines		0	–	0.8	V
$V_{\text{I/O(idle)}}$	voltage on data lines outside a session		–	–	0.4	V
$R_{\text{pu}}$	internal pull-up resistance between data lines and $V_{\text{CC}}$		8	10	12	$\text{k}\Omega$
$I_{\text{edge}}$	current from data lines when active pull-up is active		–	1	–	mA
$I_{\text{IL(I/O)}}$	LOW-level input current on data lines	$V_{\text{IL}} = 0.4 \text{ V}$	–	–	–600	$\mu\text{A}$
$I_{\text{IH(I/O)}}$	HIGH-level input current on data lines	$V_{\text{IH}} = V_{\text{CC}}$	–	–	10	$\mu\text{A}$
DATA LINES I/OUC, AUX1UC AND AUX2UC						
$V_{\text{OH(I/OUC)}}$	HIGH-level output voltage on data lines	$I_{\text{OH}} = -20 \mu\text{A}$	$V_{\text{DD}} - 1$	–	$V_{\text{DD}} + 0.2$	V
$V_{\text{OL(I/OUC)}}$	LOW-level output voltage on data lines	$I_{\text{I/OUC}} = 1 \text{ mA}$	–	–	300	mV
$V_{\text{IH(I/OUC)}}$	HIGH-level input voltage on data lines		$0.7V_{\text{DD}}$	–	$V_{\text{DD}}$	V
$V_{\text{IL(I/OUC)}}$	LOW-level input voltage on data lines		0	–	$0.3V_{\text{DD}}$	V
$Z_{\text{I/OUC(idle)}}$	impedance on data lines outside a session		10	–	–	$\text{M}\Omega$



## IC card interface

## TDA8002

SYMBOL	PARAMETER	CONDITIONS	MIN.	TYP.	MAX.	UNIT
<b>ALARM, <math>\overline{\text{ALARM}}</math> and <math>\overline{\text{OFF}}</math> when connected (open-drain outputs)</b>						
$I_{\text{OH}}(\overline{\text{ALARM}})$	HIGH-level output current on pin $\overline{\text{ALARM}}$	$V_{\text{OH}}(\overline{\text{ALARM}}) = 5 \text{ V}$	–	–	5	$\mu\text{A}$
$V_{\text{OL}}(\overline{\text{ALARM}})$	LOW-level output voltage on pin $\overline{\text{ALARM}}$	$I_{\text{OL}}(\overline{\text{ALARM}}) = 2 \text{ mA}$	–	–	0.4	V
$I_{\text{OH}}(\overline{\text{OFF}})$	HIGH-level output current on pin $\overline{\text{OFF}}$	$V_{\text{OH}}(\overline{\text{OFF}}) = 5 \text{ V}$	–	–	5	$\mu\text{A}$
$V_{\text{OL}}(\overline{\text{OFF}})$	LOW-level output voltage on pin $\overline{\text{OFF}}$	$I_{\text{OL}}(\overline{\text{OFF}}) = 2 \text{ mA}$	–	–	0.4	V
$I_{\text{OL}}(\text{ALARM})$	LOW-level output current on pin ALARM	$V_{\text{OL}}(\text{ALARM}) = 0 \text{ V}$	–	–	–5	$\mu\text{A}$
$V_{\text{OH}}(\text{ALARM})$	HIGH-level output voltage on pin ALARM	$I_{\text{OH}}(\text{ALARM}) = -2 \text{ mA}$	$V_{\text{DD}} - 1$	–	–	V
$t_{\text{W}}$	ALARM pulse width		6	–	20	ms
<b>Clock output (CLKOUT; powered from <math>V_{\text{DD}}</math>)</b>						
$f_{\text{CLKOUT}}$	frequency on CLKOUT		0	–	20	MHz
		low power	–	16	–	kHz
$V_{\text{OL}}$	LOW-level output voltage	$I_{\text{OL}} = 1 \text{ mA}$	0	–	0.5	V
$V_{\text{OH}}$	HIGH-level output voltage	$I_{\text{OH}} = -1 \text{ mA}$	$V_{\text{DD}} - 0.5$	–	–	V
$t_{\text{r}}, t_{\text{f}}$	rise and fall times	$C_{\text{L}} = 15 \text{ pF}$ ; notes 3 and 5	–	–	8	ns
$\delta$	duty factor	$C_{\text{L}} = 15 \text{ pF}$ ; notes 3 and 5	40	–	60	%
<b>Internal oscillator</b>						
$f_{\text{int}}$	frequency of internal oscillator	active mode	2.2	2.7	3.2	MHz
		sleep mode	–	32	–	kHz
<b>Card reset output (RST)</b>						
$V_{\text{O}}(\text{inact})$	output voltage	inactive modes	0	–	0.3	V
$t_{\text{d}}(\text{RST})$	delay between RSTIN and RST	RST enabled	–	–	100	ns
$V_{\text{OL}}$	LOW-level output voltage	$I_{\text{OL}} = 200 \mu\text{A}$	0	–	0.3	V
$V_{\text{OH}}$	HIGH-level output voltage	$I_{\text{OH}} = -200 \mu\text{A}$	4.3	–	$V_{\text{CC}}$	V
		$I_{\text{OH}} = -50 \mu\text{A}$	$V_{\text{CC}} - 0.5$	–	$V_{\text{CC}}$	V
<b>Card clock output (CLK)</b>						
$V_{\text{O}}(\text{inact})$	output voltage	inactive modes	0	–	0.3	V
$V_{\text{OL}}$	LOW-level output voltage	$I_{\text{OL}} = 200 \mu\text{A}$	0	–	0.3	V
$V_{\text{OH}}$	HIGH-level output voltage	$I_{\text{OH}} = -50 \mu\text{A}$	$V_{\text{CC}} - 0.5$	–	$V_{\text{CC}}$	V
$t_{\text{r}}$	rise time	$C_{\text{L}} = 30 \text{ pF}$ ; note 3	–	–	8	ns
$t_{\text{f}}$	fall time	$C_{\text{L}} = 30 \text{ pF}$ ; note 3	–	–	8	ns
$\delta$	duty factor	$C_{\text{L}} = 30 \text{ pF}$ ; note 3	45	–	55	%
SR	slew rate (rise and fall)		0.2	–	–	V/ns

## IC card interface

## TDA8002

SYMBOL	PARAMETER	CONDITIONS	MIN.	TYP.	MAX.	UNIT
<b>Strobe input (STROBE)</b>						
f <sub>STROBE</sub>	frequency on STROBE		0	–	20	MHz
V <sub>IL</sub>	LOW-level input voltage		0	–	0.3V <sub>DD</sub>	V
V <sub>IH</sub>	HIGH-level input voltage		0.7V <sub>DD</sub>	–	V <sub>DD</sub>	V
<b>Logic inputs (CLKSEL, CLKDIV1, CLKDIV2, MODE, <math>\overline{\text{CMDVCC}}</math> and RSTIN); note 4</b>						
V <sub>IL</sub>	LOW-level input voltage		0	–	0.8	V
V <sub>IH</sub>	HIGH-level input voltage		1.8	–	V <sub>DD</sub>	V
<b>Logic inputs (PRES, <math>\overline{\text{PRES}}</math>); note 4</b>						
V <sub>IL</sub>	LOW-level input voltage		0	–	0.3V <sub>DD</sub>	V
V <sub>IH</sub>	HIGH-level input voltage		0.7V <sub>DD</sub>	–	V <sub>DD</sub>	V
I <sub>IL(PRES)</sub>	LOW-level input current on pin PRES	V <sub>OL</sub> = 0 V	–	–	–10	μA
I <sub>IH(PRES)</sub>	HIGH-level input current on pin PRES		–	–	10	μA
<b>Protections</b>						
T <sub>sd</sub>	shut-down local temperature		–	135	–	°C
I <sub>CC(sd)</sub>	shut-down current at V <sub>CC</sub>		–	–	90	mA
<b>Timing</b>						
t <sub>act</sub>	activation sequence duration	see Fig.9; guaranteed by design	–	180	220	μs
t <sub>de</sub>	deactivation sequence duration	see Fig.11; guaranteed by design	50	70	90	μs
t <sub>3</sub>	start of the window for sending CLK to the card	see Figs 8 and 9	–	–	130	μs
t <sub>5</sub>	end of the window for sending CLK to the card	see Fig.8	150	–	–	μs

**Notes**

- It may be necessary to put capacitors from XTAL1 and XTAL2 to ground depending on the choice of crystal or resonator.
- When the oscillator is stopped in mode 1, XTAL1 is set to HIGH.
- The transition time and duty cycle definitions are shown in Fig.13;  $\delta = \frac{t_1}{t_1 + t_2}$
- $\overline{\text{PRES}}$  and  $\overline{\text{CMDVCC}}$  are active LOW; RSTIN and PRES are active HIGH.
- CLKOUT transition time and duty cycle do not need to be tested.

IC card interface

TDA8002

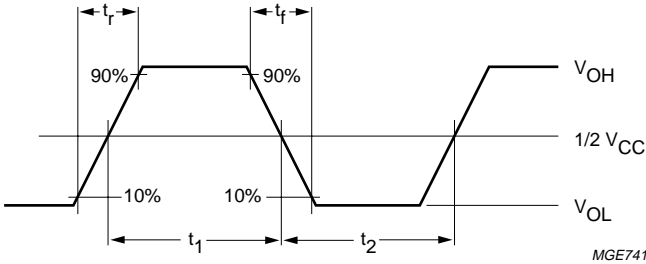

Fig.13 Definition of transition times.

IC card interface

TDA8002

APPLICATION INFORMATION

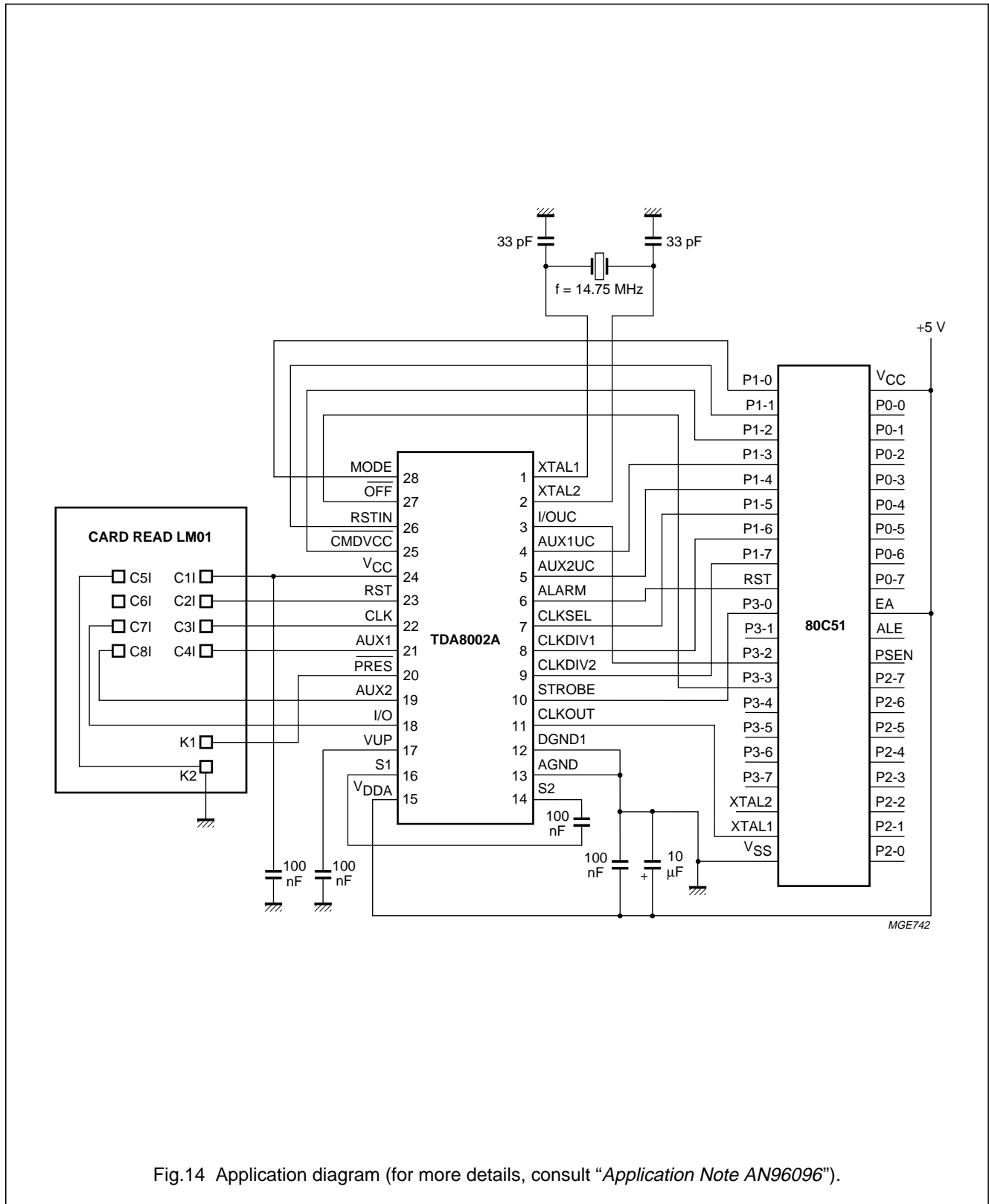

Fig.14 Application diagram (for more details, consult "Application Note AN96096").

IC card interface

TDA8002

PACKAGE OUTLINES

SO28: plastic small outline package; 28 leads; body width 7.5 mm

SOT136-1

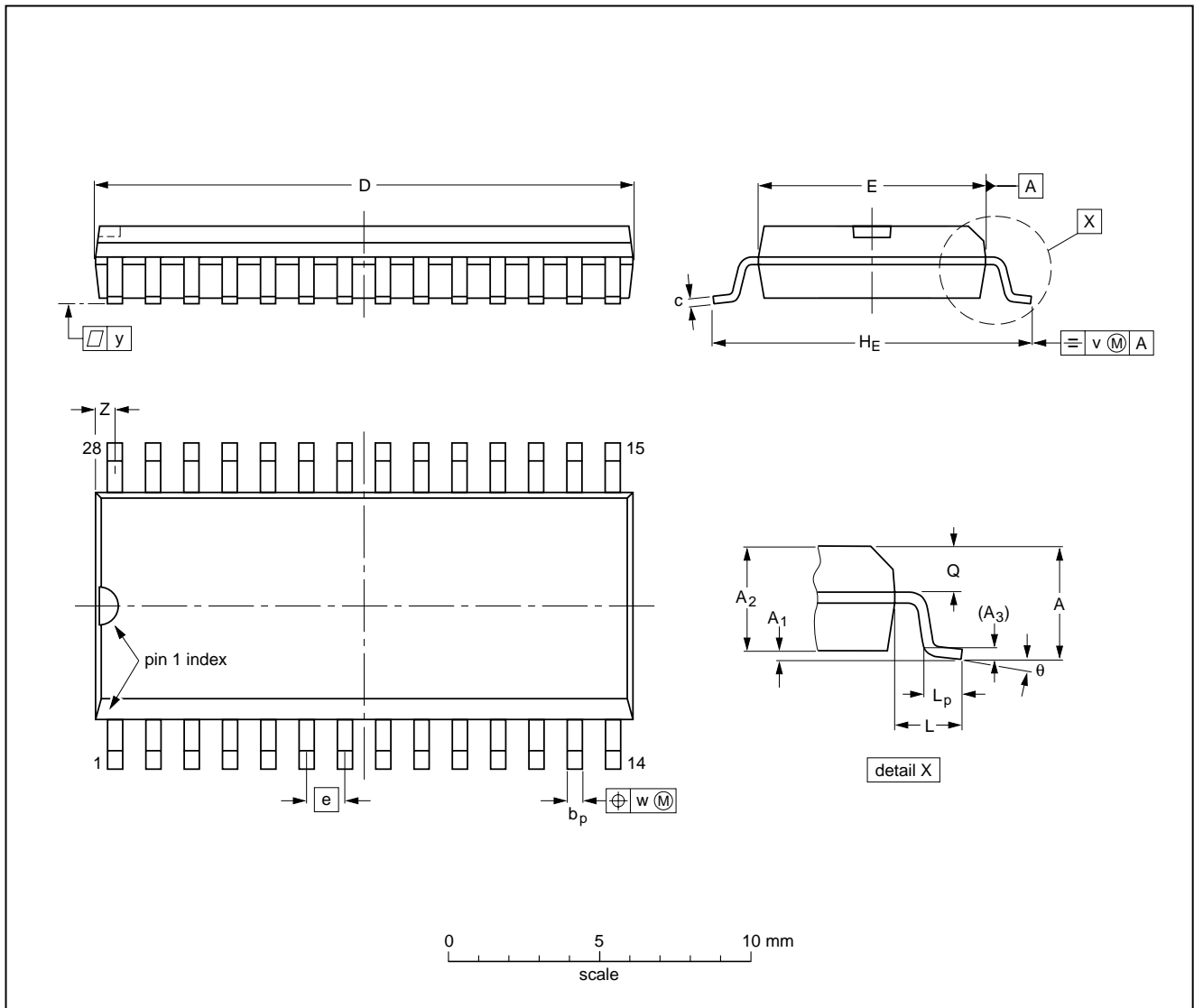

DIMENSIONS (inch dimensions are derived from the original mm dimensions)

UNIT	A max.	A <sub>1</sub>	A <sub>2</sub>	A <sub>3</sub>	b <sub>p</sub>	c	D <sup>(1)</sup>	E <sup>(1)</sup>	e	H <sub>E</sub>	L	L <sub>p</sub>	Q	v	w	y	z <sup>(1)</sup>	θ
mm	2.65	0.30 0.10	2.45 2.25	0.25	0.49 0.36	0.32 0.23	18.1 17.7	7.6 7.4	1.27	10.65 10.00	1.4	1.1 0.4	1.1 1.0	0.25	0.25	0.1	0.9 0.4	8° 0°
inches	0.10	0.012 0.004	0.096 0.089	0.01	0.019 0.014	0.013 0.009	0.71 0.69	0.30 0.29	0.050	0.419 0.394	0.055	0.043 0.016	0.043 0.039	0.01	0.01	0.004	0.035 0.016	

Note

1. Plastic or metal protrusions of 0.15 mm maximum per side are not included.

OUTLINE VERSION	REFERENCES			EUROPEAN PROJECTION	ISSUE DATE
	IEC	JEDEC	EIAJ		
SOT136-1	075E06	MS-013AE			95-01-24 97-05-22

IC card interface

TDA8002

LQFP32: plastic low profile quad flat package; 32 leads; body 5 x 5 x 1.4 mm

SOT401-1

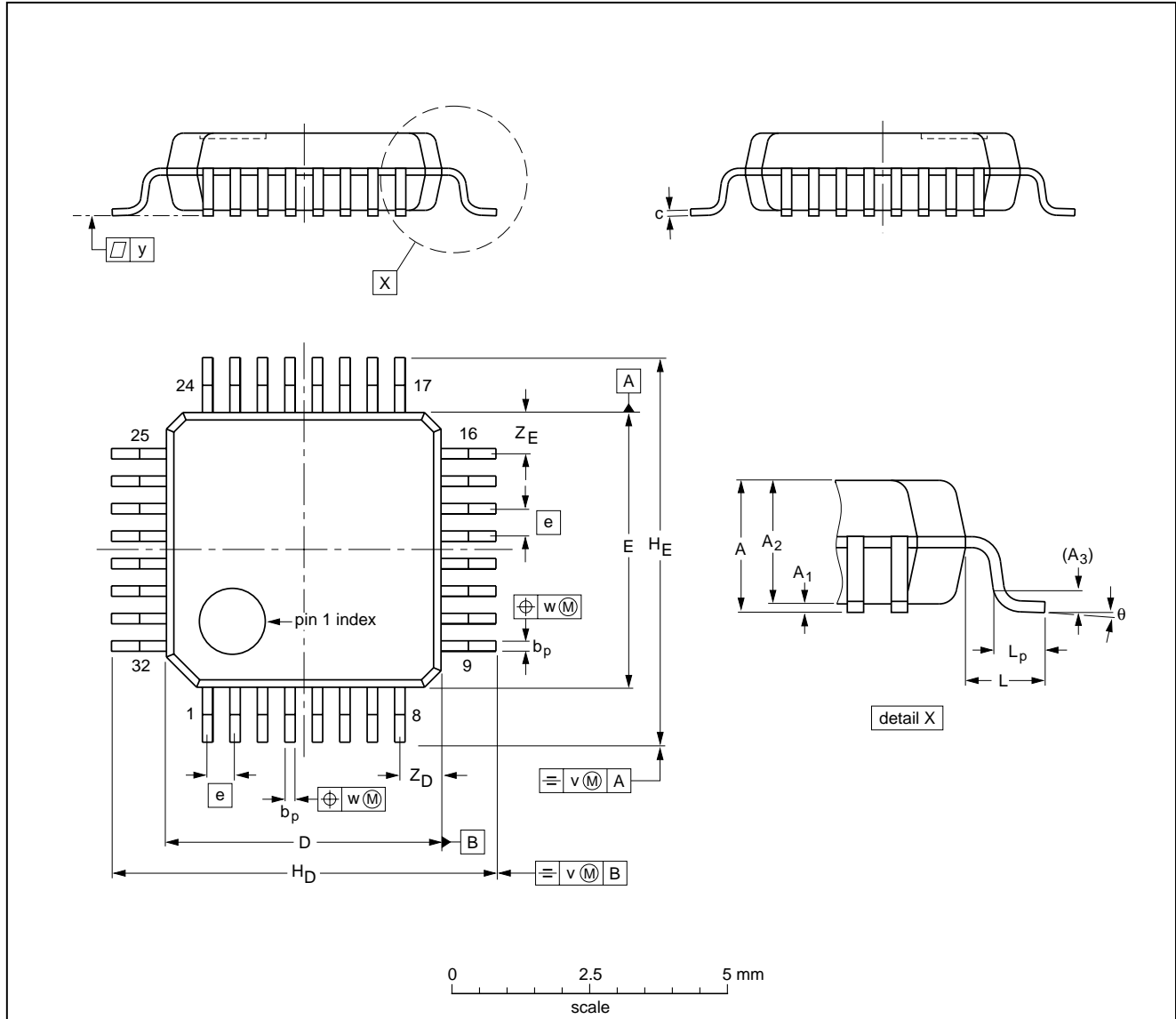

DIMENSIONS (mm are the original dimensions)

UNIT	A max.	A <sub>1</sub>	A <sub>2</sub>	A <sub>3</sub>	b <sub>p</sub>	c	D <sup>(1)</sup>	E <sup>(1)</sup>	e	H <sub>D</sub>	H <sub>E</sub>	L	L <sub>p</sub>	v	w	y	Z <sub>D</sub> <sup>(1)</sup>	Z <sub>E</sub> <sup>(1)</sup>	θ
mm	1.60	0.15 0.05	1.5 1.3	0.25	0.27 0.17	0.18 0.12	5.1 4.9	5.1 4.9	0.5	7.15 6.85	7.15 6.85	1.0	0.75 0.45	0.2	0.12	0.1	0.95 0.55	0.95 0.55	7° 0°

Note

1. Plastic or metal protrusions of 0.25 mm maximum per side are not included.

OUTLINE VERSION	REFERENCES				EUROPEAN PROJECTION	ISSUE DATE
	IEC	JEDEC	EIAJ			
SOT401-1						95-12-19 97-08-04

## IC card interface

## TDA8002

**SOLDERING****Introduction**

There is no soldering method that is ideal for all IC packages. Wave soldering is often preferred when through-hole and surface mounted components are mixed on one printed-circuit board. However, wave soldering is not always suitable for surface mounted ICs, or for printed-circuits with high population densities. In these situations reflow soldering is often used.

This text gives a very brief insight to a complex technology. A more in-depth account of soldering ICs can be found in our *"IC Package Databook"* (order code 9398 652 90011).

**Reflow soldering**

Reflow soldering techniques are suitable for all LQFP and SO packages.

Reflow soldering requires solder paste (a suspension of fine solder particles, flux and binding agent) to be applied to the printed-circuit board by screen printing, stencilling or pressure-syringe dispensing before package placement.

Several methods exist for reflowing; for example, infrared/convection heating in a conveyor type oven. Throughput times (preheating, soldering and cooling) vary between 50 and 300 seconds depending on heating method. Typical reflow peak temperatures range from 215 to 250 °C.

**Wave soldering****LQFP**

Wave soldering is **not** recommended for LQFP packages. This is because of the likelihood of solder bridging due to closely-spaced leads and the possibility of incomplete solder penetration in multi-lead devices.

**CAUTION**

**Wave soldering is NOT applicable for all LQFP packages with a pitch (e) equal or less than 0.5 mm.**

**If wave soldering cannot be avoided, for LQFP packages with a pitch (e) larger than 0.5 mm, the following conditions must be observed:**

- **A double-wave (a turbulent wave with high upward pressure followed by a smooth laminar wave) soldering technique should be used.**
- **The footprint must be at an angle of 45° to the board direction and must incorporate solder thieves downstream and at the side corners.**

**SO**

Wave soldering techniques can be used for all SO packages if the following conditions are observed:

- A double-wave (a turbulent wave with high upward pressure followed by a smooth laminar wave) soldering technique should be used.
- The longitudinal axis of the package footprint must be parallel to the solder flow.
- The package footprint must incorporate solder thieves at the downstream end.

**METHOD (LQFP AND SO)**

During placement and before soldering, the package must be fixed with a droplet of adhesive. The adhesive can be applied by screen printing, pin transfer or syringe dispensing. The package can be soldered after the adhesive is cured.

Maximum permissible solder temperature is 260 °C, and maximum duration of package immersion in solder is 10 seconds, if cooled to less than 150 °C within 6 seconds. Typical dwell time is 4 seconds at 250 °C.

A mildly-activated flux will eliminate the need for removal of corrosive residues in most applications.

**Repairing soldered joints**

Fix the component by first soldering two diagonally-opposite end leads. Use only a low voltage soldering iron (less than 24 V) applied to the flat part of the lead. Contact time must be limited to 10 seconds at up to 300 °C. When using a dedicated tool, all other leads can be soldered in one operation within 2 to 5 seconds between 270 and 320 °C.

## IC card interface

TDA8002

**DEFINITIONS**

<b>Data sheet status</b>	
Objective specification	This data sheet contains target or goal specifications for product development.
Preliminary specification	This data sheet contains preliminary data; supplementary data may be published later.
Product specification	This data sheet contains final product specifications.
<b>Limiting values</b>	
Limiting values given are in accordance with the Absolute Maximum Rating System (IEC 134). Stress above one or more of the limiting values may cause permanent damage to the device. These are stress ratings only and operation of the device at these or at any other conditions above those given in the Characteristics sections of the specification is not implied. Exposure to limiting values for extended periods may affect device reliability.	
<b>Application information</b>	
Where application information is given, it is advisory and does not form part of the specification.	

**LIFE SUPPORT APPLICATIONS**

These products are not designed for use in life support appliances, devices, or systems where malfunction of these products can reasonably be expected to result in personal injury. Philips customers using or selling these products for use in such applications do so at their own risk and agree to fully indemnify Philips for any damages resulting from such improper use or sale.



IC card interface

TDA8002

---

**NOTES**

IC card interface

TDA8002

---

**NOTES**

IC card interface

TDA8002

---

**NOTES**

# Philips Semiconductors – a worldwide company

**Argentina:** see South America

**Australia:** 34 Waterloo Road, NORTH RYDE, NSW 2113,  
Tel. +61 2 9805 4455, Fax. +61 2 9805 4466

**Austria:** Computerstr. 6, A-1101 WIEN, P.O. Box 213, Tel. +43 160 1010,  
Fax. +43 160 101 1210

**Belarus:** Hotel Minsk Business Center, Bld. 3, r. 1211, Volodarski Str. 6,  
220050 MINSK, Tel. +375 172 200 733, Fax. +375 172 200 773

**Belgium:** see The Netherlands

**Brazil:** see South America

**Bulgaria:** Philips Bulgaria Ltd., Energoproject, 15th floor,  
51 James Bourchier Blvd., 1407 SOFIA,  
Tel. +359 2 689 211, Fax. +359 2 689 102

**Canada:** PHILIPS SEMICONDUCTORS/COMPONENTS,  
Tel. +1 800 234 7381

**China/Hong Kong:** 501 Hong Kong Industrial Technology Centre,  
72 Tat Chee Avenue, Kowloon Tong, HONG KONG,  
Tel. +852 2319 7888, Fax. +852 2319 7700

**Colombia:** see South America

**Czech Republic:** see Austria

**Denmark:** Prags Boulevard 80, PB 1919, DK-2300 COPENHAGEN S,  
Tel. +45 32 88 2636, Fax. +45 31 57 0044

**Finland:** Sinikalliontie 3, FIN-02630 ESPOO,  
Tel. +358 9 615800, Fax. +358 9 61580920

**France:** 4 Rue du Port-aux-Vins, BP317, 92156 SURESNES Cedex,  
Tel. +33 1 40 99 6161, Fax. +33 1 40 99 6427

**Germany:** Hammerbrookstraße 69, D-20097 HAMBURG,  
Tel. +49 40 23 53 60, Fax. +49 40 23 536 300

**Greece:** No. 15, 25th March Street, GR 17778 TAVROS/ATHENS,  
Tel. +30 1 4894 339/239, Fax. +30 1 4814 240

**Hungary:** see Austria

**India:** Philips INDIA Ltd, Band Box Building, 2nd floor,  
254-D, Dr. Annie Besant Road, Worli, MUMBAI 400 025,  
Tel. +91 22 493 8541, Fax. +91 22 493 0966

**Indonesia:** see Singapore

**Ireland:** Newstead, Clonskeagh, DUBLIN 14,  
Tel. +353 1 7640 000, Fax. +353 1 7640 200

**Israel:** RAPAC Electronics, 7 Kehilat Saloniki St, PO Box 18053,  
TEL AVIV 61180, Tel. +972 3 645 0444, Fax. +972 3 649 1007

**Italy:** PHILIPS SEMICONDUCTORS, Piazza IV Novembre 3,  
20124 MILANO, Tel. +39 2 6752 2531, Fax. +39 2 6752 2557

**Japan:** Philips Bldg 13-37, Kohnan 2-chome, Minato-ku, TOKYO 108,  
Tel. +81 3 3740 5130, Fax. +81 3 3740 5077

**Korea:** Philips House, 260-199 Itaewon-dong, Yongsan-ku, SEOUL,  
Tel. +82 2 709 1412, Fax. +82 2 709 1415

**Malaysia:** No. 76 Jalan Universiti, 46200 PETALING JAYA, SELANGOR,  
Tel. +60 3 750 5214, Fax. +60 3 757 4880

**Mexico:** 5900 Gateway East, Suite 200, EL PASO, TEXAS 79905,  
Tel. +9-5 800 234 7381

**Middle East:** see Italy

**Netherlands:** Postbus 90050, 5600 PB EINDHOVEN, Bldg. VB,  
Tel. +31 40 27 82785, Fax. +31 40 27 88399

**New Zealand:** 2 Wagener Place, C.P.O. Box 1041, AUCKLAND,  
Tel. +64 9 849 4160, Fax. +64 9 849 7811

**Norway:** Box 1, Manglerud 0612, OSLO,  
Tel. +47 22 74 8000, Fax. +47 22 74 8341

**Philippines:** Philips Semiconductors Philippines Inc.,  
106 Valero St. Salcedo Village, P.O. Box 2108 MCC, MAKATI,  
Metro MANILA, Tel. +63 2 816 6380, Fax. +63 2 817 3474

**Poland:** Ul. Lukiska 10, PL 04-123 WARSZAWA,  
Tel. +48 22 612 2831, Fax. +48 22 612 2327

**Portugal:** see Spain

**Romania:** see Italy

**Russia:** Philips Russia, Ul. Usatcheva 35A, 119048 MOSCOW,  
Tel. +7 095 755 6918, Fax. +7 095 755 6919

**Singapore:** Lorong 1, Toa Payoh, SINGAPORE 1231,  
Tel. +65 350 2538, Fax. +65 251 6500

**Slovakia:** see Austria

**Slovenia:** see Italy

**South Africa:** S.A. PHILIPS Pty Ltd., 195-215 Main Road Martindale,  
2092 JOHANNESBURG, P.O. Box 7430 Johannesburg 2000,  
Tel. +27 11 470 5911, Fax. +27 11 470 5494

**South America:** Rua do Rocio 220, 5th floor, Suite 51,  
04552-903 São Paulo, SÃO PAULO - SP, Brazil,  
Tel. +55 11 821 2333, Fax. +55 11 829 1849

**Spain:** Balmes 22, 08007 BARCELONA,  
Tel. +34 3 301 6312, Fax. +34 3 301 4107

**Sweden:** Kottbygatan 7, Akalla, S-16485 STOCKHOLM,  
Tel. +46 8 632 2000, Fax. +46 8 632 2745

**Switzerland:** Allmendstrasse 140, CH-8027 ZÜRICH,  
Tel. +41 1 488 2686, Fax. +41 1 481 7730

**Taiwan:** Philips Semiconductors, 6F, No. 96, Chien Kuo N. Rd., Sec. 1,  
TAIPEI, Taiwan Tel. +886 2 2134 2865, Fax. +886 2 2134 2874

**Thailand:** PHILIPS ELECTRONICS (THAILAND) Ltd.,  
209/2 Sanpavuth-Bangna Road Prakanong, BANGKOK 10260,  
Tel. +66 2 745 4090, Fax. +66 2 398 0793

**Turkey:** Talatpasa Cad. No. 5, 80640 GÜLTEPE/ISTANBUL,  
Tel. +90 212 279 2770, Fax. +90 212 282 6707

**Ukraine:** PHILIPS UKRAINE, 4 Patrice Lumumba str., Building B, Floor 7,  
252042 KIEV, Tel. +380 44 264 2776, Fax. +380 44 268 0461

**United Kingdom:** Philips Semiconductors Ltd., 276 Bath Road, Hayes,  
MIDDLESEX UB3 5BX, Tel. +44 181 730 5000, Fax. +44 181 754 8421

**United States:** 811 East Arques Avenue, SUNNYVALE, CA 94088-3409,  
Tel. +1 800 234 7381

**Uruguay:** see South America

**Vietnam:** see Singapore

**Yugoslavia:** PHILIPS, Trg N. Pasica 5/v, 11000 BEOGRAD,  
Tel. +381 11 625 344, Fax. +381 11 635 777

**For all other countries apply to:** Philips Semiconductors, Marketing & Sales Communications,  
Building BE-p, P.O. Box 218, 5600 MD EINDHOVEN, The Netherlands, Fax. +31 40 27 24825

**Internet:** <http://www.semiconductors.philips.com>

© Philips Electronics N.V. 1997

SCA55

All rights are reserved. Reproduction in whole or in part is prohibited without the prior written consent of the copyright owner.

The information presented in this document does not form part of any quotation or contract, is believed to be accurate and reliable and may be changed without notice. No liability will be accepted by the publisher for any consequence of its use. Publication thereof does not convey nor imply any license under patent- or other industrial or intellectual property rights.

Printed in The Netherlands

547047/1200/03/pp28

Date of release: 1997 Nov 04

Document order number: 9397 750 02454

*Let's make things better.*

Philips



PHILIPS