



# AP1202

## Dual USB High-Side Power Switch

### ■ Features

- Compliant to USB specifications
- Dual independent switches control
- 2.7V to 5.5V input voltage
- 500mA minimum continuous current per port
- 110mΩ typical on-resistance
- 0.75A maximum short circuit current limit
- Independent open-drain fault flag pins
- 110 μA typical on-state supply current
- 1 μA typical off-state supply current
- Output can be forced higher than input (off-state)
- Thermal shutdown
- 2.4V typical under voltage lockout (UVLO)
- 1ms turn-on (soft-start) and fast turn-off
- Enable active-high (H) or active-low (L)
- 8-pin SOP and PDIP packages

### ■ Applications

- USB hubs
- Hot plug-in power supplies
- Battery-charger circuits

### ■ Pin Assignments

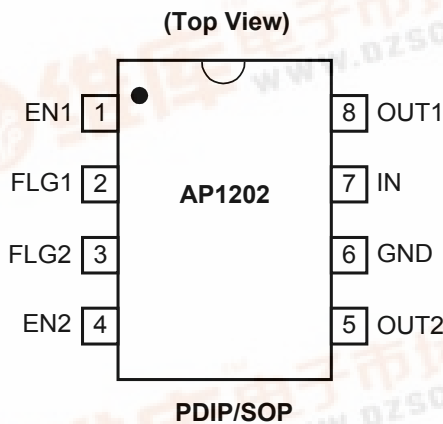

### ■ General Description

The AP1202 series are dual integrated high-side power switch with independent enable and flag functions, optimized for self-powered and bus-powered Universal Serial Bus (USB) applications. The AP1202 series support the following USB requirements: each switch channel supplies up to 500mA as required by USB downstream devices; the switch's low on-resistance meets USB voltage drop requirements; fault current is limited to typically 650mA, well below the UL 25VA safety requirements; and a flag output is available to indicate fault conditions to the local USB controller. Soft start eliminates the momentary voltage drop on the upstream port that may occur when the switch is enabled in bus-powered applications.

Additional features include thermal shutdown to prevent catastrophic switch failure from high-current loads, under voltage lockout (UVLO) to ensure that the device remains off unless there is a valid input voltage present, and 3.3V and 5V logic compatible enable inputs.

### ■ Pin Descriptions

Name	Description
EN1 EN2	Enable: Logic-compatible enable input. ( H: active high, L: active low). Do not float.
FLG1 FLG2	Fault Flag: Active-low, open-drain output. Indicates over current, UVLO, and thermal shutdown.
GND	Supply return.
IN	Supply Input: Output MOSFET drain. Also supplies IC's internal circuitry. Connect to positive supply.
OUT1 OUT2	Switch Output: Output MOSFET source. Typically connect to switched side of load.

## Dual USB High-Side Power Switch

### Ordering Information

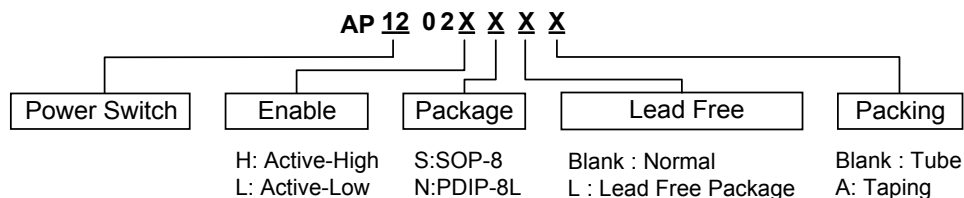

### Block Diagram

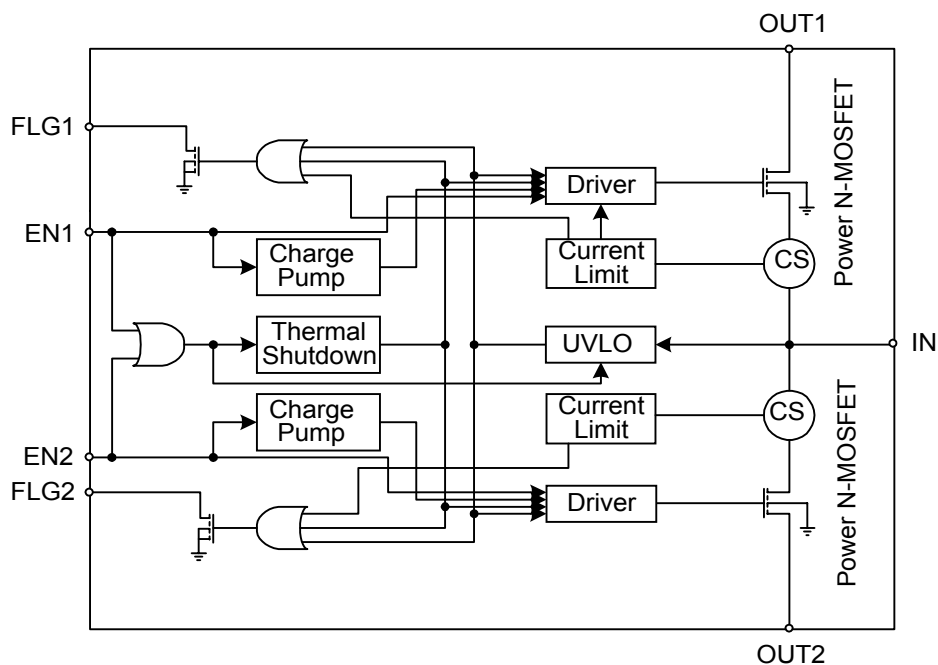

### Absolute Maximum Ratings (Note 1)

Symbol	Parameter	Rating	Unit
$V_{IN}$	Supply Voltage	+7	V
$V_{FLG}$	Fault Flag Voltage	+7	V
$I_{FLG}$	Fault Flag Current	50	mA
$V_{OUT}$	Output Voltage	+7	V
$V_{EN}$	Control Input Range	-0.3 to $V_{IN} + 2$	V
$T_{ST}$	Storage Temperature	-65 to +150	°C
$T_{LEAD}$	Lead Temperature	260	°C
ESD Rating	Note 3	4	KV



## Dual USB High-Side Power Switch

### ■ Operating Ratings (Note 2)

Symbol	Parameter	Rating	Unit
$V_{IN}$	Supply Voltage	+2.7 to +5.5	V
$T_A$	Ambient Operating Temperature	-40 to +85	$^{\circ}C$
$\Theta_{JA}$	Thermal Resistance SOIC	120	$^{\circ}C/W$
$\Theta_{JA}$	Thermal Resistance DIP	100	$^{\circ}C/W$

### ■ Electrical Characteristics (Under Operating Conditions) $V_{IN}=+5V$ ; $T_A=25^{\circ}C$ ; unless noted.

Symbol	Parameter	Conditions	Min.	Typ.	Max.	Unit
$I_{CC}$	Supply Current	switch off, OUT = open (Note 4)		0.50	5	$\mu A$
		all switches on, OUT = open (Note 4)		110	160	$\mu A$
$V_{IT}$	Enable Input Threshold	(Note 4)	0.8	1.7	2.40	V
$I_{EN}$	Enable Input Current	$V_{EN}=0V$ to 5.5V	-1	$\pm 0.01$	1	$\mu A$
$C_{EN}$	Enable Input Capacitance			1		pF
$R_{DS(ON)}$	Switch Resistance	$V_{IN}=2.7V \sim 5.5V$ , $I_{OUT}=500mA$ , each switch		110	140	m $\Omega$
$T_{OND}$	Output Turn-On Delay	$R_L=10\Omega$ each output		30		$\mu S$
$T_R$	Output Turn-On Rise Time	$R_L=10\Omega$ each output		1		mS
$T_{OFFD}$	Output Turnoff Delay	$R_L=10\Omega$ each output		0.5	10	$\mu S$
$T_F$	Output Turnoff Fall Time	$R_L=10\Omega$ each output		0.5	10	$\mu S$
$I_{LEAK}$	Output Leakage Current	each output (output disabled)			10	$\mu A$
$I_{OUT}$	Continuous Load Current	each output	0.6			A
$I_{OS}$	Short-circuit Current Limit	Each output (enable into load),	0.50	0.6	0.7	A
$I_{LIM}$	Current-Limit Threshold	Ramped load applied to enabled output	0.60	0.75	0.90	A
$T_{TS}$	Over-temperature Shutdown Threshold	$T_J$ increasing		140		$^{\circ}C$
		$T_J$ decreasing		130		$^{\circ}C$
$R_{FO}$	Error Flag Output Resistance	$V_{IN}=5V$ , $I_L=10mA$		10	25	$\Omega$
		$V_{IN}=3.3V$ , $I_L=10mA$		15	40	$\Omega$
$I_{FOH}$	Error Flag Off Current	$V_{FLAG}=5V$		0.01	1	$\mu A$
UVLO	UVLO Threshold	$V_{IN}$ = increasing		2.5		V
		$V_{IN}$ = decreasing		2.3		V

**Note 1.** Exceeding the absolute maximum rating may damage the device.

**Note 2.** The device is not guaranteed to function outside its operating rating.

**Note 3.** Devices are ESD sensitive. Handling precautions recommended. Human body model, 1.5k in series with 100pF.

**Note 4.** Off is  $V_{EN} \leq 0.8V$  and on is  $V_{EN} \geq 2.4V$  for the AP1202H. Off is  $V_{EN} \geq 2.4V$  and on is  $V_{EN} \leq 0.8V$  for the AP1202L.



## Dual USB High-Side Power Switch

### ■ Typical Performance Characteristics

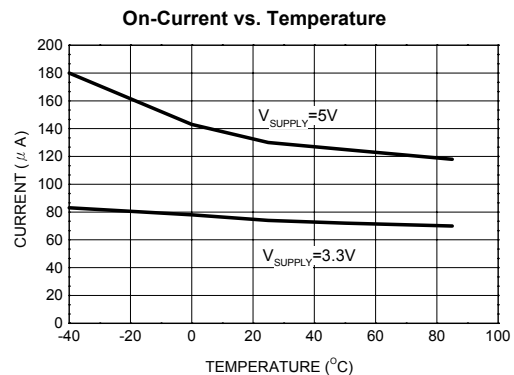
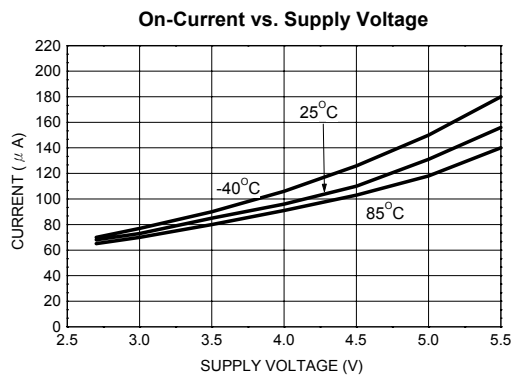
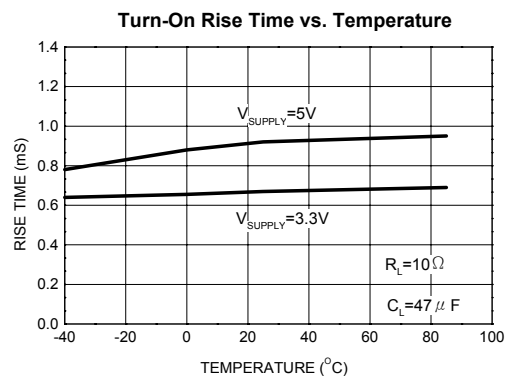
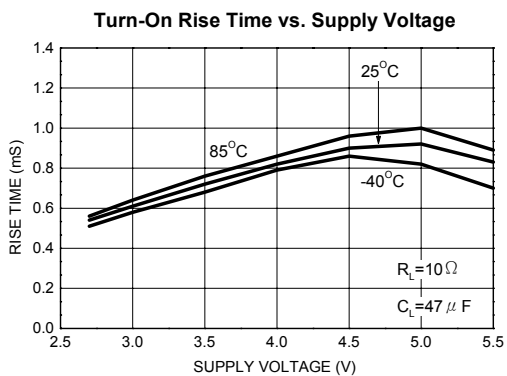
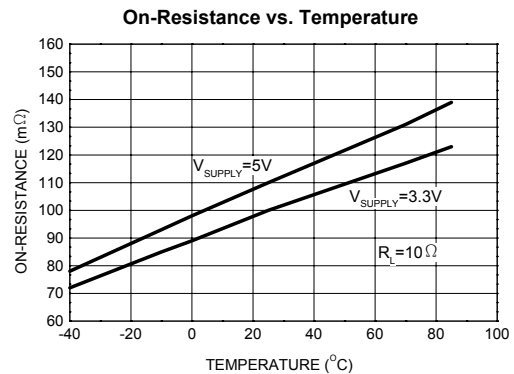
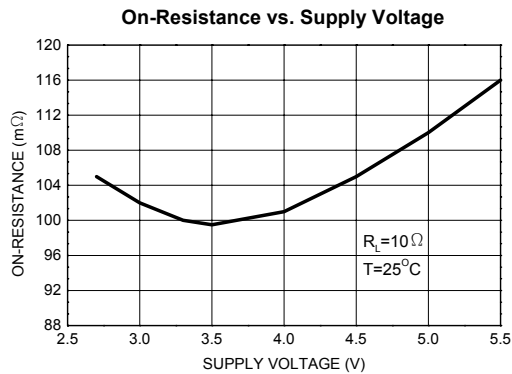

## Dual USB High-Side Power Switch

### ■ Typical Performance Characteristics (Continued)

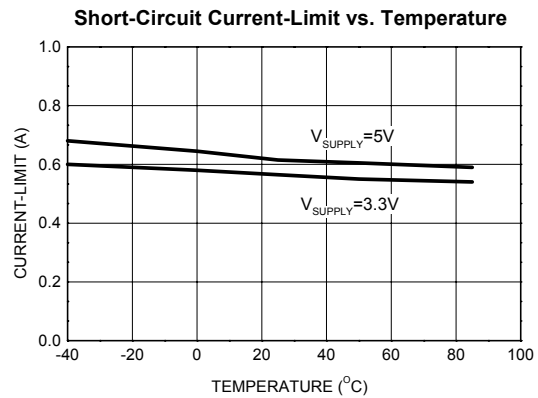
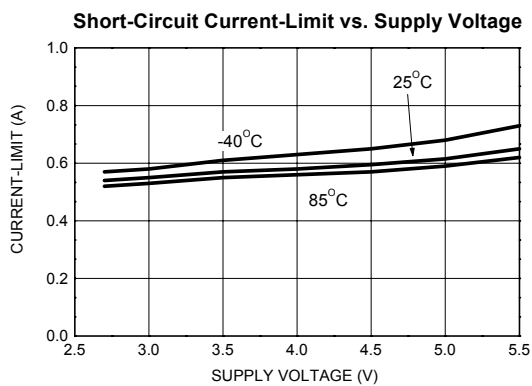
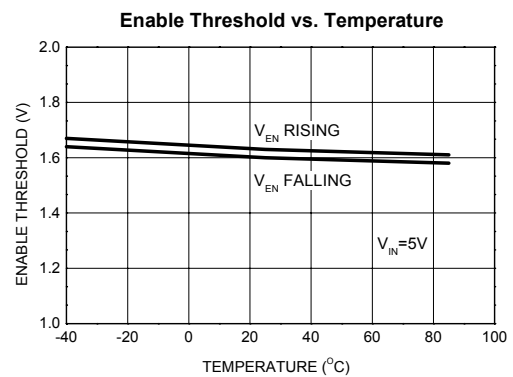
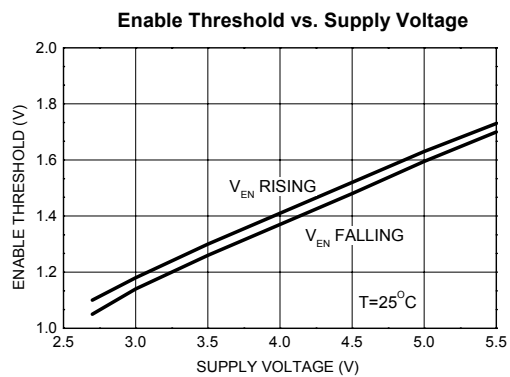
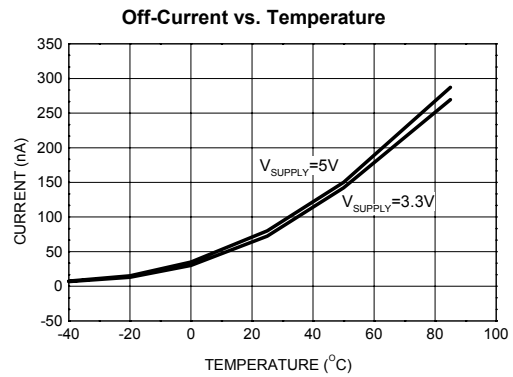
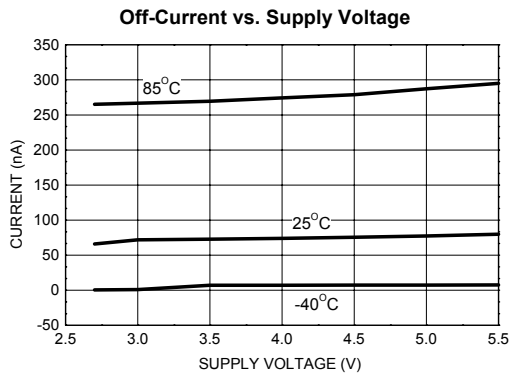

## Dual USB High-Side Power Switch

### ■ Typical Performance Characteristics (Continued)

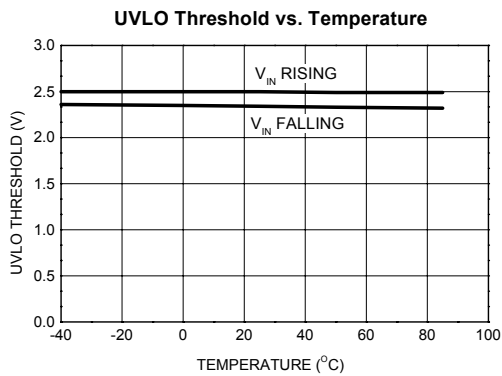
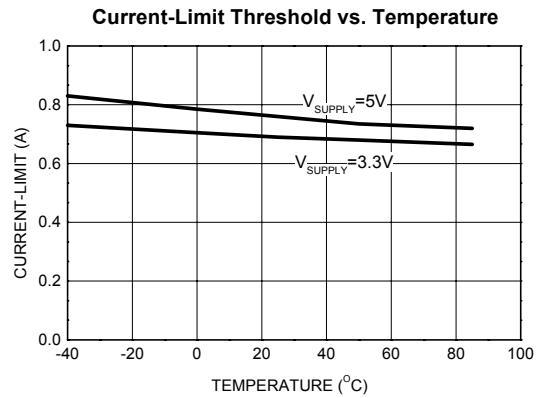
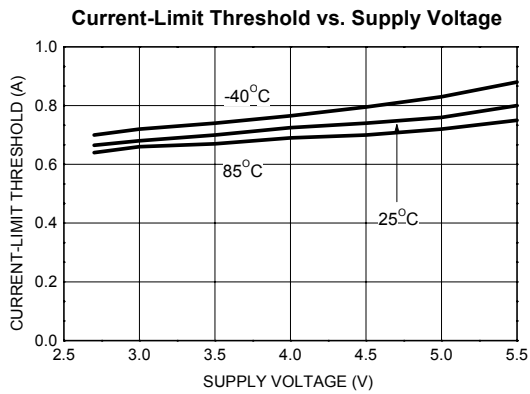

## Dual USB High-Side Power Switch

### ■ Functional Characteristics

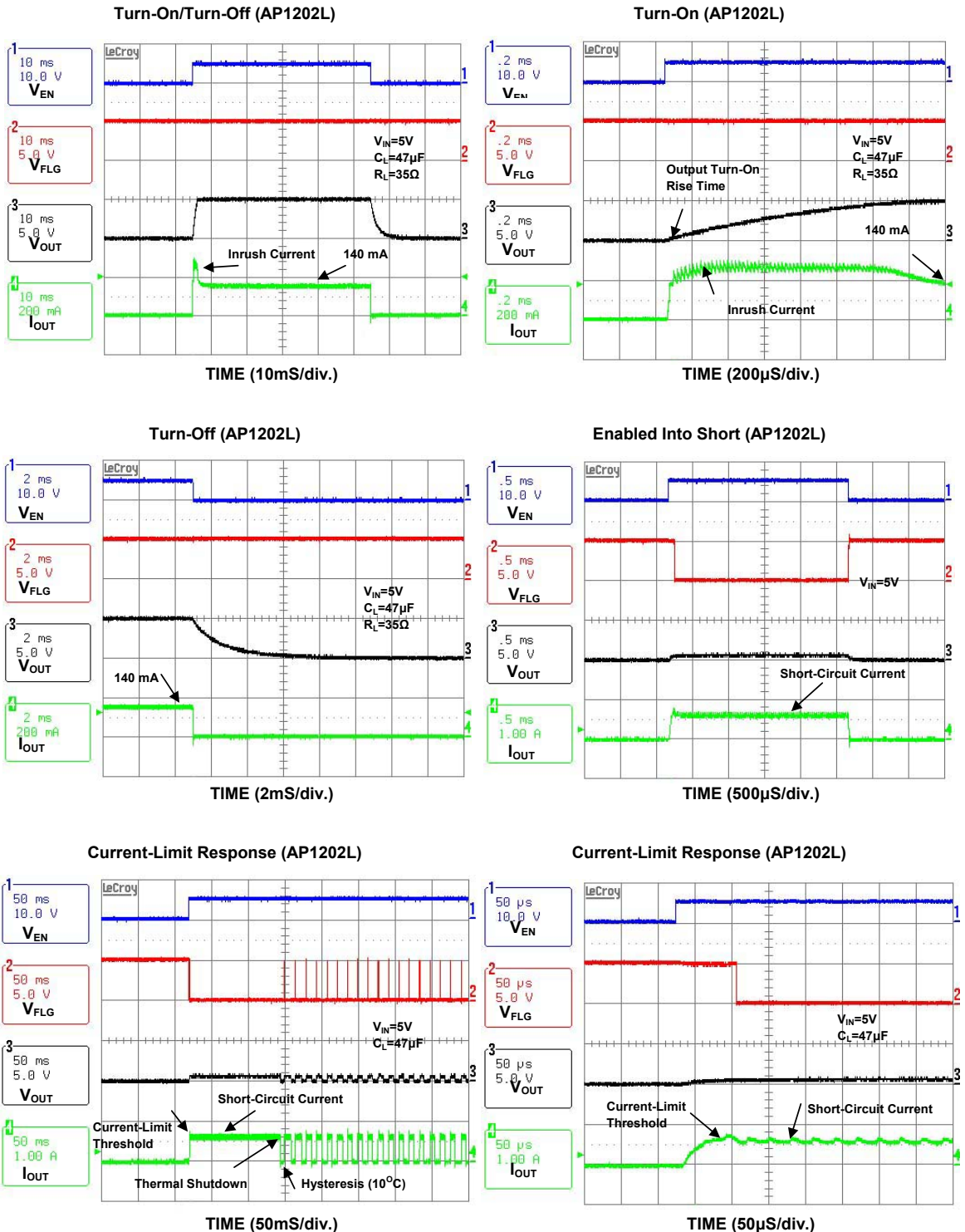

## Dual USB High-Side Power Switch

### ■ Typical Application Circuit

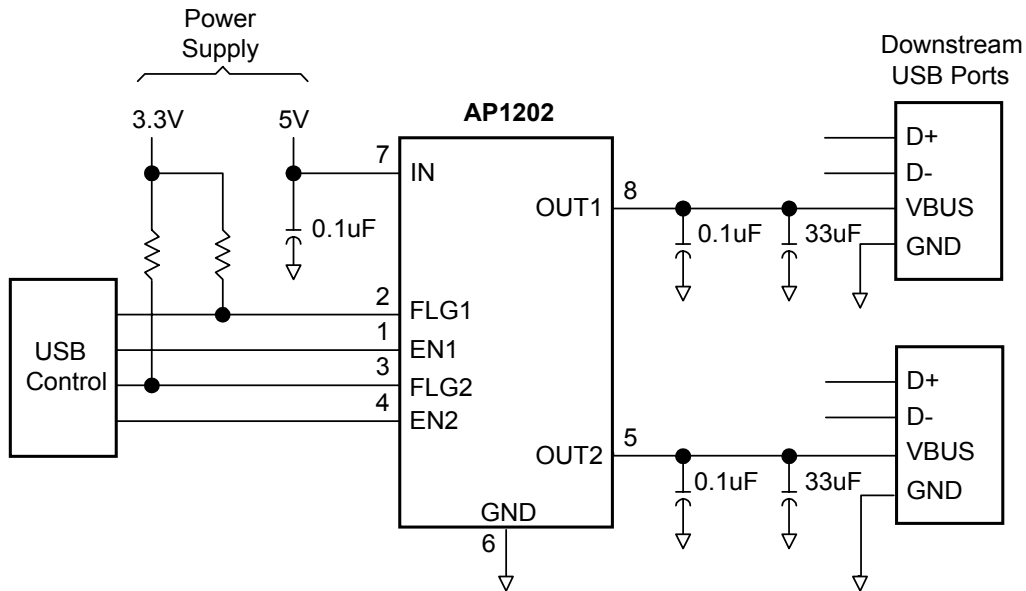

### ■ Test Circuit

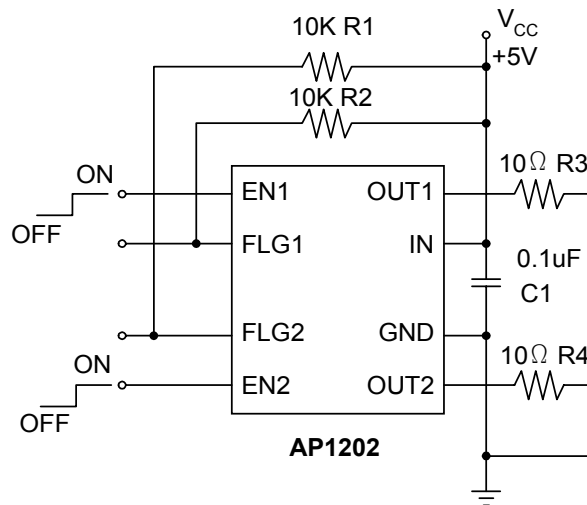





## Dual USB High-Side Power Switch

### ■ Function Description

#### Error Flag

An open-drained output of N-channel MOSFET, the FLG output is pulled low to signal the following fault conditions: input under-voltage, output current limit, and thermal shutdown.

#### Current Limit

The current limit threshold is preset internally. It protects the output MOSFET switches from damage due to undesirable short circuit conditions or excess inrush current often encountered during hot plug-in. The low limit of the current limit threshold of the AP1202 allows a minimum current of 0.5A through the MOSFET switches. A current limit condition will signal the error flag.

#### Thermal Shutdown

When the chip temperature exceeds 140°C for any reason other than over-current fault of either one of the two MOSFET switches, the thermal shutdown function turns off both MOSFET switches and signal the error flag. A hysteresis of 10°C prevents the MOSFETs from turning back on until the chip temperature drops to below 130°C.

#### Supply Filtering

A 0.1 $\mu$ F to 1 $\mu$ F bypass capacitor from IN to GND, located near the device, is strongly recommended to control supply transients. Without a bypass capacitor, an output short may cause sufficient ringing on the input (from supply lead inductance) to damage internal control circuitry.

#### Transient Droop Requirements

USB support dynamic attachment (hot plug-in) of peripherals. A current surge is caused by the input capacitance of downstream device. Ferrite beads are recommended in series with all power and ground connector pins. Ferrite beads reduce EMI and limit the inrush current during hot-attachment by filtering high-frequency signals.

#### Short Circuit Transient

Bulk capacitance provides the short-term transient current needed during a hot-attachment event. With a 33 $\mu$ F, 16V tantalum or 100 $\mu$ F, 10V electrolytic capacitor mounted close to downstream connector per port should provide transient drop protection.

#### Printed Circuit Layout

The power circuitry of USB printed circuit boards requires a customized layout to maximize thermal dissipation and to minimize voltage drop and EMI.

### ■ Marking Information

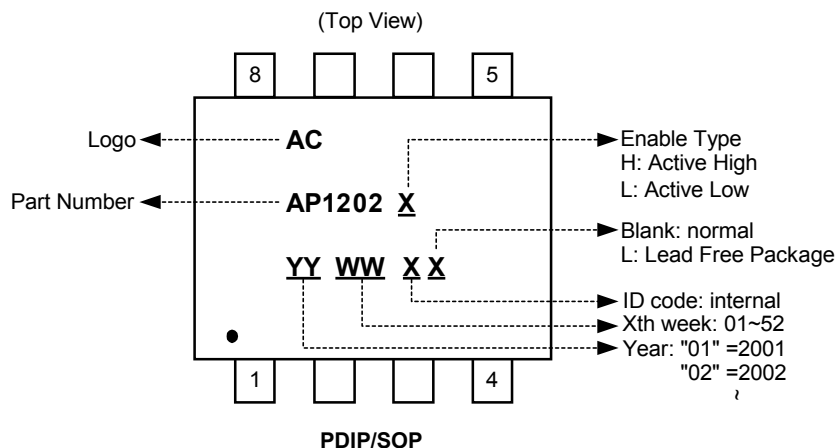



## Dual USB High-Side Power Switch

### ■ Package Information

#### (1) Package Type: PDIP-8L

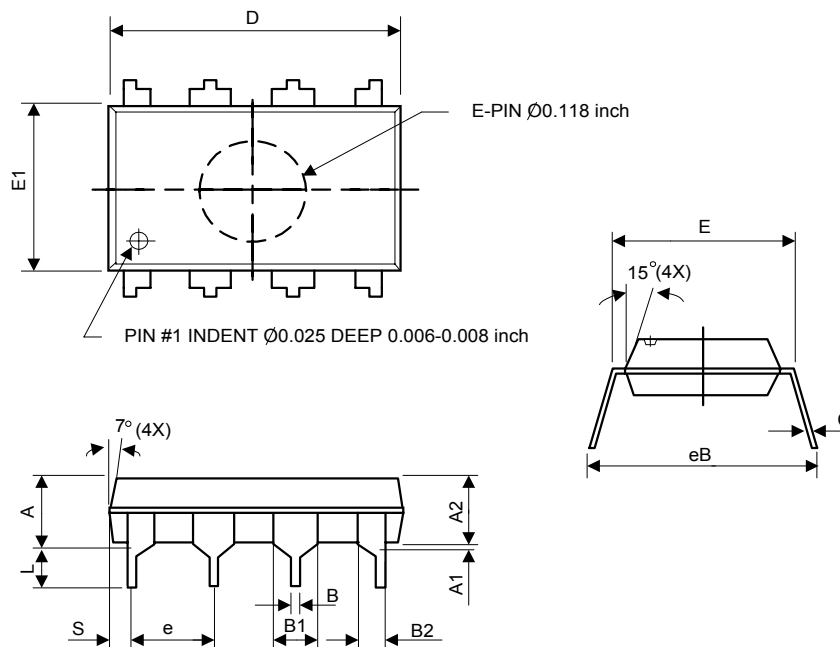

Symbol	Dimensions in millimeters			Dimensions in inches		
	Min.	Nom.	Max.	Min.	Nom.	Max.
A	-	-	5.33	-	-	0.210
A1	0.38	-	-	0.015	-	-
A2	3.1	3.30	3.5	0.122	0.130	0.138
B	0.36	0.46	0.56	0.014	0.018	0.022
B1	1.4	1.52	1.65	0.055	0.060	0.065
B2	0.81	0.99	1.14	0.032	0.039	0.045
C	0.20	0.25	0.36	0.008	0.010	0.014
D	9.02	9.27	9.53	0.355	0.365	0.375
E	7.62	7.94	8.26	0.300	0.313	0.325
E1	6.15	6.35	6.55	0.242	0.250	0.258
e	-	2.54	-	-	0.100	-
L	2.92	3.3	3.81	0.115	0.130	0.150
eB	8.38	8.89	9.40	0.330	0.350	0.370
S	0.71	0.84	0.97	0.028	0.033	0.038

## Dual USB High-Side Power Switch

### ■ Package Information (Continued)

#### (2) Package Type: SOP-8L

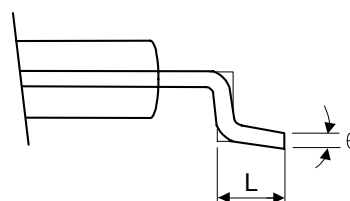
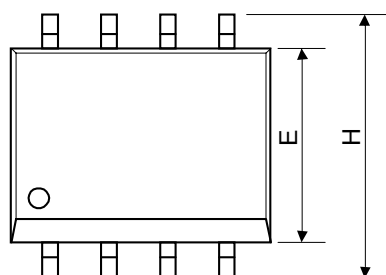

VIEW "A"

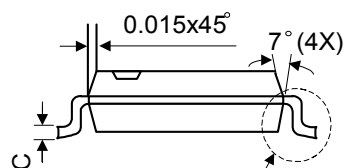
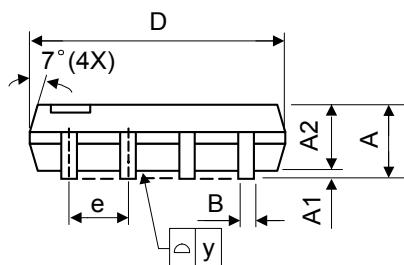

VIEW "A"

Symbol	Dimensions In Millimeters			Dimensions In Inches		
	Min.	Nom.	Max.	Min.	Nom.	Max.
A	1.40	1.60	1.75	0.055	0.063	0.069
A1	0.10	-	0.25	0.040	-	0.100
A2	1.30	1.45	1.50	0.051	0.057	0.059
B	0.33	0.41	0.51	0.013	0.016	0.020
C	0.19	0.20	0.25	0.0075	0.008	0.010
D	4.80	5.05	5.30	0.189	0.199	0.209
E	3.70	3.90	4.10	0.146	0.154	0.161
e	-	1.27	-	-	0.050	-
H	5.79	5.99	6.20	0.228	0.236	0.244
L	0.38	0.71	1.27	0.015	0.028	0.050
y	-	-	0.10	-	-	0.004
$\theta$	0°	-	8°	0°	-	8°