

MC14034B

8-Bit Universal Bus Register

The MC14034B is a bidirectional 8-bit static parallel/serial, input/output bus register. The device contains two sets of input/output lines which allows the bidirectional transfer of data between two buses; the conversion of serial data to parallel form, or the conversion of parallel data to serial form. Additionally the serial data input allows data to be entered shift/right, while shift/left can be accomplished by hard-wiring each parallel output to the previous parallel bit input.

Other useful applications for this device include pseudo-random code generation, sample and hold register, frequency and phase-comparator, address or buffer register, and serial/parallel input/output conversions.

- Bidirectional Parallel Data Input
- Diode Protection on All Inputs
- Supply Voltage Range = 3.0 Vdc to 18 Vdc
- Capable of Driving Two Low-power TTL Loads or One Low-power Schottky TTL Load Over the Rated Temperature Range.
- Pin-for-Pin Replacement for CD4034B.

MAXIMUM RATINGS* (Voltages Referenced to V_{SS})

Symbol	Parameter	Value	Unit
V _{DD}	DC Supply Voltage	- 0.5 to + 18.0	V
V _{in} , V _{out}	Input or Output Voltage (DC or Transient)	- 0.5 to V _{DD} + 0.5	V
I _{in} , I _{out}	Input or Output Current (DC or Transient), per Pin	± 10	mA
P _D	Power Dissipation, per Package†	500	mW
T _{stg}	Storage Temperature	- 65 to + 150	°C
T _L	Lead Temperature (8-Second Soldering)	260	°C

* Maximum Ratings are those values beyond which damage to the device may occur.

† Temperature Derating:

Plastic "P and D/DW" Packages: - 7.0 mW/°C From 65°C To 125°C

Ceramic "L" Packages: - 12 mW/°C From 100°C To 125°C

This device contains protection circuitry to guard against damage due to high static voltages or electric fields. However, precautions must be taken to avoid applications of any voltage higher than maximum rated voltages to this high-impedance circuit. For proper operation, V_{in} and V_{out} should be constrained to the range V_{SS} ≤ (V_{in} or V_{out}) ≤ V_{DD}. Unused inputs must always be tied to an appropriate logic voltage level (e.g., either V_{SS} or V_{DD}). Unused outputs must be left open.

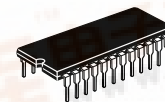

L SUFFIX
 CERAMIC
 CASE 623

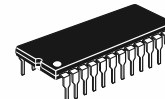

P SUFFIX
 PLASTIC
 CASE 709

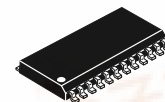

DW SUFFIX
 SOIC
 CASE 751E

ORDERING INFORMATION

MC14XXXBCP Plastic
 MC14XXXBCL Ceramic
 MC14XXXBDW SOIC

T_A = - 55° to 125°C for all packages.

PIN ASSIGNMENT

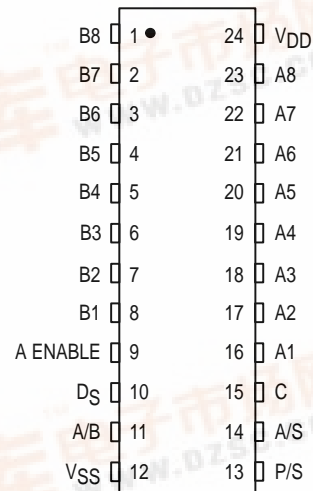

ELECTRICAL CHARACTERISTICS (Voltages Referenced to V_{SS})

Characteristic	Symbol	VDD Vdc	- 55 °C		25 °C			125 °C		Unit	
			Min	Max	Min	Typ #	Max	Min	Max		
Output Voltage $V_{in} = V_{DD}$ or 0 $V_{in} = 0$ or V_{DD}	"0" Level V_{OL}	5.0	—	0.05	—	0	0.05	—	0.05	Vdc	
		10	—	0.05	—	0	0.05	—	0.05		
		15	—	0.05	—	0	0.05	—	0.05		
	"1" Level V_{OH}	5.0	4.95	—	4.95	5.0	—	4.95	—		Vdc
		10	9.95	—	9.95	10	—	9.95	—		
		15	14.95	—	14.95	15	—	14.95	—		
Input Voltage ($V_O = 4.5$ or 0.5 Vdc) ($V_O = 9.0$ or 1.0 Vdc) ($V_O = 13.5$ or 1.5 Vdc) ($V_O = 0.5$ or 4.5 Vdc) ($V_O = 1.0$ or 9.0 Vdc) ($V_O = 1.5$ or 13.5 Vdc)	"0" Level V_{IL}	5.0	—	1.5	—	2.25	1.5	—	1.5	Vdc	
		10	—	3.0	—	4.50	3.0	—	3.0		
		15	—	4.0	—	6.75	4.0	—	4.0		
	"1" Level V_{IH}	5.0	3.5	—	3.5	2.75	—	3.5	—		Vdc
		10	7.0	—	7.0	5.50	—	7.0	—		
		15	11	—	11	8.25	—	11	—		
Output Drive Current ($V_{OH} = 2.5$ Vdc) ($V_{OH} = 4.6$ Vdc) ($V_{OH} = 9.5$ Vdc) ($V_{OH} = 13.5$ Vdc) ($V_{OL} = 0.4$ Vdc) ($V_{OL} = 0.5$ Vdc) ($V_{OL} = 1.5$ Vdc)	Source I_{OH}	5.0	- 1.2	—	- 1.0	- 1.7	—	- 0.7	—	mAdc	
		5.0	- 0.25	—	- 0.2	- 0.36	—	- 0.14	—		
		10	- 0.62	—	- 0.5	- 0.9	—	- 0.35	—		
		15	- 1.8	—	- 1.5	- 3.5	—	- 1.1	—		
	Sink I_{OL}	5.0	0.64	—	0.51	0.88	—	0.36	—		mAdc
		10	1.6	—	1.3	2.25	—	0.9	—		
15	4.2	—	3.4	8.8	—	2.4	—	—			
Input Current	I_{in}	15	—	± 0.1	—	± 0.00001	± 0.1	—	± 1.0	µAdc	
Input Capacitance ($V_{in} = 0$)	C_{in}	—	—	—	—	5.0	7.5	—	—	pF	
Quiescent Current (Per Package)	I_{DD}	5.0	—	5.0	—	0.010	5.0	—	150	µAdc	
		10	—	10	—	0.020	10	—	300		
		15	—	20	—	0.030	20	—	600		
Total Supply Current**† (Dynamic plus Quiescent, Per Package) ($C_L = 50$ pF on all outputs, all buffers switching)	I_T	5.0	$I_T = (2.2 \mu\text{A/kHz}) f + I_{DD}$							µAdc	
		10	$I_T = (4.4 \mu\text{A/kHz}) f + I_{DD}$								
		15	$I_T = (6.6 \mu\text{A/kHz}) f + I_{DD}$								
3-State Output Leakage Current	I_{TL}	15	—	± 0.1	—	± 0.0001	± 0.1	—	± 3.0	µAdc	

#Data labelled "Typ" is not to be used for design purposes but is intended as an indication of the IC's potential performance.

**The formulas given are for the typical characteristics only at 25 °C.

†To calculate total supply current at loads other than 50 pF:

$$I_T(C_L) = I_T(50 \text{ pF}) + (C_L - 50) Vfk$$

where: I_T is in µA (per package), C_L in pF, $V = (V_{DD} - V_{SS})$ in volts, f in kHz is input frequency, and $k = 0.004$.

SWITCHING CHARACTERISTICS* ($C_L = 50 \text{ pF}$, $T_A = 25^\circ\text{C}$)

Characteristic	Symbol	V _{DD} Vdc	Min	Typ #	Max	Unit
Output Rise Time A or B $t_{TLH} = (3.0 \text{ ns/pF}) C_L + 30 \text{ ns}$ $t_{TLH} = (1.5 \text{ ns/pF}) C_L + 15 \text{ ns}$ $t_{TLH} = (1.1 \text{ ns/pF}) C_L + 10 \text{ ns}$	t_{TLH}	5.0 10 15	— — —	180 90 65	360 180 130	ns
Output Fall Time A or B $t_{THL} = (1.5 \text{ ns/pF}) C_L + 25 \text{ ns}$ $t_{THL} = (0.75 \text{ ns/pF}) C_L + 12.5 \text{ ns}$ $t_{THL} = (0.55 \text{ ns/pF}) C_L + 9.5 \text{ ns}$	t_{THL}	5.0 10 15	— — —	100 50 40	200 100 80	ns
Propagation Delay Time A (B) Synchronous Parallel Data Input, B (A) Parallel Data Output $t_{PLH}, t_{PHL} = (1.7 \text{ ns/pF}) C_L + 440 \text{ ns}$ $t_{PHL}, t_{PHL} = (0.66 \text{ ns/pF}) C_L + 172 \text{ ns}$ $t_{PLH}, t_{PHL} = (0.5 \text{ ns/pF}) C_L + 120 \text{ ns}$	$t_{PLH},$ t_{PHL}	5.0 10 15	— — —	525 205 145	1050 410 290	ns
Propagation Delay Time A (B) Asynchronous Parallel Data Input B (A) Parallel Data Output $t_{PLH}, t_{PHL} = (1.7 \text{ ns/pF}) C_L + 420 \text{ ns}$ $t_{PLH}, t_{PHL} = (0.66 \text{ ns/pF}) C_L + 147 \text{ ns}$ $t_{PLH}, t_{PHL} = (0.5 \text{ ns/pF}) C_L + 105 \text{ ns}$	$t_{PLH},$ t_{PHL}	5.0 10 15	— — —	505 180 130	1010 360 260	ns
Clock Pulse Width	t_{WH}	5.0 10 15	340 140 110	170 70 55	— — —	ns
Clock Pulse Frequency	f_{cl}	5.0 10 15	— — —	2.5 6.0 8.0	1.2 3.0 4.0	MHz
Clock Pulse Rise	t_{TLH}, t_{THL}	5.0 10 15	— — —	— — —	15 5 4	μs
A, B Input Setup Time	t_{su}	5.0 10 15	100 45 35	35 15 12	— — —	ns
High Level SE, P/S, A/S Pulse Width	t_{WH}	5.0 10 15	600 270 200	200 90 80	— — —	ns

* The formulas given are for the typical characteristics only at 25°C.

#Data labelled "Typ" is not to be used for design purposes but is intended as an indication of the IC's potential performance.

TRUTH TABLE

"A" Enable	P/S	A/B	A/S	Mode	Operation†
0	0	0	X	Serial	Synchronous Serial data input, A and B Parallel data outputs disabled.
0	0	1	X	Serial	Synchronous Serial data input, B-Parallel data output.
0	1	0	0	Parallel	B Synchronous Parallel data inputs, A-Parallel data outputs disabled.
0	1	0	1	Parallel	B Asynchronous Parallel data inputs, A-Parallel data outputs disabled.
0	1	1	0	Parallel	A-Parallel data inputs disabled, B-Parallel data outputs.
0	1	1	1	Parallel	A-Parallel data inputs disabled, B-Parallel data outputs.
1	0	0	X	Serial	Synchronous serial data input, A-Parallel data output.
1	0	1	X	Serial	Synchronous serial data input, B-Parallel data output.
1	1	0	0	Parallel	B-Synchronous Parallel data input, A-Parallel data output.
1	1	0	1	Parallel	B-Asynchronous Parallel data input, A-Parallel data output.
1	1	1	0	Parallel	A-Synchronous Parallel data input, B-Parallel data output.
1	1	1	1	Parallel	A-Asynchronous Parallel data input, B-Parallel data output.

X = Don't Care

†Outputs change at positive transition of clock in the serial mode and when the A/S input is low in the parallel mode. During transfer from parallel to serial operation, A/S should remain low in order to prevent D_S transfer into flip-flops.

EXPANDED BLOCK DIAGRAM

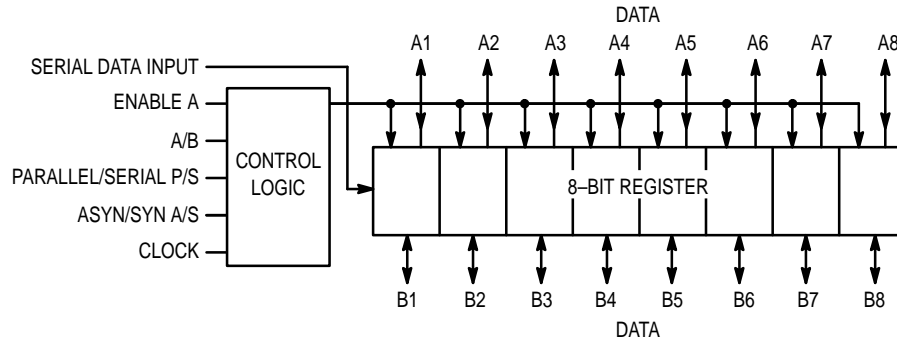

OPERATING CHARACTERISTICS

The MC14034B is composed of eight register cells connected in cascade with additional control logic. Each register cell is composed of one "D" master-slave flip-flop with separate internal clocks, and two data transfer gates allowing the data to be transferred bi-directionally from bus A to bus B and from bus B to bus A, and to be memorized. Besides the single phase clock and the serial data inputs, the control logic provides four other features:

A Enable Input — When high, this input enables the bus A data lines.

A/B Input (Data A or B) — This input controls the direction of data flow: when high, the data flows from bus A to bus

B; when low, the data flows from bus B to bus A.

P/S Input (Parallel/Serial) — This input controls the data input mode (parallel or serial). When high, the data is transferred to the register in a parallel asynchronous mode or a parallel synchronous mode (positive clock transition). When low, the data is entered into the register in a serial synchronous mode (positive clock transition).

A/S Input (Asynchronous/Synchronous to the Clock) — When this input is high, the data is transferred independently of the clock rate; when low, the clock is enabled and the data is transferred synchronously.

LOGIC DIAGRAM

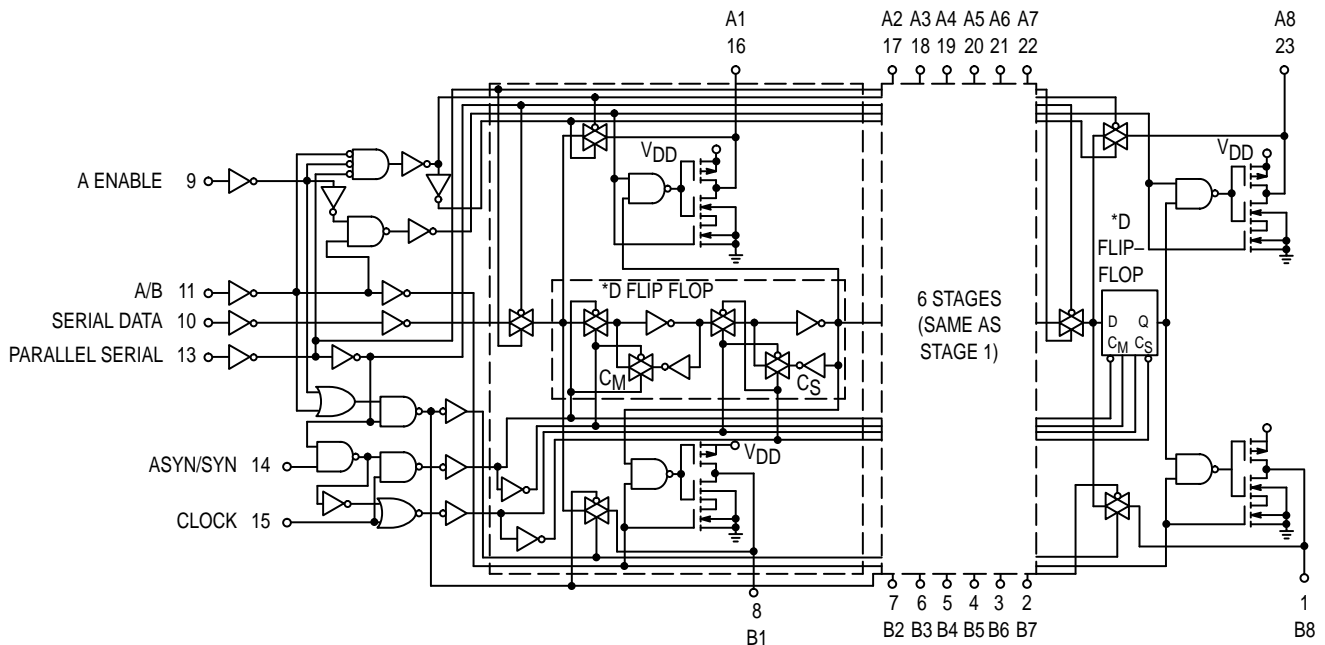

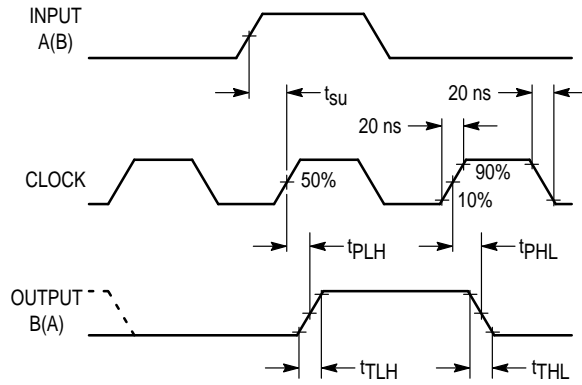

Figure 1. Propagation Delay and Transition Times Waveforms

PROPAGATION AND TRANSITION TIME TEST CIRCUITS

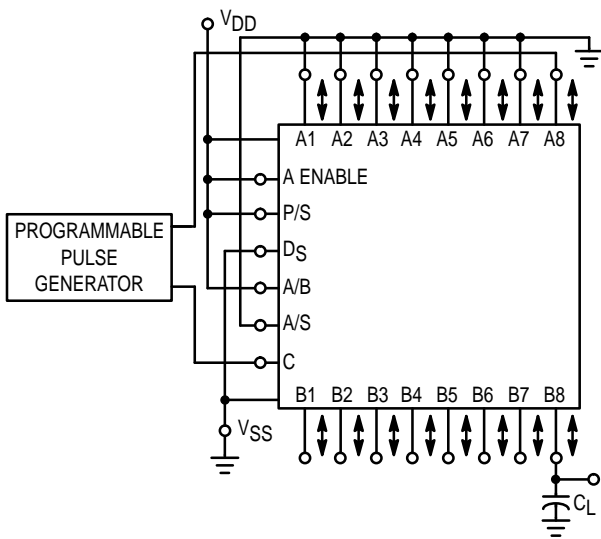

Figure 2. A Synchronous Data Input, B Parallel Data Output and Setup Time

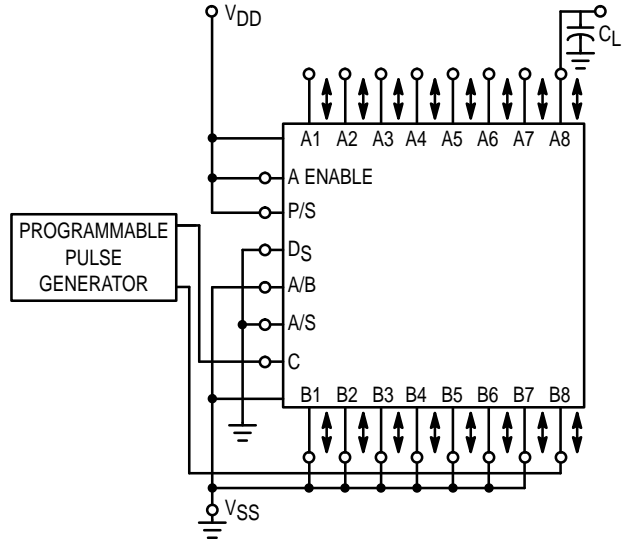

Figure 3. B Synchronous Data Input, A Parallel Data Output and Setup Time

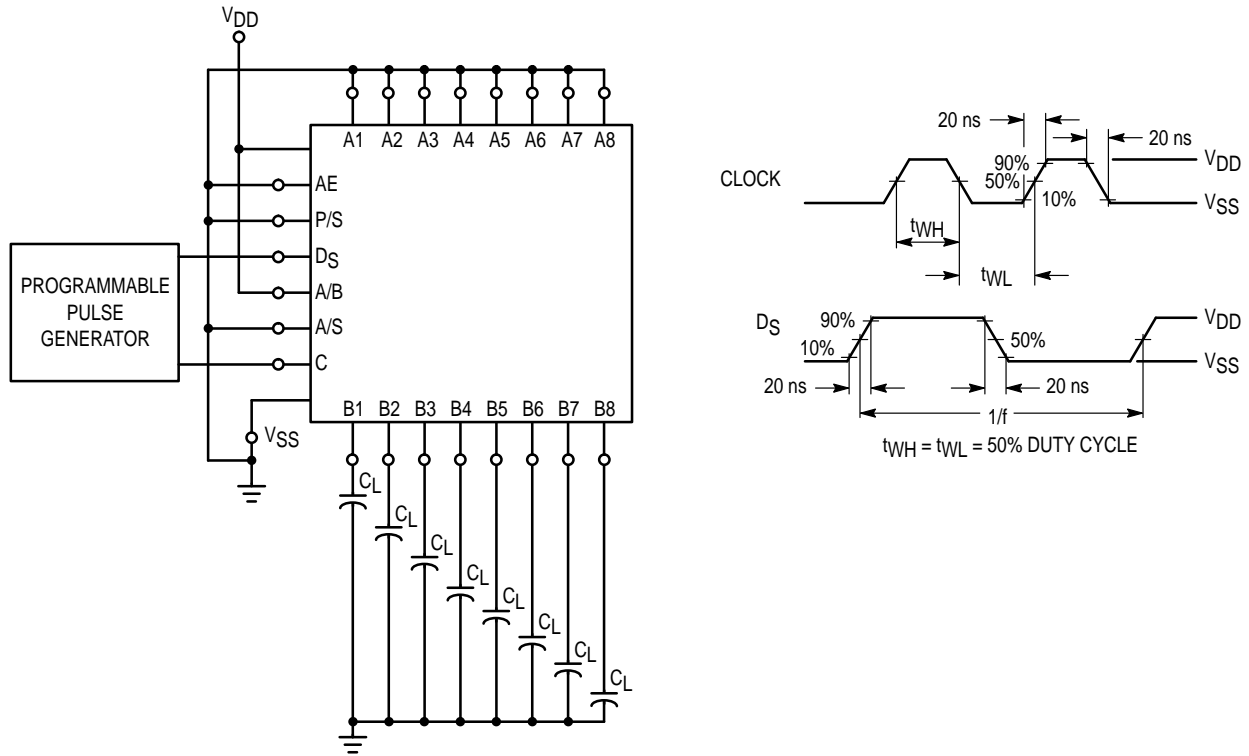

Figure 4. Power Dissipation Test Circuit and Waveforms

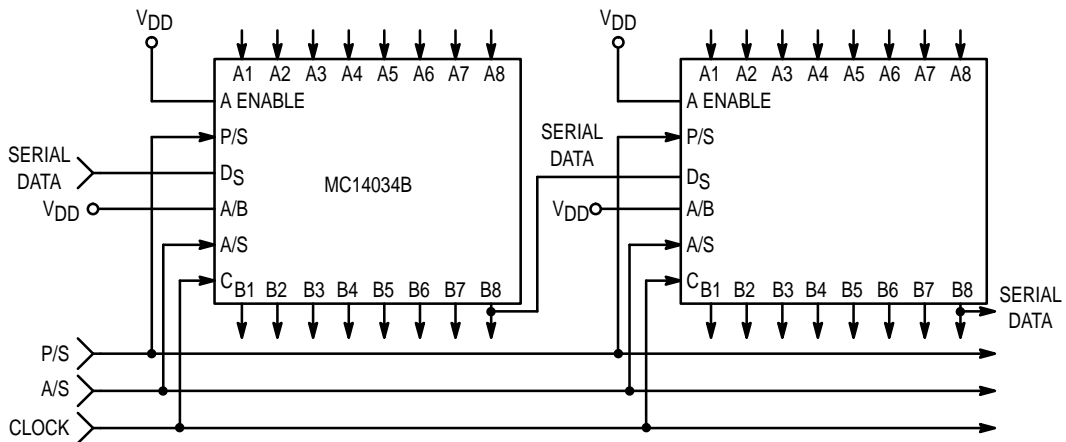
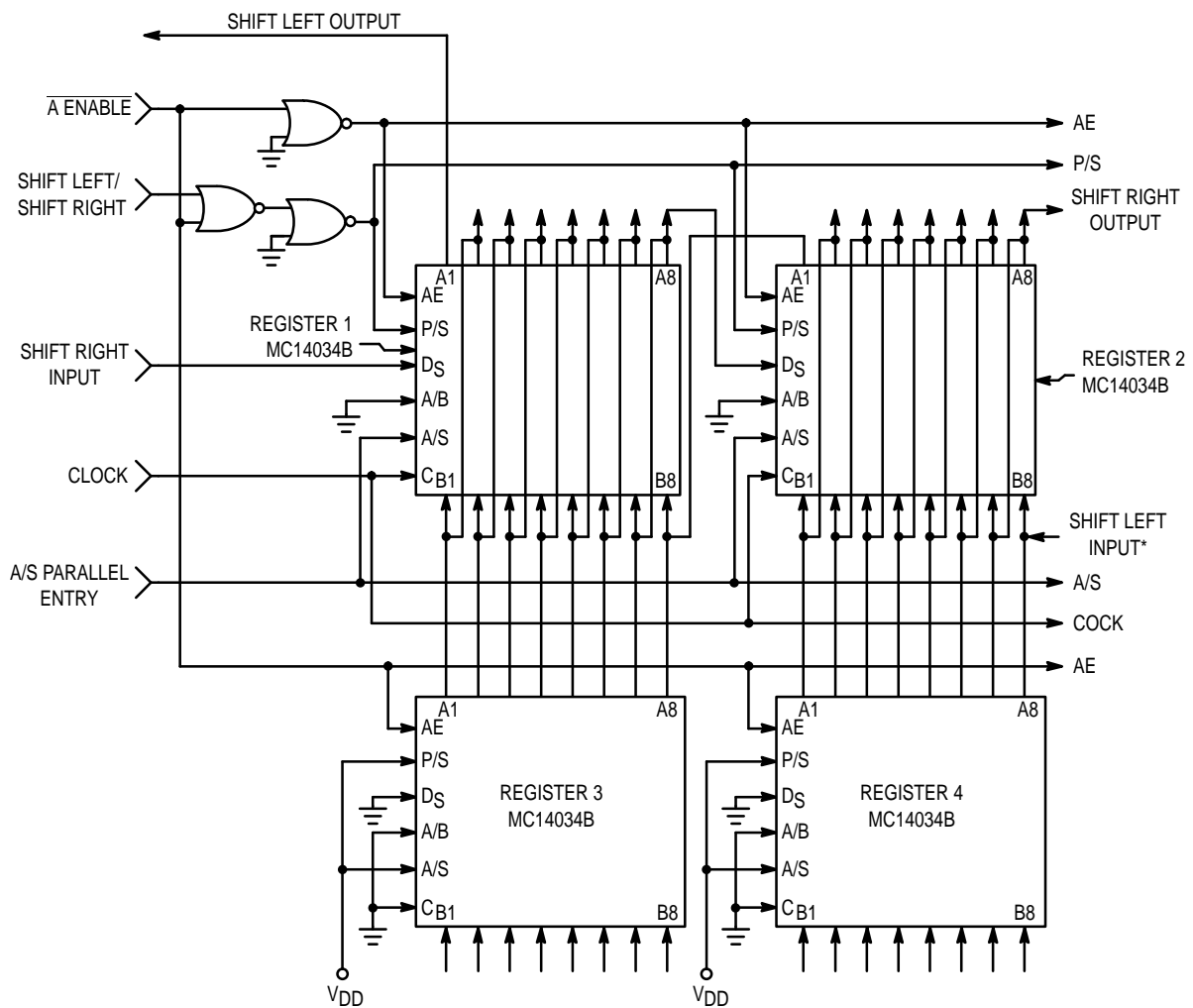

Figure 5. 16-Bit Parallel In/Parallel Out, Parallel In/Serial Out, Serial In/Parallel Out, Serial In/Serial Out Register



A "High" ("Low") on the Shift Left/Shift Right input allows serial data on the Shift Left Input (Shift Right Input) to enter the register on the positive transition of the clock signal. A "high" on the "A" Enable Input disables the "A" parallel data lines on Reg. 1 and 2 and enables the "A" data lines on registers 3 and 4 and allows parallel data into registers 1 and 2. Other logic schemes may be used in place of registers 3 and 4 for parallel loading.

When parallel inputs are not used, Reg. 3 and 4 and associated logic are not required.

*Shift left input must be disabled during parallel entry.

Figure 6. Shift Right/Shift Left with Parallel Inputs

OUTLINE DIMENSIONS

L SUFFIX CERAMIC DIP PACKAGE CASE 623-05 ISSUE M

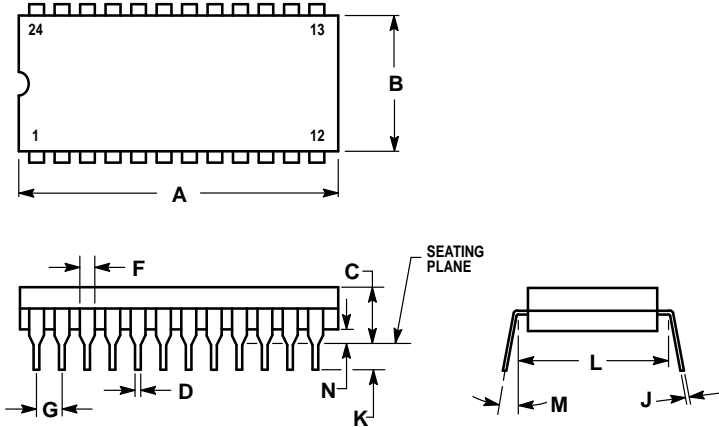

NOTES:

1. DIMENSION L TO CENTER OF LEADS WHEN FORMED PARALLEL.
2. LEADS WITHIN 0.13 (0.005) RADIUS OF TRUE POSITION AT SEATING PLANE AT MAXIMUM MATERIAL CONDITION (WHEN FORMED PARALLEL).

DIM	MILLIMETERS		INCHES	
	MIN	MAX	MIN	MAX
A	31.24	32.77	1.230	1.290
B	12.70	15.49	0.500	0.610
C	4.06	5.59	0.160	0.220
D	0.41	0.51	0.016	0.020
F	1.27	1.52	0.050	0.060
G	2.54 BSC		0.100 BSC	
J	0.20	0.30	0.008	0.012
K	3.18	4.06	0.125	0.160
L	15.24 BSC		0.600 BSC	
M	0°	15°	0°	15°
N	0.51	1.27	0.020	0.050

P SUFFIX PLASTIC DIP PACKAGE CASE 709-02 ISSUE C

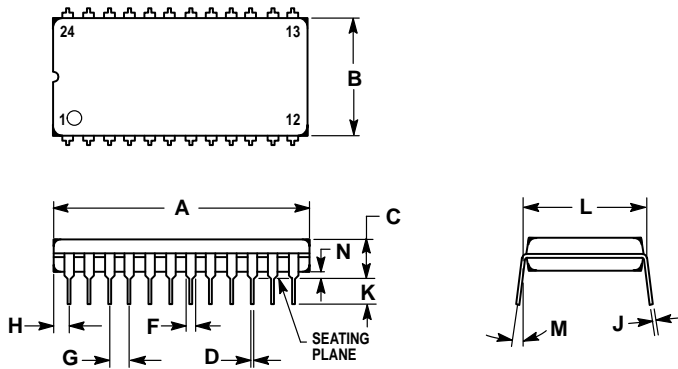

NOTES:

1. POSITIONAL TOLERANCE OF LEADS (D), SHALL BE WITHIN 0.25 (0.010) AT MAXIMUM MATERIAL CONDITION, IN RELATION TO SEATING PLANE AND EACH OTHER.
2. DIMENSION L TO CENTER OF LEADS WHEN FORMED PARALLEL.
3. DIMENSION B DOES NOT INCLUDE MOLD FLASH.

DIM	MILLIMETERS		INCHES	
	MIN	MAX	MIN	MAX
A	31.37	32.13	1.235	1.265
B	13.72	14.22	0.540	0.560
C	3.94	5.08	0.155	0.200
D	0.36	0.56	0.014	0.022
F	1.02	1.52	0.040	0.060
G	2.54 BSC		0.100 BSC	
H	1.65	2.03	0.065	0.080
J	0.20	0.38	0.008	0.015
K	2.92	3.43	0.115	0.135
L	15.24 BSC		0.600 BSC	
M	0°	15°	0°	15°
N	0.51	1.02	0.020	0.040

OUTLINE DIMENSIONS

DW SUFFIX PLASTIC SOIC PACKAGE CASE 751E-04 ISSUE E

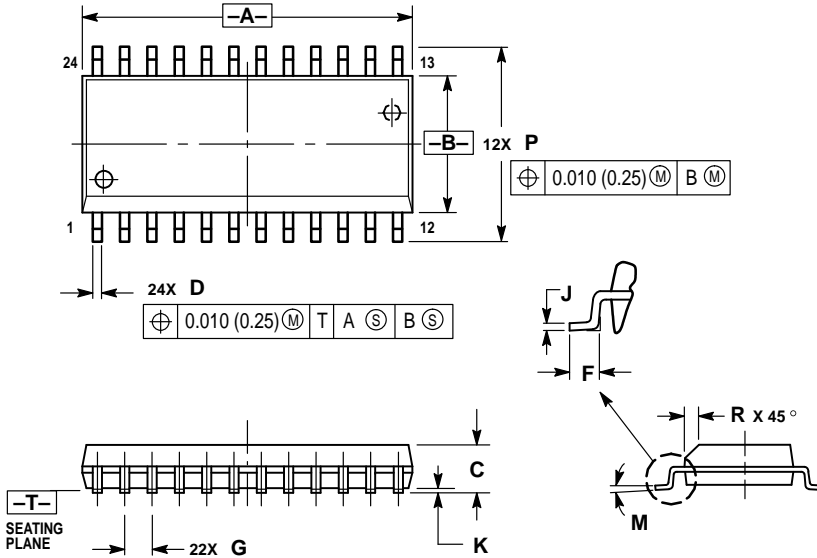

- NOTES:
1. DIMENSIONING AND TOLERANCING PER ANSI Y14.5M, 1982.
 2. CONTROLLING DIMENSION: MILLIMETER.
 3. DIMENSIONS A AND B DO NOT INCLUDE MOLD PROTRUSION.
 4. MAXIMUM MOLD PROTRUSION 0.15 (0.006) PER SIDE.
 5. DIMENSION D DOES NOT INCLUDE DAMBAR PROTRUSION. ALLOWABLE DAMBAR PROTRUSION SHALL BE 0.13 (0.005) TOTAL IN EXCESS OF D DIMENSION AT MAXIMUM MATERIAL CONDITION.

DIM	MILLIMETERS		INCHES	
	MIN	MAX	MIN	MAX
A	15.25	15.54	0.601	0.612
B	7.40	7.60	0.292	0.299
C	2.35	2.65	0.093	0.104
D	0.35	0.49	0.014	0.019
F	0.41	0.90	0.016	0.035
G	1.27 BSC		0.050 BSC	
J	0.23	0.32	0.009	0.013
K	0.13	0.29	0.005	0.011
M	0°	8°	0°	8°
P	10.05	10.55	0.395	0.415
R	0.25	0.75	0.010	0.029

Motorola reserves the right to make changes without further notice to any products herein. Motorola makes no warranty, representation or guarantee regarding the suitability of its products for any particular purpose, nor does Motorola assume any liability arising out of the application or use of any product or circuit, and specifically disclaims any and all liability, including without limitation consequential or incidental damages. "Typical" parameters which may be provided in Motorola data sheets and/or specifications can and do vary in different applications and actual performance may vary over time. All operating parameters, including "Typicals" must be validated for each customer application by customer's technical experts. Motorola does not convey any license under its patent rights nor the rights of others. Motorola products are not designed, intended, or authorized for use as components in systems intended for surgical implant into the body, or other applications intended to support or sustain life, or for any other application in which the failure of the Motorola product could create a situation where personal injury or death may occur. Should Buyer purchase or use Motorola products for any such unintended or unauthorized application, Buyer shall indemnify and hold Motorola and its officers, employees, subsidiaries, affiliates, and distributors harmless against all claims, costs, damages, and expenses, and reasonable attorney fees arising out of, directly or indirectly, any claim of personal injury or death associated with such unintended or unauthorized use, even if such claim alleges that Motorola was negligent regarding the design or manufacture of the part. Motorola and  are registered trademarks of Motorola, Inc. Motorola, Inc. is an Equal Opportunity/Affirmative Action Employer.

How to reach us:

USA/EUROPE/Locations Not Listed: Motorola Literature Distribution;
P.O. Box 20912; Phoenix, Arizona 85036. 1-800-441-2447 or 602-303-5454

MFAX: RMFAX0@email.sps.mot.com - TOUCHTONE 602-244-6609
INTERNET: http://Design-NET.com

JAPAN: Nippon Motorola Ltd.; Tatsumi-SPD-JLDC, 6F Seibu-Butsuryu-Center,
3-14-2 Tatsumi Koto-Ku, Tokyo 135, Japan. 03-81-3521-8315

ASIA/PACIFIC: Motorola Semiconductors H.K. Ltd.; 8B Tai Ping Industrial Park,
51 Ting Kok Road, Tai Po, N.T., Hong Kong. 852-26629298