

# MULTIPLE MODE SYNCHRONOUS DC/DC CONTROLLER

SLVS240 – SEPTEMBER 1999

- **Step-Down DC-DC Converter**
- **Three Operation-Mode**
  - Heavy Load:
    - Fixed Frequency PWM
    - Hysteretic (User Selctable)
  - Light Load:
    - Skip Mode
- **4.5 V to 25 V Input Voltage Range**
- **Adjustable Output Voltage Down to 1.2 V**
- **95% Efficiency**
- **Stand-By Control**
- **Over Current Protection**
- **UVLO for Internal 5 V Regulation**
- **Low Standby Current . . . 0.5 mA Typical**
- **$T_A = -40^{\circ}\text{C}$  to  $85^{\circ}\text{C}$**

**DB PACKAGE  
(TOP VIEW)**

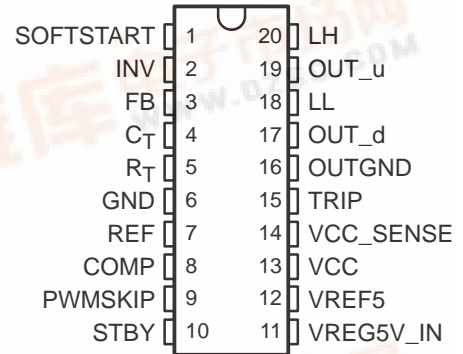

## description

The TPS5103 is a synchronous buck dc/dc controller, designed for notebook PC system power. The controller has three user-selectable operation modes available; hysteretic mode, fixed frequency PWM control, or SKIP control.

In high current applications, where fast transient response is advantageous for reducing bulk capacitance, the hysteretic mode is selected by connecting the Rt pin to Vref5. Selecting the PWM/SKIP modes for less demanding transient applications is ideal for conserving notebook battery life under light load conditions. The device includes high-side and low-side MOSFET drivers capable of driving low R<sub>d</sub>(on) N-channel MOSFETs.

The user-selectable overcurrent protection (OCP) threshold is set by an external TRIP pin resistor in order to protect the system. The TPS5103 is configured so that a current sense resistor is not required, improving the operating efficiency.

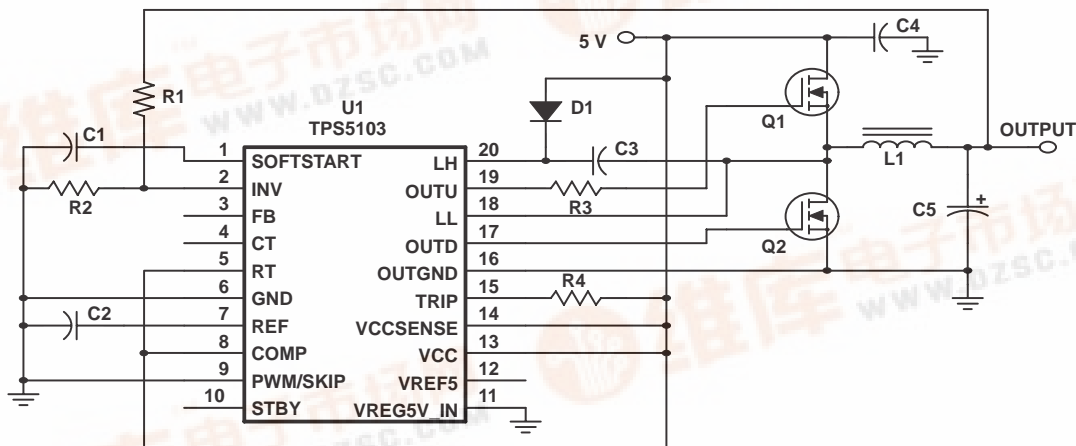

**Figure 1. Typical Design**

Please be aware that an important notice concerning availability, standard warranty, and use in critical applications of Texas Instruments semiconductor products and disclaimers thereto appears at the end of this data sheet.

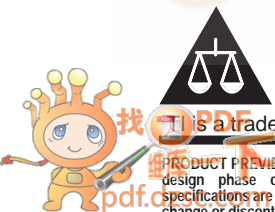

TI is a trademark of Texas Instruments Incorporated.

PRODUCT PREVIEW information concerns products in the formative or design phase of development. Characteristic data and other specifications are design goals. Texas Instruments reserves the right to change or discontinue these products without notice.



# TPS5103 MULTIPLE MODE SYNCHRONOUS DC/DC CONTROLLER

SLVS240 – SEPTEMBER 1999

## functional block diagram

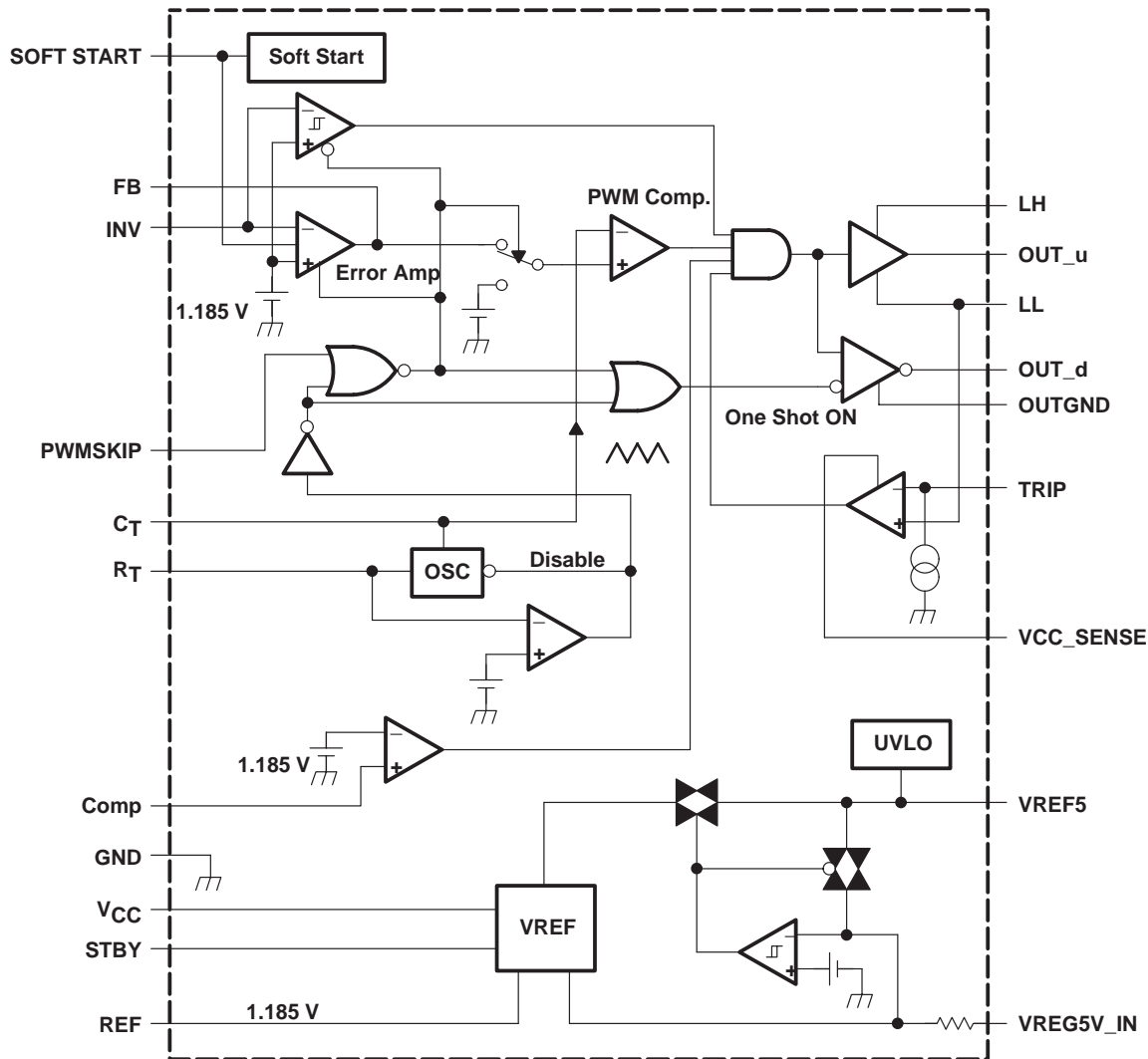

### AVAILABLE OPTIONS

T <sub>A</sub>	PACKAGE	
	SSOP(DB)	EVM
-40 °C to 85 °C	TPS5103IDB	TPS5103EVM-136
	TPS5103IDBR	

# TPS5103

## MULTIPLE MODE SYNCHRONOUS DC/DC CONTROLLER

SLVS240 – SEPTEMBER 1999

### Terminal Functions

TERMINAL NAME	NO.	I/O	DESCRIPTION
COMP	8	I	Comparator input for voltage monitor
C <sub>T</sub>	4	I/O	External capacitor from C <sub>T</sub> to GND for adjusting the triangle oscillator and decreasing the current limiting voltage
FB	3	O	Feedback output of error amp
GND	6		Control GND
INV	2	I	Inverting input of both error amp and hysteretic comparator
LH	20	I/O	Bootstrap. Connect 1 $\mu$ F low-ESR capacitor from LH to LL.
LL	18	I/O	Bootstrap low. High side gate driving return and output current protection. Connect to the junction of the high side and low side FETs for floating drive configuration.
OUT <sub>d</sub>	17	I/O	Gate-drive output for low-side power switching FETs
OUTGND	16		Ground for FET drivers
OUT <sub>u</sub>	19	O	Gate-drive output for high-side power switching FETs
PWMSKIP	9	I	PWM/SKIP mode select L:PWM mode H:SKIP mode
REF	7	O	1.185-V reference voltage output
R <sub>T</sub>	5	I/O	External resistor connection for adjusting the triangle oscillator.
SOFTSTART	1	I	External capacitor from SOFTSTART to GND for soft start control
STBY	10	I	Standby control
TRIP	15	I	External resistor connection for output current control
V <sub>CC</sub>	13	I	Supply voltage input
V <sub>CC_SENSE</sub>	14	I	Supply voltage sense for current protection
VREF5	12	O	5-V-internal regulator output
VREG5V_IN	11	I	External 5-V input (input voltage range = 4.5 V to 25 V)

# TPS5103

## MULTIPLE MODE SYNCHRONOUS DC/DC CONTROLLER

SLVS240 – SEPTEMBER 1999

---

### detailed description

#### REF

The reference voltage is used for the output voltage setting and the voltage protection (COMP). The tolerance is 1.5% typically.

#### VREF5

An internal linear voltage regulator is used for the high-side driver bootstrap voltage. Since the input voltage range is from 4.5 V to 25 V, this voltage offers a fixed voltage for the bootstrap voltage so that the design for the bootstrap is much easier. The tolerance is 6%.

#### hysteretic comparator

The hysteretic comparator is used to regulate the output voltage of the synchronous-buck converter. The hysteresis is set internally and is typically 9.7 mV. The total delay time from the comparator input to the driver output is typically 400 ns for going both high and low.

#### error amplifier

The error amplifier is used to sense the output voltage of the synchronous buck converter. The negative input of the error amplifier is connected to the Vref voltage (1.185 V) with a resistive divider network. The output of the error amplifier is brought out to the FB terminal to be used for loop gain compensation.

#### low-side driver

The low-side driver is designed to drive low-Rds(on) n-channel MOSFETs. The maximum drive voltage is 5 V from VREF5. The current rating of driver is typically 1.2 A at sink current, -1.5 A at source current.

#### high-side driver

The high-side driver is designed to drive low-Rds(on) n-channel MOSFETs. The current rating of the driver is 1.2 A at sink current, -1.7 A at source current. When configured as a floating driver, the bias voltage to the driver is developed from the VREF5, limiting the maximum drive voltage between OUT\_u and LL to 5 V. The maximum voltage that can be applied between LH and OUTGND is 30 V.

#### driver deadtime control

The deadtime control prevents shoot-through current from flowing through the main power FETs. During switching transitions the deadtime control actively controls the turnon time of the MOSFET drivers. The typical deadtime from the low-side-driver-off to the high-side-driver-on is 90 ns, and 110 ns from high-side-driver-off to low-side-driver-on.

#### COMP

COMP is designed for use with a regulation output monitor. COMP also functions as an internal comparator used for any voltage protection such as the input under voltage protection. If the input voltage is lower than the setpoint, the comparator turns off and prevents external parts from damage. The inverting terminal of the comparator is internally connected to REF (1.185 V).

#### current protection

Current protection is achieved by sensing the high-side power MOSFET drain-to-source voltage drop during on-time through VCC\_SENSE and LL terminals. An external resistor between Vin and TRIP terminal with the internal current source connected to the current comparator negative input adjusts the current limit. The typical internal current source value is 15  $\mu$ A in PWM mode, 5  $\mu$ A in SKIP mode. When the voltage on the positive terminal is lower than the negative terminal, the current comparator turns on the trigger, and then activates the oscillator. This oscillator repeatedly reset the trigger until the over current condition is removed. The capacitor on the C\_T terminal can be open or added to adjust the reset frequency.

# TPS5103 MULTIPLE MODE SYNCHRONOUS DC/DC CONTROLLER

SLVS240 – SEPTEMBER 1999

## detailed description (continued)

### softstart

SOFTSTART sets the sequencing of the output for any possibility. The capacitor value for a start-up time can be calculated by the following equation:  $C = 2 \times T$  ( $\mu\text{F}$ ) where C is the external capacitor value, T is the required start-up time in (ms).

### standby

This controller can be switched into standby mode by grounding the STBY terminal. When it is in standby mode, the quiescent current is less than 1.0  $\mu\text{A}$ .

### UVLO

The under-voltage-lock-out (ULVO) threshold is approximately 3.8 V. The typical hysteresis is 55 mV.

### 5-V Switch

5-V Switch if the internal 5-V switch senses a 5-V input from REG5V terminal, the internal 5-V linear regulator will be disconnected from the MOSFET drivers. The external 5 V will be used for both the low-side driver and the high-side bootstrap, thus increasing the efficiency.

### PWM/SKIP switch

The PWM/SKIP switch selects the output operating mode. This controller has three operational modes, PWM, SKIP, and Hysteretic. The PWM and SKIP mode control should be used for slower transient applications.

### oscillator

The oscillator gives a triangle wave by connecting an external resistor to the  $R_T$  terminal and an external capacitor to the  $C_T$  terminal. The voltage amplitude is 0.43 V ~ 1.17 V. This wave is connected to the non-inverting input of the PWM comparator.

**Comparison Table Between PWM Mode and Hysteretic Mode**

MODE	PWM	HYSTERETIC
Frequency	Fixed	Not Fixed
Transient Response	Normal	Very fast
Feed back compensation	Need	Needless

# TPS5103

## MULTIPLE MODE SYNCHRONOUS DC/DC CONTROLLER

SLVS240 – SEPTEMBER 1999

### absolute maximum ratings over operating free-air temperature (unless otherwise noted)†

Supply voltage, $V_{CC}$ (see Note 1)	–0.3 V to 27 V
Input voltage, $V_I$ , INV, $C_T$ , $R_T$ , PWM/SKIP, SOFTSTART, COMP	–0.3 V to 7 V
Input voltage, VREG5V_IN	–0.3 V to 6 V
Input voltage, STBY	–0.3 V to 15 V
Input voltage, TRIP, $V_{CC\_SENSE}$	–0.3 V to 27 V
Output current, $I_O$	3 A
Low level output voltage, $V_{OL}$	–0.3 V to 27 V
High level output voltage, $V_{OH}$	–0.3 V to 32 V
Reference voltage, $V_{ref}$	–0.3 V to 3 V
Operating free-air temperature range, $T_A$	–40°C to 85°C
Operating virtual junction temperature range, $T_J$	–125°C
Storage temperature range, $T_{stg}$	–55°C to 150°C

† Stresses beyond those listed under “absolute maximum ratings” may cause permanent damage to the device. These are stress ratings only, and functional operation of the device at these or any other conditions beyond those indicated under “recommended operating conditions” is not implied. Exposure to absolute-maximum-rated conditions for extended periods may affect device reliability.

- NOTES: 1. All voltage values are with respect to the network ground terminal.  
 2. See Dissipation Rating Table for free-air temperature range above 25°C.

DISSIPATION RATING TABLE

PACKAGE	$T_A \leq 25^\circ\text{C}$ POWER RATING	DERATING FACTOR ABOVE $T_A = 25^\circ\text{C}$	$T_A = 85^\circ\text{C}$ POWER RATING
DB	801 mW	6.408mW/°C	416 mW

### recommended operating conditions

		MIN	NOM	MAX	UNIT
$V_{CC}$	Supply voltage	4.5		25	V
$V_I$	Input voltage	INV, CT, RT, COMP, PWM_SKIP, SOFTSTART		6	V
		VREG5V_IN		5.5	
		STBY		12	
		TRIP, $V_{CC\_SENSE}$		25	
$R_T$ ‡	Oscillator frequency	Timing register		82	kΩ
$C_T$ ‡		Timing capacitor		100	pF
f		Frequency		200	kHz
$T_A$	Operating temperature range	–40		85	°C

‡ Not a JEDEC symbol.

# TPS5103

## MULTIPLE MODE SYNCHRONOUS DC/DC CONTROLLER

SLVS240 – SEPTEMBER 1999

**electrical characteristics over recommended operating free-air temperature range,  $V_{CC} = 7\text{ V}$  (unless otherwise noted)**

### reference voltage

PARAMETER		TEST CONDITIONS	MIN	TYP	MAX	UNIT
$V_{ref}$	Reference voltage	$T_A = 25^\circ\text{C}$ , $I_{vref} = 50\ \mu\text{A}$	1.167	1.185	1.203	V
		$I_{vref} = 50\ \mu\text{A}^\ddagger$	1.155		1.215	
Regin	Line regulation <sup>†</sup>	$V_{CC} = 4.5\text{ V to }25\text{ V}$ , $I = 50\ \mu\text{A}$		0.2	12	mV
Regl	Load regulation <sup>†</sup>	$I = 1\ \mu\text{A to }1\text{ mA}$		0.5	10	mV

<sup>†</sup> Not a JEDEC symbol.

### oscillator

PARAMETER		TEST CONDITIONS	MIN	TYP	MAX	UNIT
f	Frequency	PWM mode			500	kHz
$R_T$	Timing resistor		47			k $\Omega$
fdv	Frequency change <sup>†</sup>	$V_{CC} = 4.5\text{ V to }25\text{ V}$		0.1%		
fdt		$T_A = -40^\circ\text{C to }85^\circ\text{C}$		2%		
$V_{HL}^\ddagger$	High-level output voltage	DC includes internal comparator error	1	1.1	1.2	V
		$f = 200\text{ kHz}$ , includes internal comparator error		1.17		
$V_{LL}^\ddagger$	Low-level output voltage	DC includes internal comparator error	0.4	0.5	0.6	V
		$f = 200\text{ kHz}$ , includes internal comparator error		0.43		

<sup>†</sup> Not a JEDEC symbol.

<sup>‡</sup> The output voltages of oscillator ( $f = 200\text{ kHz}$ ) are ensured by design.

### error amp

PARAMETER		TEST CONDITIONS	MIN	TYP	MAX	UNIT
V	Input offset voltage	$T_A = 25^\circ\text{C}$		2	10	mV
$A_v$	Open-loop voltage gain <sup>†</sup>		50			dB
GB	Unity-gain bandwidth <sup>†</sup>			0.8		MHz
$I_O$	Output sink current	$V_O = 0.4\text{ V}$	30	45		$\mu\text{A}$
$I_S$	Output source current	$V_O = 1\text{ V}$		300		$\mu\text{A}$

<sup>†</sup> Not a JEDEC symbol.

### hysteresis comparator<sup>§</sup>

PARAMETER		TEST CONDITIONS	MIN	TYP	MAX	UNIT
$V_{hsy}$	Hysteresis window	Hysteretic mode	6	9.7	13	mV
$V_p - V_S$	Offset voltage			2		mV
I	Bias current			10		pA
$t_{PHL}$	Propagation delay from INV to OUT_U	TTL input signal		230		ns
$t_{PLH}$		10 mV overdrive on hysteresis band signal		400		ns

<sup>§</sup> The numbers in the table include the driver delay. All numbers are ensured by design.

### control

PARAMETER		TEST CONDITIONS	MIN	TYP	MAX	UNIT
$V_{IHA}$	High-level input voltage	STBY	2.5			V
		PWM_SKIP	2			
$V_{ILA}$	Low-level input voltage	STBY			0.5	V
		PWM_SKIP			0.5	

# TPS5103

## MULTIPLE MODE SYNCHRONOUS DC/DC CONTROLLER

SLVS240 – SEPTEMBER 1999

electrical characteristics over recommended operating free-air temperature range,  $V_{CC} = 7\text{ V}$  (unless otherwise noted) (continued)

### 5-V regulator

PARAMETER		TEST CONDITIONS	MIN	TYP	MAX	UNIT
$V_O$	Output voltage	$I = 10\text{ mA}$	4.7		5.3	V
Regin	Line regulation†	$V_{CC} = 5.5\text{ V to }25\text{ V}, I = 10\text{ mA}$			20	mV
Regl	Load regulation†	$I = 1\text{ mA to }10\text{ mA}, V_{CC} = 5.5\text{ V}$			40	mV
$I_{OS}$	Short-circuit output current	$V_{ref} = 0\text{ V}$		70		mA

† Not a JEDEC symbol.

### 5-V switch

PARAMETER		TEST CONDITIONS	MIN	TYP	MAX	UNIT
$V_{IT}(\text{high})$	Threshold voltage†		4.2		4.9	V
$V_{IT}(\text{low})$			4.1		4.8	
$V_{hsy}$	Hysteresis)		50	150	250	mV

† Not a JEDEC symbol.

### UVLO

PARAMETER		TEST CONDITIONS	MIN	TYP	MAX	UNIT
$V_{IT}(\text{high})$	Threshold voltage†		3.6		4.2	V
$V_{IT}(\text{low})$			3.5		4.1	
$V_{hys}$	Hysteresis		10		150	mV

† Not a JEDEC symbol.

### output

PARAMETER		TEST CONDITIONS	MIN	TYP	MAX	UNIT
$I_O$	OUT_u sink current	$V_O = 3\text{ V}$	0.5	1.2		A
$I_S$	OUT_u source current	$V_O = 2\text{ V}$	-1	-1.7		A
$I_O$	OUT_d sink current	$V_O = 3\text{ V}$	0.5	1.2		A
$I_S$	OUT_d source current	$V_O = 2\text{ V}$	-1	-1.5		A
$I$	TRIP terminal current	PWM mode, $V_{TRIP} = 7\text{ V}$	10	15	20	$\mu\text{A}$
		SKIP mode, $V_{TRIP} = 7\text{ V}$	3	5	7	
$t_r$	Rise time	High side driver is GND referenced.				ns
		Input: INV = 0 – 3V				
		$t_r/t_f = 10\text{ ns}, \text{ Frequency} = 200\text{ kHz}$				
		$C_L = 2200\text{ pF}$		28		
		$C_L = 3300\text{ pF}$		39		
$t_f$	Fall time	High side driver is GND referenced.				ns
		Input: INV = 0 – 3V				
		$t_r/t_f = 10\text{ ns}, \text{ Frequency} = 200\text{ kHz}$				
		$C_L = 2200\text{ pF}$		30		
		$C_L = 3300\text{ pF}$		38		



# TPS5103 MULTIPLE MODE SYNCHRONOUS DC/DC CONTROLLER

SLVS240 – SEPTEMBER 1999

electrical characteristics over recommended operating free-air temperature range,  $V_{CC} = 7\text{ V}$   
(unless otherwise noted) (continued)

### softstart

PARAMETER		TEST CONDITIONS	MIN	TYP	MAX	UNIT
$I_{CTRL}$	Softstart current		1.9	2.5	3	$\mu\text{A}$
$V_{IT(high)}$	Threshold voltage (SKIP mode) <sup>†</sup>			3.9		V
$V_{IT(low)}$				2.6		

<sup>†</sup> Not a JEDEC symbol.

### output voltage monitor

PARAMETER		TEST CONDITIONS	MIN	TYP	MAX	UNIT
$V_{IT}$	Threshold voltage		1.08	1.18	1.28	V

### driver deadtime section

PARAMETER		TEST CONDITIONS	MIN	TYP	MAX	UNIT
$T_{DRV LH}$	Low-side to high-side			90		ns
$T_{DRV HL}$	High-side to low-side			110		ns

### whole device

PARAMETER		TEST CONDITIONS	MIN	TYP	MAX	UNIT
$I_{CC}$	Supply current			0.5	1.2	mA
$I$	Shutdown current	STBY = 0 V		0.01	10	$\mu\text{A}$

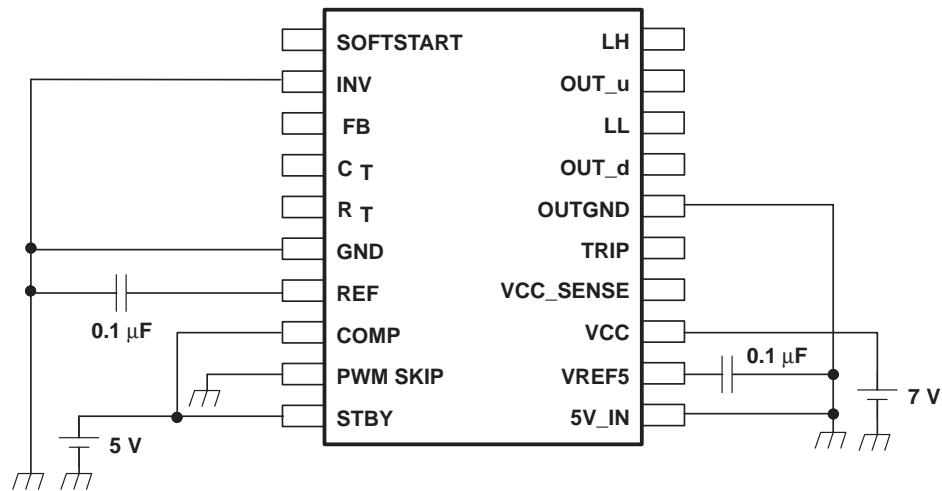

Figure 2. Test Circuit

# TPS5103 MULTIPLE MODE SYNCHRONOUS DC/DC CONTROLLER

SLVS240 – SEPTEMBER 1999

## TYPICAL CHARACTERISTICS

QUIESCENT CURRENT  
vs  
JUNCTION TEMPERATURE

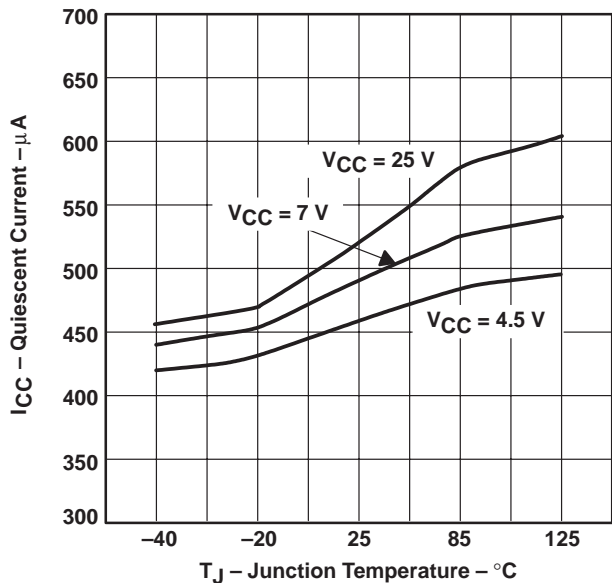

Figure 3

QUIESCENT CURRENT  
vs  
JUNCTION TEMPERATURE

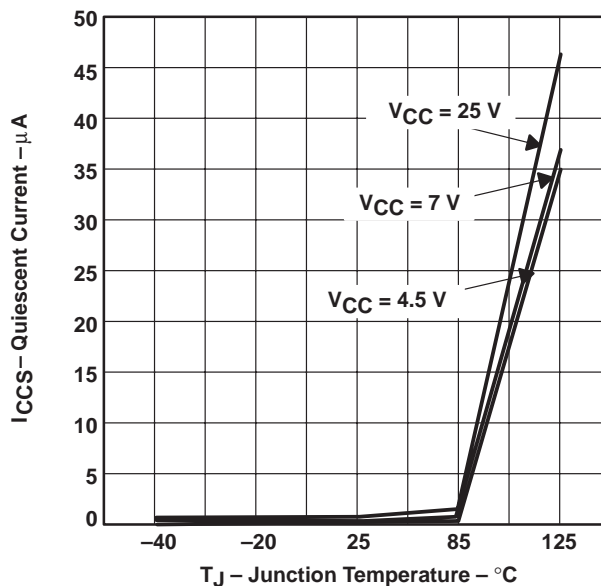

Figure 4

DRIVE OUTPUT VOLTAGE  
vs  
DRIVE CURRENT

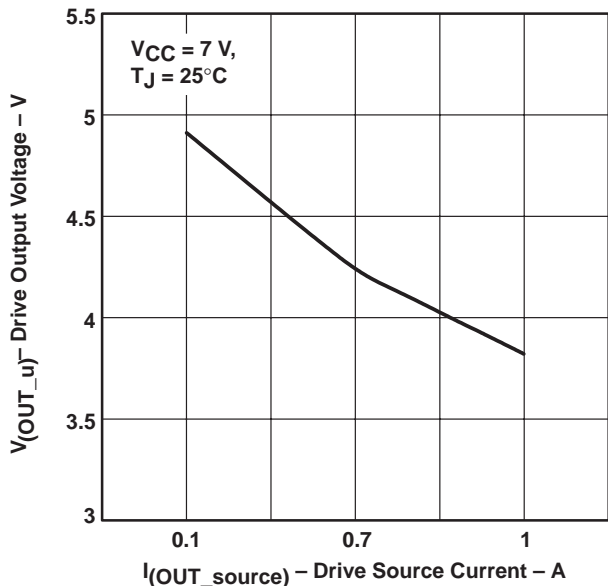

Figure 5

DRIVE OUTPUT VOLTAGE  
vs  
DRIVE CURRENT

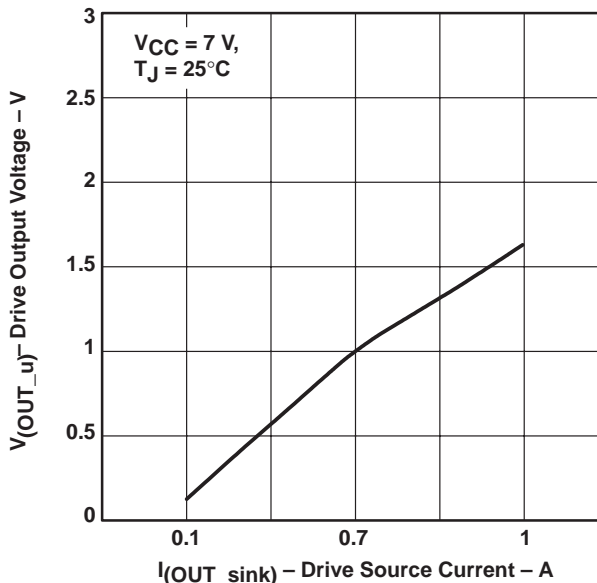

Figure 6

TYPICAL CHARACTERISTICS

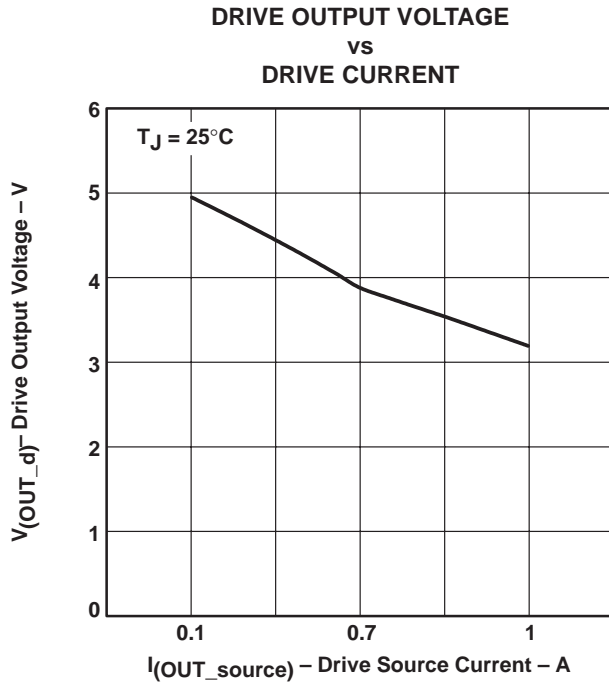

Figure 7

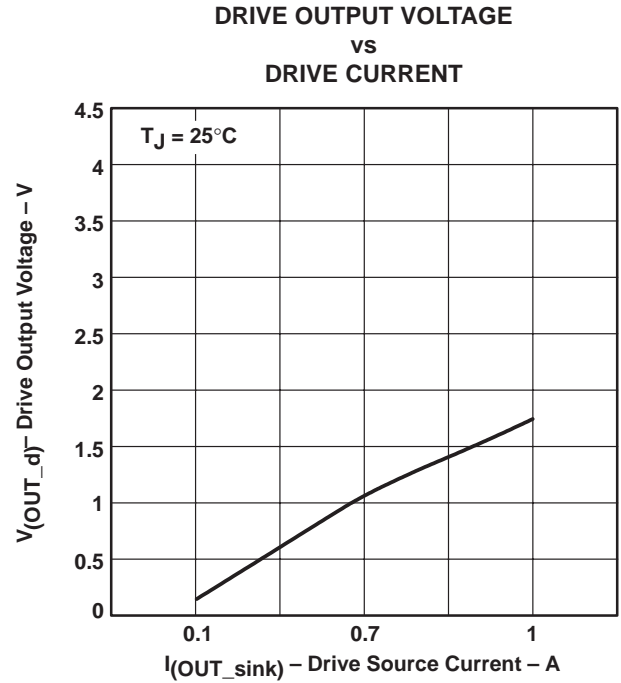

Figure 8

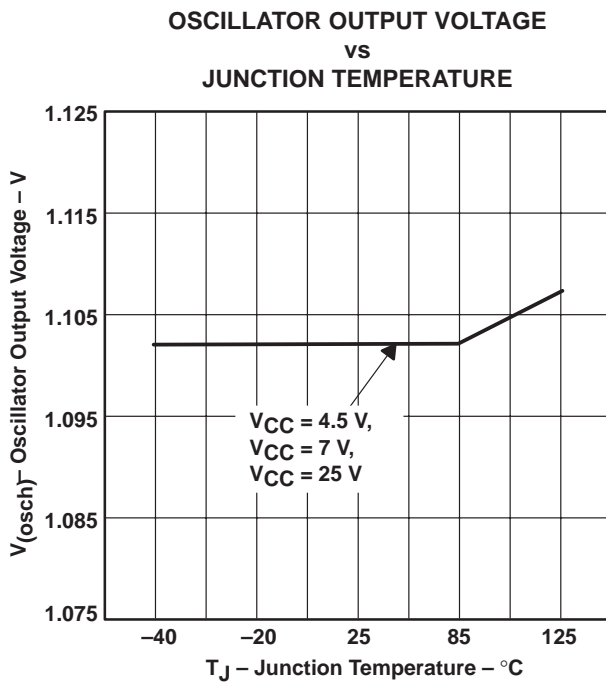

Figure 9

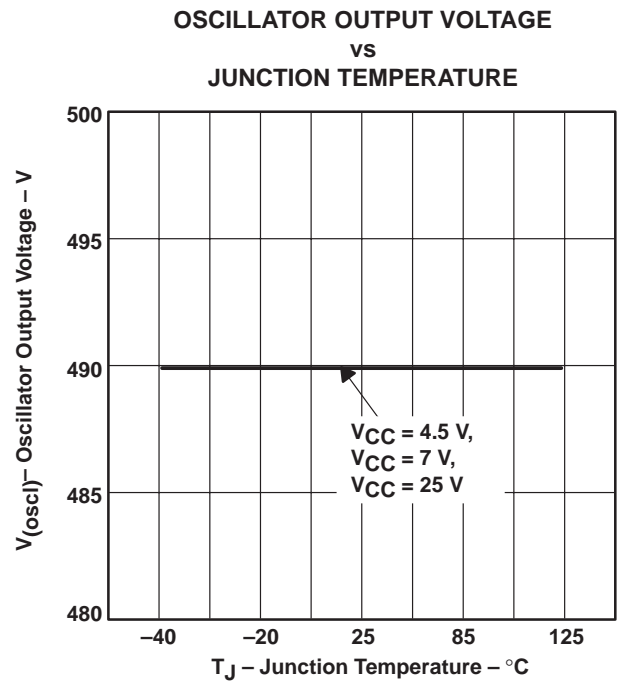

Figure 10

# TPS5103 MULTIPLE MODE SYNCHRONOUS DC/DC CONTROLLER

SLVS240 – SEPTEMBER 1999

## TYPICAL CHARACTERISTICS

ERROR AMPLIFIER INPUT OFFSET VOLTAGE  
VS  
JUNCTION TEMPERATURE

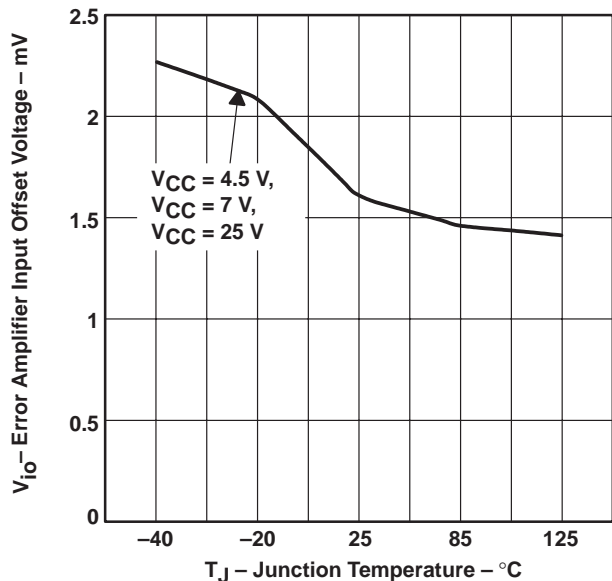

Figure 11

ERROR AMPLIFIER OUTPUT VOLTAGE  
VS  
JUNCTION TEMPERATURE

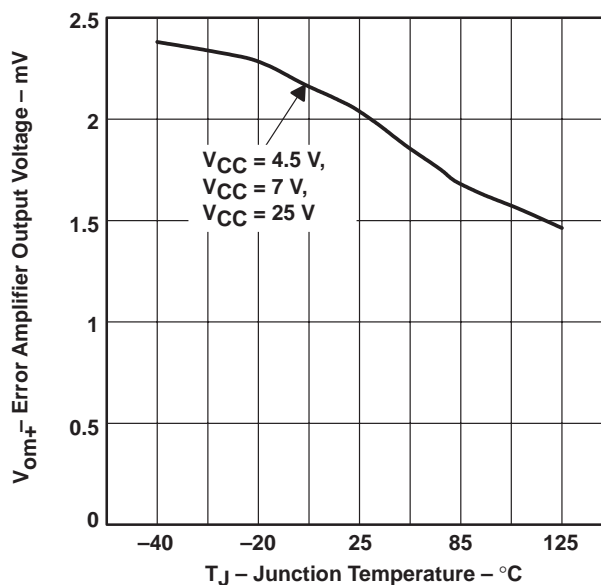

Figure 12

ERROR AMPLIFIER OUTPUT VOLTAGE  
VS  
JUNCTION TEMPERATURE

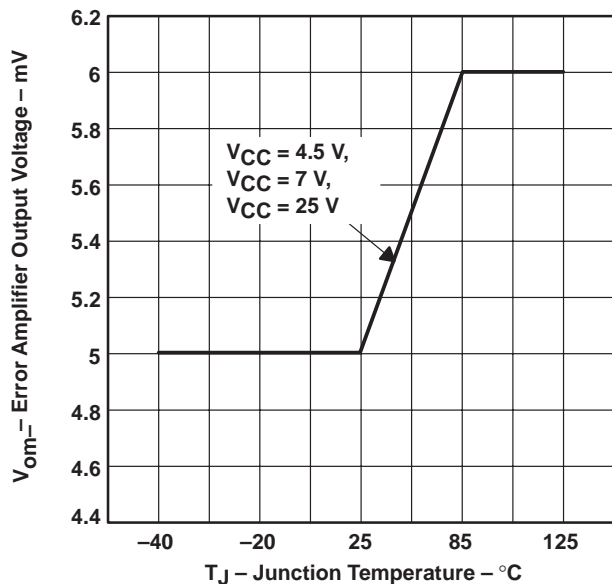

Figure 13

HYSTERESIS COMPARATOR HYSTERESIS VOLTAGE  
VS  
JUNCTION TEMPERATURE

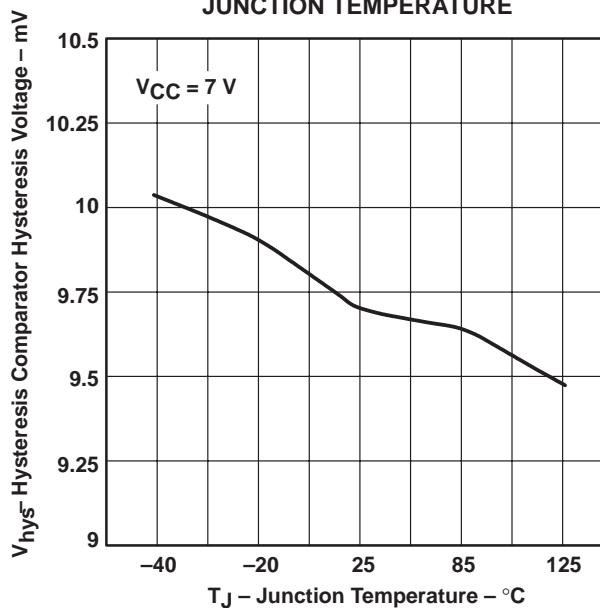

Figure 14

TYPICAL CHARACTERISTICS

STANDBY SWITCH THRESHOLD VOLTAGE  
 VS  
 JUNCTION TEMPERATURE

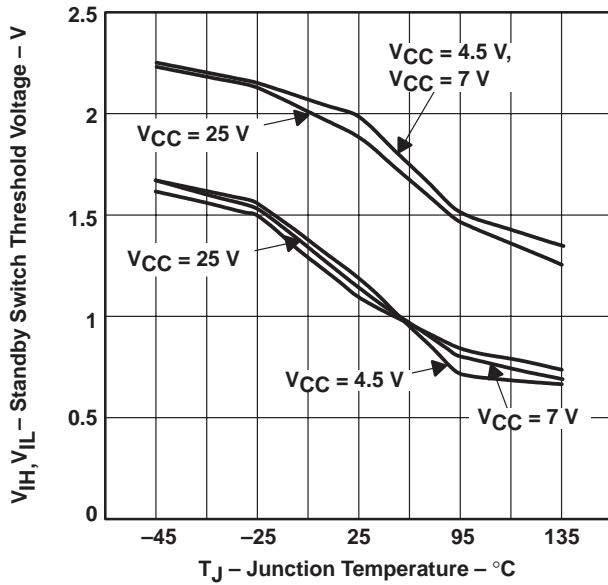

Figure 15

VREF5 OUTPUT VOLTAGE  
 VS  
 SUPPLY VOLTAGE

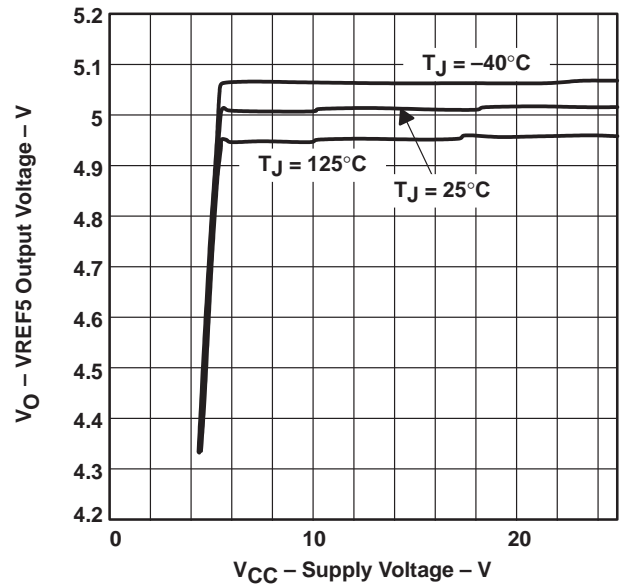

Figure 16

VREF5 OUTPUT VOLTAGE  
 VS  
 OUTPUT CURRENT

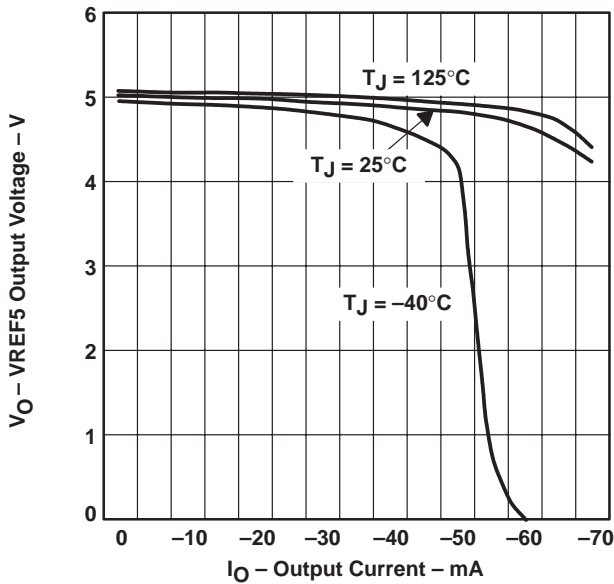

Figure 17

VREF5 SHORT CURRENT  
 VS  
 JUNCTION TEMPERATURE

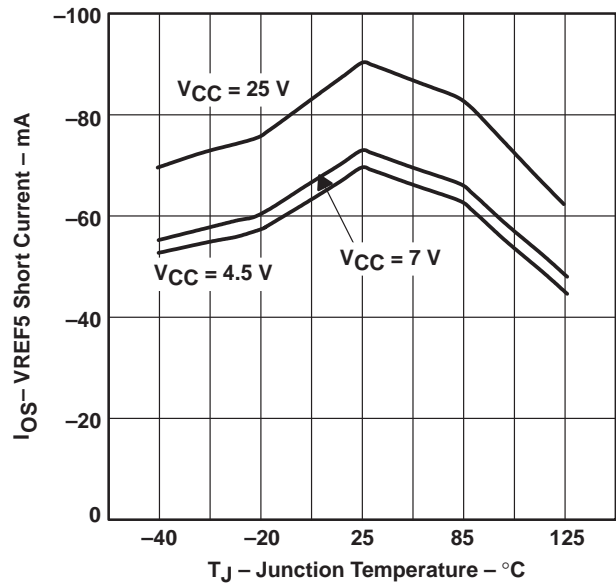

Figure 18

# TPS5103 MULTIPLE MODE SYNCHRONOUS DC/DC CONTROLLER

SLVS240 – SEPTEMBER 1999

## TYPICAL CHARACTERISTICS

UVLO THRESHOLD VOLTAGE  
vs  
JUNCTION TEMPERATURE

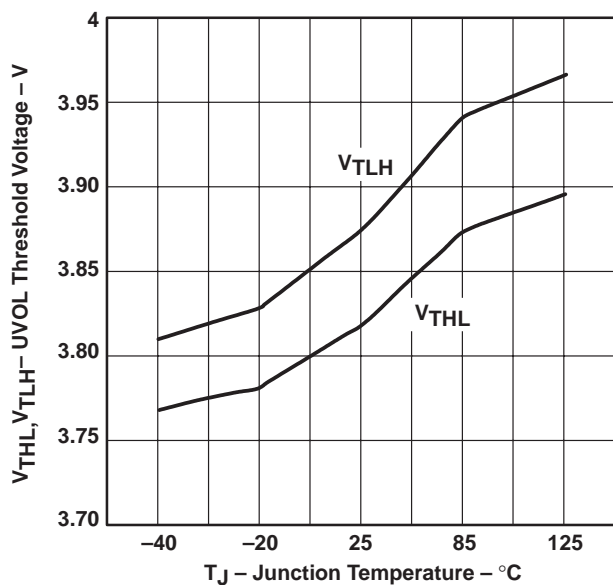

Figure 19

UVLO HYSTERESIS VOLTAGE  
vs  
JUNCTION TEMPERATURE

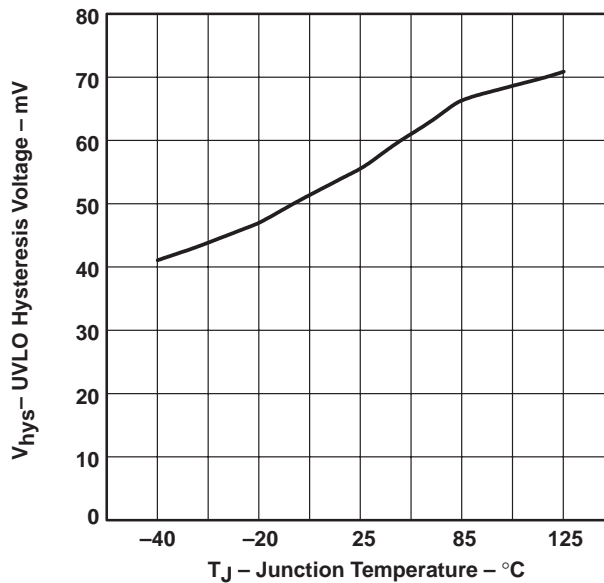

Figure 20

5 VSW THRESHOLD VOLTAGE  
vs  
JUNCTION TEMPERATURE

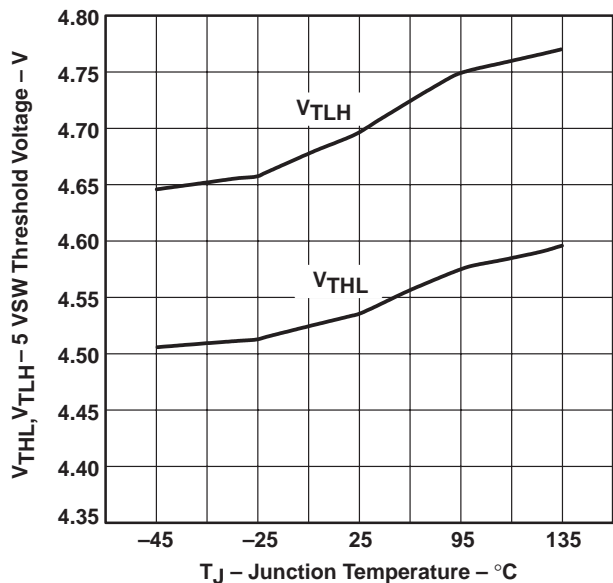

Figure 21

5 VSW HYSTERESIS VOLTAGE  
vs  
JUNCTION TEMPERATURE

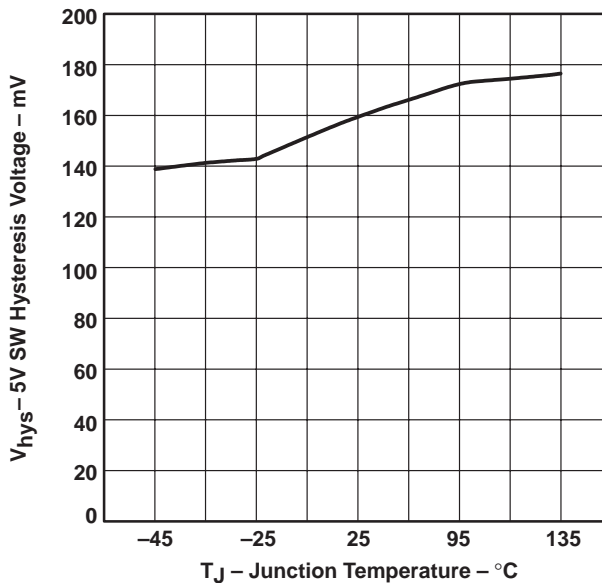

Figure 22

TYPICAL CHARACTERISTICS

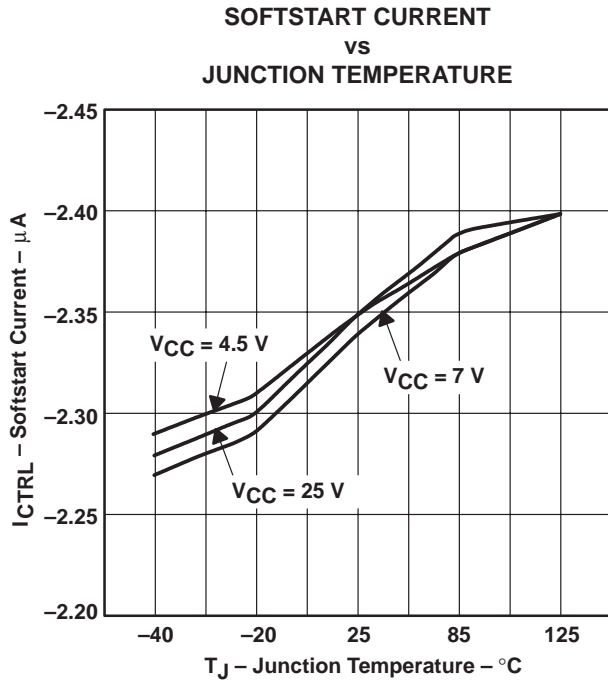

Figure 23

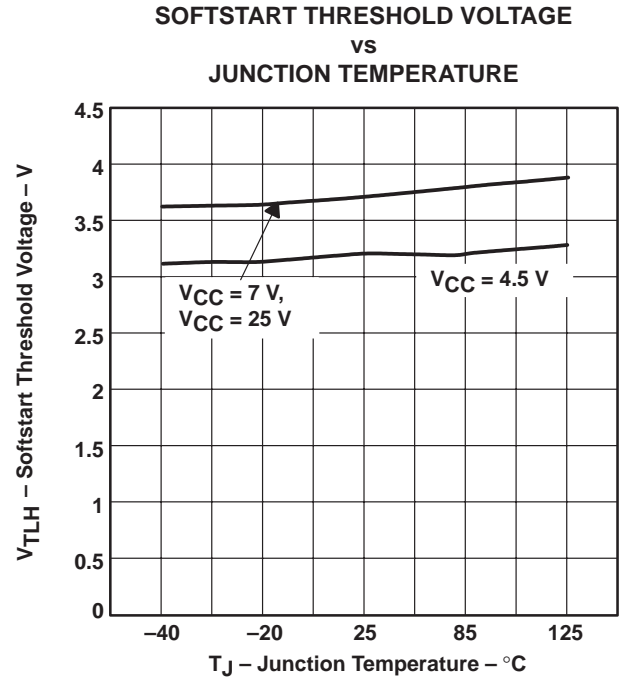

Figure 24

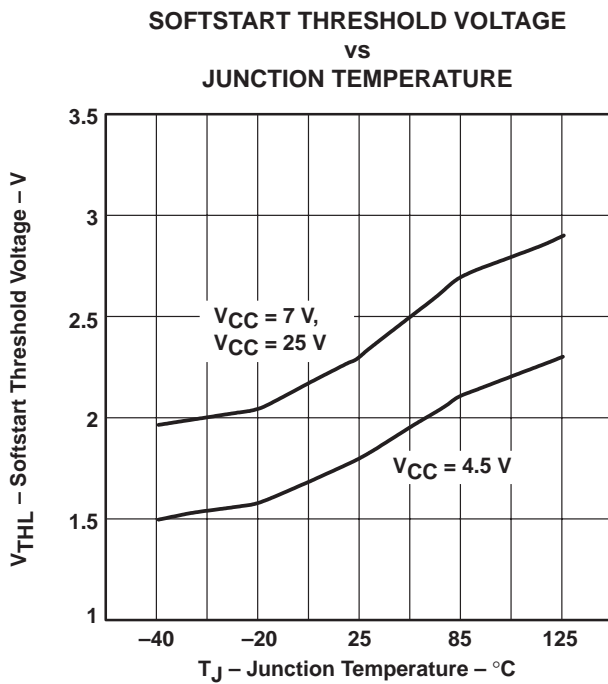

Figure 25

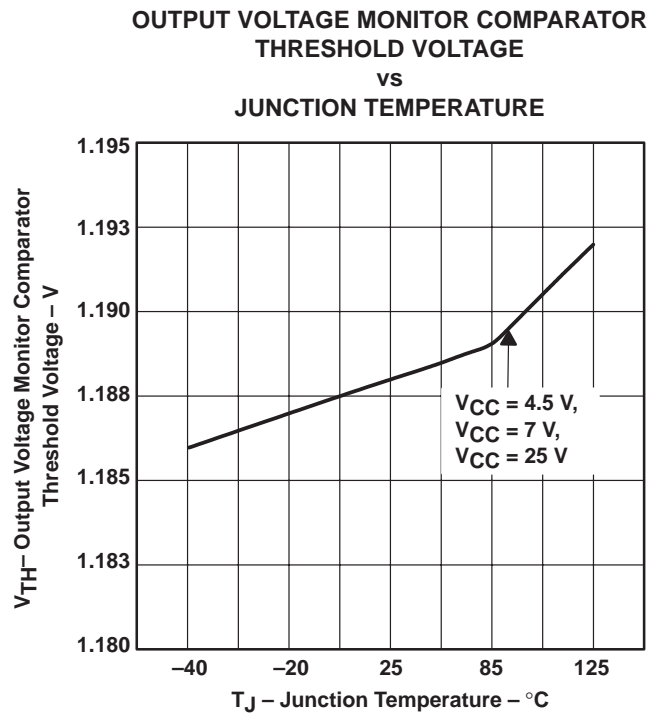

Figure 26

# TPS5103 MULTIPLE MODE SYNCHRONOUS DC/DC CONTROLLER

SLVS240 – SEPTEMBER 1999

## TYPICAL CHARACTERISTICS

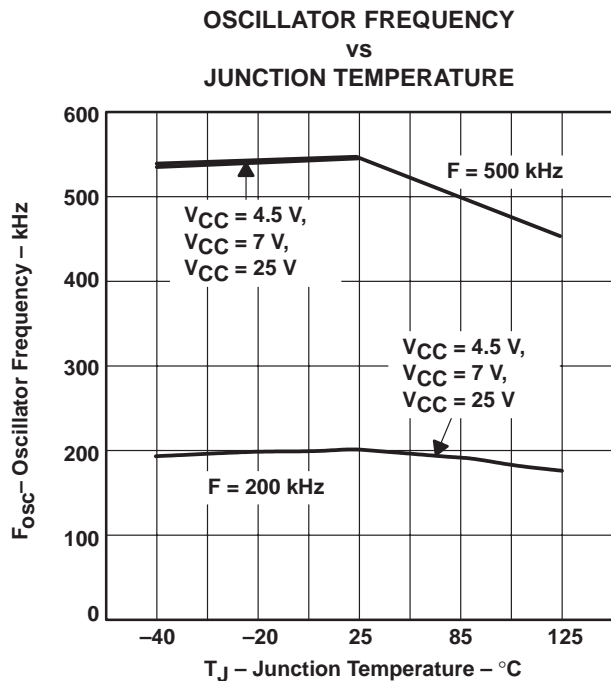

Figure 27

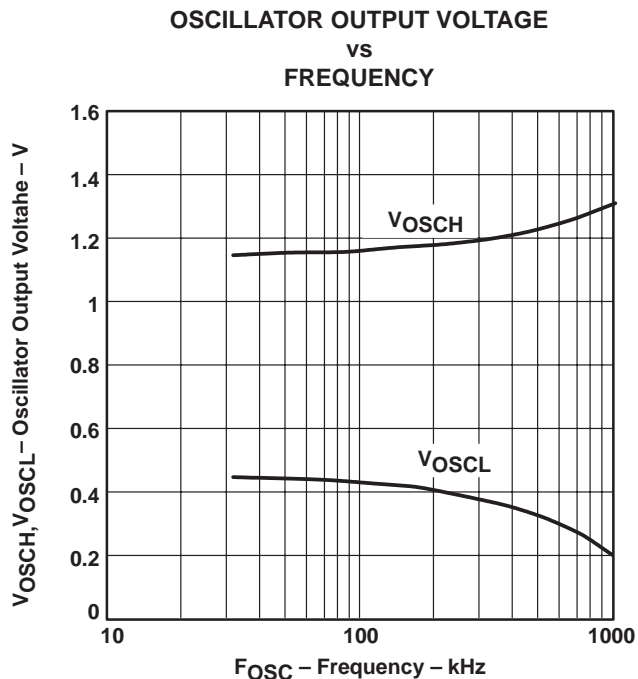

Figure 28

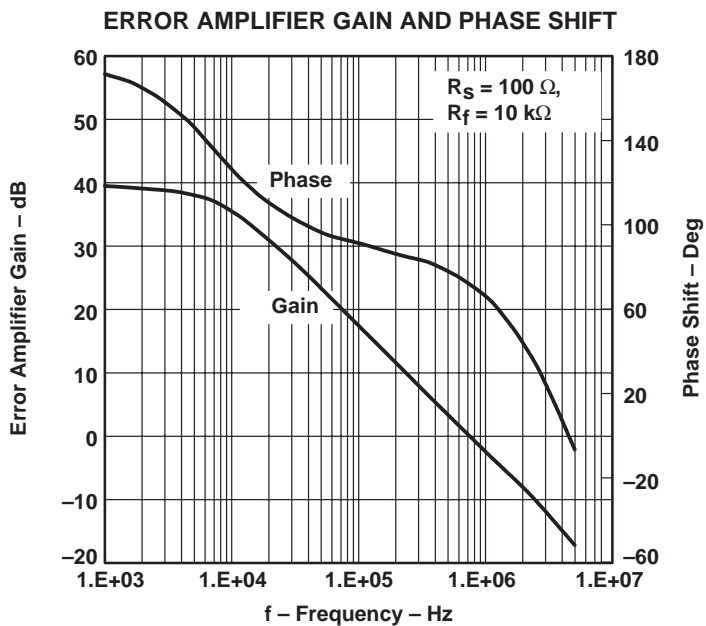

Figure 29



TYPICAL CHARACTERISTICS

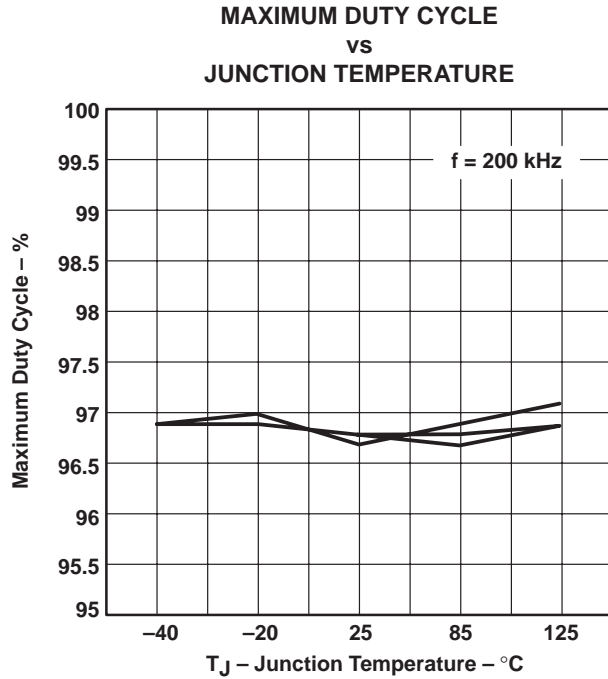

Figure 30

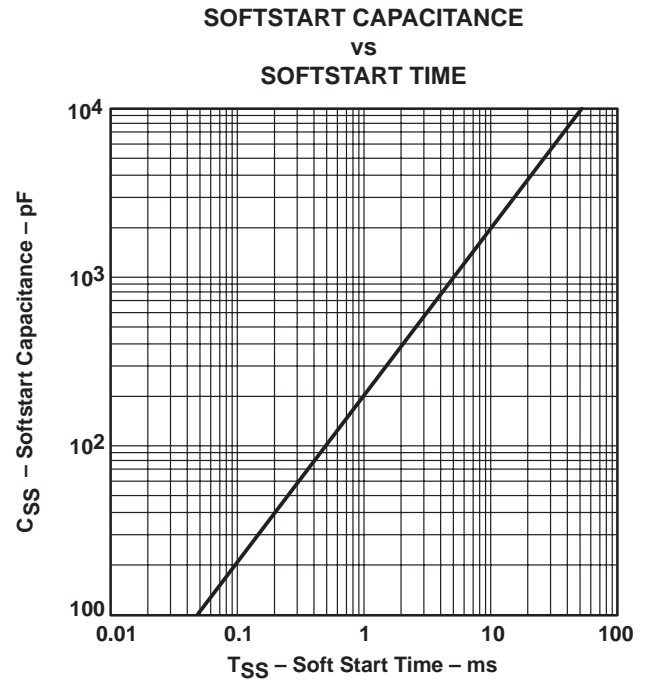

Figure 31

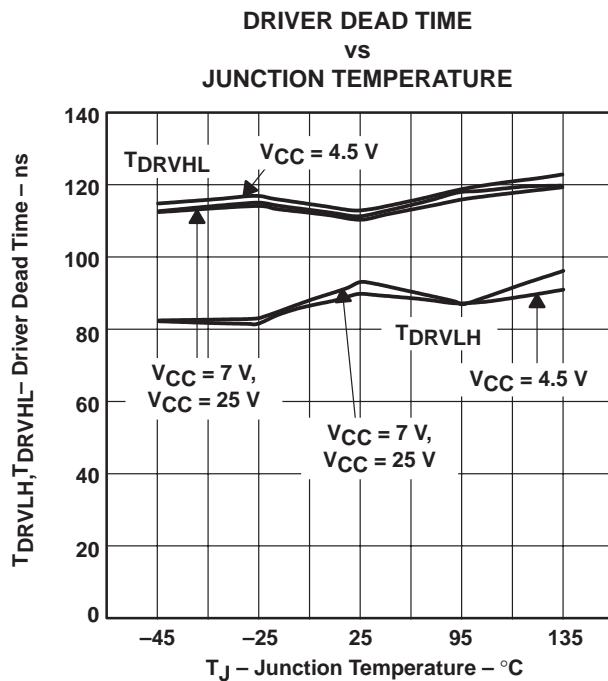

Figure 32

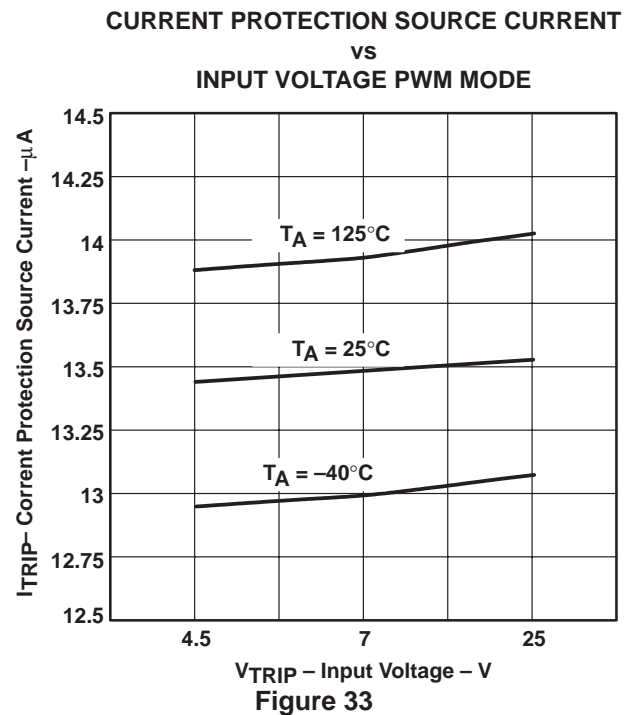

Figure 33

# TPS5103 MULTIPLE MODE SYNCHRONOUS DC/DC CONTROLLER

SLVS240 – SEPTEMBER 1999

## TYPICAL CHARACTERISTICS

CURRENT PROTECTION SOURCE CURRENT  
vs  
INPUT VOLTAGE SKIP MODE

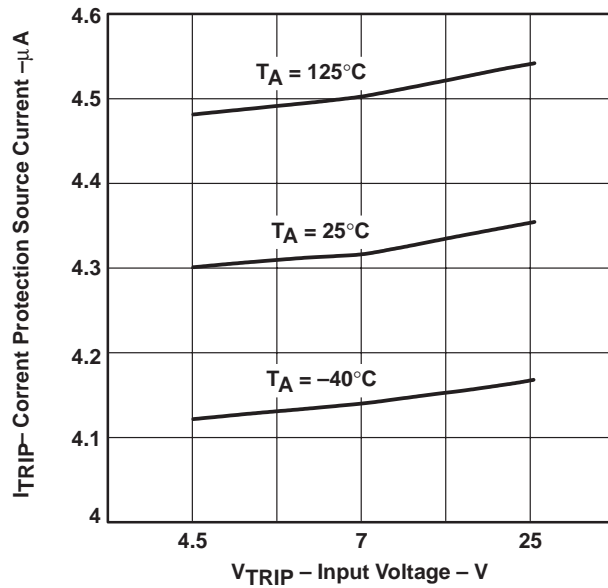

Figure 34

OSCILLATOR FREQUENCY  
vs  
RESISTOR

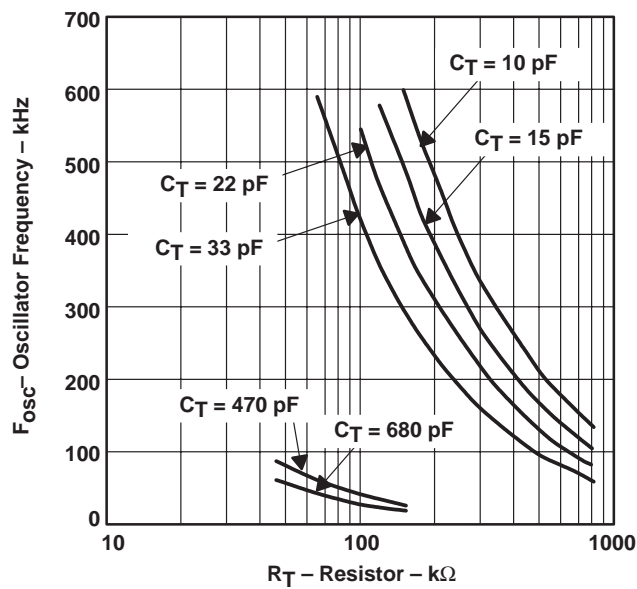
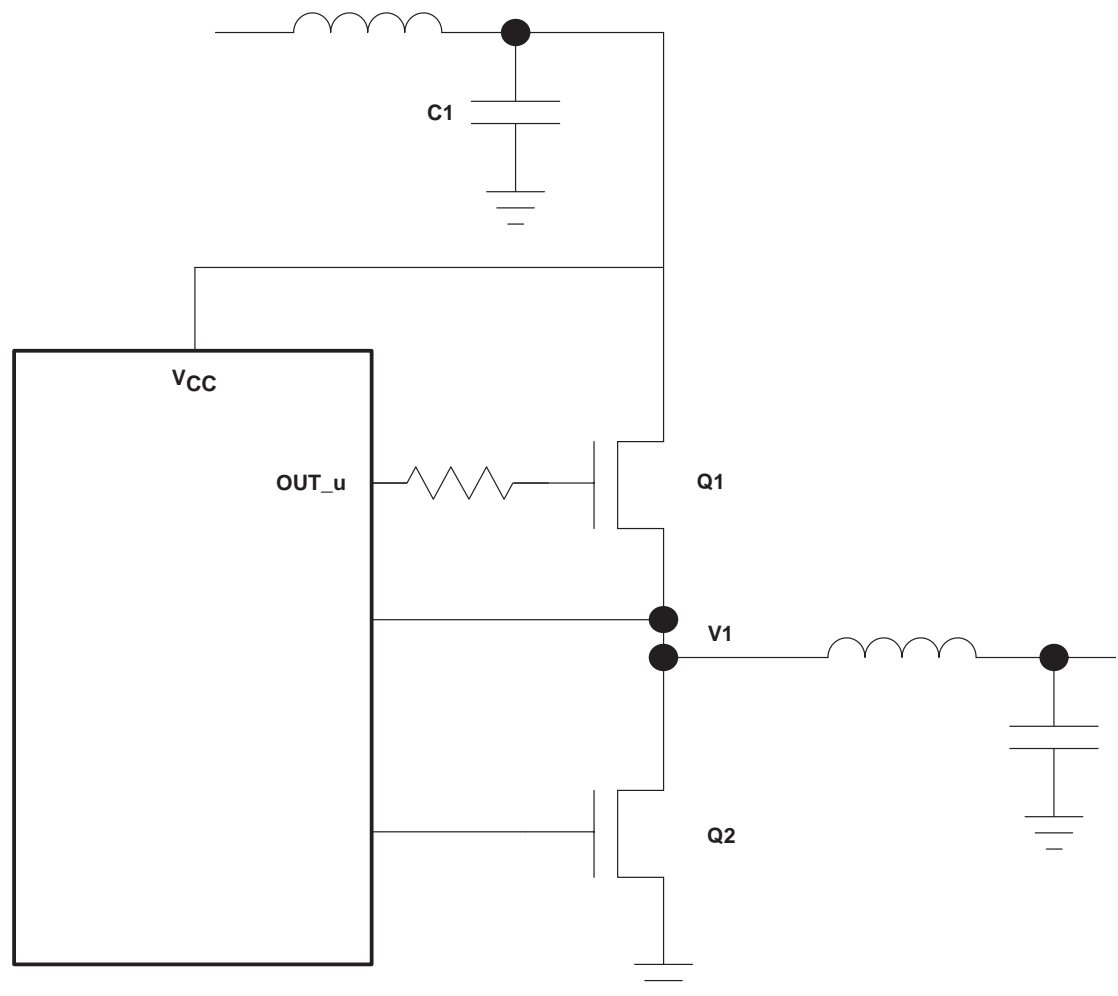

Figure 35

APPLICATION INFORMATION

overshoot of output rectangle wave

The drivers in the TPS5103 controller are fast and can produce high transients on  $V_{CC}$  or the junction of Q1 and Q2 (shown below). Care must be taken to insure that these transients do not exceed the absolute maximum rating for the device or associated external component. A low-ESR capacitor connected directly from Q1 drain to Q2 source can greatly reduce transient pulses on  $V_{CC}$ . Also, Q1 turn-on-speed can be reduced by adding a resistor (5 – 15  $\Omega$ ) in series with OUT\_u. Poor layout of the switching node (V1 in figure) can result in the requirement for additional snubber circuitry require from V1 to ground.



# TPS5103 MULTIPLE MODE SYNCHRONOUS DC/DC CONTROLLER

SLVS240 – SEPTEMBER 1999

## APPLICATION INFORMATION

### application for general power

The design shown in this data sheet is a reference design for a general power supply application. An evaluation module (EVM), TPS5103EVM-136 (SLVP136), is available for customer testing and evaluation. The intent is to allow a customer to fully evaluate the given design using the plug-in EVM supply shown here. For subsequent customer board revisions, the EVM design can be copied onto the users PCB to shorten design cycle time, component count, and board cost.

To help the customers to design the power supply using TPS5103, some key design procedures are shown below.

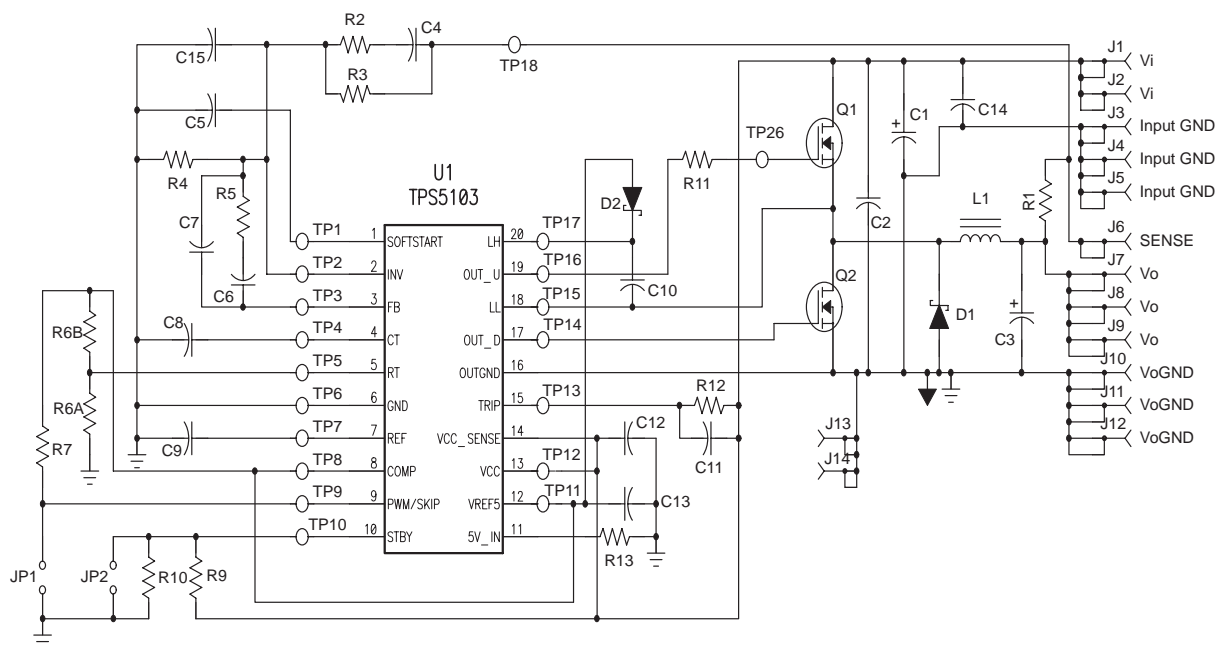

Figure 36. EVM Schematic

## APPLICATION INFORMATION

### output voltage setpoint calculation

The output voltage is set by the reference voltage and the voltage divider. In TPS5102, the reference voltage is 1.185 V, and the divider is composed of two resistors in the EVM design that are R4 and R5, or R14 and R15. The equation for the setpoint is:

$$R2 = \frac{R1 \times Vr}{Vo - Vr}$$

Where R1 is the top resistor (kΩ) like R4 or R15; R2 is the bottom resistor (kΩ) such as R5 or R14; Vo is the required output voltage (V); Vr is the reference voltage (1.185 V in TPS5103).

Example: R1 = 1 kΩ; Vr = 1.185 V; Vo = 1.8 V, then R2 = 1.9 kΩ.

For your convenience, some of the most popular output voltage setpoints are calculated in the table below:

Vo	1.3 V	1.5 V	1.8 V	2.5 V	3.3 V	5.0 V
R1 (top) (kΩ)	1	1	1	1	1	1
R2 (bottom) (kΩ)	10	3.7	1.9	0.9	0.56	0.31

If higher precision resistor is used, the output voltage setpoint can be more accurate.

In some applications, the output voltage is required to be lower than the reference voltage. With few extra components, the lower voltage can be easily achieved. The drawing below shows the method.

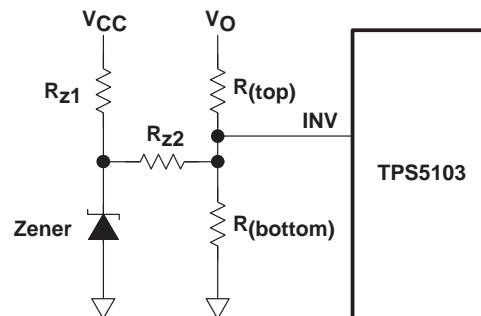

In the schematic, the Rz1, Rz1, and the zener are the extra components. Rz1 is used to give zener enough current to build up the zener voltage. The zener voltage is added to INV through Rz2. Therefore, the voltage on INV is still equal to the IC internal voltage (1.185 V) even if the output voltage is regulated at lower setpoint. The equation for setting up the output voltage is shown below:

$$Rz2 = \frac{(Vz - Vr)}{\frac{(Vr - Vo)}{Rtop} + \frac{Vr}{Rbtm}}$$

Where Rz2 is the adjusting resistor for low output voltage; Vz is the zener voltage; Vr is the internal reference voltage; Rtop is the top resistor of voltage sensing network; Rbtm is the bottom resistor of the sensing network; Vo is the required output voltage setpoint.

Example: Assuming the required output voltage setpoint is Vo = 0.8 V, Vz = 5 V; Rtop = 1 kΩ; Rbottom = 1 kΩ, then the Rz2 = 2.43 kΩ.

# TPS5103

## MULTIPLE MODE SYNCHRONOUS DC/DC CONTROLLER

SLVS240 – SEPTEMBER 1999

### APPLICATION INFORMATION

#### switching frequency

With hysteretic control, the switching frequency is a function of the input voltage, the output voltage, the hysteresis window, the delay of the hysteresis comparator and the driver, the output inductance, the resistance in the output inductor, the output capacitance, the ESR and ESL in the output capacitor, the output current, and the turnon resistance of high side and low side MOSFET. It is a very complex equation if everything is included. To make it more useful to the designers, a simplified equation only considers the most influential factors. The tolerance of this equation is about 30%:

$$f_s = \frac{V_{out} \times (V_{in} - V_{out}) \times (ESR + (10 \times 10^{-7} + T_d)/C_{out})}{V_{in} \times (V_{in} \times ESR \times (10 \times 10^{-7} + T_d) + 0.0097 \times L_{out} - ESL \times V_{in})}$$

Where  $f_s$  is the switching frequency (Hz);  $V_{out}$  is the output voltage (V);  $V_{in}$  is the input voltage (V);  $C_{out}$  is the output capacitance;  $ESR$  is the equivalent series resistance in the output capacitor ( $\Omega$ );  $ESL$  is the equivalent series inductance in the output capacitor (H);  $L_{out}$  is the output inductance (H);  $T_d$  is output feedback RC filter time constant (S).

In the EVM module design, for the 1.8 V output, for example:  $V_{in} = 5$  V,  $V_{out} = 1.8$  V,  $C_{out} = 680$   $\mu$ F;  $ESR = 40$  m $\Omega$ ;  $ESL = 3$  nH;  $L_{out} = 6$   $\mu$ H;  $T_d = 0.5$   $\mu$ s.

Then, the frequency  $f_s = 122$  kHz.

#### output inductor ripple current

The output inductor current ripple can affect not only the efficiency and the inductor saturation, but also the output voltage capacitor selection. The equation is exhibited as below:

$$I_{ripple} = \frac{V_{in} - V_{out} - I_{out} \times (R_{dson} + R_L)}{L_{out}} \times D \times T_s$$

Where  $I_{ripple}$  is the peak-to-peak ripple current (A) through inductor;  $V_{in}$  is the input voltage (V);  $V_{out}$  is the output voltage (V);  $I_{out}$  is the output current;  $R_{dson}$  is the on-time resistance of MOSFET ( $\Omega$ );  $D$  is the duty cycle; and  $T_s$  is the switching cycle (S). From the equation, it can be seen that the current ripple can be adjusted by changing the output inductor value.

Example:  $V_{in} = 5$  V;  $V_{out} = 1.8$  V;  $I_{out} = 5$  A;  $R_{dson} = 10$  m $\Omega$ ;  $R_L = 5$  m $\Omega$ ;  $D = 0.36$ ;  $T_s = 10$   $\mu$ s;  $L_{out} = 6$   $\mu$ H

Then, the ripple  $I_{ripple} = 2$  A.

#### output capacitor RMS current

Assuming the inductor ripple current totally goes through the output capacitor to the ground, the RMS current in the output capacitor can be calculated as:

$$I_{O(rms)} = \frac{\Delta I}{\sqrt{12}}$$

Where  $I_{O(rms)}$  is the maximum RMS current in the output capacitor (A);  $\Delta I$  is the peak-to-peak inductor ripple current (A).

Example:  $\Delta I = 2$  A, so  $I_{O(rms)} = 0.58$  A

## APPLICATION INFORMATION

### input capacitor RMS current

Assuming the input ripple current totally goes into the input capacitor to the power ground, the RMS current in the input capacitor can be calculated as:

$$I_i(\text{rms}) = \sqrt{I_o^2 \times D \times (1 - D) + \frac{1}{12} \times D \times I_{\text{ripple}}^2}$$

Where  $I_i(\text{rms})$  is the input RMS current in the input capacitor (A);  $I_o$  is the output current (A);  $D$  is the duty cycle. From the equation, it can be seen that the highest input RMS current usually occurs at the lowest input voltage, so it is the worst case design for input capacitor ripple current.

Example:  $I_o = 5 \text{ A}$ ;  $D = 0.36$

Then,  $I_i(\text{rms}) = 3.36 \text{ A}$

### softstart

The softstart timing can be adjusted by selecting the soft-start capacitor value. The equation is

$$C_{\text{soft}} = 2 \times T_{\text{soft}}$$

Where  $C_{\text{soft}}$  is the softstart capacitance ( $\mu\text{F}$ );  $T_{\text{soft}}$  is the start-up time on softstart terminal (S).

Example:  $T_{\text{soft}} = 5 \text{ mS}$ , so  $C_{\text{soft}} = 0.01 \mu\text{F}$ .

### current protection

The current protection in TPS5103 is set using an internal current source and an external resistor to set up the current limit. The sensed high side MOSFET drain-to-source voltage drop is compared to the set point, if the voltage drop exceeds the limit, the internal oscillator is activated, and it continuously resets the current limit until the over-current condition is removed. The equation below should be used for calculating the external resistor value for current protection:

$$\text{PWM or HYS mode} \quad R_{\text{cl}} = \frac{R_{\text{ds(on)}} \times (I_{\text{trip}} + I_{\text{ind(p-p)}}/2)}{0.000015}$$

$$\text{SKIP mode} \quad R_{\text{cl}} = \frac{R_{\text{ds(on)}} \times (I_{\text{trip}} + I_{\text{ind(p-p)}}/2)}{0.000005}$$

Where  $R_{\text{cl}}$  is the external current limit resistor (R10,R11);  $R_{\text{ds(on)}}$  is the high side MOSFET on-time resistance.  $I_{\text{trip}}$  is the required current limit;  $I_{\text{ind(p-p)}}$  is the peak-to-peak output inductor current.

Example: PWM mode or HYS mode

$$R_{\text{ds(on)}} = 10 \text{ m}\Omega, I_{\text{trip}} = 5 \text{ A}, I_{\text{ind}} = 2 \text{ A}, \text{ so } R_{\text{cl}} = 4 \text{ k}\Omega$$

Example: SKIP mode

$$R_{\text{ds(on)}} = 10 \text{ m}\Omega, I_{\text{trip}} = 2 \text{ A}, I_{\text{ind}} = 1 \text{ A}, \text{ so } R_{\text{cl}} = 5 \text{ k}\Omega$$

# TPS5103 MULTIPLE MODE SYNCHRONOUS DC/DC CONTROLLER

SLVS240 – SEPTEMBER 1999

## APPLICATION INFORMATION

### loop gain compensation

Voltage mode control is used in this controller for the output voltage regulation. To achieve fast, stabilized control, two parts are discussed in this section: the power stage small signal modeling and the compensation circuit design.

For the buck converter, the small signal modeling circuit is shown below:

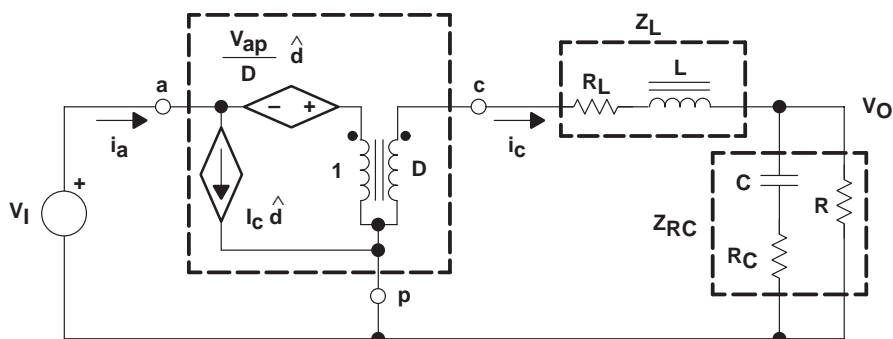

From this equivalent circuit, several control transfer functions can be derived: input-to-output, output impedance, and control-to-output. Typically the control-to-output transfer function is used for the feedback control design.

Assuming  $R_c$  and  $R_L$  are much smaller than  $R$ , the simplified small signal control-to-output transfer function is:

$$\frac{\hat{V}_{od}}{\hat{d}} = \frac{(1 + sCR_c)}{1 + s\left[C \times (R_c + R_L) + \frac{L}{R}\right] + s^2LC}$$

Where  $C$  is the output capacitance;  $R_c$  is the equivalent serial resistance (ESR) in the output capacitor;  $L$  is the output inductor;  $R_L$  is the equivalent serial resistance (ESR) in the output inductor;  $R$  is the load resistance.

To achieve the fast transient response and the better output voltage regulation, a compensation circuit is added to improve the feedback control. The whole system is shown below:

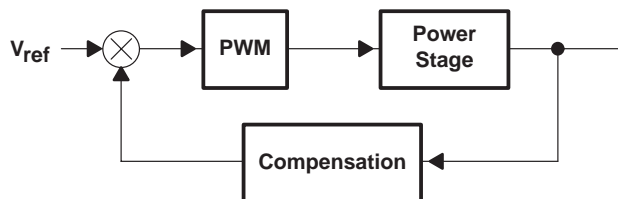



### APPLICATION INFORMATION

The typical compensation circuit used as an option in the EVM design is a part of the output feedback circuit. The circuitry is displayed below.

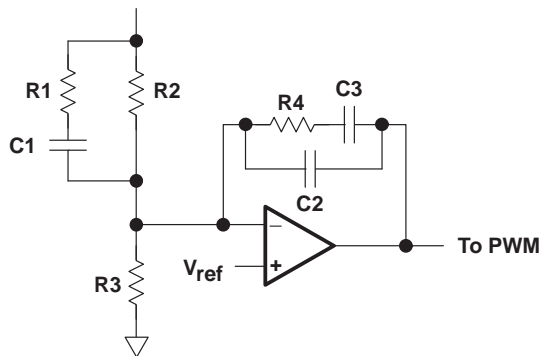

This circuit is composed of one integrator, two poles, and two zeros:

Assuming  $R1 \ll R2$  and  $C2 \ll C3$ , the equation is:

$$\text{Comp} = \frac{(1 + sC3R4) \times (1 + sC2R2)}{sC3R2(1 + sC2R4)(1 + sC1R1)}$$

Therefore,

$$\text{Pole1} = \frac{1}{2\pi C1R1} \quad \text{Pole2} = \frac{1}{2\pi C2R4}$$

$$\text{Zero2} = \frac{1}{2\pi C3R4} \quad \text{Zero1} = \frac{1}{2\pi C2R2}$$

$$\text{Integrator} = \frac{1}{2\pi f C3R2}$$

A simplified version used in the EVM design is exhibited below.

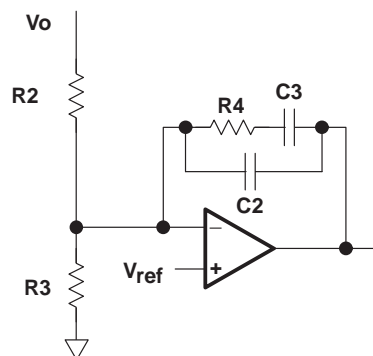

Assuming  $C2 \ll C3$ , the equation is:

$$\text{Comp} = \frac{(1 + sC3R4)}{sC3R2(1 + sC2R4)}$$

# TPS5103 MULTIPLE MODE SYNCHRONOUS DC/DC CONTROLLER

SLVS240 – SEPTEMBER 1999

## APPLICATION INFORMATION

there is one pole, one zero and one integrator:

$$\text{Zero} = \frac{1}{2\pi C3R4} \quad \text{Pole} = \frac{1}{2\pi C2R4} \quad \text{Integrator} = \frac{1}{2\pi f C3R2}$$

The loop-gain concept is used to design a stable and fast feedback control. The loop-gain equation is derived by that the control-to-output transfer function times the compensation:

$$\text{Loop - gain} = \text{Vod} \times \text{Comp}$$

By using a bode plot, the amplitude and the phase of this equation can be drawn with software such as MathCad. In turn, the stability can be easily designed by adjusting the compensation perimeters. The sample bode plot is shown below to explain the phase margin, gain margin and the crossover frequency.

The gain is drawn as 20 log (loop-gain), and the phase is in degrees. To explain them clearer, 180 degrees is added to the phase, so that the gain and phase share the same zero.

Where the gain curve touches the zero is the crossover frequency. The higher this frequency is, the faster the transient response is, since the transient recovery time is 1/(crossover frequency). The phase to the zero is the phase margin at the crossover frequency. The phase margin should be at least 60 degrees to cover all the condition changes such as temperature. The gain margin is the gap between gain curve and the zero when the phase curve touches the zero. This margin should be at least 20 dB to guarantee the stability over all conditions.

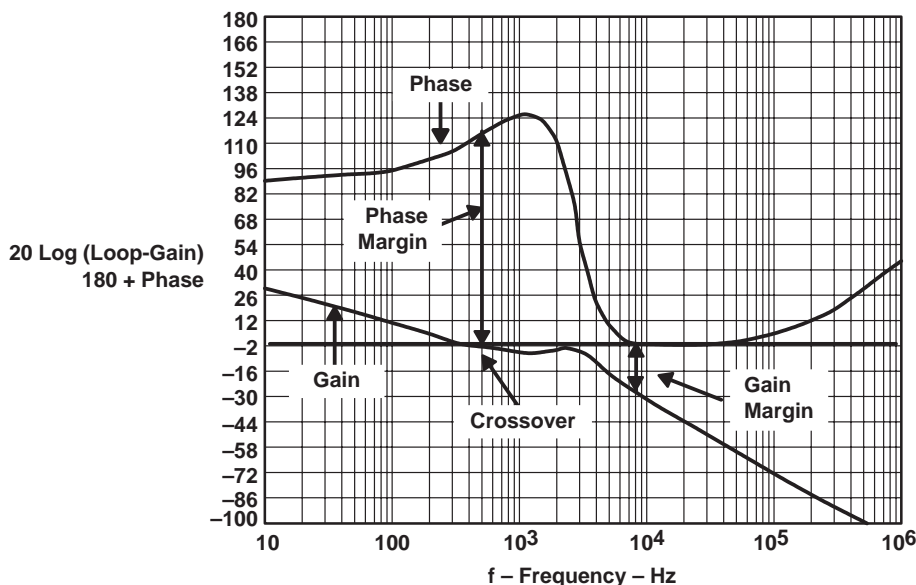

## APPLICATION INFORMATION

### synchronization

Some applications require switching clock synchronization. Two methods are used for synchronization:

- Triangle wave synchronization

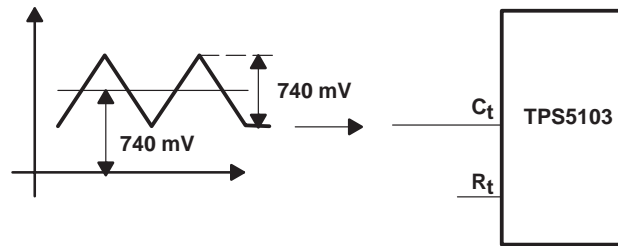

- Square wave synchronization

It can be seen that  $R_T$  and  $C_T$  are removed from the circuit. Therefore, two components are saved. This method is good for the synchronization between two controllers. If the controller needs to be synchronized with digital circuit such as DSP, usually the square-type clock signal is used. The configuration exhibited below is for this type of application:

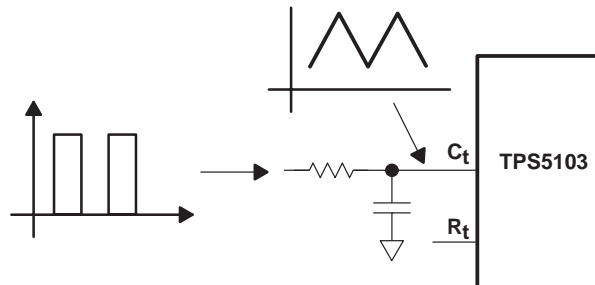

An external resistor is added into the circuit, but  $R_T$  is still removed.  $C_T$  is kept to be a part of RC circuit generating triangle waveform for the controller. Assuming the peak value of the square is known, the resistor and the capacitor can be adjusted to achieve the correct peak-to-peak value and the offset value.

### layout guidelines

Good power supply results will only occur when care is given to proper design and layout. Layout will affect noise pickup and generation and can cause a good design to perform with less than expected results. With a range of currents from milliamps to tens or even hundreds of amps, good power supply layout is much more difficult than most general PCB designs. The general design should proceed from the switching node to the output, then back to the driver section and, finally, place the low-level components. Below are several specific points to consider before layout of a TPS5103 design begins.

- All sensitive analog components should be referenced to ANAGND. These include components connected to  $V_{ref5}$ ,  $V_{ref}$ , INV, LH, and COMP .
- Analog ground and drive ground should be isolated as much as possible. Ideally, analog ground will connect to the ground side of the bulk storage capacitors on  $V_O$ , and drive ground will connect to the main ground plane close to the source of the low-side FET.

# TPS5103

## MULTIPLE MODE SYNCHRONOUS DC/DC CONTROLLER

SLVS240 – SEPTEMBER 1999

---

### APPLICATION INFORMATION

- Connections from the drivers to the gate of the power FETs should be as short and wide as possible to reduce stray inductance. This becomes more critical if external gate resistors are not being used.
- The bypass capacitor for  $V_{CC}$  should be placed close to the TPS5103.
- When configuring the high-side driver as a floating driver, the connection from LL to the power FETs should be as short and as wide as possible.
- When configuring the high-side driver as a floating driver, the bootstrap capacitor (connected from LH to LL) should be placed close to the TPS5103.
- When configuring the high-side driver as a ground-referenced driver, LL should be connected to DRVGND.
- The bulk storage capacitors across  $V_{IN}$  should be placed close to the power FETS. High-frequency bypass capacitors should be placed in parallel with the bulk capacitors and connected close to the drain of the high-side FET and to the source of the low-side FET.
- High-frequency bypass capacitors should be placed across the bulk storage capacitors on  $V_O$ .
- LH and LL should be connected very close to the drain and source, respectively, of the high-side FET. LH and LL should be routed very close to each other to minimize differential-mode noise coupling to these traces. Ceramic decoupling capacitors should be placed close to where  $V_{CC}$  connects to  $V_{in}$ , to reduce high-frequency noise coupling on  $V_{CC}$ .
- The output voltage sensing trace should be isolated by either ground trace or  $V_{CC}$  trace.

### test results

The tests are conducted at  $T_A = 25^\circ\text{C}$ , the point voltage is 5 V.

APPLICATION INFORMATION

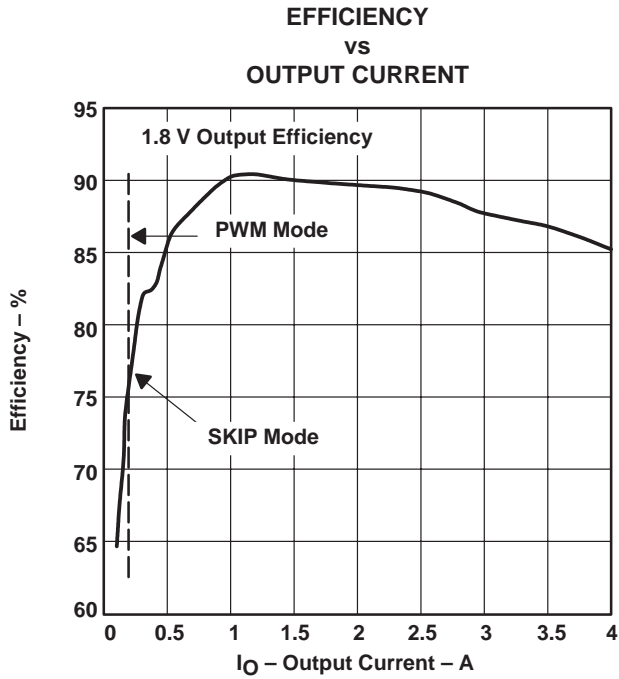

Figure 37

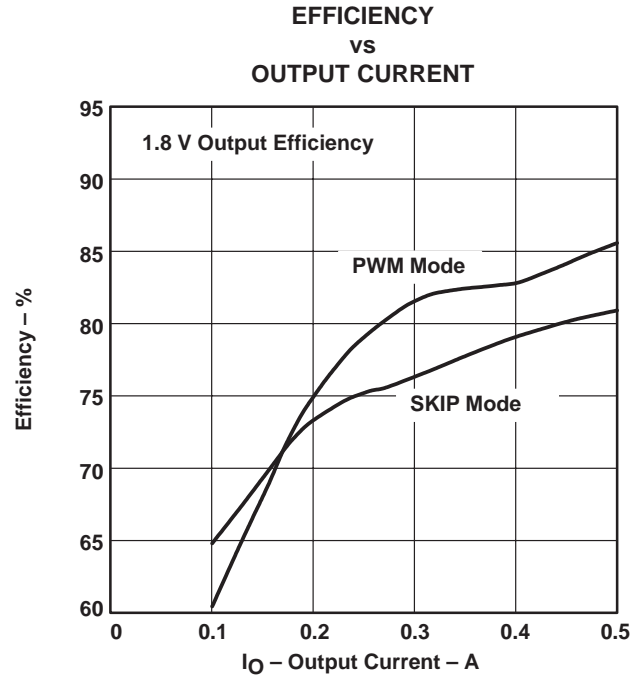

Figure 38

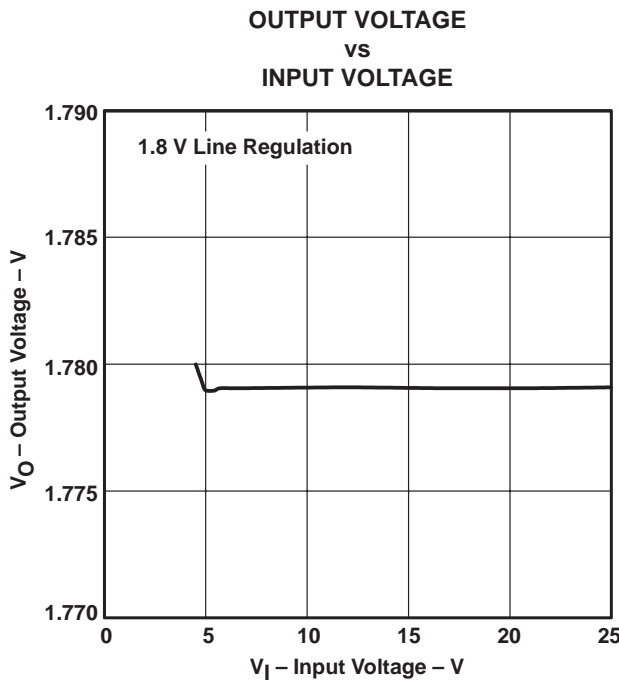

Figure 39

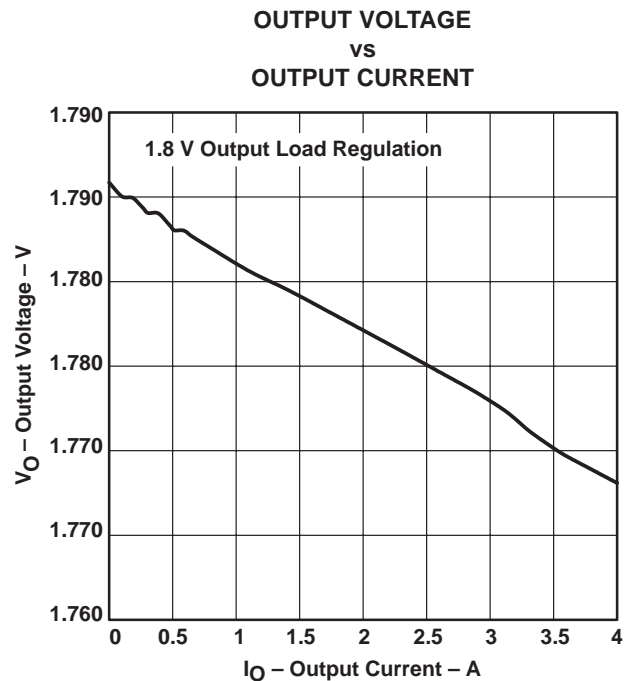

Figure 40

# TPS5103 MULTIPLE MODE SYNCHRONOUS DC/DC CONTROLLER

SLVS240 – SEPTEMBER 1999

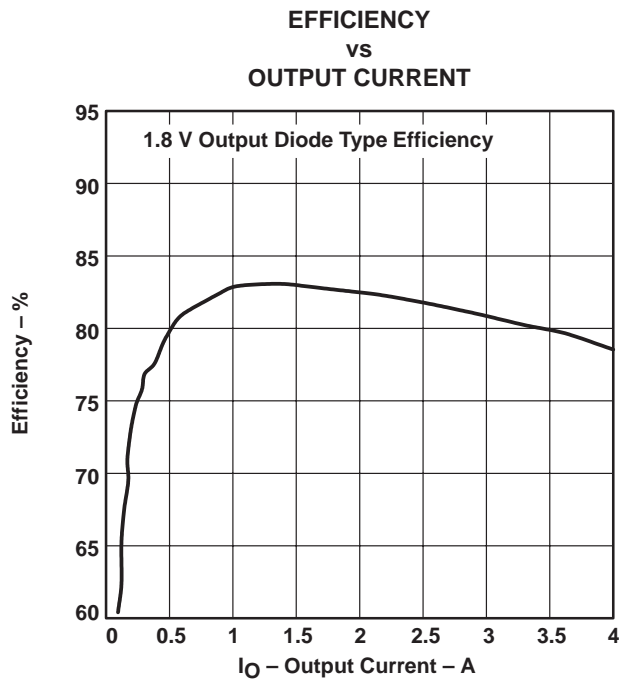

Figure 41

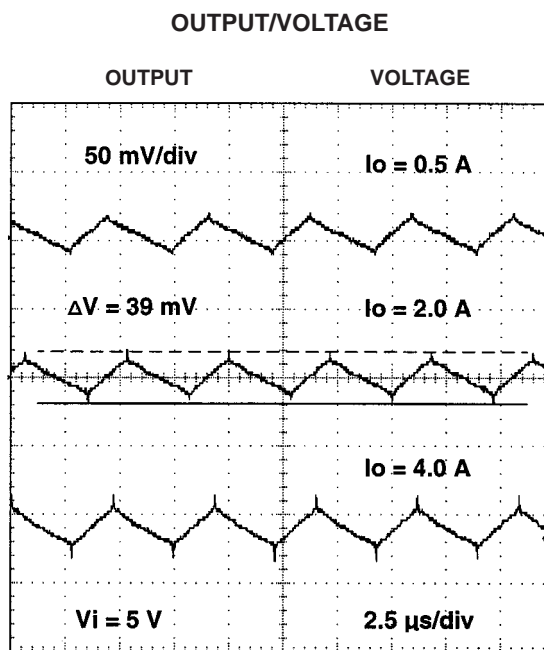

Figure 42

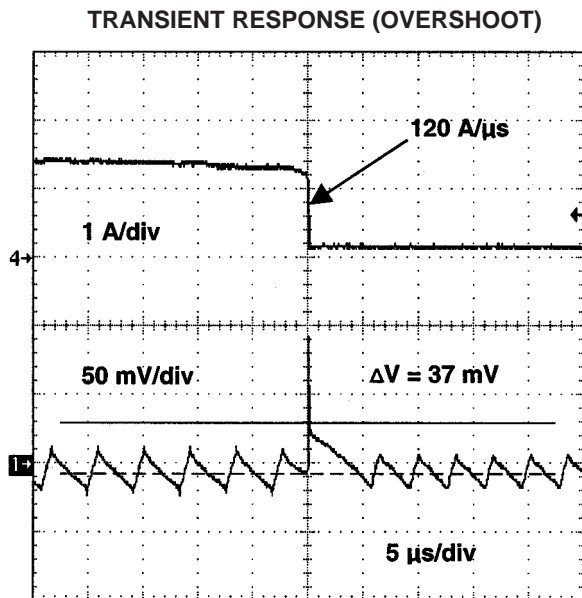

Figure 43

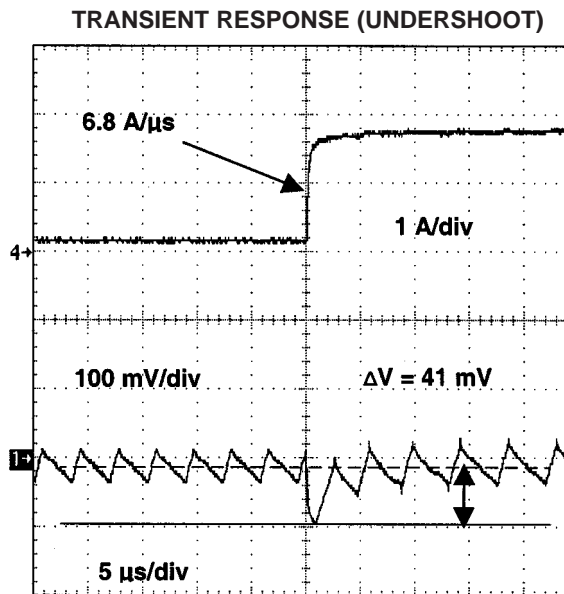

Figure 44

# TPS5103

## MULTIPLE MODE SYNCHRONOUS DC/DC CONTROLLER

SLVS240 – SEPTEMBER 1999

### APPLICATION INFORMATION

**Table 1. Bill of Materials (see Note 3)**

REF	PN	DESCRIPTION	MFG	SIZE
C1opt	10TPB220M	Capacitor, POSCAP, 220 $\mu$ F, 10 V	Sanyo	7.3x4.3mm
C1	RV-35V221MH10-R	Capacitor, electrolytic, 220 $\mu$ F, 35 V	ELNA	10x10mm
C2	GMK325F106ZH	Capacitor, ceramic, 10 $\mu$ F, 35 V	Taiyo Yuden	1210
C3	4TPB470M	Capacitor, POSCAP, 470 $\mu$ F, 4 V	Sanyo	7.3x4.3mm
C4†	std	Open, capacitor, Ceramic, 2.2 $\mu$ F, 16 V		805
C5	std	Capacitor, ceramic, 1 $\mu$ F, 16 V		805
C6	std	Capacitor, ceramic, 0.01 $\mu$ F, 16 V		805
C7	std	Capacitor, ceramic, 220 pF, 16 V		805
C8	std	Capacitor, ceramic, 100 pF, 16 V		805
C9	std	Capacitor, ceramic, 1 $\mu$ F, 16 V		805
C10	GMK316F225ZG	Capacitor, ceramic, 2.2 $\mu$ F, 35 V	Taiyo Yuden	1206
C11†	std	Open		805
C12	GMK316F225ZG	Capacitor, Ceramic, 2.2 $\mu$ F, 35 V	Taiyo Yuden	1206
C13	GMK325F106ZH	Capacitor, Ceramic, 10 $\mu$ F, 35 V	Taiyo Yuden	1210
C14		Open		
C14†opt		Open		10x10mm
C15†	std	Open, capacitor, ceramic, 1000 pF, 16 V		805
D1	MBRS340T3	Diode, Schottky, 40 V, 3 A	Motorola	SMC
D1opt	MBRS130LT3	Diode, Schottky, 30 V, 1 A	Motorola	SMB
D2	SD103-AWDICT-ND	Diode, Schottky, 40 V, 200 mA, 400 mW	Digikey	3.5x1.5mm
L1	DO3316P-682	Inductor, 6.8 $\mu$ H, 4.4 A	Coilcraft	0.5x0.37 in
J1–J14	CA26DA-D36W-0FC	Edge connector, surface-mount, 0.040" board, 0.090" standoff	NAS Interplex	0.040"
JP1	S1132-2-ND	Header, straight, 2–pin, 0.1 ctrs, 0.3" pins	Sullins	DigiKey # S1132-2-ND
JP1 Shunt	929950-00-ND	Shunt, jumper, 0.1"	3M	DigiKey #929950-00-ND
JP2	S1132-2-ND	Header, straight, 2–pin, 0.1 ctrs, 0.3" pins	Sullins	DigiKey #S1132-2-ND
R1	std	Resistor, 5.1 k $\Omega$ , 5 %		805
R2†	std	Open, resistor, 1 k $\Omega$ , 5%		805
R3	std	Resistor, 910 $\Omega$ , 1%		805
R4	std	Resistor, 1.74 k $\Omega$ , 1%		805
R5	std	Resistor, 5.1 k $\Omega$ , 5%		805
R6A	std	Resistor, 82 k $\Omega$ , 5%		805
R6B†	std	Open, 0 $\Omega$ , 5%		805
R7	std	Resistor, 1 k $\Omega$ , 5%		805
R9	std	Resistor, 1 k $\Omega$ , 5%		805
R10	std	Resistor, 1 k $\Omega$ , 5%		805
R11	std	Resistor, 10 $\Omega$ , 5%		805
R12	std	Resistor, 51 k $\Omega$ , 5%		805
R13†	std	Open		805
Q1	Si4410DY	Transistor, MOSFET, n-ch, 30-V, 10-A, 13-m $\Omega$	Siliconix	SO–8
Q2	Si4410DY	Transistor, MOSFET, n-ch, 30-V, 10-A, 13-m $\Omega$	Siliconix	SO–8
U1	TPS5103	IC, controller	TI	SSOP–20

† Components for optional mode test only.

NOTE 3: This operation mode is PWM mode only.

# TPS5103 MULTIPLE MODE SYNCHRONOUS DC/DC CONTROLLER

SLVS240 – SEPTEMBER 1999

---

## APPLICATION INFORMATION

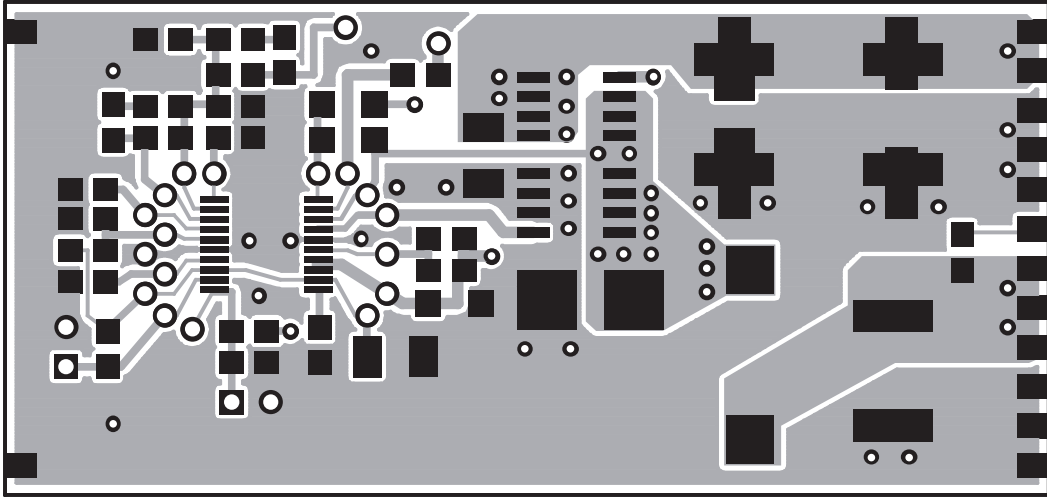

Top Layer

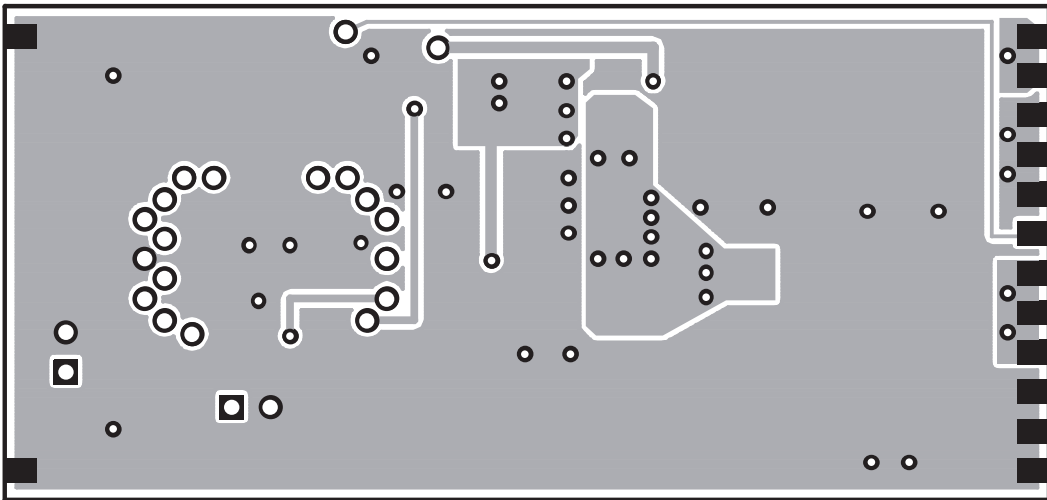

Bottom Layer (Top View)



# TPS5103 MULTIPLE MODE SYNCHRONOUS DC/DC CONTROLLER

SLVS240 – SEPTEMBER 1999

## APPLICATION INFORMATION

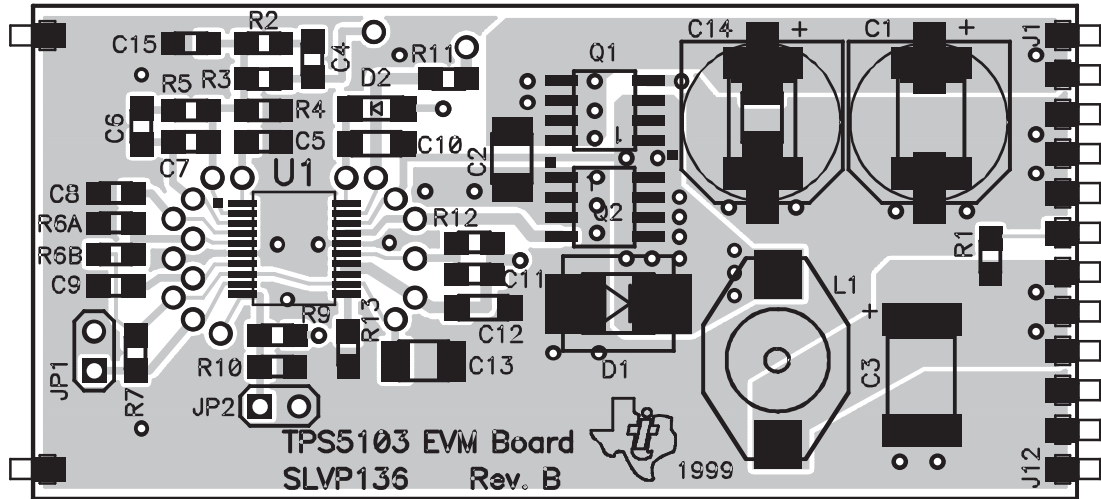

Top Assembly

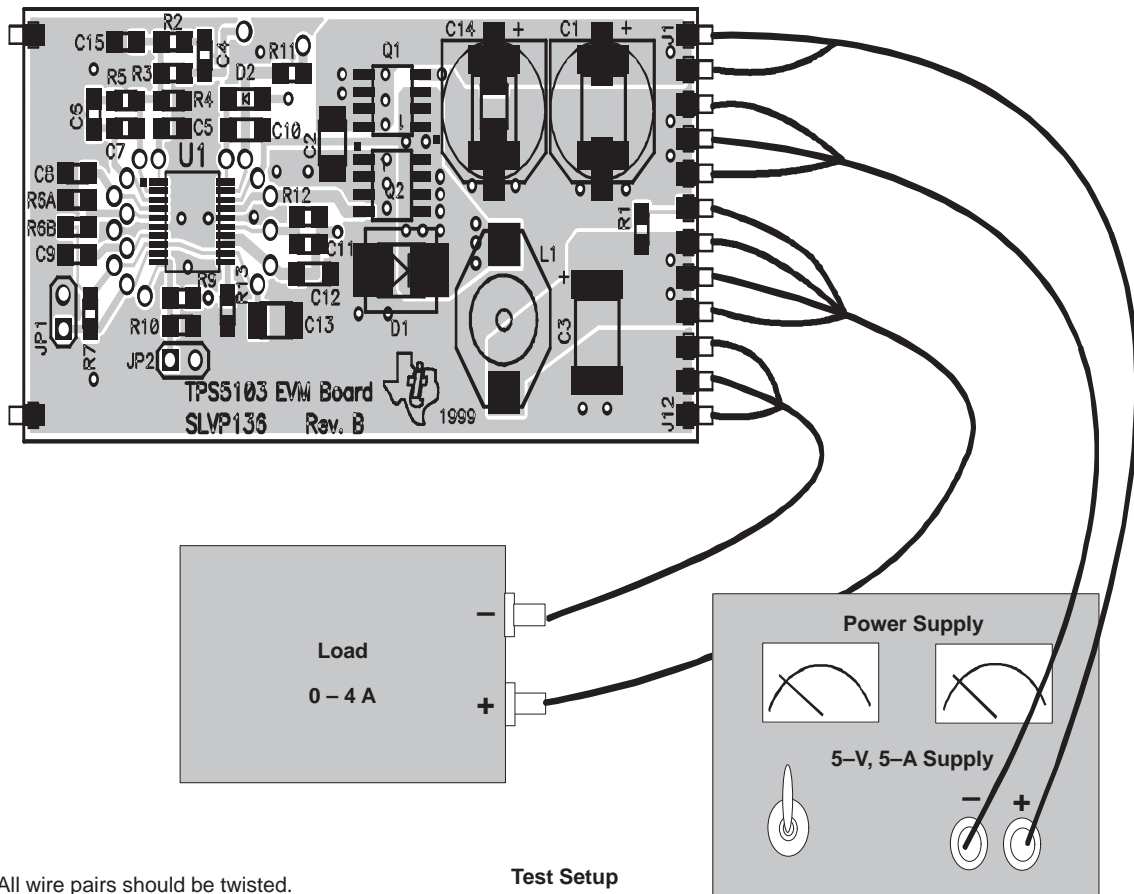

NOTE: All wire pairs should be twisted.

# TPS5103 MULTIPLE MODE SYNCHRONOUS DC/DC CONTROLLER

SLVS240 – SEPTEMBER 1999

## APPLICATION INFORMATION

**Table 2. Test Specifications**

PARAMETER	CONDITIONS	MIN	TYP	MAX	UNITS
Input voltage range		5		25	V
Output voltage range	$V_i = 5 - 25\text{ V}$ $I_o = 0 - 4\text{ A}$	1.7	1.8	1.9	V
Output current range	$V_i = 5 - 10\text{ V}$	0		4	A
Output current limit	$V_i = 5\text{ V}$	4.3			A
Output ripple	$V_i = 5\text{ V}$ , $I_o = 4\text{ A}$			50	mVp-p
Operating frequency	$I_o = 4\text{ A}$	150		250	KHz
Efficiency	$V_i = 5\text{ V}$ , $V_o = 1.8\text{ V}$ , $I_o = 4\text{ A}$		90		%

**Table 3. EVM Operating Specifications**

SKIP MODE	HYS MODE
Remove JP1 shunt	Remove R5, C6 and C7
	Remove R6A
	Add R6B
	Add C15
	If it needs the loop-compensation, add R2 and C4

This EVM is designed to cover as many applications as possible. For some more specific applications, the circuit can be simpler. The table below gives some recommendations.

**Table 4. EVM Application Recommendations**

5-V INPUT VOLTAGE	<3-A OUTPUT CURRENT	DIODE VERSION
Change C1 to low profile capacitor Sanyo 10TPB220M (220 $\mu\text{F}$ , 10 V) Or 6TPB330M (330 $\mu\text{F}$ , 6.3 V)	Change Q1 and Q2 to dual pack MOSFET, IRF7311 to reduce the cost.	Remove Q2 to reduce the cost.
Remove R10		

**Table 5. Vendor and Source Information**

MATERIAL	SOURCE	PART NUMBER	DISTRIBUTORS
MOSFETS (Q1-Q2)	In EVM design	Si4410	Local distributor
	Second source	IRF7811 (International Rectifier)	
INPUT CAPACITORS (C1)	In EVM design	RV-35V221MH10-R (ELNA)	Bell Microproducts 972-783-4191
	Second source	35CV330AX/GX (Sanyo)	870-633-5030
		UUR1V221MNR1GS (Nichicon)	Future Electronics (Local Office)
MAIN DIODES (D1)	In EVM design	MBRS340T3 (Motorola)	Local distributors
	Second source	U3FWJ44N (Toshiba)	Local distributors
INDUCTORS (L1)	In EVM design	DO3316P-682 (Coilcraft)	972-458-2645
	Second source	CTDO3316P-682 (Inductor Warehouse)	800-533-8295
CERAMIC CAPACITORS (C2, C14) (C12, C10)	IN EVM design	GMK325F106ZH GMK316F225ZG (Taiyo Yuden)	SMEC 512-331-1877
		Taiyo Yuden representative	e-mail: mike@millsales.com

# TPS5103

## MULTIPLE MODE SYNCHRONOUS DC/DC CONTROLLER

SLVS240 – SEPTEMBER 1999

### APPLICATION INFORMATION

High current applications are described in Table 6. The values are recommendations based on actual test circuits. Many variations are possible based on the requirements of the user. Performance of the circuit is dependent upon the layout rather than on the specific components, if the device parameters are not exceeded. The power stage, having the highest current levels and greatest dv/dt rates, should be given the most attention, as both the supply and load can be severely affected by the power levels and edge rates.

**Table 6. High Current Applications**

REFERENCE DESIGNATIONS	FUNCTION	8-A OUTPUT	12-A OUTPUT	16-A OUTPUT
C1	Input bulk capacitor	2x ELNA RV-35V221MH10-R 220 $\mu$ F, 35 V	3x ELNA RV-35V221MH10-R 220 $\mu$ F, 35 V	4x ELNA RV-35V221MH10-R 220 $\mu$ F, 35 V
C2	Input bypass capacitor	2x Taiyo Yuden GMK325F106ZH 10 $\mu$ F, 35 V	3x Taiyo Yuden GMK325F106ZH 10 $\mu$ F, 35 V	4x Taiyo Yuden GMK325F106ZH 10 $\mu$ F, 35 V
L1	Output filter inductor	Coiltronics UP3B-2R2 2.2 $\mu$ H, 9.2 A	Coiltronics UP4B-1R5 1.5 $\mu$ H, 13.4 A	MicorMetals T68-8/90 Core w/7T, #16 1.0 $\mu$ H, 25 A
C3	Output filter capacitor	2x Sanyo 4TPB470M 470 $\mu$ F, 4 V	3x Sanyo 4TPB470M 470 $\mu$ F, 4 V	4x Sanyo 4TPB470M 470 $\mu$ F, 4 V
Q1	Power switch	2x Siliconix Si4410DY 30 V, 10 A, 13 m $\Omega$	3x Siliconix Si4410DY 30 V, 10 A, 13 m $\Omega$	4x Siliconix Si4410DY 30 V, 10 A, 13 m $\Omega$
Q2	Power switch	2x Siliconix Si4410DY 30 V, 10 A, 13 m $\Omega$	3x Siliconix Si4410DY 30 V, 10 A, 13 m $\Omega$	4x Siliconix Si4410DY 30 V, 10 A, 13 m $\Omega$
R11	Gate drive resistor	7 $\Omega$	5 $\Omega$	4 $\Omega$
R12	Current limit resistor	10 k $\Omega$	15 k $\Omega$	20 k $\Omega$
Switching frequency		200 kHz	150 kHz	100 kHz

# TPS5103 MULTIPLE MODE SYNCHRONOUS DC/DC CONTROLLER

SLVS240 – SEPTEMBER 1999

## MECHANICAL DATA

DB (R-PDSO-G\*\*)

PLASTIC SMALL-OUTLINE PACKAGE

28 PINS SHOWN

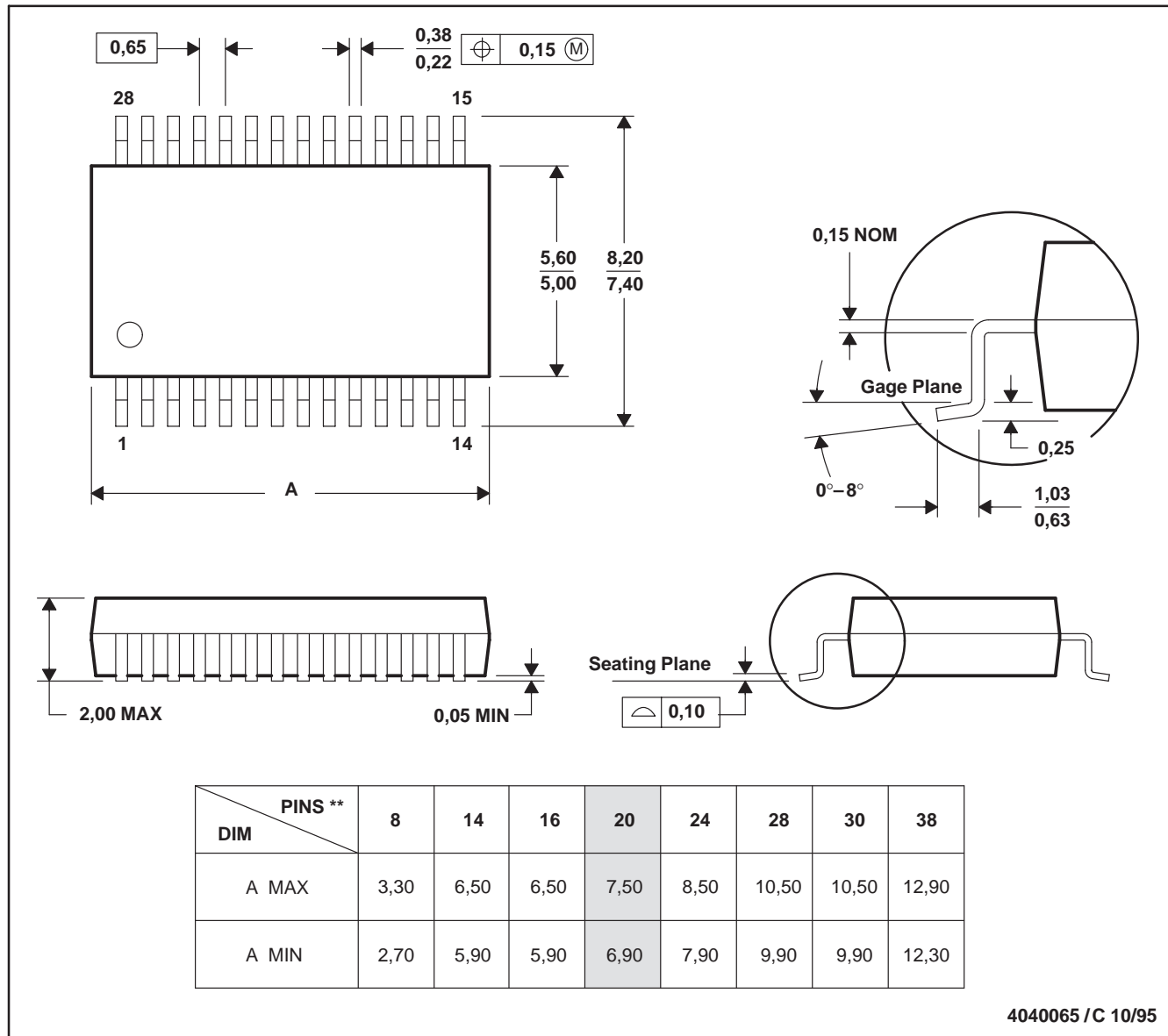

- NOTES: A. All linear dimensions are in millimeters.  
 B. This drawing is subject to change without notice.  
 C. Body dimensions do not include mold flash or protrusion not to exceed 0,15.  
 D. Falls within JEDEC MO-150

## **IMPORTANT NOTICE**

Texas Instruments and its subsidiaries (TI) reserve the right to make changes to their products or to discontinue any product or service without notice, and advise customers to obtain the latest version of relevant information to verify, before placing orders, that information being relied on is current and complete. All products are sold subject to the terms and conditions of sale supplied at the time of order acknowledgement, including those pertaining to warranty, patent infringement, and limitation of liability.

TI warrants performance of its semiconductor products to the specifications applicable at the time of sale in accordance with TI's standard warranty. Testing and other quality control techniques are utilized to the extent TI deems necessary to support this warranty. Specific testing of all parameters of each device is not necessarily performed, except those mandated by government requirements.

**CERTAIN APPLICATIONS USING SEMICONDUCTOR PRODUCTS MAY INVOLVE POTENTIAL RISKS OF DEATH, PERSONAL INJURY, OR SEVERE PROPERTY OR ENVIRONMENTAL DAMAGE ("CRITICAL APPLICATIONS"). TI SEMICONDUCTOR PRODUCTS ARE NOT DESIGNED, AUTHORIZED, OR WARRANTED TO BE SUITABLE FOR USE IN LIFE-SUPPORT DEVICES OR SYSTEMS OR OTHER CRITICAL APPLICATIONS. INCLUSION OF TI PRODUCTS IN SUCH APPLICATIONS IS UNDERSTOOD TO BE FULLY AT THE CUSTOMER'S RISK.**

In order to minimize risks associated with the customer's applications, adequate design and operating safeguards must be provided by the customer to minimize inherent or procedural hazards.

TI assumes no liability for applications assistance or customer product design. TI does not warrant or represent that any license, either express or implied, is granted under any patent right, copyright, mask work right, or other intellectual property right of TI covering or relating to any combination, machine, or process in which such semiconductor products or services might be or are used. TI's publication of information regarding any third party's products or services does not constitute TI's approval, warranty or endorsement thereof.