

VICOR CONFIDENTIAL
 THIS DOCUMENT AND THE DATA DISCLOSED
 HEREIN OR HEREWITH IS NOT TO BE REPRODUCED,
 USED, OR DISCLOSED IN WHOLE OR IN PART
 TO ANYONE WITHOUT PERMISSION OF VICOR CORP.

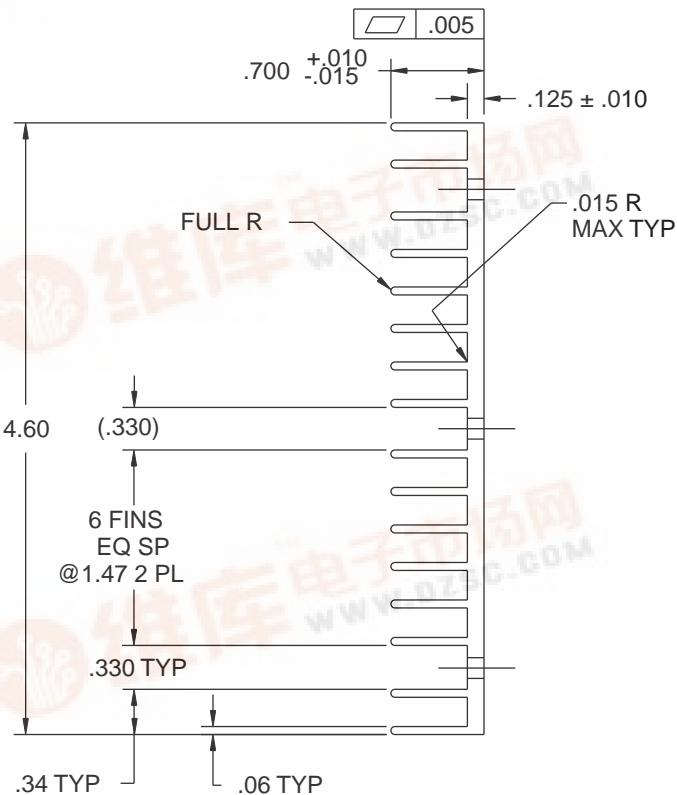
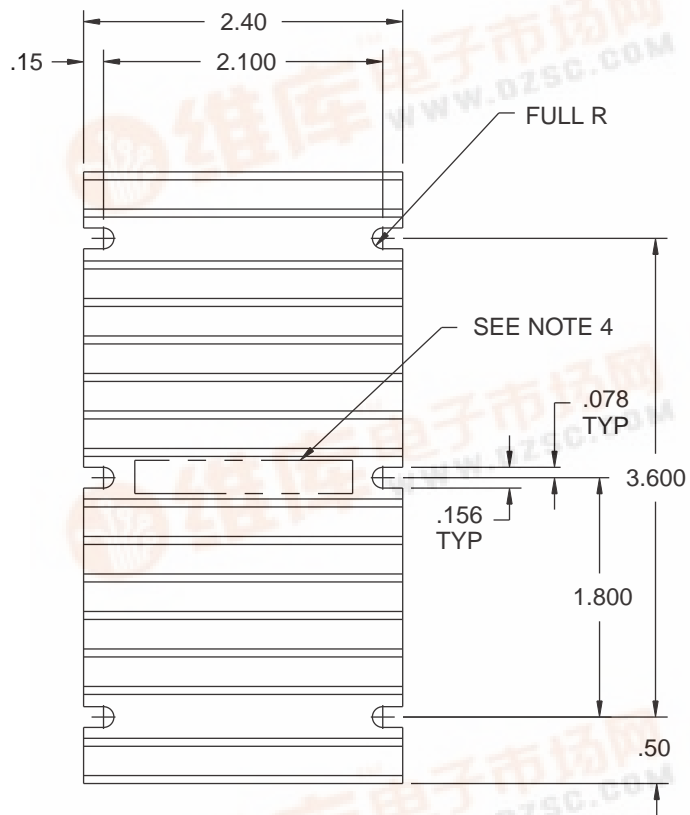

NOTES:

1. MATERIAL: 6063-T5.
2. REMOVE ALL BURRS & BREAK SHARP EDGES.
3. FINISH: CLEAR CHROMATE.
4. MECHANICALLY STAMP PART NUMBER AND REVISION # IN AREA SHOWN.

UNLESS OTHERWISE SPECIFIED
 DIMENSIONS ARE IN INCHES
 TOLERANCES ARE:

FRACTIONS DECIMALS ANGLES
 $\pm 1/64$ $\pm .XX$ $.01$ $\pm 1^\circ$
 $\pm .XXX$ $.005$

THIRD ANGLE PROJECTION

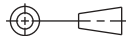

DO NOT SCALE DRAWING

APPROVALS DATE

DRAWN: 6/90



HEATSINK
 .70" HGT VERT

SIZE	FSCM NO.	DWG. NO.	REV.
B	67131	04431	04
SCALE FULL		SHEET 1 OF 1	

