

VICOR CONFIDENTIAL
 THIS DOCUMENT AND THE DATA DISCLOSED
 HEREIN OR HEREWITH IS NOT TO BE REPRODUCED,
 USED, OR DISCLOSED IN WHOLE OR IN PART
 TO ANYONE WITHOUT PERMISSION OF VICOR CORP.

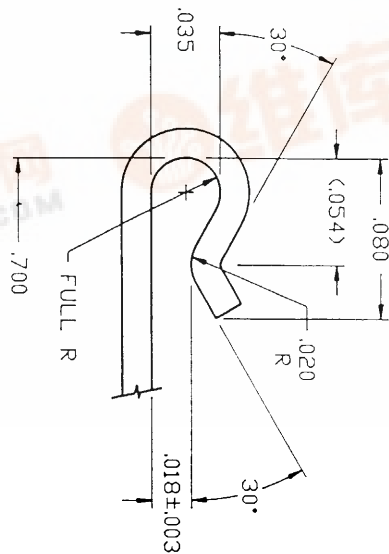
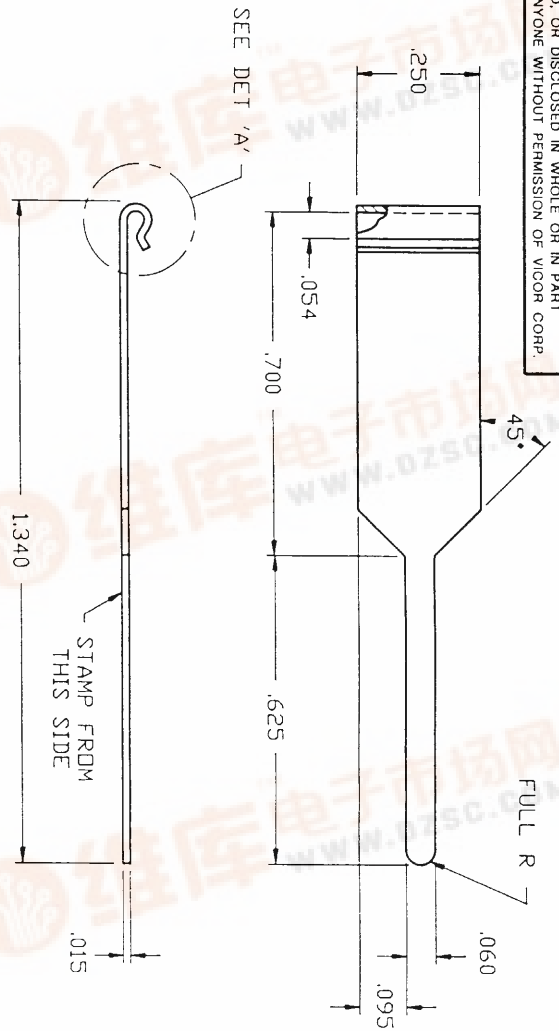

- NOTES
1. MATERIAL: 260 BRASS, .015 THK, HALF HARD.
 2. FINISH: COPPER STRIKE AND SOLDER PLATE TO 100-300 AIN THICKNESS.

UNLESS OTHERWISE SPECIFIED DIMENSIONS ARE IN INCHES TOLERANCES ARE:	
FRACTIONS	DECIMALS
$\pm 1/64$	$\pm .01$
.XXX ± .005	± .10
THIRD ANGLE PROJECTION	
DO NOT SCALE DRAWING	

APPROVALS	DATE
C HUTCHINS	4/91
CHECKED	
ISSUED	

VICOR	
GROUNDING CLIP, MODULE	
SIZE FROM NO.	DWG. NO.
B 67131	05739
SCALE 4X	SHEET 1 OF 1

REV.	DESCRIPTION	DATE	APPROVED
6	RELEASED PER ECO #E910657 CPH	11/25/91	[Signature]

