

### FEATURES

- **HIGH OUTPUT FREQUENCY:**  
f<sub>RFout</sub> = 0.8 to 2.5 GHz
- **SUPPLY VOLTAGE:**  
V<sub>CC</sub> = 2.7 to 3.3 V
- **HIGH IP<sub>3</sub> AND CONVERSION GAIN:**  
OIP<sub>3</sub> = +10 dBm typ at f<sub>RFout</sub> = 0.9 GHz  
CG = +11 dBm typ at f<sub>RFout</sub> = 0.9 GHz
- **HIGH-DENSITY SURFACE MOUNTING:**  
6-pin super minimold package

### DESCRIPTION

The UPC8187TB is a silicon monolithic integrated circuit designed as a frequency up-converter for wireless transceivers. This IC has higher operating frequency, lower distortion and higher conversion gain than the conventional UPC8163TB. This device is manufactured using NEC's 30 GHz f<sub>max</sub> UHS0 (Ultra High Speed Process) silicon bipolar process.

NEC's stringent quality assurance and test procedures ensure the highest reliability and performance.

### BLOCK DIGRAM

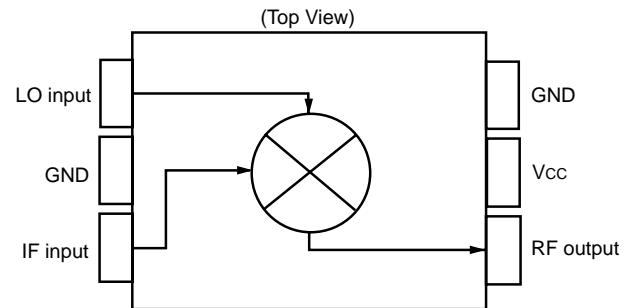

### APPLICATIONS

- TDMA, PCS, CDMA
- Digital Cellular/Cordless Phones
- Wireless Tranceivers

### ELECTRICAL CHARACTERISTICS

(T<sub>A</sub> = 25°C, V<sub>CC</sub> = V<sub>RFOUT</sub> = 2.8 V, f<sub>IFin</sub> = 150 MHz, P<sub>LOin</sub> = -5 dBm)

PART NUMBER PACKAGE OUTLINE			UPC8187TB S06			
SYMBOLS	PARAMETERS AND CONDITIONS <sup>1</sup>	UNITS	MIN	TYP	MAX	
I <sub>CC</sub>	Circuit Current (no signal)	mA	11	15	19	
CG1	Conversion Gain,	f <sub>RFout</sub> = 0.83 GHz, P <sub>IFin</sub> = -20 dBm	dB	8	14	
CG2		f <sub>RFout</sub> = 1.9 GHz, P <sub>IFin</sub> = -20 dBm	dB	8	14	
CG3		f <sub>RFout</sub> = 2.4 GHz, P <sub>IFin</sub> = -20 dBm	dB	7	10	13
P <sub>O(SAT)1</sub>	Saturated RF Output Power,	f <sub>RFout</sub> = 0.83 GHz, P <sub>IFin</sub> = 0 dBm	dBm	+1.5	+4	-
P <sub>O(SAT)2</sub>		f <sub>RFout</sub> = 1.9 GHz, P <sub>IFin</sub> = 0 dBm	dBm	0	+2.5	-
P <sub>O(SAT)3</sub>		f <sub>RFout</sub> = 2.4 GHz, P <sub>IFin</sub> = 0 dBm	dBm	-1.5	+1	-
OIP <sub>31</sub>	Output Third-Order Distortion Intercept Point,	f <sub>RFout</sub> = 0.83 GHz	dBm	-	10	-
OIP <sub>32</sub>		f <sub>RFout</sub> = 1.9 GHz				
OIP <sub>33</sub>		f <sub>RFout</sub> = 2.4 GHz				
IIP <sub>31</sub>	Input Third-Order Distortion Intercept Point,	f <sub>RFout</sub> = 0.83 GHz	dBm	-	-1.0	-
IIP <sub>32</sub>		f <sub>RFout</sub> = 1.9 GHz				
IIP <sub>33</sub>		f <sub>RFout</sub> = 2.4 GHz				
SSB•NF1	SSB Noise Figure,	f <sub>RFout</sub> = 0.83 GHz	dB	-	11	-
SSB•NF2		f <sub>RFout</sub> = 1.9 GHz				
SSB•NF3		f <sub>RFout</sub> = 2.4 GHz				

Note:

1. f<sub>RFout</sub> < f<sub>LOin</sub> @ f<sub>RFout</sub> = 0.83 GHz  
f<sub>LOin</sub> < f<sub>RFout</sub> @ f<sub>RFout</sub> = 1.9 GHz/2.4 GHz

# UPC8187TB

## ABSOLUTE MAXIMUM RATINGS<sup>1</sup>

(T<sub>A</sub> = +25°C unless otherwise specified)

SYMBOLS	PARAMETERS	UNITS	RATINGS
V <sub>CC</sub>	Supply Voltage	V	3.6
P <sub>D</sub>	Power Dissipation <sup>2</sup>	mW	270
T <sub>A</sub>	Operating Ambient Temperature	°C	-40 to +85
T <sub>STG</sub>	Storage Temperature	°C	-55 to +150
P <sub>IN</sub>	Maximum Input Power	dBm	+10

Notes:

- Operation in excess of any one of these conditions may result in permanent damage.
- Mounted on a double-sided copper clad 50x50x1.6 mm epoxy glass PWB, T<sub>A</sub> = +85°C.

## RECOMMENDED OPERATING CONDITIONS

SYMBOLS	PARAMETERS	UNITS	MIN	TYP	MAX
V <sub>CC</sub>	Supply Voltage <sup>1</sup>	V	2.7	2.8	3.3
T <sub>A</sub>	Operating Ambient Temperature	°C	-40	+25	+85
P <sub>LOin</sub>	Local Input Level <sup>2</sup>	dBm	-10	-5	0
f <sub>RFout</sub>	RF Output Frequency <sup>3</sup>	GHz	0.8	–	2.5
f <sub>IFin</sub>	IF Input Frequency	MHz	50	–	400

Notes:

- Same voltage applied to pins 5 and 6.
- Z<sub>s</sub> = 50 (without matching).
- With external matching circuit.

## SERIES PRODUCTS<sup>1</sup> (T<sub>A</sub> = +25°C, V<sub>CC</sub> = V<sub>PS</sub> = V<sub>RFout</sub> = 3.0 V, Z<sub>S</sub> = Z<sub>L</sub> = 50)

Part Number	I <sub>CC</sub> (mA)	f <sub>RFout</sub> (GHz)	CG (dB)			OIP <sub>3</sub> (dBm)			P <sub>o</sub> (SAT)		
			@RF 0.9 GHz <sup>2</sup>	@RF 1.9 GHz	@RF 2.4 GHz	@RF 0.9 GHz <sup>2</sup>	@RF 1.9 GHz	@RF 2.4 GHz	@RF 0.9 GHz <sup>2</sup>	@RF 1.9 GHz	@RF 2.4 GHz
UPC8187TB	15	0.8 to 2.5	11	11	10	+10	+10	+8.5	+4	+2.5	+1
UPC8106TB	9	0.4 to 2.0	9	7	–	+5.5	+2.0	–	-2	-4	–
UPC8172TB	9	0.8 to 2.5	9.5	8.5	8.0	+7.5	+6.0	+4.0	+0.5	0	-0.5
UPC8109TB	5	0.4 to 2.0	6	4	–	+1.5	-1.0	–	-5.5	-7.5	–
UPC8163TB	16.5	0.8 to 2.0	9	5.5	–	+9.5	+6.0	–	+0.5	-2	–

Notes:

- Typical performance.
- f<sub>RFout</sub> = 0.83 GHz @ UPC8163TB and UPC8187TB.

## PIN FUNCTIONS (Pin Voltage is measured at V<sub>CC</sub> = V<sub>PS</sub> = V<sub>RFOUT</sub> = 2.8V)

Pin No.	Pin Name	Applied Voltage (V)	Pin Voltage (V)	Function and Explanation	Equivalent Circuit
1	IFinput	–	1.2	This pin is the IF input pin to the double balanced mixer (DBM). The input is designed as a high impedance. The circuit helps suppress spurious signals. Also this symmetrical circuit can keep specified performance insensitive to process-condition distribution. For that reason, a double balanced mixer is adopted.	
2 4	GND	GND	–	GND pin. Ground pattern on the board should be formed as wide as possible. Track length should be kept as short as possible to minimize ground inductance.	
3	LOinput	–	2.1	Local input pin. Recommended input level is -10 to 0 dBm.	
5	V <sub>CC</sub>	2.7 to 3.3	–	Supply voltage pin.	
6	RFoutput	Same bias as V <sub>CC</sub> through external inductor	–	This pin is the RF output from the double balanced mixer. This pin is designed as an open collector. Due to the high impedance output, this pin should be externally equipped with an LC matching circuit to the next stage.	

**TYPICAL PERFORMANCE CURVES** (Unless otherwise specified,  $T_A = 25^\circ\text{C}$ )

$f_{RFout} = 0.83\text{ GHz}$

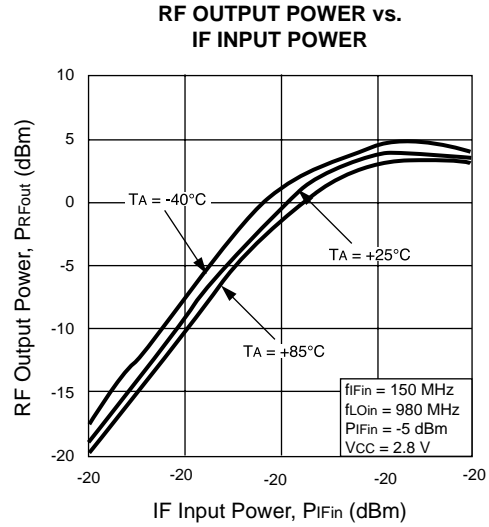
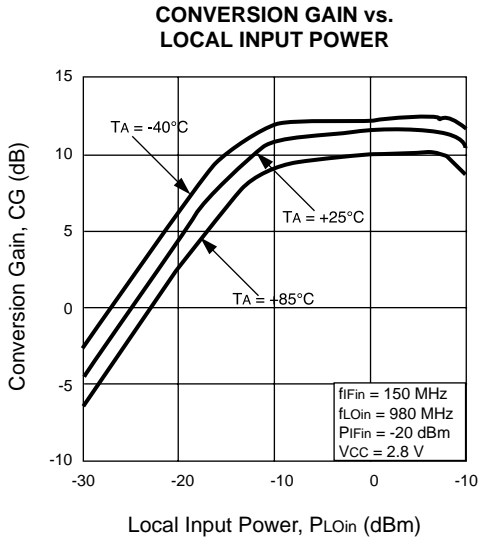

$f_{RFout} = 1.9\text{ GHz}$

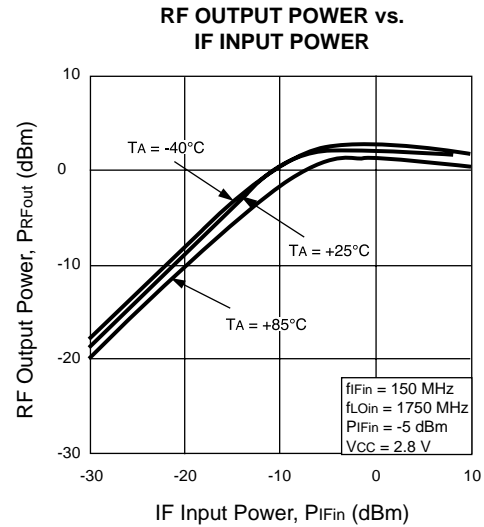
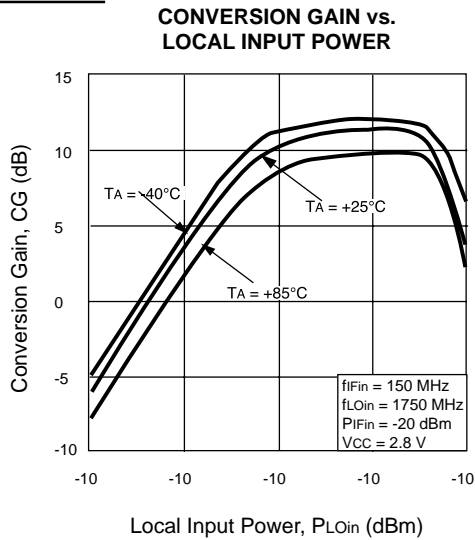

$f_{RFout} = 2.4\text{ GHz}$

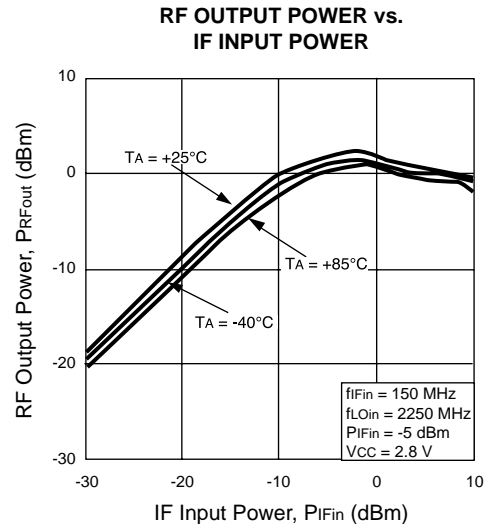
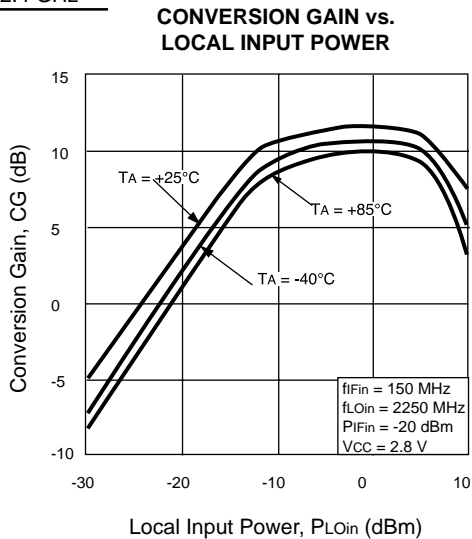

**TYPICAL SCATTERING PARAMETERS** ( $T_A = 25^\circ\text{C}$ )

LO port  
S11

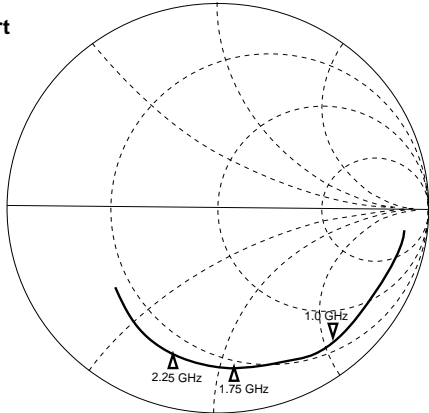

START 0.1 GHz  
STOP 3.1 GHz

RF port  
(without matching)  
S22

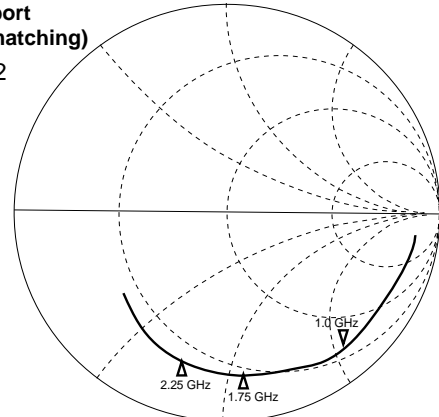

START 0.1 GHz  
STOP 3.1 GHz

$V_{CC} = V_{RFOUT} = 2.8\text{ V}$   
parameters are monitored at DUT pins

IF port  
S11

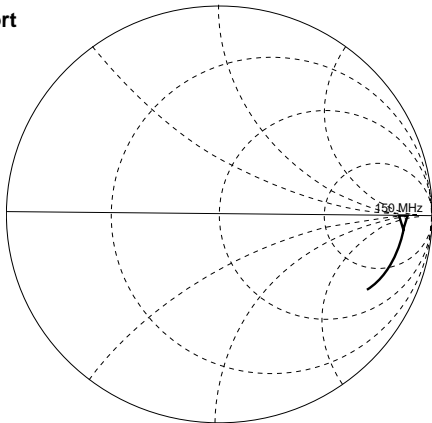

START 0.1 GHz  
STOP 1.0 GHz

**TEST CIRCUIT 1 (f<sub>R<sub>Fout</sub></sub> = 0.83 GHz)**

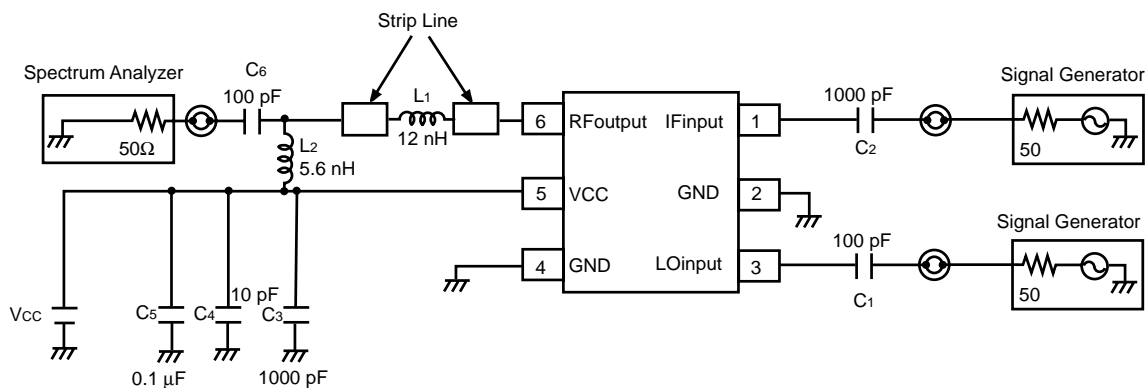

**ILLUSTRATION OF THE TEST CIRCUIT 1 ASSEMBLED ON EVALUATION BOARD**

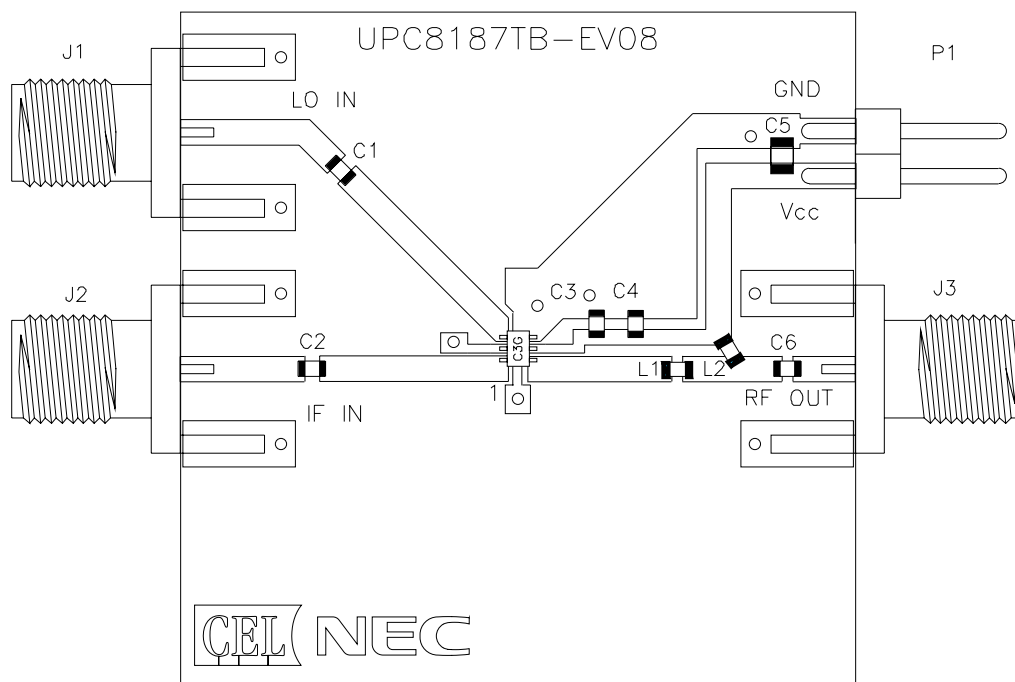

**COMPONENT LIST**

FORM	SYMBOL	VALUE
Chip Capacitor	C1, C6	100 pF
	C4	10 pF
	C2, C3	1000 pF
	C5	0.1 μF
	Chip Inductor	L1
L2		5.6 nH

1. 1.5 x 1.5 x 0.028", Getek laminate, double sided copper
2. Ground pattern on rear board
3. Solder plated patterns
4. ○ Through holes

TEST CIRCUIT 2 (f<sub>RFout</sub> = 1.9 GHz)

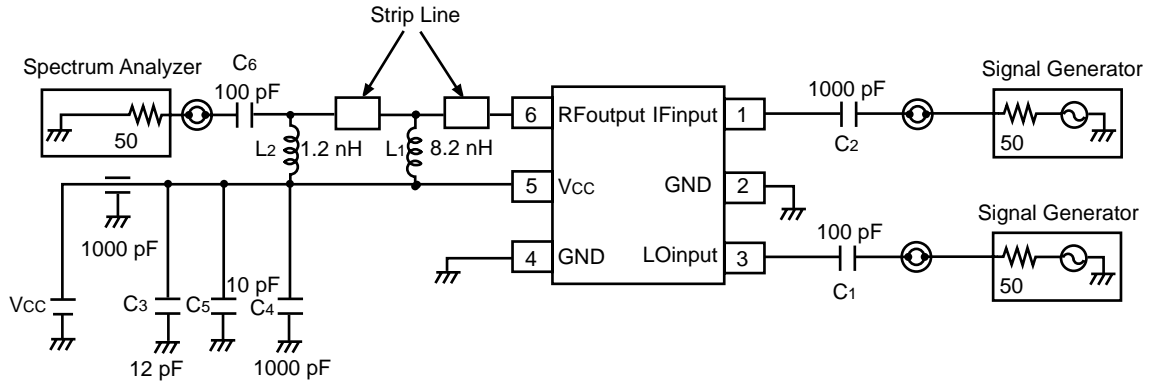
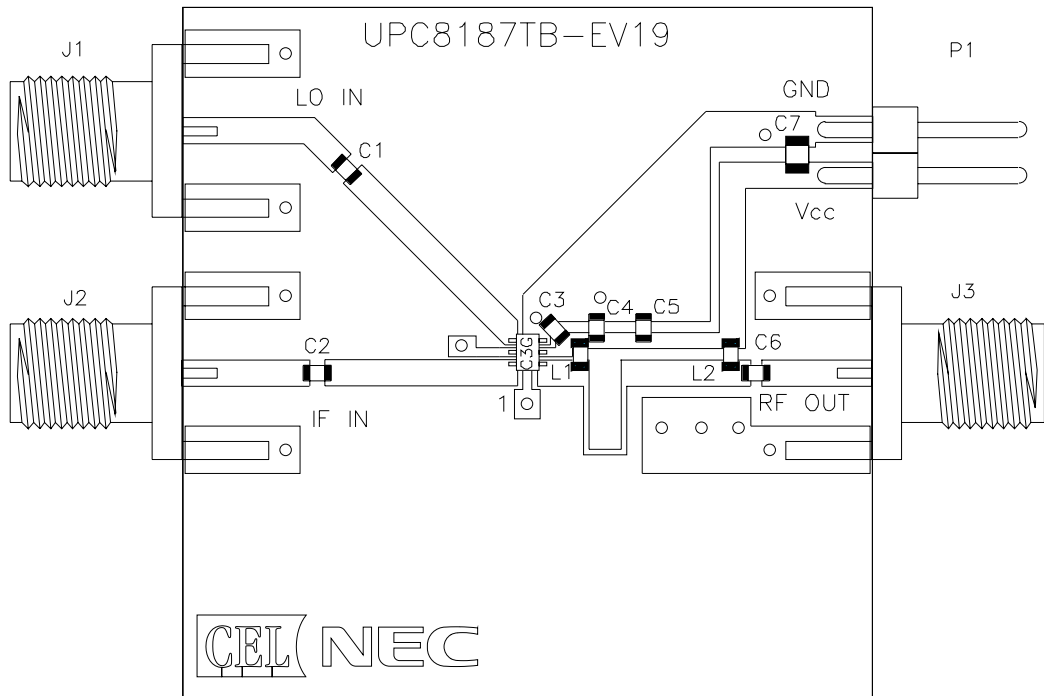

ILLUSTRATION OF TEST CIRCUIT 2 ASSEMBLED ON EVALUATION BOARD



COMPONENT LIST

FORM	SYMBOL	VALUE
Chip Capacitor	C1, C2, C4	1000 pF
	C7	0.1μF
	C6	100 pF
	C3	12 pF
	C5	10 pF
Chip Inductor	L1	8.2 nH
	L2	1.2 nH

1. 1.5 x 1.5 x 0.028", Getek laminate, double sided copper
2. Ground pattern on rear board
3. Solder plated patterns
4. ◯ Through holes



**OUTLINE DIMENSIONS** (Units in mm)

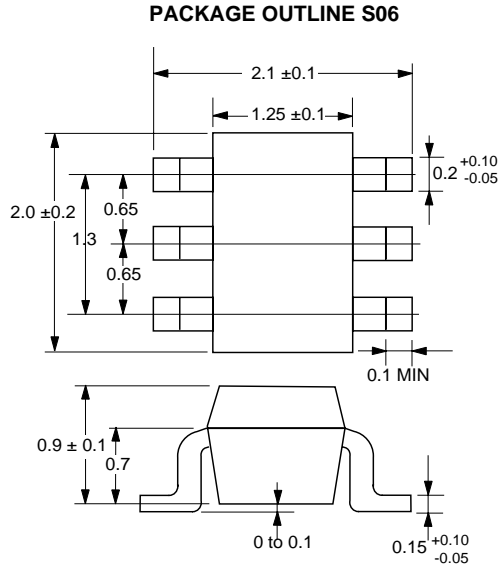

Note:  
 All dimensions are typical unless otherwise specified.

**PIN CONNECTIONS**

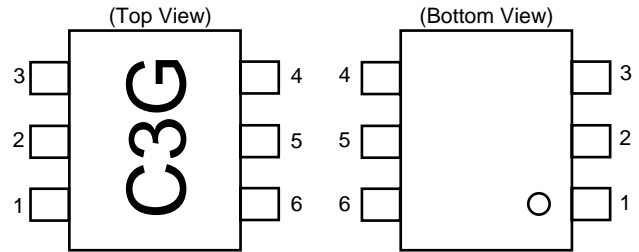

PIN NO.	PIN NAME
1	IFinput
2	GND
3	LOinput
4	GND
5	Vcc
6	RFoutput

**ORDERING INFORMATION**

Part Number	Quantity
UPC8187TB-E3	3 K pcs/reel

Note: Embossed tape, 8 mm wide. Pins 1, 2 and 3 face the tape perforation side.

**SYSTEM APPLICATION EXAMPLE** (Schematic of IC location in the system)

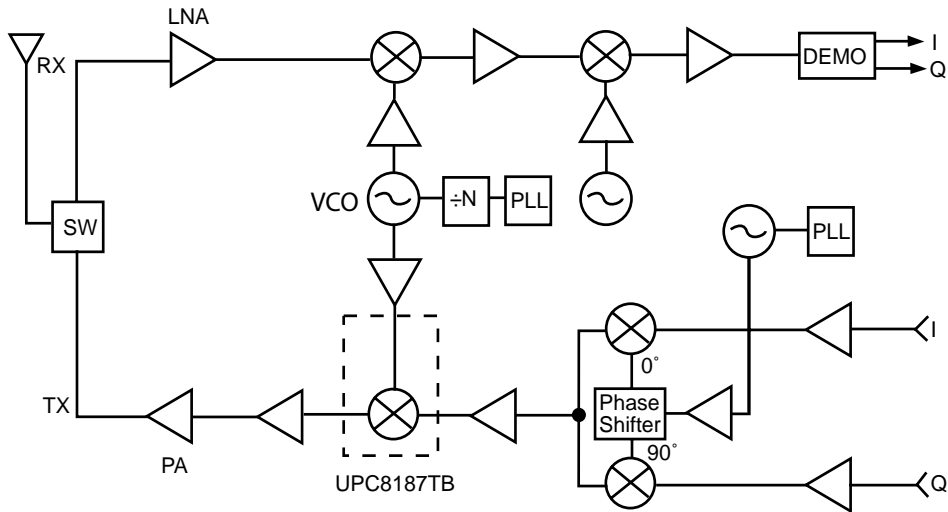

EXCLUSIVE NORTH AMERICAN AGENT FOR **NEC** RF, MICROWAVE & OPTOELECTRONIC SEMICONDUCTORS

**CEL** CALIFORNIA EASTERN LABORATORIES • Headquarters • 4590 Patrick Henry Drive • Santa Clara, CA 95054-1817 • (408) 988-3500 • Telex 34-6393 • FAX (408) 988-0279  
 24-Hour Fax-On-Demand: 800-390-3232 (U.S. and Canada only) • Internet: <http://WWW.CEL.COM>

DATA SUBJECT TO CHANGE WITHOUT NOTICE

06/14/2001



Copyright © Each Manufacturing Company.

All Datasheets cannot be modified without permission.

This datasheet has been download from :

[www.AllDataSheet.com](http://www.AllDataSheet.com)

100% Free DataSheet Search Site.

Free Download.

No Register.

Fast Search System.

[www.AllDataSheet.com](http://www.AllDataSheet.com)