

- 1N5518BUR-1 THRU 1N5546BUR-1 AVAILABLE IN JAN, JANIX AND JANIXV PER MIL-PRF-19500/437
- ZENER DIODE, 500mW
- LEADLESS PACKAGE FOR SURFACE MOUNT
- LOW REVERSE LEAKAGE CHARACTERISTICS
- METALLURGICALLY BONDED

查询1N5523BJR供应商

捷多邦 专业PCB打样工厂, 24小时加急出货

1N5518BUR-1
thru
1N5546BUR-1
and
CDLL5518 thru CDLL5546D

MAXIMUM RATINGS

Junction and Storage Temperature: -65°C to +125°C
DC Power Dissipation: 500 mW @ $T_{EC} = +125^{\circ}\text{C}$
Power Derating: 10 mW / °C above $T_{EC} = +125^{\circ}\text{C}$
Forward Voltage @ 200mA: 1.1 volts maximum

ELECTRICAL CHARACTERISTICS @ 25°C, unless otherwise specified.

CDI TYPE NUMBER (NOTE 1)	NOMINAL ZENER VOLTAGE $V_Z @ 1Z_T$ (NOTE 2)	ZENER TEST CURRENT 1Z_T	MAX. ZENER IMPEDANCE B-C-D SUFFIX $Z_{ZT} @ 1Z_T$ (NOTE 3)	MAXIMUM REVERSE LEAKAGE CURRENT			B-C-D SUFFIX MAXIMUM DC ZENER 1Z_M	REGULATION FACTOR CURRENT ΔV_Z (NOTE 5)	LOW V_Z CURRENT 1Z_L
				I_R (NOTE 4)		$V_R = \text{VOLTS}$			
				$\mu\text{A dc}$	NON & A- SUFFIX				
CDLL5518B	3.3	20	26	5.0	0.90	1.0	115	0.90	2.0
CDLL5519B	3.6	20	24	3.0	0.90	1.0	105	0.90	2.0
CDLL5520B	3.9	20	22	1.0	0.90	1.0	98	0.85	2.0
CDLL5521B	4.3	20	18	3.0	1.0	1.5	88	0.75	2.0
CDLL5522B	4.7	10	22	2.0	1.5	2.0	81	0.60	1.0
CDLL5523B	5.1	5.0	26	2.0	2.0	2.5	75	0.65	0.25
CDLL5524B	5.6	3.0	30	2.0	3.0	3.5	68	0.30	0.25
CDLL5525B	6.2	1.0	30	1.0	4.5	5.0	61	0.20	0.01
CDLL5526B	6.8	1.0	30	1.0	5.5	6.2	56	0.10	0.01
CDLL5527B	7.5	1.0	35	0.5	6.0	6.8	51	0.05	0.01
CDLL5528B	8.2	1.0	40	0.5	6.5	7.5	46	0.05	0.01
CDLL5529B	9.1	1.0	45	0.1	7.0	8.2	42	0.05	0.01
CDLL5530B	10.0	1.0	60	0.05	8.0	9.1	38	0.10	0.01
CDLL5531B	11.0	1.0	80	0.05	9.0	9.9	35	0.20	0.01
CDLL5532B	12.0	1.0	90	0.05	9.5	10.8	32	0.20	0.01
CDLL5533B	13.0	1.0	90	0.01	10.5	11.7	29	0.20	0.01
CDLL5534B	14.0	1.0	100	0.01	11.5	12.6	27	0.20	0.01
CDLL5535B	15.0	1.0	100	0.01	12.5	13.5	25	0.20	0.01
CDLL5536B	16.0	1.0	100	0.01	13.0	14.4	24	0.20	0.01
CDLL5537B	17.0	1.0	100	0.01	14.0	15.3	22	0.20	0.01
CDLL5538B	18.0	1.0	100	0.01	15.0	16.2	21	0.20	0.01
CDLL5539B	19.0	1.0	100	0.01	16.0	17.1	20	0.20	0.01
CDLL5540B	20.0	1.0	100	0.01	17.0	18.0	19	0.20	0.01
CDLL5541B	22.0	1.0	100	0.01	18.0	19.8	17	0.25	0.01
CDLL5542B	24.0	1.0	100	0.01	20.0	21.6	16	0.30	0.01
CDLL5543B	25.0	1.0	100	0.01	21.0	22.4	15	0.35	0.01
CDLL5544B	28.0	1.0	100	0.01	23.0	25.2	14	0.40	0.01
CDLL5545B	30.0	1.0	100	0.01	24.0	27.0	13	0.45	0.01
CDLL5546B	33.0	1.0	100	0.01	28.0	29.7	12	0.50	0.01

- NOTE 1** No Suffix type numbers are $\pm 20\%$ with guaranteed limits for only V_Z , I_R , and V_F . Units with "A" suffix are $\pm 10\%$ with guaranteed limits for V_Z , I_R , and V_F . Units with guaranteed limits for all six parameters are indicated by a "B" suffix for $\pm 5.0\%$ units, "C" suffix for $\pm 2.0\%$ and "D" suffix for $\pm 1.0\%$.
- NOTE 2** Zener voltage is measured with the device junction in thermal equilibrium at an ambient temperature of $25^{\circ}\text{C} \pm 3^{\circ}\text{C}$.
- NOTE 3** Zener impedance is derived by superimposing on $1Z_T$ A 60Hz rms a.c. current equal to 10% of $1Z_T$.
- NOTE 4** Reverse leakage currents are measured at V_R as shown on the table.
- NOTE 5** ΔV_Z is the maximum difference between V_Z at $1Z_T$ and V_Z at $1Z_L$ measured with the device junction in thermal equilibrium.

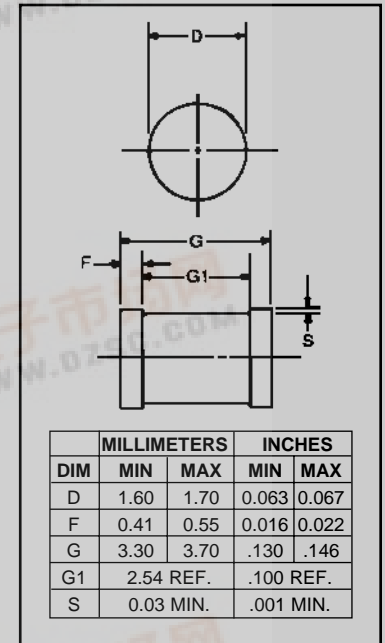

FIGURE 1

DESIGN DATA

CASE: DO-213AA, Hermetically sealed glass case. (MELF, SOD-80, LL34)

LEAD FINISH: Tin / Lead

THERMAL RESISTANCE: ($R_{\theta JC}$): 100 °C/W maximum at L = 0 inch

THERMAL IMPEDANCE: ($Z_{\theta JX}$): 35 °C/W maximum

POLARITY: Diode to be operated with the banded (cathode) end positive.

MOUNTING SURFACE SELECTION: The Axial Coefficient of Expansion (COE) Of this Device is Approximately +6PPM/°C. The COE of the Mounting Surface System Should Be Selected To Provide A Suitable Match With This Device.



CDLL5518 thru CDLL5546D

FIGURE 2

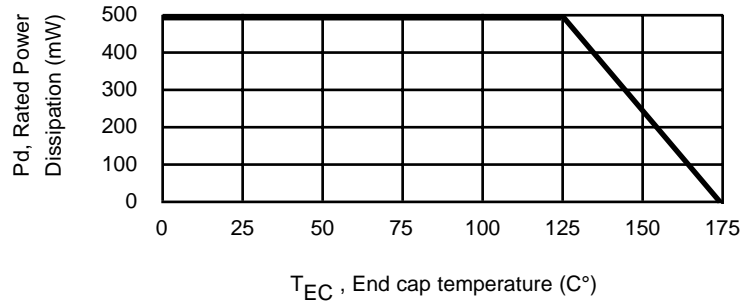

POWER DERATING CURVE

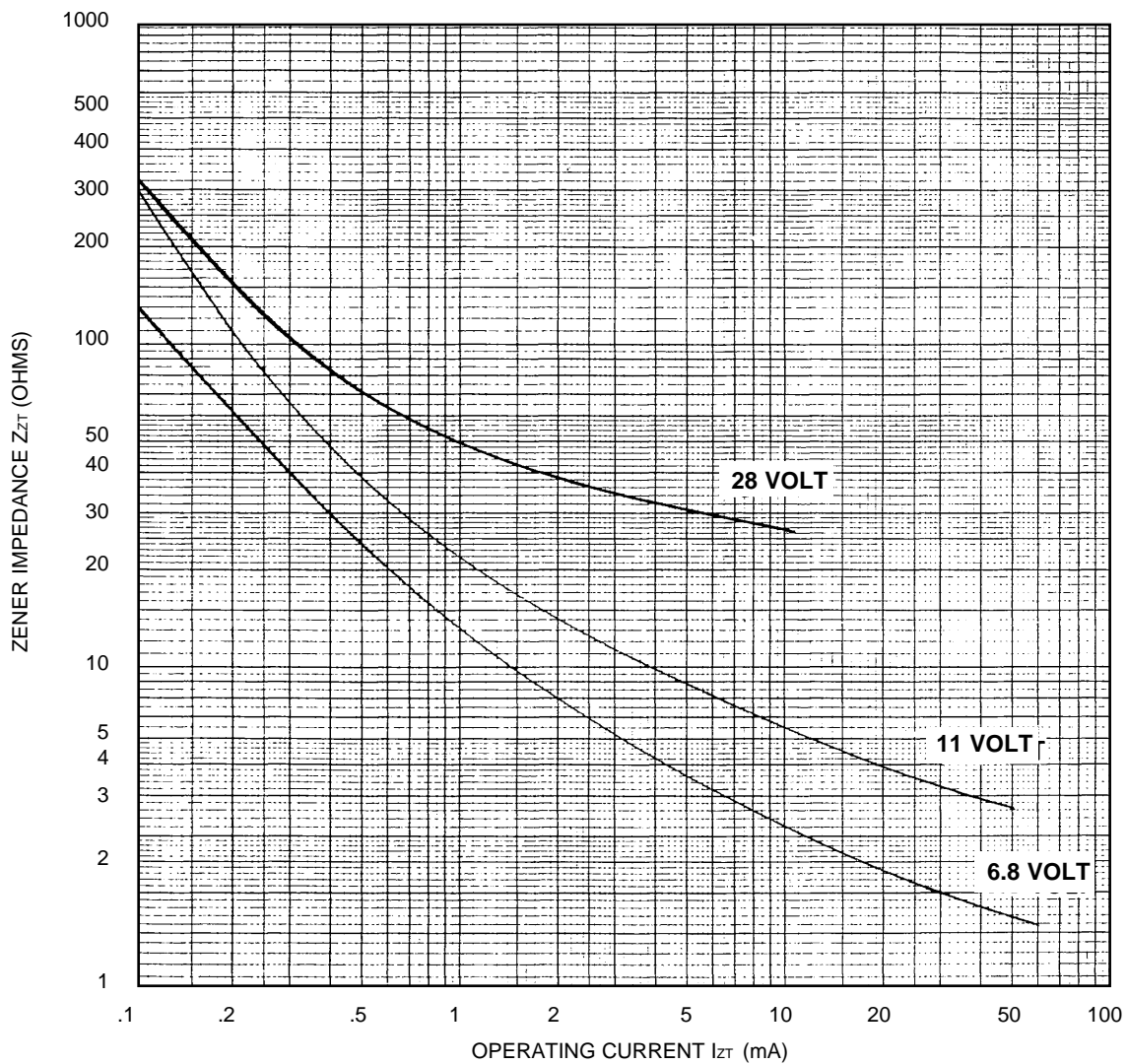

FIGURE 3

ZENER IMPEDANCE VS. OPERATING CURRENT