

High Temperature Accuracy Integrated Silicon Pressure Sensor for Measuring Absolute Pressure, On-Chip Signal Conditioned, Temperature Compensated and Calibrated

Motorola's MPXH6250A series sensor integrates on-chip, bipolar op amp circuitry and thin film resistor networks to provide a high output signal and temperature compensation. The small form factor and high reliability of on-chip integration make the Motorola pressure sensor a logical and economical choice for the system designer.

The MPXH6250A series piezoresistive transducer is a state-of-the-art, monolithic, signal conditioned, silicon pressure sensor. This sensor combines advanced micromachining techniques, thin film metallization, and bipolar semiconductor processing to provide an accurate, high level analog output signal that is proportional to applied pressure.

Figure 1 shows a block diagram of the internal circuitry integrated on a pressure sensor chip.

Features

- Improved Accuracy at High Temperature
- Available in Small and Super Small Outline Packages
- 1.5% Maximum Error over 0° to 85°C
- Ideally suited for Microprocessor or Microcontroller-Based Systems
- Temperature Compensated from -40° to +125°C
- Durable Thermoplastic (PPS) Surface Mount Package

Application Examples

- Industrial Controls
- Engine Control/Manifold Absolute Pressure (MAP)

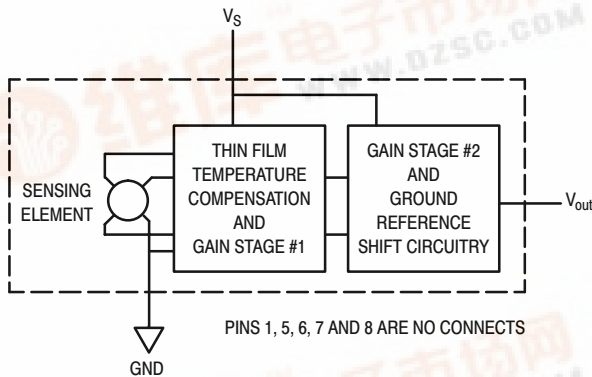
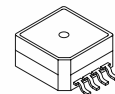

Figure 1. Fully Integrated Pressure Sensor Schematic

MPXH6250A SERIES

INTEGRATED PRESSURE SENSOR
20 to 250 kPa (3.0 to 36 psi)
0.3 to 4.9 Volts Output

SUPER SMALL OUTLINE PACKAGE



MPXH6250A6T1
CASE 1317

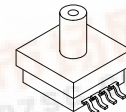

MPXH6250AC6T1
CASE 1317A

PIN NUMBER

1	N/C	5	N/C
2	V _S	6	N/C
3	Gnd	7	N/C
4	V _{out}	8	N/C

NOTE: Pins 1, 5, 6, 7, and 8 are internal device connections. Do not connect to external circuitry or ground. Pin 1 is denoted by the chamfered corner of the package.

Freescale Semiconductor, Inc.

MAXIMUM RATINGS⁽¹⁾

Parametrics	Symbol	Value	Units
Maximum Pressure (P1 > P2)	P _{max}	1000	kPa
Storage Temperature	T _{stg}	-40° to +125°	°C
Operating Temperature	T _A	-40° to +125°	°C
Output Source Current @ Full Scale Output ⁽²⁾	I _{o+}	0.5	mAdc
Output Sink Current @ Minimum Pressure Offset ⁽²⁾	I _{o-}	-0.5	mAdc

NOTES:

- Exposure beyond the specified limits may cause permanent damage or degradation to the device.
- Maximum Output Current is controlled by effective impedance from V_{out} to Gnd or V_{out} to V_S in the application circuit.

OPERATING CHARACTERISTICS (V_S = 5.1 Vdc, T_A = 25°C unless otherwise noted, P1 > P2.)

Characteristic	Symbol	Min	Typ	Max	Unit
Pressure Range	P _{OP}	20	—	250	kPa
Supply Voltage ⁽¹⁾	V _S	4.74	5.1	5.46	Vdc
Supply Current	I _o	—	6.0	10	mAdc
Minimum Pressure Offset ⁽²⁾ @ V _S = 5.1 Volts	V _{off}	0.133	0.204	0.274	Vdc
Full Scale Output ⁽³⁾ @ V _S = 5.1 Volts	V _{F_{SO}}	4.826	4.896	4.966	Vdc
Full Scale Span ⁽⁴⁾ @ V _S = 5.1 Volts	V _{F_{SS}}	4.552	4.692	4.833	Vdc
Accuracy ⁽⁵⁾	—	—	—	±1.5	%V _{F_{SS}}
Sensitivity	V/P	—	20.4	—	mV/kPa
Response Time ⁽⁶⁾	t _R	—	1.0	—	ms
Warm-Up Time ⁽⁷⁾	—	—	20	—	ms
Offset Stability ⁽⁸⁾	—	—	±0.25	—	%V _{F_{SS}}

NOTES:

- Device is ratiometric within this specified excitation range.
- Offset (V_{off}) is defined as the output voltage at the minimum rated pressure.
- Full Scale Output (V_{F_{SO}}) is defined as the output voltage at the maximum or full rated pressure.
- Full Scale Span (V_{F_{SS}}) is defined as the algebraic difference between the output voltage at full rated pressure and the output voltage at the minimum rated pressure.
- Accuracy is the deviation in actual output from nominal output over the entire pressure range and temperature range as a percent of span at 25°C due to all sources of error including the following:
 - Linearity: Output deviation from a straight line relationship with pressure over the specified pressure range.
 - Temperature Hysteresis: Output deviation at any temperature within the operating temperature range, after the temperature is cycled to and from the minimum or maximum operating temperature points, with zero differential pressure applied.
 - Pressure Hysteresis: Output deviation at any pressure within the specified range, when this pressure is cycled to and from minimum or maximum rated pressure at 25°C.
 - TcSpan: Output deviation over the temperature range of 0° to 85°C, relative to 25°C.
 - TcOffset: Output deviation with minimum pressure applied, over the temperature range of 0° to 85°C, relative to 25°C.
- Response Time is defined as the time for the incremental change in the output to go from 10% to 90% of its final value when subjected to a specified step change in pressure.
- Warm-up Time is defined as the time required for the product to meet the specified output voltage after the pressure has been stabilized.
- Offset Stability is the product's output deviation when subjected to 1000 cycles of Pulsed Pressure, Temperature Cycling with Bias Test.

Freescale Semiconductor, Inc.

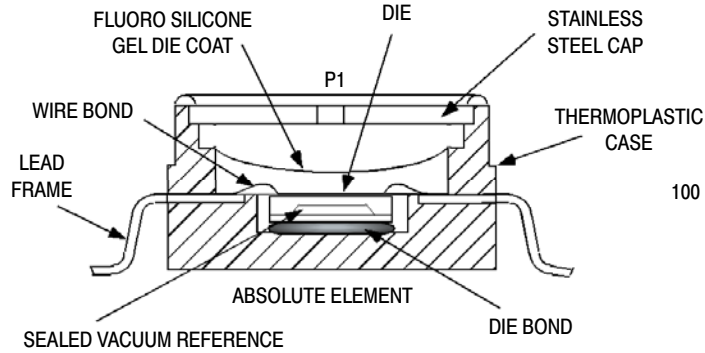

Figure 2. Cross Sectional Diagram SSOP (not to scale)

Figure 2 illustrates the absolute sensing chip in the basic Super Small Outline chip carrier (Case 1317).

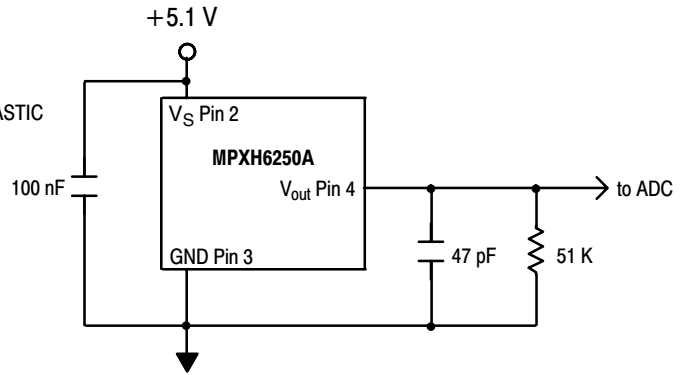

Figure 3. Typical Application Circuit (Output Source Current Operation)

Figure 3 shows a typical application circuit (output source current operation).

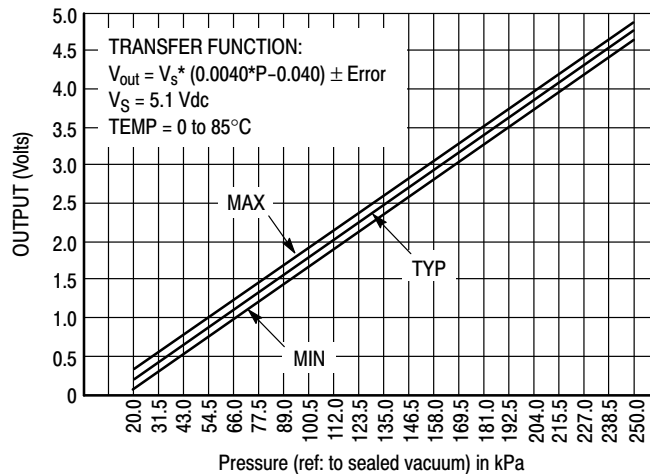

Figure 4. Output versus Absolute Pressure

Figure 4 shows the sensor output signal relative to pressure input. Typical minimum and maximum output curves are shown for operation over 0 to 85°C temperature range. The output will saturate outside of the rated pressure range.

A fluorosilicone gel isolates the die surface and wire bonds from the environment, while allowing the pressure signal to be transmitted to the silicon diaphragm. The

MPXH6250A series pressure sensor operating characteristics, internal reliability and qualification tests are based on use of dry air as the pressure media. Media other than dry air may have adverse effects on sensor performance and long-term reliability. Contact the factory for information regarding media compatibility in your application.

Freescale Semiconductor, Inc.

Transfer Function (MPXH6250A)

Nominal Transfer Value: $V_{out} = V_S \times (0.004 \times P - 0.040)$
 $\pm (\text{Pressure Error} \times \text{Temp. Factor} \times 0.004 \times V_S)$
 $V_S = 5.1 \pm 0.36 \text{ Vdc}$

Temperature Error Band

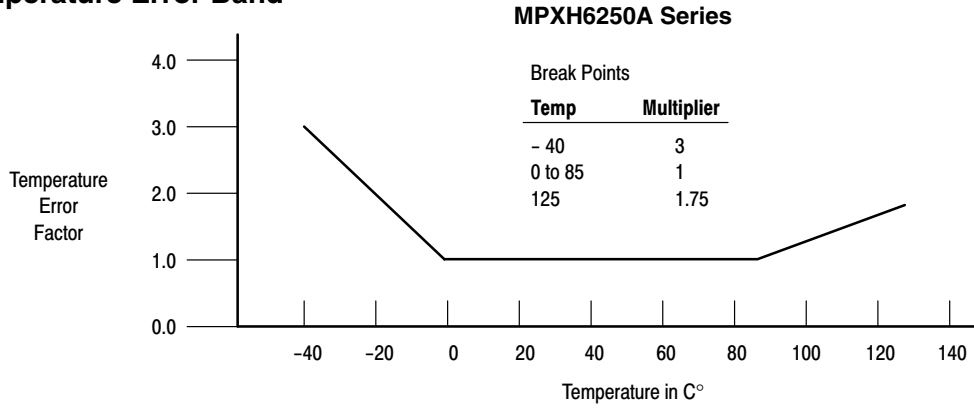

NOTE: The Temperature Multiplier is a linear response from 0°C to -40°C and from 85°C to 125°C

Pressure Error Band

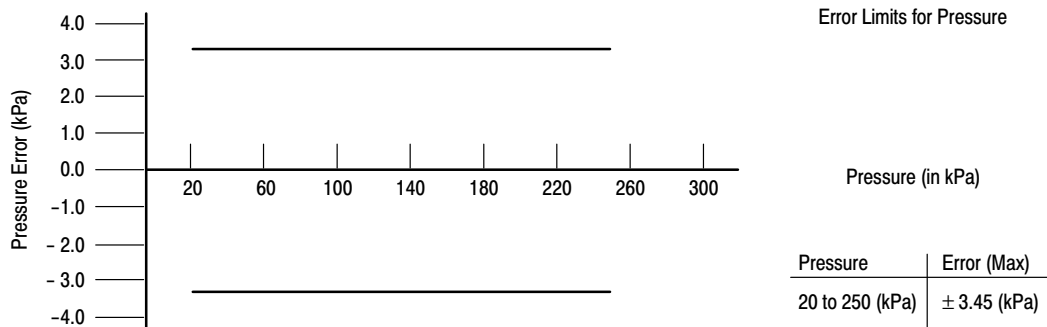

ORDERING INFORMATION — SUPER SMALL OUTLINE PACKAGE

Device Type	Options	Case No.	MPX Series Order No.	Packing Options	Marking
Basic Element	Absolute, Element Only	1317	MPXH6250A6U	Rails	MPXH6250A
	Absolute, Element Only	1317	MPXH6250A6T1	Tape and Reel	MPXH6250A
Ported Element	Absolute, Axial Port	1317A	MPXH6250AC6U	Rails	MPXH6250A
	Absolute, Axial Port	1317A	MPXH6250AC6T1	Tape and Reel	MPXH6250A

Freescale Semiconductor, Inc.

SURFACE MOUNTING INFORMATION

MINIMUM RECOMMENDED FOOTPRINT FOR SUPER SMALL OUTLINE PACKAGES

Surface mount board layout is a critical portion of the total design. The footprint for the semiconductor package must be the correct size to ensure proper solder connection interface between the board and the package. With the correct pad geometry, the packages will self-align when subjected to

a solder reflow process. It is always recommended to fabricate boards with a solder mask layer to avoid bridging and/or shorting between solder pads, especially on tight tolerances and/or tight layouts.

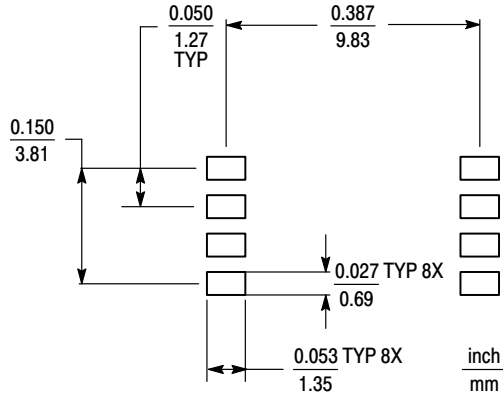
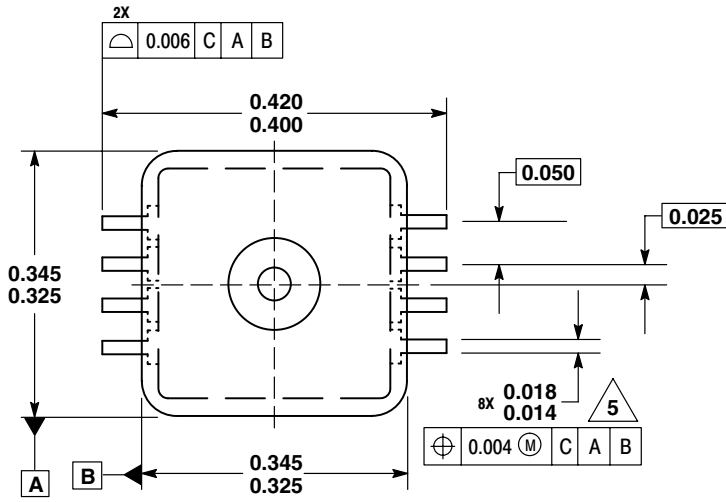

Figure 5. SSOP Footprint (Case 1317 and 1317A)

Freescale Semiconductor, Inc.

SUPER SMALL OUTLINE PACKAGE DIMENSIONS (CONTINUED)



- NOTES:
1. ALL DIMENSIONS ARE IN INCHES.
 2. DIMENSIONING AND TOLERANCING PER ASME Y14.5M-1994.
 3. DIMENSIONS DO NOT INCLUDE MOLD FLASH OR PROTRUSIONS. MOLD FLASH OR PROTRUSIONS SHALL NOT EXCEED .006 INCHES PER SIDE.
 4. ALL VERTICAL SURFACES TO BE 5° MAXIMUM.
 5. DIMENSION DOES NOT INCLUDE DAMBAR PROTRUSION. ALLOWABLE DAMBAR PROTRUSION SHALL BE .008 INCHES MAXIMUM.

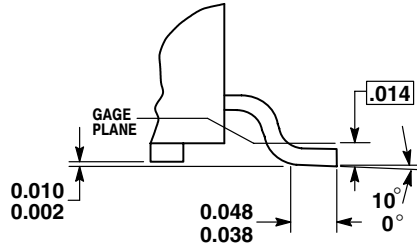

DETAIL E

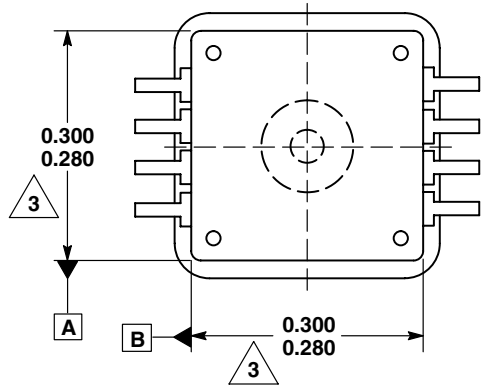
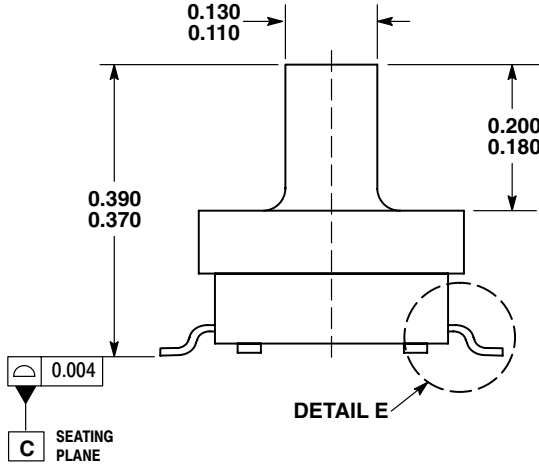

BOTTOM VIEW

CASE 1317A-01
ISSUE A

Freescale Semiconductor, Inc.

Information in this document is provided solely to enable system and software implementers to use Motorola products. There are no express or implied copyright licenses granted hereunder to design or fabricate any integrated circuits or integrated circuits based on the information in this document.

Motorola reserves the right to make changes without further notice to any products herein. Motorola makes no warranty, representation or guarantee regarding the suitability of its products for any particular purpose, nor does Motorola assume any liability arising out of the application or use of any product or circuit, and specifically disclaims any and all liability, including without limitation consequential or incidental damages. "Typical" parameters that may be provided in Motorola data sheets and/or specifications can and do vary in different applications and actual performance may vary over time. All operating parameters, including "Typicals", must be validated for each customer application by customer's technical experts. Motorola does not convey any license under its patent rights nor the rights of others. Motorola products are not designed, intended, or authorized for use as components in systems intended for surgical implant into the body, or other applications intended to support or sustain life, or for any other application in which the failure of the Motorola product could create a situation where personal injury or death may occur. Should Buyer purchase or use Motorola products for any such unintended or unauthorized application, Buyer shall indemnify and hold Motorola and its officers, employees, subsidiaries, affiliates, and distributors harmless against all claims, costs, damages, and expenses, and reasonable attorney fees arising out of, directly or indirectly, any claim of personal injury or death associated with such unintended or unauthorized use, even if such claim alleges that Motorola was negligent regarding the design or manufacture of the part.

MOTOROLA and the Stylized M Logo are registered in the US Patent and Trademark Office. All other product or service names are the property of their respective owners. Motorola, Inc. is an Equal Opportunity/Affirmative Action Employer.

© Motorola Inc. 2003

HOW TO REACH US:

USA/EUROPE/Locations Not Listed: Motorola Literature Distribution; P.O. Box 5405, Denver, Colorado 80217. 1-800-521-6274 or 480-768-2130

JAPAN: Motorola Japan Ltd.; SPS, Technical Information Center, 3-20-1, Minami-Azabu, Minato-ku, Tokyo 106-8573, Japan. 81-3-3440-3569

ASIA/PACIFIC: Motorola Semiconductors H.K. Ltd.; Silicon Harbour Centre, 2 Dai King Street, Tai Po Industrial Estate, Tai Po, N.T., Hong Kong. 852-26668334

HOME PAGE: <http://motorola.com/semiconductors>

