

DATA SHEET

74ABT16240A

74ABTH16240A

16-bit inverting buffer/driver (3-State)

Product specification
Supersedes data of 1996 Oct 01
IC23 Data Handbook

1998 Feb 25



16-bit inverting buffer/driver (3-State)

74ABT16240A 74ABTH16240A

FEATURES

- 16-bit bus interface
- 3-State buffers
- Output capability: +64mA/-32mA
- TTL input and output switching levels
- Input and output interface capability to systems at 5V supply
- Bus-hold data inputs eliminate the need for external pull-up resistors to hold unused inputs
- Live insertion/extraction permitted
- Power-up 3-State
- 74ABTH16240A incorporates bus hold data inputs which eliminate the need for external pull up resistors to hold unused inputs
- Latch-up protection exceeds 500mA per JEDEC Std 17
- ESD protection exceeds 2000V per MIL STD 883 Method 3015 and 200V per Machine Model

DESCRIPTION

The 74ABT16240A is a high-performance BiCMOS device which combines low static and dynamic power dissipation with high speed and high output drive.

This device is an inverting 16-bit buffer that is ideal for driving bus lines. The device features four Output Enables (1OE, 2OE, 3OE, 4OE), each controlling four of the 3-State outputs.

Two options are available, 74ABT16240A which does not have the bus hold feature and 74ABTH16240A which incorporates the bus hold feature.

QUICK REFERENCE DATA

SYMBOL	PARAMETER	CONDITIONS $T_{amb} = 25^{\circ}\text{C}$	TYPICAL	UNIT
t_{PLH} t_{PHL}	Propagation delay nAx to nYx	$C_L = 50\text{pF}$; $V_{CC} =$	2.0 1.8	ns
C_{IN}	Input capacitance nOE	$V_I = 0\text{V}$ or 3.0V	4	pF
C_{OUT}	Output capacitance	Outputs disabled; $V_O = 0\text{V}$ or	6	pF
I_{CCZ}	Quiescent supply current	Outputs disabled; $V_{CC} =$	500	μA
I_{CCL}		Outputs low; $V_{CC} = 5.5\text{V}$	9	mA

ORDERING INFORMATION

PACKAGES	TEMPERATURE RANGE	OUTSIDE NORTH AMERICA	NORTH AMERICA	DWG NUMBER
48-Pin Plastic SSOP Type III	-40°C to +85°C	74ABT16240A DL	BT16240A DL	SOT370-1
48-Pin Plastic TSSOP Type II	-40°C to +85°C	74ABT16240A DGG	BT16240A DGG	SOT362-1
48-Pin Plastic SSOP Type III	-40°C to +85°C	74ABTH16240A DL	BH16240A DL	SOT370-1
48-Pin Plastic TSSOP Type II	-40°C to +85°C	74ABTH16240A DGG	BH16240A DGG	SOT362-1

LOGIC SYMBOL

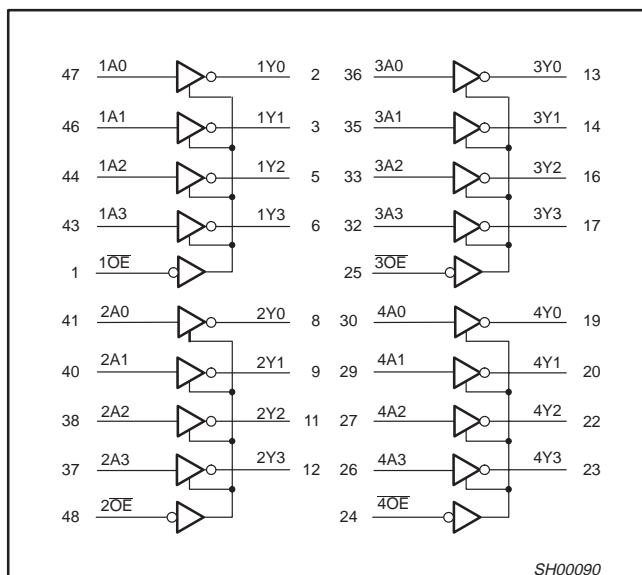

16-bit inverting buffer/driver (3-State)

74ABT16240A
74ABTH16240A

LOGIC SYMBOL (IEEE/IEC)

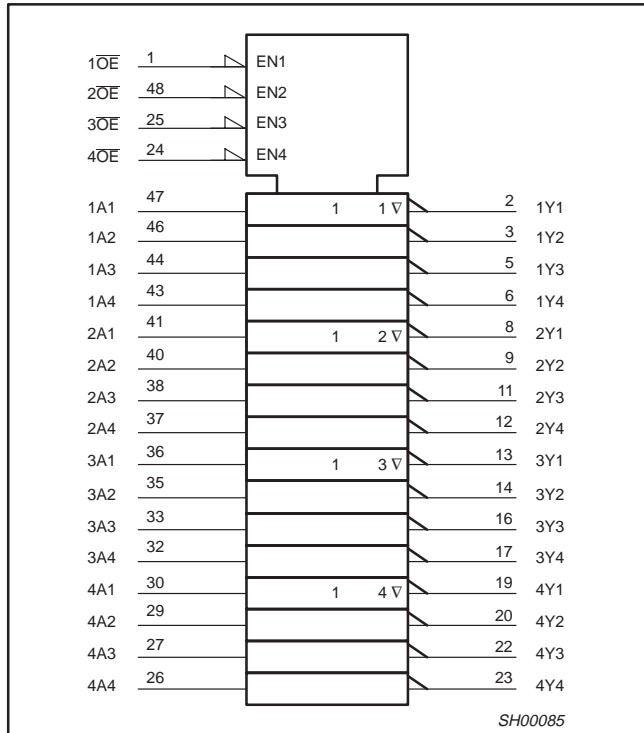

PIN DESCRIPTION

PIN NUMBER	SYMBOL	NAME AND FUNCTION
47, 46, 44, 43, 41, 40, 38, 37, 36, 35, 33, 32, 30, 29, 27, 26	1A0-1A3 2A0-2A3 3A0-3A3 4A0-4A3	Data inputs
2, 3, 5, 6, 8, 9, 11, 12, 13, 14, 16, 17, 19, 20, 22, 23	1Y0-1Y3 2Y0-2Y3 3Y0-3Y3 4Y0-4Y3	Data outputs
1, 48, 25, 24	1OE, 2OE, 3OE, 4OE	Output enables
4, 10, 15, 21, 28, 34, 39, 45	GND	Ground (0V)
7, 18, 31, 42	V _{CC}	Positive supply voltage

FUNCTION TABLE

Inputs		Outputs
nOE	nAx	nYx
L	L	H
L	H	L
H	X	Z

H = High voltage level
L = Low voltage level
X = Don't care
Z = High Impedance "off" state

PIN CONFIGURATION

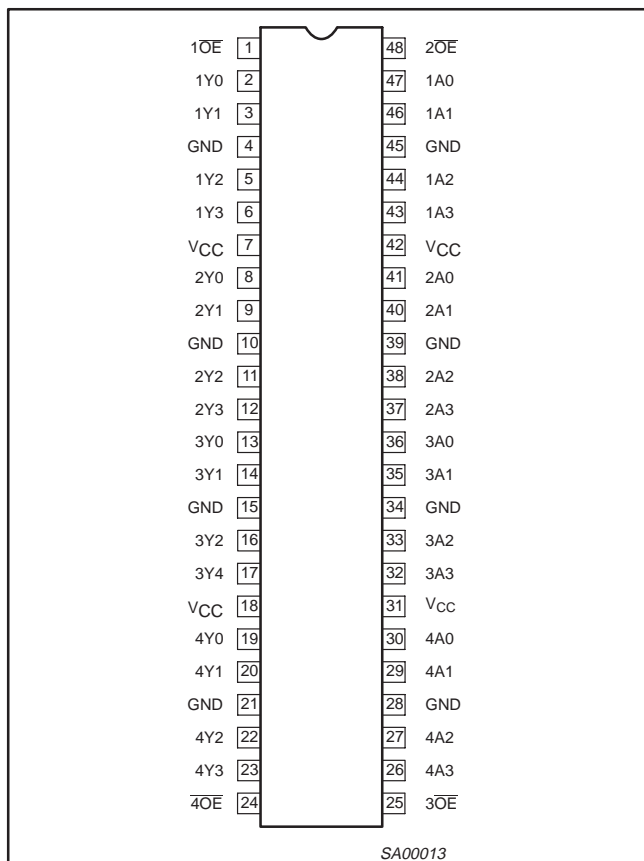

16-bit inverting buffer/driver (3-State)

74ABT16240A
74ABTH16240A**ABSOLUTE MAXIMUM RATINGS^{1, 2}**

SYMBOL	PARAMETER	CONDITIONS	RATING	UNIT
V_{CC}	DC supply voltage		-0.5 to +7.0	V
I_{IK}	DC input diode current	$V_I < 0$	-18	mA
V_I	DC input voltage ³		-1.2 to +7.0	V
I_{OK}	DC output diode current	$V_O < 0$	-50	mA
V_{OUT}	DC output voltage ³	Output in Off or High state	-0.5 to +5.5	V
I_{OUT}	DC output current	Output in Low state	128	mA
		Output in High state	-64	
T_{stg}	Storage temperature range		-65 to +150	°C

NOTES:

- Stresses beyond those listed may cause permanent damage to the device. These are stress ratings only and functional operation of the device at these or any other conditions beyond those indicated under "recommended operating conditions" is not implied. Exposure to absolute-maximum-rated conditions for extended periods may affect device reliability.
- The performance capability of a high-performance integrated circuit in conjunction with its thermal environment can create junction temperatures which are detrimental to reliability. The maximum junction temperature of this integrated circuit should not exceed 150°C.
- The input and output negative voltage ratings may be exceeded if the input and output clamp current ratings are observed.

RECOMMENDED OPERATING CONDITIONS

SYMBOL	PARAMETER	LIMITS		UNIT
		MIN	MAX	
V_{CC}	DC supply voltage	4.5	5.5	V
V_I	Input voltage	0	V_{CC}	V
V_{IH}	High-level input voltage	2.0		V
V_{IL}	Input voltage		0.8	V
I_{OH}	High-level output current		-32	mA
I_{OL}	Low-level output current		32	mA
	Low-level output current; current duty cycle $\leq 50\%$; $f \geq 1\text{kHz}$		64	
$\Delta t/\Delta v$	Input transition rise or fall rate; Outputs enabled	0	10	ns/V
T_{amb}	Operating free-air temperature range	-40	+85	°C

16-bit inverting buffer/driver (3-State)

74ABT16240A
74ABTH16240A

DC ELECTRICAL CHARACTERISTICS

SYMBOL	PARAMETER	TEST CONDITIONS	LIMITS					UNIT
			T _{amb} = +25°C			T _{amb} = -40°C to +85°C		
			Min	Typ	Max	Min	Max	
V _{IK}	Input clamp voltage	V _{CC} = 4.5V; I _{IK} = -18mA		-0.9	-1.2		-1.2	V
V _{OH}	High-level output voltage	V _{CC} = 4.5V; I _{OH} = -3mA; V _I = V _{IL} or V _{IH}	2.5	2.9		2.5		V
		V _{CC} = 5.0V; I _{OH} = -3mA; V _I = V _{IL} or V _{IH}	3.0	3.4		3.0		V
		V _{CC} = 4.5V; I _{OH} = -32mA; V _I = V _{IL} or V _{IH}	2.0	2.4		2.0		V
V _{OL}	Low-level output voltage	V _{CC} = 4.5V; I _{OL} = 64mA; V _I = V _{IL} or V _{IH}		0.42	0.55		0.55	V
I _I	Input leakage current	V _{CC} = 5.5V; V _I = GND or 5.5V		±0.01	±1.0		±1.0	µA
I _I	Input leakage current 74ABTH16240A	V _{CC} = 5.5V; V _I = V _{CC} or GND		±0.01	±1		±1	µA
		V _{CC} = 5.5V; V _I = V _{CC}		0.01	1		1	µA
		V _{CC} = 5.5V; V _I = 0		-2	-3		-5	µA
I _{HOLD}	Bus Hold current A inputs 74ABTH16240A ³	V _{CC} = 4.5V; V _I = 0.8V	50			50		µA
		V _{CC} = 4.5V; V _I = 2.0V	-75			-75		
		V _{CC} = 5.5V; V _I = 0 to 5.5V	±500					
I _{OFF}	Power-off leakage current	V _{CC} = 0.0V; V _O or V _I ≤ 4.5V		±5.0	±100		±100	µA
I _{PU} /I _{PD}	Power-up/down 3-State output current	V _{CC} = 2.0V; V _O = 0.5V; V _I = GND or V _{CC} ; V _{OE} = V _{CC}		±5.0	±50		±50	µA
I _{OZH}	3-State output High current	V _{CC} = 5.5V; V _O = 2.7V; V _I = V _{IL} or V _{IH}		1.0	10		10	µA
I _{OZL}	3-State output Low current	V _{CC} = 5.5V; V _O = 0.5V; V _I = V _{IL} or V _{IH}		-1.0	-10		-10	µA
I _{CEX}	Output high leakage current	V _{CC} = 5.5V; V _O = 5.5V; V _I = GND or V _{CC}		1.0	50		50	µA
I _O	Output current ¹	V _{CC} = 5.5V; V _O = 2.5V	-50	-70	-180	-50	-180	mA
I _{CCH}	Quiescent supply current	V _{CC} = 5.5V; Outputs High, V _I = GND or V _{CC}		0.5	1.0		1.0	mA
I _{CCL}		V _{CC} = 5.5V; Outputs Low, V _I = GND or V _{CC}		8	19		19	mA
I _{CCZ}		V _{CC} = 5.5V; Outputs 3-State; V _I = GND or V _{CC}		0.5	1.0		1.0	mA
ΔI _{CC}	Additional supply current per input pin ² 74ABT16240A	Outputs enabled, one input at 3.4V, other inputs at V _{CC} or GND; V _{CC} = 5.5V		10	200		200	µA
ΔI _{CC}	Additional supply current per input pin ² 74ABTH16240A	Outputs enabled, one input at 3.4V, other inputs at V _{CC} or GND; V _{CC} = 5.5V		0.2	1.0		1.0	mA

NOTES:

- Not more than one output should be tested at a time, and the duration of the test should not exceed one second.
- This is the increase in supply current for each input at 3.4V.
- This is the bus hold overdrive current required to force the input to the opposite logic state.

AC CHARACTERISTICS

GND = 0V; t_R = t_F = 2.5ns; C_L = 50pF; R_L = 500Ω; T_{amb} = -40°C to +85°C.

SYMBOL	PARAMETER	WAVEFORM	LIMITS					UNIT
			T _{amb} = +25°C V _{CC} = +5.0V			T _{amb} = -40°C to +85°C V _{CC} = +5.0V ±0.5V		
			Min	Typ	Max	Min	Max	
t _{PLH} t _{PHL}	Propagation delay nAx to nYx	1	1.0 1.0	2.0 1.5	3.0 3.0	1.0 1.0	3.7 3.5	ns
t _{PZH} t _{PZL}	Output enable time to High and Low level	2	1.2 1.2	2.4 2.3	3.3 3.2	1.2 1.0	4.2 4.2	ns
t _{PHZ} t _{PLZ}	Output disable time from High and Low level	2	1.3 1.3	2.7 2.5	4.1 3.6	1.6 1.4	4.7 4.1	ns

16-bit inverting buffer/driver (3-State)

74ABT16240A
74ABTH16240A

AC WAVEFORMS

$V_M = 1.5V$, $V_{IN} = GND$ to $2.7V$

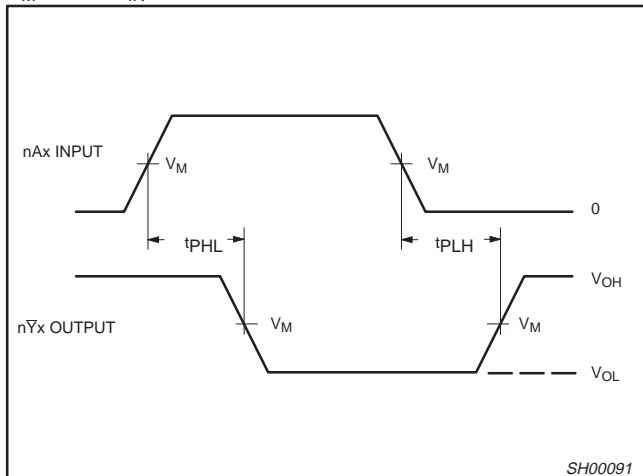

Waveform 1. Input (nAx) to Output (nYx) Propagation Delays

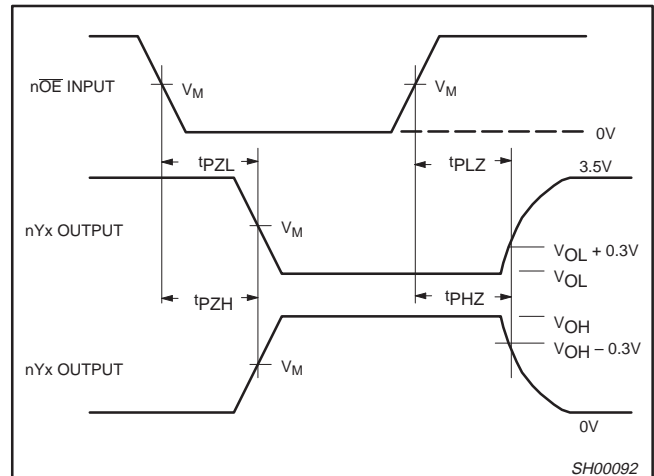

Waveform 2. 3-State Output Enable and Disable Times

TEST CIRCUIT AND WAVEFORMS

Test Circuit for 3-State Outputs

SWITCH POSITION

TEST	SWITCH
t_{PLZ}	closed
t_{PZL}	7V
All other	open

DEFINITIONS

R_L = Load resistor; see AC CHARACTERISTICS for value.
 C_L = Load capacitance includes jig and probe capacitance; see AC CHARACTERISTICS for value.
 R_T = Termination resistance should be equal to Z_{OUT} of pulse generators.

Input Pulse Definition

$V_M = 1.5V$

FAMILY	INPUT PULSE REQUIREMENTS				
	Amplitude	Rep. Rate	t_W	t_R	t_F
74ABT16	3.0V	1MHz	500ns	2.5ns	2.5ns

16-bit inverting buffer/driver (3-State)

74ABT16240A
74ABTH16240A

SSOP48: plastic shrink small outline package; 48 leads; body width 7.5 mm

SOT370-1

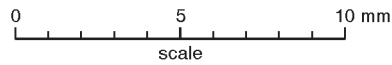
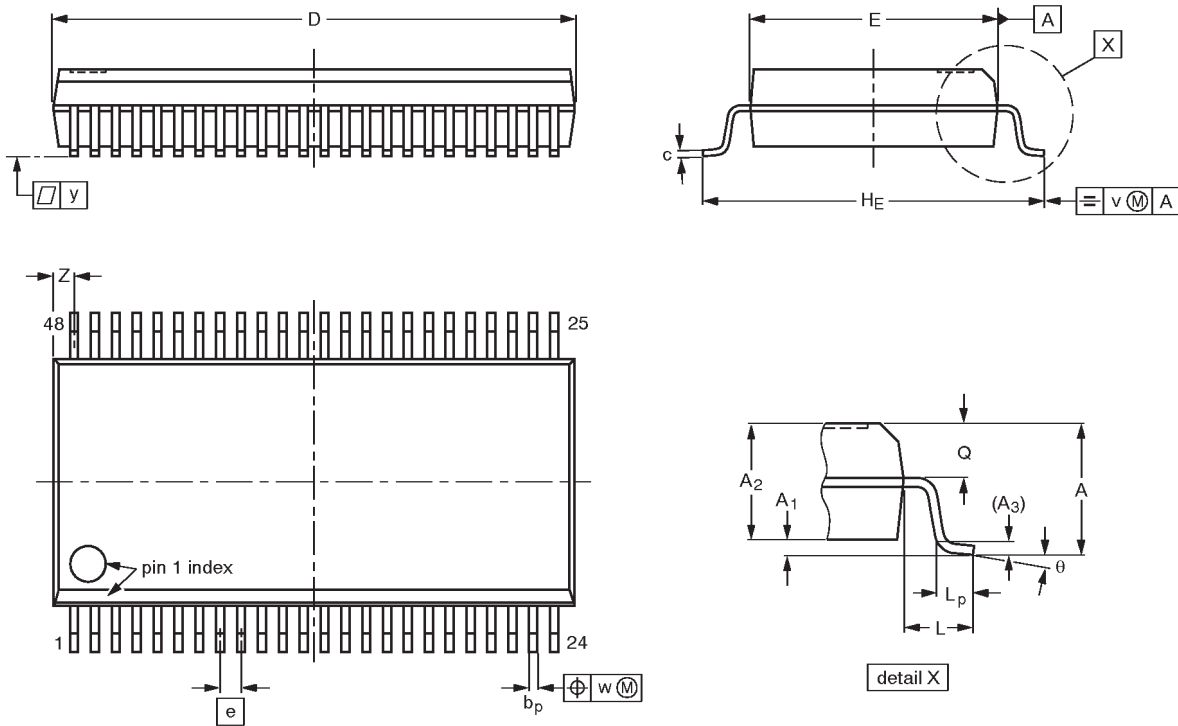

DIMENSIONS (mm are the original dimensions)

UNIT	A max.	A ₁	A ₂	A ₃	b _p	c	D ⁽¹⁾	E ⁽¹⁾	e	H _E	L	L _p	Q	v	w	y	Z ⁽¹⁾	θ
mm	2.8	0.4 0.2	2.35 2.20	0.25	0.3 0.2	0.22 0.13	16.00 15.75	7.6 7.4	0.635	10.4 10.1	1.4	1.0 0.6	1.2 1.0	0.25	0.18	0.1	0.85 0.40	8° 0°

Note

1. Plastic or metal protrusions of 0.25 mm maximum per side are not included.

OUTLINE VERSION	REFERENCES				EUROPEAN PROJECTION	ISSUE DATE
	IEC	JEDEC	EIAJ			
SOT370-1		MO-118AA				93-11-02 95-02-04

16-bit inverting buffer/driver (3-State)

74ABT16240A
74ABTH16240A

TSSOP48: plastic thin shrink small outline package; 48 leads; body width 6.1mm

SOT362-1

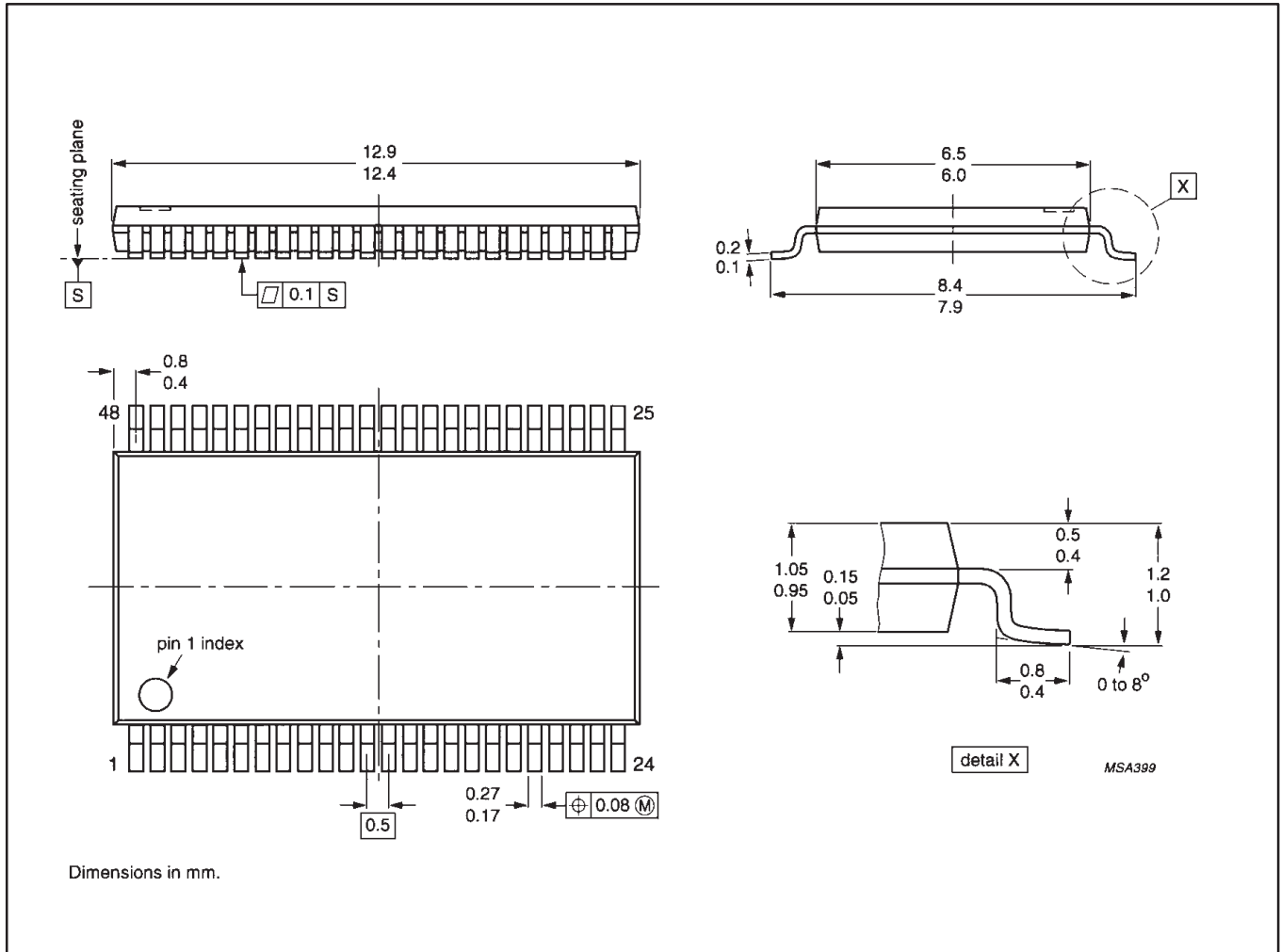

16-bit inverting buffer/driver (3-State)

74ABT16240A
74ABTH16240A

NOTES

16-bit inverting buffer/driver (3-State)

74ABT16240A
74ABTH16240A

Data sheet status

Data sheet status	Product status	Definition [1]
Objective specification	Development	This data sheet contains the design target or goal specifications for product development. Specification may change in any manner without notice.
Preliminary specification	Qualification	This data sheet contains preliminary data, and supplementary data will be published at a later date. Philips Semiconductors reserves the right to make changes at any time without notice in order to improve design and supply the best possible product.
Product specification	Production	This data sheet contains final specifications. Philips Semiconductors reserves the right to make changes at any time without notice in order to improve design and supply the best possible product.

[1] Please consult the most recently issued datasheet before initiating or completing a design.

Definitions

Short-form specification — The data in a short-form specification is extracted from a full data sheet with the same type number and title. For detailed information see the relevant data sheet or data handbook.

Limiting values definition — Limiting values given are in accordance with the Absolute Maximum Rating System (IEC 134). Stress above one or more of the limiting values may cause permanent damage to the device. These are stress ratings only and operation of the device at these or at any other conditions above those given in the Characteristics sections of the specification is not implied. Exposure to limiting values for extended periods may affect device reliability.

Application information — Applications that are described herein for any of these products are for illustrative purposes only. Philips Semiconductors make no representation or warranty that such applications will be suitable for the specified use without further testing or modification.

Disclaimers

Life support — These products are not designed for use in life support appliances, devices or systems where malfunction of these products can reasonably be expected to result in personal injury. Philips Semiconductors customers using or selling these products for use in such applications do so at their own risk and agree to fully indemnify Philips Semiconductors for any damages resulting from such application.

Right to make changes — Philips Semiconductors reserves the right to make changes, without notice, in the products, including circuits, standard cells, and/or software, described or contained herein in order to improve design and/or performance. Philips Semiconductors assumes no responsibility or liability for the use of any of these products, conveys no license or title under any patent, copyright, or mask work right to these products, and makes no representations or warranties that these products are free from patent, copyright, or mask work right infringement, unless otherwise specified.

Philips Semiconductors
811 East Arques Avenue
P.O. Box 3409
Sunnyvale, California 94088-3409
Telephone 800-234-7381

© Copyright Philips Electronics North America Corporation 1998
All rights reserved. Printed in U.S.A.

print code

Date of release: 05-96

Document order number:

9397-750-03481

Let's make things better.