

The RF MOSFET Line
RF Power Field Effect Transistors
N-Channel Enhancement-Mode Lateral MOSFETs

MRF18060A
MRF18060AR3
MRF18060ALSR3
MRF18060ASR3

Designed for PCN and PCS base station applications with frequencies from 1.8 to 2.0 GHz. Suitable for FM, TDMA, CDMA and multicarrier amplifier applications. To be used in Class AB for PCN-PCS/cellular radio and WLL applications. Specified for GSM1805 – 1880 MHz.

- Typical GSM Performance, Full Frequency Band (1805 – 1880 MHz)
 Power Gain — 13 dB (Typ) @ 60 Watts
 Efficiency — 45% (Typ) @ 60 Watts
- Internally Matched, Controlled Q, for Ease of Use
- High Gain, High Efficiency and High Linearity
- Integrated ESD Protection
- Designed for Maximum Gain and Insertion Phase Flatness
- Capable of Handling 10:1 VSWR, @ 26 Vdc, 60 Watts CW Output Power
- Excellent Thermal Stability
- Available in Tape and Reel. R3 Suffix = 250 Units per 56 mm, 13 Inch Reel.
- Available with Low Gold Plating Thickness on Leads. L Suffix Indicates 40μ" Nominal.

1.80 – 1.88 GHz, 60 W, 26 V
LATERAL N-CHANNEL
RF POWER MOSFETs

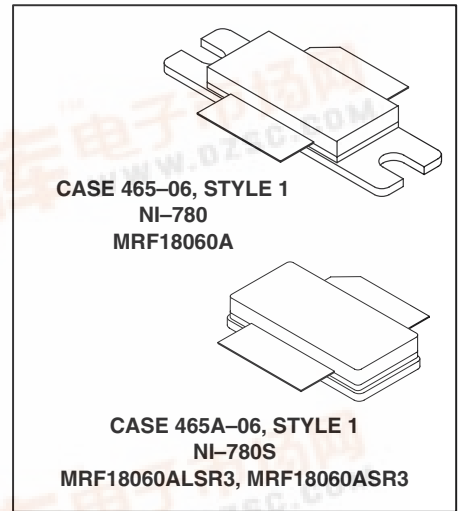

MAXIMUM RATINGS

Rating	Symbol	Value	Unit
Drain-Source Voltage	V _{DSS}	65	Vdc
Gate-Source Voltage	V _{GS}	-0.5, +15	Vdc
Total Device Dissipation @ T _C ≥ 25°C Derate above 25°C	P _D	180 1.03	Watts W/°C
Storage Temperature Range	T _{stg}	-65 to +150	°C
Operating Junction Temperature	T _J	200	°C

ESD PROTECTION CHARACTERISTICS

Test Conditions	Class
Human Body Model	2 (Minimum)
Machine Model	M3 (Minimum)

THERMAL CHARACTERISTICS

Characteristic	Symbol	Max	Unit
Thermal Resistance, Junction to Case	R _{θJC}	0.97	°C/W

NOTE – **CAUTION** – MOS devices are susceptible to damage from electrostatic charge. Reasonable precautions in handling and packaging MOS devices should be observed.



ELECTRICAL CHARACTERISTICS ($T_C = 25^\circ\text{C}$ unless otherwise noted)

Characteristic	Symbol	Min	Typ	Max	Unit
----------------	--------	-----	-----	-----	------

OFF CHARACTERISTICS

Drain–Source Breakdown Voltage ($V_{GS} = 0\text{ Vdc}$, $I_D = 10\ \mu\text{Adc}$)	$V_{(BR)DSS}$	65	—	—	Vdc
Zero Gate Voltage Drain Current ($V_{DS} = 26\text{ Vdc}$, $V_{GS} = 0\text{ Vdc}$)	I_{DSS}	—	—	6	μAdc
Gate–Source Leakage Current ($V_{GS} = 5\text{ Vdc}$, $V_{DS} = 0\text{ Vdc}$)	I_{GSS}	—	—	1	μAdc

ON CHARACTERISTICS

Gate Threshold Voltage ($V_{DS} = 10\text{ Vdc}$, $I_D = 300\ \mu\text{Adc}$)	$V_{GS(th)}$	2	—	4	Vdc
Gate Quiescent Voltage ($V_{DS} = 26\text{ Vdc}$, $I_D = 500\text{ mAdc}$)	$V_{GS(Q)}$	2.5	3.9	4.5	Vdc
Drain–Source On–Voltage ($V_{GS} = 10\text{ Vdc}$, $I_D = 2\text{ Adc}$)	$V_{DS(on)}$	—	0.27	—	Vdc
Forward Transconductance ($V_{DS} = 10\text{ Vdc}$, $I_D = 2\text{ Adc}$)	g_{fs}	—	4.7	—	S

DYNAMIC CHARACTERISTICS

Input Capacitance (Including Input Matching Capacitor in Package) (1) ($V_{DS} = 26\text{ Vdc} \pm 30\text{ mV(rms)ac}$ @ 1 MHz, $V_{GS} = 0\text{ Vdc}$)	C_{iss}	—	160	—	pF
Output Capacitance (1) ($V_{DS} = 26\text{ Vdc} \pm 30\text{ mV(rms)ac}$ @ 1 MHz, $V_{GS} = 0\text{ Vdc}$)	C_{oss}	—	740	—	pF
Reverse Transfer Capacitance ($V_{DS} = 26\text{ Vdc} \pm 30\text{ mV(rms)ac}$ @ 1 MHz, $V_{GS} = 0\text{ Vdc}$)	C_{rss}	—	2.7	—	pF

FUNCTIONAL TESTS (In Motorola Test Fixture, 50 ohm system)

Common–Source Amplifier Power Gain @ 60 W (2) ($V_{DD} = 26\text{ Vdc}$, $I_{DQ} = 500\text{ mA}$, $f = 1805 - 1880\text{ MHz}$)	G_{ps}	11.5	13	—	dB
Drain Efficiency @ 60 W (2) ($V_{DD} = 26\text{ Vdc}$, $I_{DQ} = 500\text{ mA}$, $f = 1805 - 1880\text{ MHz}$)	η	43	45	—	%
Input Return Loss (2) ($V_{DD} = 26\text{ Vdc}$, $P_{out} = 60\text{ W CW}$, $I_{DQ} = 500\text{ mA}$, $f = 1805 - 1880\text{ MHz}$)	IRL	—	—	-10	dB
Output Mismatch Stress ($V_{DD} = 26\text{ Vdc}$, $P_{out} = 60\text{ W CW}$, $I_{DQ} = 500\text{ mA}$ VSWR = 10:1, All Phase Angles at Frequency of Tests)	Ψ	No Degradation In Output Power Before and After Test			

(1) Part is internally matched both on input and output.

(2) To meet application requirements, Motorola test fixtures have been designed to cover the full GSM1800 band, ensuring batch–to–batch consistency.

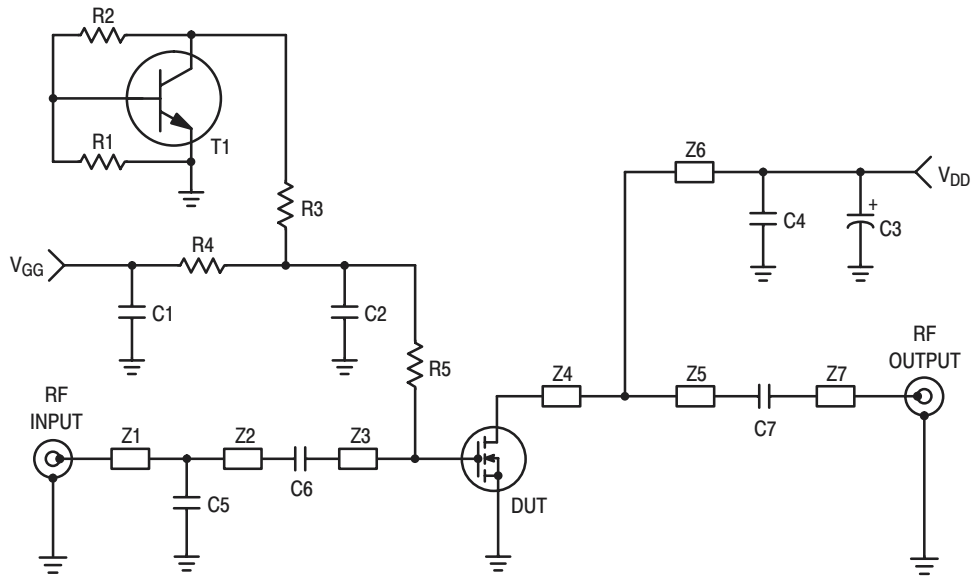

C1	100 nF Chip Capacitor (1203)	Z1	0.47" x 0.09" Microstrip
C2, C4, C7	10 pF Chip Capacitors	Z2	1.16" x 0.09" Microstrip
C3	10 μ F, 35 V Electrolytic Tantalum Capacitor	Z3	0.57" x 0.95" Microstrip
C5	1.2 pF Chip Capacitor	Z4	0.59" x 1.18" Microstrip
C6	1.0 pF Chip Capacitor	Z5	1.26" x 0.15" Microstrip
R1, R3	2.2 k Ω Chip Resistors (0805)	Z6	1.15" x 0.09" Microstrip
R2, R4	2.7 k Ω Chip Resistors (0805)	Z7	0.37" x 0.09" Microstrip
R5	1.1 k Ω Chip Resistor (0805)		
T1	BC847 Transistor SOT-23		

Figure 1. 1805 – 1880 MHz Test Fixture Schematic

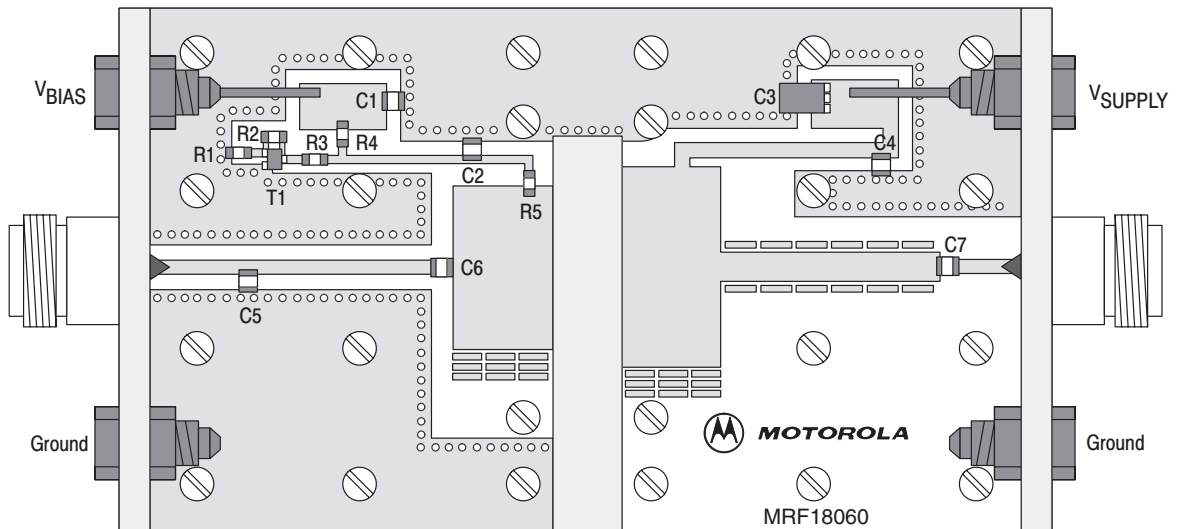
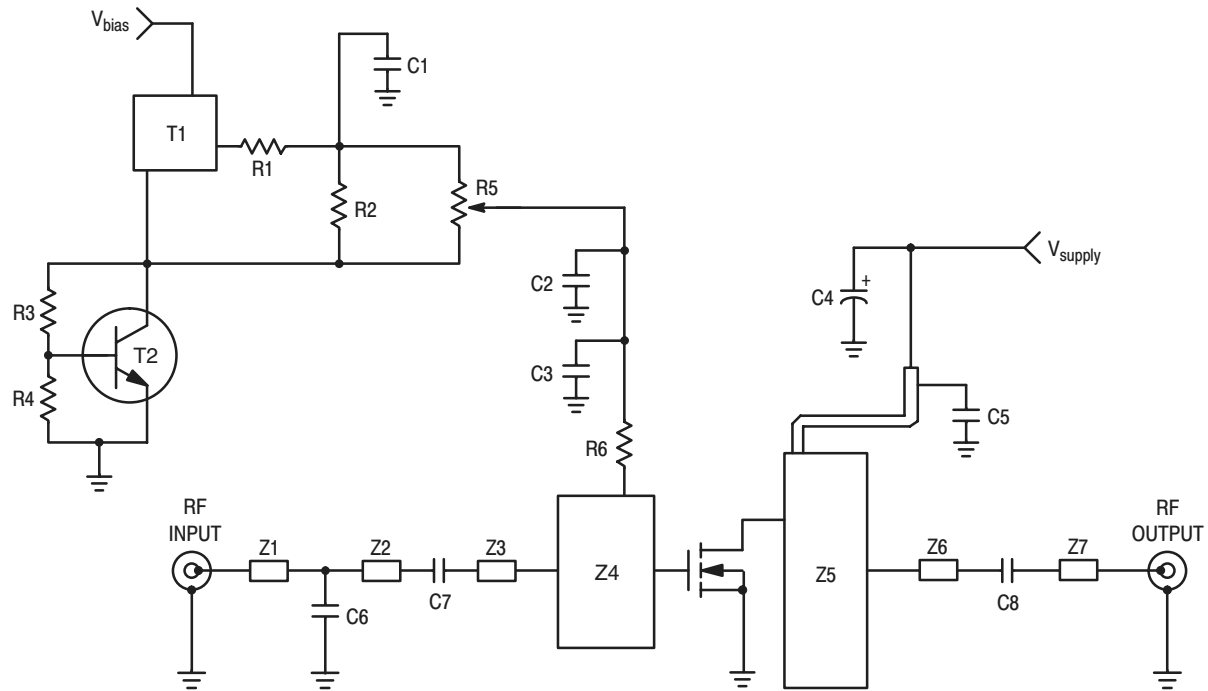

Figure 2. 1805 – 1880 MHz Test Fixture Component Layout



C1	1 μ F Chip Capacitor (0805)	T1	LP2951 Micro-8 Voltage Regulator
C2	100 nF Chip Capacitor (0805)	T2	BC847 SOT-23 NPN Transistor
C3, C5, C8	10 pF Chip Capacitors, ACCU-P (0805)	Z1	0.159" x 0.055" Microstrip
C4	10 μ F, 35 V Tantalum Electrolytic Capacitor	Z2	0.982" x 0.055" Microstrip
C6	1.8 pF Chip Capacitor, ACCU-P (0805)	Z3	0.087" x 0.055" Microstrip
C7	1 pF Chip Capacitor, ACCU-P (0805)	Z4	0.512" x 0.787" Microstrip
R1	10 Ω Chip Resistor (0805)	Z5	0.433" x 1.220" Microstrip
R2, R6	1 k Ω Chip Resistors (0805)	Z6	1.039" x 0.118" Microstrip
R3	1.2 k Ω Chip Resistor (0805)	Z7	0.268" x 0.055" Microstrip
R4	2.2 k Ω Chip Resistor (0805)		
R5	5 k Ω , SMD Potentiometer		

Substrate = 0.5 mm Teflon[®] Glass, $\epsilon_r = 2.55$

Figure 3. 1800 – 2000 MHz Demo Board Schematic

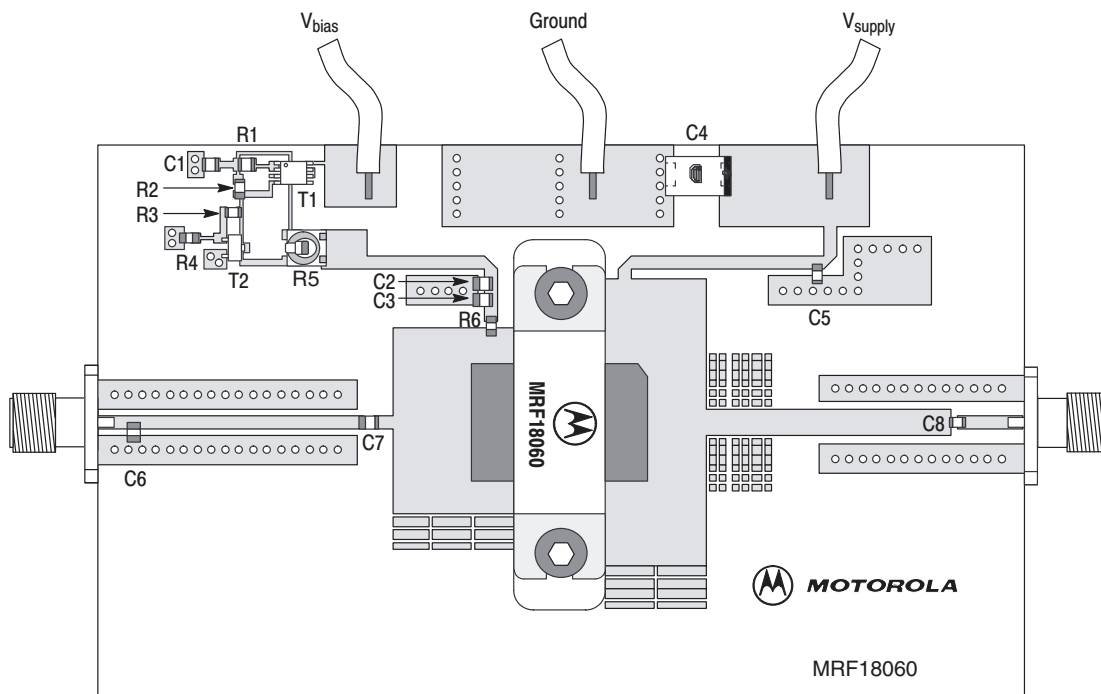

Figure 4. 1800 – 2000 MHz Demo Board Component Layout

TYPICAL CHARACTERISTICS (DATA TAKEN USING WIDEBAND DEMONSTRATION BOARD)

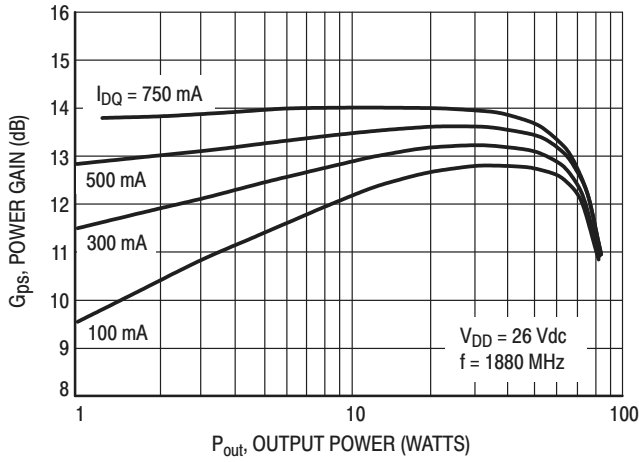

Figure 5. Power Gain versus Output Power

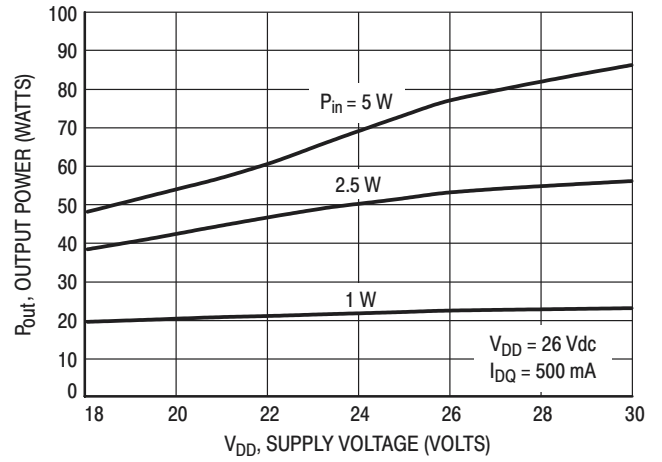

Figure 6. Output Power versus Supply Voltage

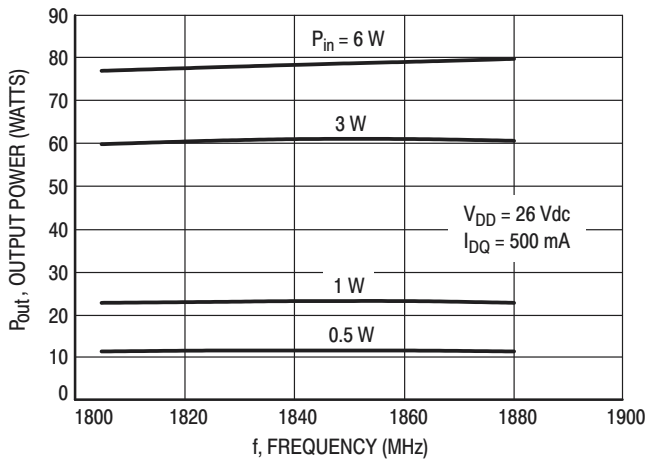

Figure 7. Output Power versus Frequency

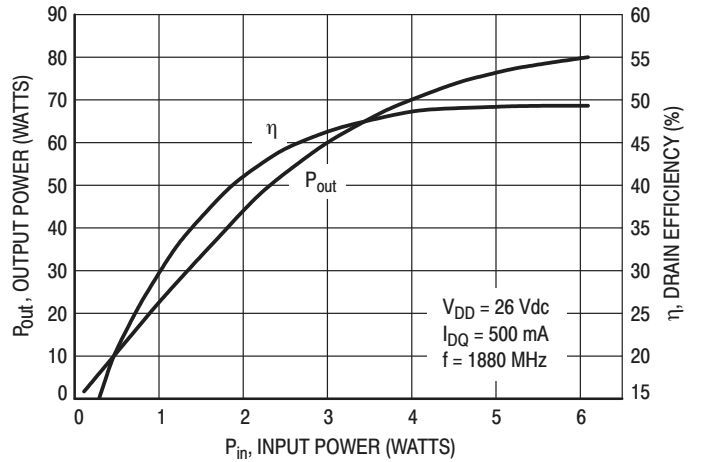

Figure 8. Output Power and Efficiency versus Input Power

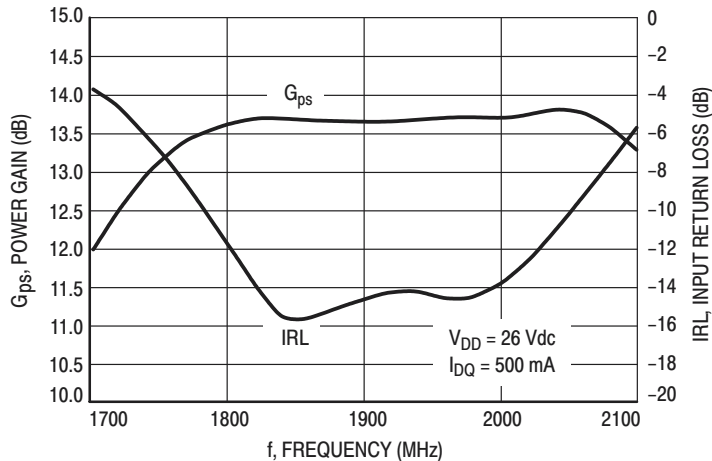
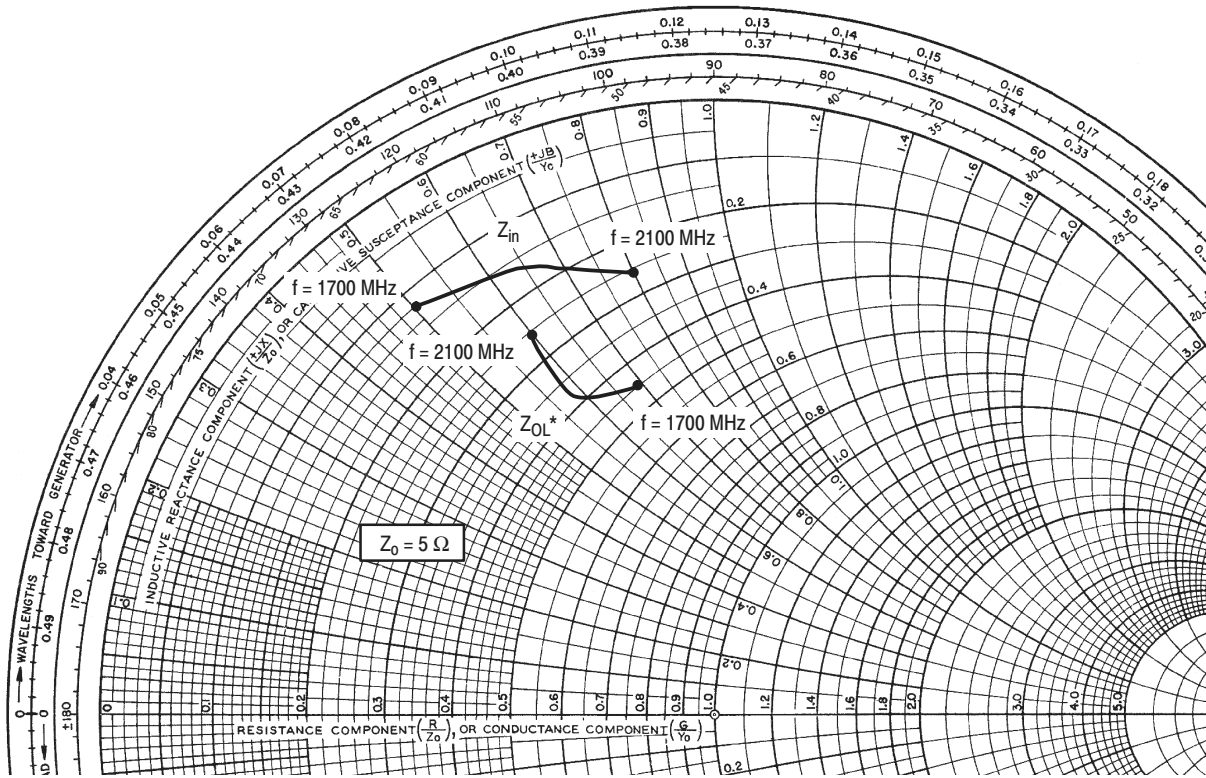

Figure 9. Wideband Gain and IRL (at Small Signal)



$V_{DD} = 26\text{ V}$, $I_{DQ} = 500\text{ mA}$, $P_{out} = 60\text{ W CW}$

f MHz	Z_{in} Ω	Z_{OL}^* Ω
1700	$0.60 + j2.53$	$2.27 + j3.44$
1800	$0.80 + j3.20$	$2.05 + j3.05$
1900	$0.92 + j3.42$	$1.90 + j2.90$
2000	$1.07 + j3.59$	$1.64 + j2.88$
2100	$1.31 + j4.00$	$1.29 + j2.99$

Z_{in} = Complex conjugate of the source impedance.

Z_{OL}^* = Complex conjugate of the optimum load at a given voltage, P1dB, gain, efficiency, bias current and frequency.

Note: Z_{OL}^* was chosen based on tradeoffs between gain, output power, and drain efficiency.

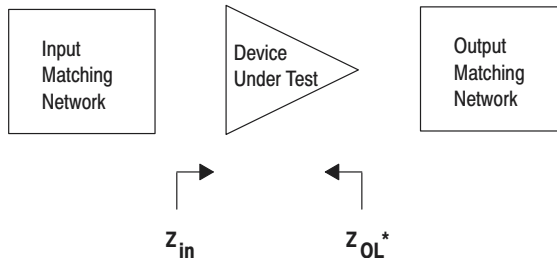
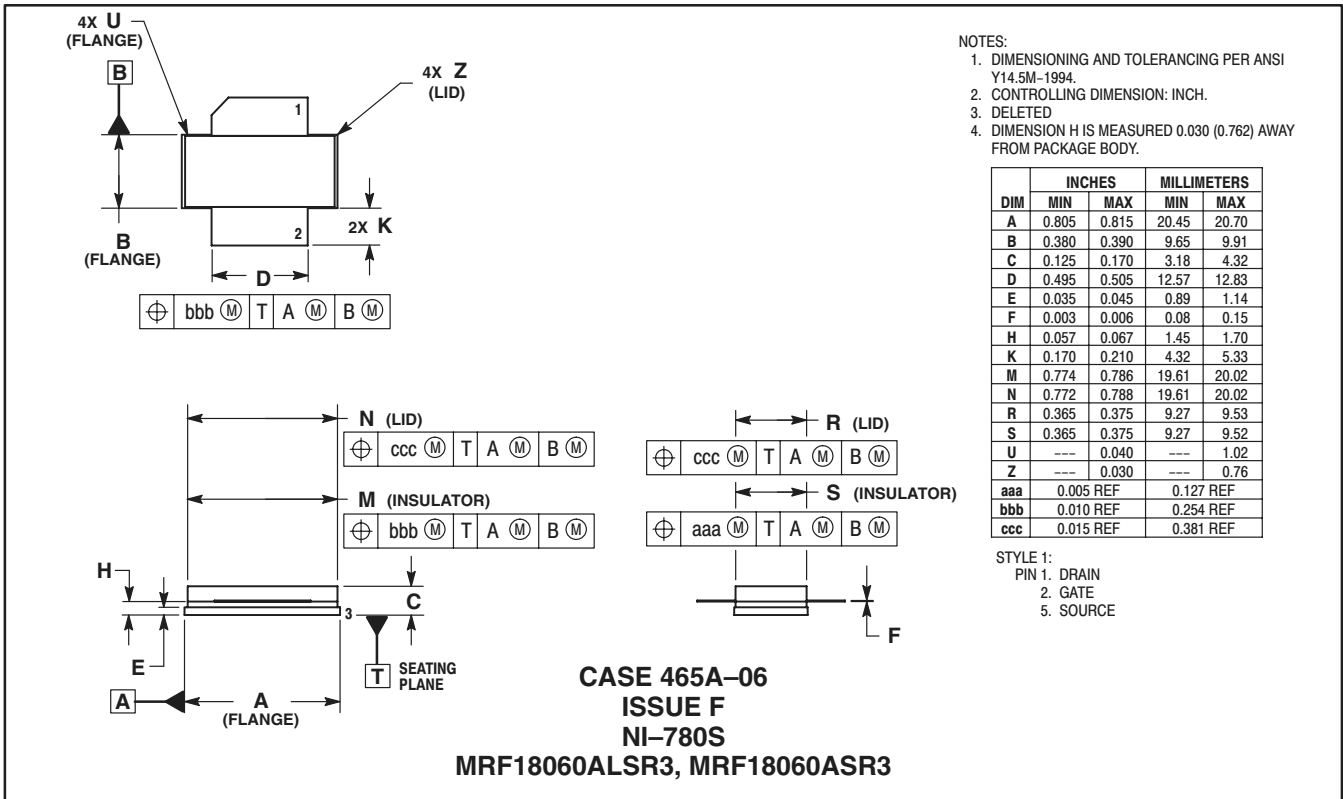
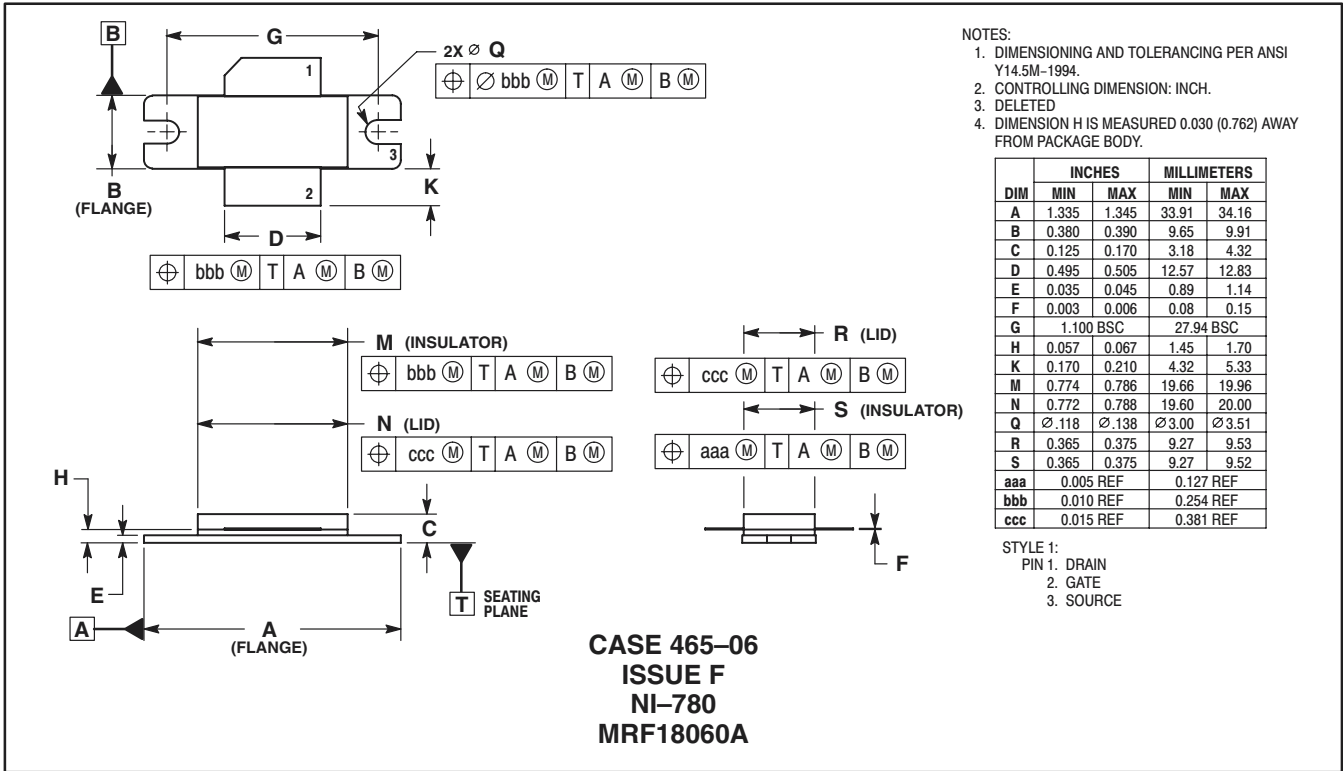



Figure 10. Series Equivalent Input and Output Impedance

PACKAGE DIMENSIONS



Motorola reserves the right to make changes without further notice to any products herein. Motorola makes no warranty, representation or guarantee regarding the suitability of its products for any particular purpose, nor does Motorola assume any liability arising out of the application or use of any product or circuit, and specifically disclaims any and all liability, including without limitation consequential or incidental damages. "Typical" parameters which may be provided in Motorola data sheets and/or specifications can and do vary in different applications and actual performance may vary over time. All operating parameters, including "Typicals" must be validated for each customer application by customer's technical experts. Motorola does not convey any license under its patent rights nor the rights of others. Motorola products are not designed, intended, or authorized for use as components in systems intended for surgical implant into the body, or other applications intended to support or sustain life, or for any other application in which the failure of the Motorola product could create a situation where personal injury or death may occur. Should Buyer purchase or use Motorola products for any such unintended or unauthorized application, Buyer shall indemnify and hold Motorola and its officers, employees, subsidiaries, affiliates, and distributors harmless against all claims, costs, damages, and expenses, and reasonable attorney fees arising out of, directly or indirectly, any claim of personal injury or death associated with such unintended or unauthorized use, even if such claim alleges that Motorola was negligent regarding the design or manufacture of the part. Motorola, Inc. Motorola, Inc. is an Equal Opportunity/Affirmative Action Employer. MOTOROLA and the  logo are registered in the US Patent & Trademark Office. All other product or service names are the property of their respective owners.

© Motorola, Inc. 2002.

How to reach us:

USA/EUROPE/Locations Not Listed: Motorola Literature Distribution; P.O. Box 5405, Denver, Colorado 80217. 1-303-675-2140 or 1-800-441-2447

JAPAN: Motorola Japan Ltd.; SPS, Technical Information Center, 3-20-1, Minami-Azabu. Minato-ku, Tokyo 106-8573 Japan. 81-3-3440-3569

ASIA/PACIFIC: Motorola Semiconductors H.K. Ltd.; Silicon Harbour Centre, 2 Dai King Street, Tai Po Industrial Estate, Tai Po, N.T., Hong Kong. 852-26668334

Technical Information Center: 1-800-521-6274

HOME PAGE: <http://www.motorola.com/semiconductors/>

