



LTC2480

16-Bit $\Delta\Sigma$ ADC with Easy Drive Input Current Cancellation

FEATURES

- Easy Drive Technology Enables Rail-to-Rail Inputs with Zero Differential Input Current
- Directly Digitizes High Impedance Sensors with Full Accuracy
- Programmable Gain from 1 to 256
- Integrated Temperature Sensor
- GND to V_{CC} Input/Reference Common Mode Range
- Programmable 50Hz, 60Hz or Simultaneous 50Hz/60Hz Rejection Mode
- 2ppm (0.25LSB) INL, No Missing Codes
- 1ppm Offset and 15ppm Full-Scale Error
- Selectable 2x Speed Mode (15Hz Using Internal Oscillator)
- No Latency: Digital Filter Settles in a Single Cycle
- Single Supply 2.7V to 5.5V Operation
- Internal Oscillator
- Available in a Tiny (3mm \times 3mm) 10-Lead DFN Package

APPLICATIONS

- Direct Sensor Digitizer
- Weight Scales
- Direct Temperature Measurement
- Strain Gauge Transducers
- Instrumentation
- Industrial Process Control
- DVMs and Meters

DESCRIPTION

The LTC[®]2480 combines a 16-bit plus sign No Latency $\Delta\Sigma$ [™] analog-to-digital converter with patented Easy Drive[™] technology. The patented sampling scheme eliminates dynamic input current errors and the shortcomings of on-chip buffering through automatic cancellation of differential input current. This allows large external source impedances and input signals, with rail-to-rail input range to be directly digitized while maintaining exceptional DC accuracy.

The LTC2480 includes on-chip programmable gain, a temperature sensor and an oscillator. The LTC2480 can be configured to provide a programmable gain from 1 to 256 in 8 steps, measure an external signal or internal temperature sensor and reject line frequencies. 50Hz, 60Hz or simultaneous 50Hz/60Hz line frequency rejection can be selected as well as a 2x speed-up mode.

The LTC2480 allows a wide common mode input range (0V to V_{CC}) independent of the reference voltage. The reference can be as low as 100mV or can be tied directly to V_{CC} . The LTC2480 includes an on-chip trimmed oscillator eliminating the need for external crystals or oscillators. Absolute accuracy and low drift are automatically maintained through continuous, transparent, offset and full-scale calibration.

LT, LTC and LT are registered trademarks of Linear Technology Corporation. No Latency $\Delta\Sigma$ and Easy Drive are trademarks of Linear Technology Corporation. All other trademarks are the property of their respective owners. Patent Pending.

TYPICAL APPLICATION

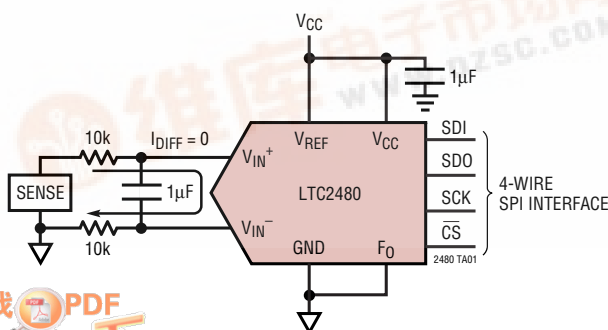

+FS Error vs R_{SOURCE} at IN^+ and IN^-

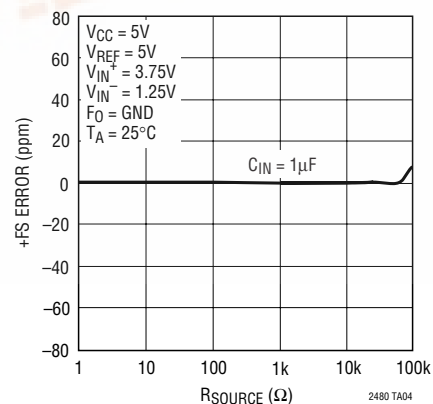

LTC2480

ABSOLUTE MAXIMUM RATINGS

(Notes 1, 2)

Supply Voltage (V_{CC}) to GND	-0.3V to 6V
Analog Input Voltage to GND	-0.3V to ($V_{CC} + 0.3V$)
Reference Input Voltage to GND ..	-0.3V to ($V_{CC} + 0.3V$)
Digital Input Voltage to GND	-0.3V to ($V_{CC} + 0.3V$)
Digital Output Voltage to GND	-0.3V to ($V_{CC} + 0.3V$)
Operating Temperature Range	
LTC2480C	0°C to 70°C
LTC2480I	-40°C to 85°C
Storage Temperature Range	-65°C to 125°C

PACKAGE/ORDER INFORMATION

<p>DD PACKAGE 10-LEAD (3mm × 3mm) PLASTIC DFN</p> <p>$T_{JMAX} = 125^{\circ}C$, $\theta_{JA} = 43^{\circ}C/W$ EXPOSED PAD (PIN 11) IS GND MUST BE SOLDERED TO PCB</p>	ORDER PART NUMBER
	LTC2480CDD LTC2480IDD
	DD PART MARKING*
	LBJY

Consult LTC Marketing for parts specified with wider operating temperature ranges.
*The temperature grade is identified by a label on the shipping container.

ELECTRICAL CHARACTERISTICS (NORMAL SPEED) The ● denotes specifications which apply over the full operating temperature range, otherwise specifications are $T_A = 25^{\circ}C$. (Notes 3, 4)

PARAMETER	CONDITIONS	MIN	TYP	MAX	UNITS
Resolution (No Missing Codes)	$0.1 \leq V_{REF} \leq V_{CC}$, $-FS \leq V_{IN} \leq +FS$ (Note 5)	●	16		Bits
Integral Nonlinearity	$5V \leq V_{CC} \leq 5.5V$, $V_{REF} = 5V$, $V_{IN(CM)} = 2.5V$ (Note 6)	●	2	10	ppm of V_{REF}
	$2.7V \leq V_{CC} \leq 5.5V$, $V_{REF} = 2.5V$, $V_{IN(CM)} = 1.25V$ (Note 6)		1		ppm of V_{REF}
Offset Error	$2.5V \leq V_{REF} \leq V_{CC}$, $GND \leq IN^+ = IN^- \leq V_{CC}$ (Note 14)	●	0.5	2.5	μV
Offset Error Drift	$2.5V \leq V_{REF} \leq V_{CC}$, $GND \leq IN^+ = IN^- \leq V_{CC}$		10		nV/°C
Positive Full-Scale Error	$2.5V \leq V_{REF} \leq V_{CC}$, $IN^+ = 0.75V_{REF}$, $IN^- = 0.25V_{REF}$	●		25	ppm of V_{REF}
Positive Full-Scale Error Drift	$2.5V \leq V_{REF} \leq V_{CC}$, $IN^+ = 0.75V_{REF}$, $IN^- = 0.25V_{REF}$		0.1		ppm of $V_{REF}/^{\circ}C$
Negative Full-Scale Error	$2.5V \leq V_{REF} \leq V_{CC}$, $IN^+ = 0.75V_{REF}$, $IN^- = 0.25V_{REF}$	●		25	ppm of V_{REF}
Negative Full-Scale Error Drift	$2.5V \leq V_{REF} \leq V_{CC}$, $IN^+ = 0.75V_{REF}$, $IN^- = 0.25V_{REF}$		0.1		ppm of $V_{REF}/^{\circ}C$
Total Unadjusted Error	$5V \leq V_{CC} \leq 5.5V$, $V_{REF} = 2.5V$, $V_{IN(CM)} = 1.25V$		15		ppm of V_{REF}
	$5V \leq V_{CC} \leq 5.5V$, $V_{REF} = 5V$, $V_{IN(CM)} = 2.5V$				ppm of V_{REF}
	$2.7V \leq V_{CC} \leq 5.5V$, $V_{REF} = 2.5V$, $V_{IN(CM)} = 1.25V$				ppm of V_{REF}
Output Noise	$5V \leq V_{CC} \leq 5.5V$, $V_{REF} = 5V$, $GND \leq IN^- = IN^+ \leq V_{CC}$ (Note 13)		0.6		μV_{RMS}
Internal PTAT Signal	$T_A = 27^{\circ}C$		420		mV
Internal PTAT Temperature Coefficient			1.4		mV/°C
Programmable Gain		●	1	256	

ELECTRICAL CHARACTERISTICS (2x SPEED)

The ● denotes specifications which apply over the full operating temperature range, otherwise specifications are $T_A = 25^\circ\text{C}$. (Notes 3, 4)

PARAMETER	CONDITIONS	MIN	TYP	MAX	UNITS
Resolution (No Missing Codes)	$0.1 \leq V_{REF} \leq V_{CC}$, $-FS \leq V_{IN} \leq +FS$ (Note 5)	●	16		Bits
Integral Nonlinearity	$5V \leq V_{CC} \leq 5.5V$, $V_{REF} = 5V$, $V_{IN(CM)} = 2.5V$ (Note 6) $2.7V \leq V_{CC} \leq 5.5V$, $V_{REF} = 2.5V$, $V_{IN(CM)} = 1.25V$ (Note 6)	●	2 1	10	ppm of V_{REF}
Offset Error	$2.5V \leq V_{REF} \leq V_{CC}$, $GND \leq IN^+ = IN^- \leq V_{CC}$ (Note 14)	●	0.5	2	mV
Offset Error Drift	$2.5V \leq V_{REF} \leq V_{CC}$, $GND \leq IN^+ = IN^- \leq V_{CC}$		100		nV/ $^\circ\text{C}$
Positive Full-Scale Error	$2.5V \leq V_{REF} \leq V_{CC}$, $IN^+ = 0.75V_{REF}$, $IN^- = 0.25V_{REF}$	●		25	ppm of V_{REF}
Positive Full-Scale Error Drift	$2.5V \leq V_{REF} \leq V_{CC}$, $IN^+ = 0.75V_{REF}$, $IN^- = 0.25V_{REF}$		0.1		ppm of $V_{REF}/^\circ\text{C}$
Negative Full-Scale Error	$2.5V \leq V_{REF} \leq V_{CC}$, $IN^+ = 0.75V_{REF}$, $IN^- = 0.25V_{REF}$	●		25	ppm of V_{REF}
Negative Full-Scale Error Drift	$2.5V \leq V_{REF} \leq V_{CC}$, $IN^+ = 0.75V_{REF}$, $IN^- = 0.25V_{REF}$		0.1		ppm of $V_{REF}/^\circ\text{C}$
Output Noise	$5V \leq V_{CC} \leq 5.5V$, $V_{REF} = 5V$, $GND \leq IN^- = IN^+ \leq V_{CC}$ (Note 13)		0.84		μVRMS
Programmable Gain	(Note 15)	●	1	128	

CONVERTER CHARACTERISTICS

The ● denotes specifications which apply over the full operating temperature range, otherwise specifications are at $T_A = 25^\circ\text{C}$. (Notes 3, 4)

PARAMETER	CONDITIONS	MIN	TYP	MAX	UNITS
Input Common Mode Rejection DC	$2.5V \leq V_{REF} \leq V_{CC}$, $GND \leq IN^- = IN^+ \leq V_{CC}$ (Note 5)	●	140		dB
Input Common Mode Rejection 50Hz $\pm 2\%$	$2.5V \leq V_{REF} \leq V_{CC}$, $GND \leq IN^- = IN^+ \leq V_{CC}$ (Note 5)	●	140		dB
Input Common Mode Rejection 60Hz $\pm 2\%$	$2.5V \leq V_{REF} \leq V_{CC}$, $GND \leq IN^- = IN^+ \leq V_{CC}$ (Note 5)	●	140		dB
Input Normal Mode Rejection 50Hz $\pm 2\%$	$2.5V \leq V_{REF} \leq V_{CC}$, $GND \leq IN^- = IN^+ \leq V_{CC}$ (Notes 5, 7)	●	110	120	dB
Input Normal Mode Rejection 60Hz $\pm 2\%$	$2.5V \leq V_{REF} \leq V_{CC}$, $GND \leq IN^- = IN^+ \leq V_{CC}$ (Notes 5, 8)	●	110	120	dB
Input Normal Mode Rejection 50Hz/60Hz $\pm 2\%$	$2.5V \leq V_{REF} \leq V_{CC}$, $GND \leq IN^- = IN^+ \leq V_{CC}$ (Notes 5, 9)	●	87		dB
Reference Common Mode Rejection DC	$2.5V \leq V_{REF} \leq V_{CC}$, $GND \leq IN^- = IN^+ \leq V_{CC}$ (Note 5)	●	120	140	dB
Power Supply Rejection DC	$V_{REF} = 2.5V$, $IN^- = IN^+ = GND$		120		dB
Power Supply Rejection, 50Hz $\pm 2\%$	$V_{REF} = 2.5V$, $IN^- = IN^+ = GND$ (Notes 7, 9)		120		dB
Power Supply Rejection, 60Hz $\pm 2\%$	$V_{REF} = 2.5V$, $IN^- = IN^+ = GND$ (Notes 8, 9)		120		dB

ANALOG INPUT AND REFERENCE

The ● denotes specifications which apply over the full operating temperature range, otherwise specifications are at $T_A = 25^\circ\text{C}$. (Note 3)

SYMBOL	PARAMETER	CONDITIONS	MIN	TYP	MAX	UNITS
IN^+	Absolute/Common Mode IN^+ Voltage		$GND - 0.3V$		$V_{CC} + 0.3V$	V
IN^-	Absolute/Common Mode IN^- Voltage		$GND - 0.3V$		$V_{CC} + 0.3V$	V
FS	Full Scale of the Differential Input ($IN^+ - IN^-$)	●	$0.5V_{REF}/GAIN$			V
LSB	Least Significant Bit of the Output Code	●	$FS/2^{16}$			
V_{IN}	Input Differential Voltage Range ($IN^+ - IN^-$)	●	-FS		+FS	V
V_{REF}	Reference Voltage Range	●	0.1		V_{CC}	V

LTC2480

ANALOG INPUT AND REFERENCE

The ● denotes specifications which apply over the full operating temperature range, otherwise specifications are at $T_A = 25^\circ\text{C}$. (Note 3)

SYMBOL	PARAMETER	CONDITIONS	MIN	TYP	MAX	UNITS
C_S (IN ⁺)	IN ⁺ Sampling Capacitance			11		pF
C_S (IN ⁻)	IN ⁻ Sampling Capacitance			11		pF
C_S (V _{REF})	V _{REF} Sampling Capacitance			11		pF
I_{DC_LEAK} (IN ⁺)	IN ⁺ DC Leakage Current	Sleep Mode, IN ⁺ = GND ●	-10	1	10	nA
I_{DC_LEAK} (IN ⁻)	IN ⁻ DC Leakage Current	Sleep Mode, IN ⁻ = GND ●	-10	1	10	nA
I_{DC_LEAK} (V _{REF})	V _{REF} DC Leakage Current	Sleep Mode, V _{REF} = V _{CC} ●	-100	1	100	nA

DIGITAL INPUTS AND DIGITAL OUTPUTS

The ● denotes specifications which apply over the full operating temperature range, otherwise specifications are at $T_A = 25^\circ\text{C}$. (Note 3)

SYMBOL	PARAMETER	CONDITIONS	MIN	TYP	MAX	UNITS
V_{IH}	High Level Input Voltage CS, F _O , SDI	$2.7V \leq V_{CC} \leq 5.5V$ ●	$V_{CC} - 0.5$			V
V_{IL}	Low Level Input Voltage CS, F _O , SDI	$2.7V \leq V_{CC} \leq 5.5V$ ●			0.5	V
V_{IH}	High Level Input Voltage SCK	$2.7V \leq V_{CC} \leq 5.5V$ (Note 10) ●	$V_{CC} - 0.5$			V
V_{IL}	Low Level Input Voltage SCK	$2.7V \leq V_{CC} \leq 5.5V$ (Note 10) ●			0.5	V
I_{IN}	Digital Input Current CS, F _O , SDI	$0V \leq V_{IN} \leq V_{CC}$ ●	-10		10	μA
I_{IN}	Digital Input Current SCK	$0V \leq V_{IN} \leq V_{CC}$ (Note 10) ●	-10		10	μA
C_{IN}	Digital Input Capacitance CS, F _O , SDI			10		pF
C_{IN}	Digital Input Capacitance SCK			10		pF
V_{OH}	High Level Output Voltage SDO	$I_O = -800\mu A$ ●	$V_{CC} - 0.5$			V
V_{OL}	Low Level Output Voltage SDO	$I_O = 1.6mA$ ●			0.4	V
V_{OH}	High Level Output Voltage SCK	$I_O = -800\mu A$ ●	$V_{CC} - 0.5$			V
V_{OL}	Low Level Output Voltage SCK	$I_O = 1.6mA$ ●			0.4	V
I_{OZ}	Hi-Z Output Leakage SDO	●	-10		10	μA

POWER REQUIREMENTS

The ● denotes specifications which apply over the full operating temperature range, otherwise specifications are at $T_A = 25^\circ\text{C}$. (Note 3)

SYMBOL	PARAMETER	CONDITIONS	MIN	TYP	MAX	UNITS
V_{CC}	Supply Voltage	●	2.7		5.5	V
I_{CC}	Supply Current	Conversion Mode (Note 12) ●		160	250	μA
		Sleep Mode (Note 12) ●		1	2	μA

TIMING CHARACTERISTICS

The ● denotes specifications which apply over the full operating temperature range, otherwise specifications are at $T_A = 25^\circ\text{C}$. (Note 3)

SYMBOL	PARAMETER	CONDITIONS	MIN	TYP	MAX	UNITS	
f_{EOSC}	External Oscillator Frequency Range	(Note 15)	●	10	4000	kHz	
t_{HEO}	External Oscillator High Period		●	0.125	100	μs	
t_{LEO}	External Oscillator Low Period		●	0.125	100	μs	
t_{CONV_1}	Conversion Time for 1x Speed Mode	50Hz Mode	●	157.2	160.3	163.5	ms
		60Hz Mode	●	131.0	133.6	136.3	ms
		Simultaneous 50Hz/60Hz Mode	●	144.1	146.9	149.9	ms
		External Oscillator	●	41036/ f_{EOSC} (in kHz)			ms
t_{CONV_2}	Conversion Time for 2x Speed Mode	50Hz Mode	●	78.7	80.3	81.9	ms
		60Hz Mode	●	65.6	66.9	68.2	ms
		Simultaneous 50Hz/60Hz Mode	●	72.2	73.6	75.1	ms
		External Oscillator	●	20556/ f_{EOSC} (in kHz)			ms
f_{ISCK}	Internal SCK Frequency	Internal Oscillator (Note 10)		38.4		kHz	
		External Oscillator (Notes 10, 11)		$f_{\text{EOSC}}/8$		kHz	
D_{ISCK}	Internal SCK Duty Cycle	(Note 10)	●	45	55	%	
f_{ESCK}	External SCK Frequency Range	(Note 10)	●		4000	kHz	
t_{LESCK}	External SCK Low Period	(Note 10)	●	125		ns	
t_{HESCK}	External SCK High Period	(Note 10)	●	125		ns	
$t_{\text{DOUT_ISCK}}$	Internal SCK 24-Bit Data Output Time	Internal Oscillator (Notes 10, 12)	●	0.61	0.625	0.64	ms
		External Oscillator (Notes 10, 11)	●	192/ f_{EOSC} (in kHz)			ms
$t_{\text{DOUT_ESCK}}$	External SCK 24-Bit Data Output Time	(Note 10)	●	24/ f_{ESCK} (in kHz)			ms
t_1	$\overline{\text{CS}}\downarrow$ to SDO Low		●	0	200	ns	
t_2	$\overline{\text{CS}}\uparrow$ to SDO High Z		●	0	200	ns	
t_3	$\overline{\text{CS}}\downarrow$ to SCK \downarrow	Internal SCK Mode	●	0	200	ns	
t_4	$\overline{\text{CS}}\downarrow$ to SCK \uparrow	External SCK Mode	●	50		ns	
t_{KQMAX}	SCK \downarrow to SDO Valid		●		200	ns	
t_{KQMIN}	SDO Hold After SCK \downarrow	(Note 5)	●	15		ns	
t_5	SCK Set-Up Before $\overline{\text{CS}}\downarrow$		●	50		ns	
t_6	SCK Hold After $\overline{\text{CS}}\downarrow$		●		50	ns	
t_7	SDI Setup Before SCK \uparrow	(Note 5)	●	100		ns	
t_8	SDI Hold After SCK \uparrow	(Note 5)	●	100		ns	

Note 1: Absolute Maximum Ratings are those values beyond which the life of the device may be impaired.

Note 2: All voltage values are with respect to GND.

Note 3: $V_{\text{CC}} = 2.7\text{V}$ to 5.5V unless otherwise specified.

$$V_{\text{REFCM}} = V_{\text{REF}}/2, \text{FS} = 0.5V_{\text{REF}}/\text{GAIN}$$

$$V_{\text{IN}} = \text{IN}^+ - \text{IN}^-, V_{\text{IN(CM)}} = (\text{IN}^+ + \text{IN}^-)/2$$

Note 4: Use internal conversion clock or external conversion clock source with $f_{\text{EOSC}} = 307.2\text{kHz}$ unless otherwise specified.

Note 5: Guaranteed by design, not subject to test.

Note 6: Integral nonlinearity is defined as the deviation of a code from a straight line passing through the actual endpoints of the transfer curve. The deviation is measured from the center of the quantization band.

Note 7: 50Hz mode (internal oscillator) or $f_{\text{EOSC}} = 256\text{kHz} \pm 2\%$ (external oscillator).

Note 8: 60Hz mode (internal oscillator) or $f_{\text{EOSC}} = 307.2\text{kHz} \pm 2\%$ (external oscillator).

Note 9: Simultaneous 50Hz/60Hz mode (internal oscillator) or $f_{\text{EOSC}} = 280\text{kHz} \pm 2\%$ (external oscillator).

Note 10: The SCK can be configured in external SCK mode or internal SCK mode. In external SCK mode, the SCK pin is used as digital input and the driving clock is f_{ESCK} . In internal SCK mode, the SCK pin is used as digital output and the output clock signal during the data output is f_{ISCK} .

Note 11: The external oscillator is connected to the F_0 pin. The external oscillator frequency, f_{EOSC} , is expressed in kHz.

Note 12: The converter uses the internal oscillator.

Note 13: The output noise includes the contribution of the internal calibration operations.

Note 14: Guaranteed by design and test correlation.

Note 15: Refer to Applications Information section for performance vs data rate graphs.

TYPICAL PERFORMANCE CHARACTERISTICS

Integral Nonlinearity
($V_{CC} = 5V$, $V_{REF} = 5V$)

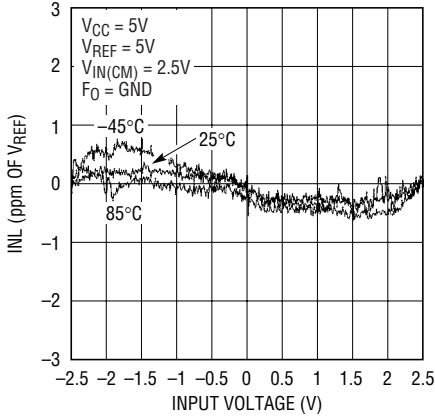

2480 G04

Integral Nonlinearity
($V_{CC} = 5V$, $V_{REF} = 2.5V$)

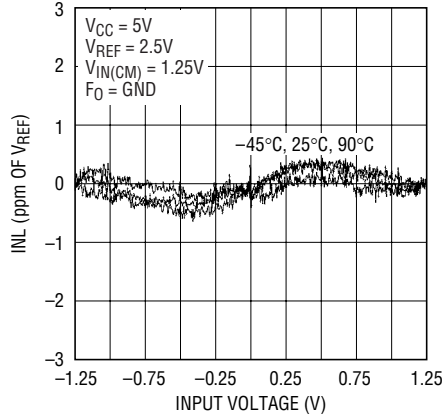

2480 G05

Integral Nonlinearity
($V_{CC} = 2.7V$, $V_{REF} = 2.5V$)

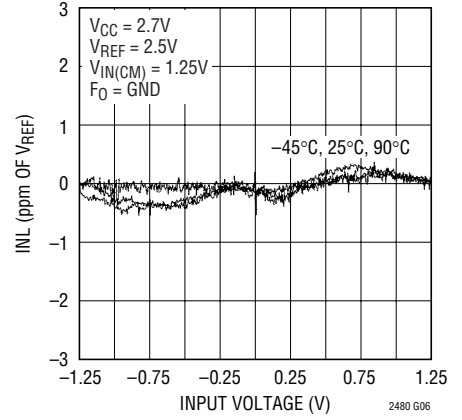

2480 G06

Total Unadjusted Error
($V_{CC} = 5V$, $V_{REF} = 5V$)

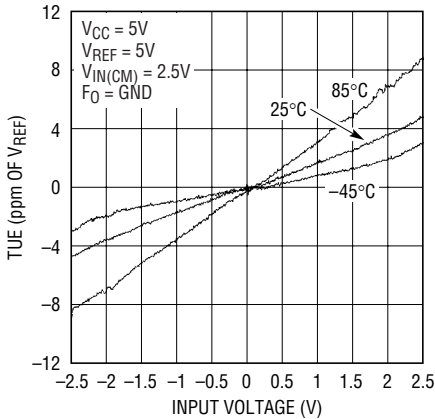

2480 G01

Total Unadjusted Error
($V_{CC} = 5V$, $V_{REF} = 2.5V$)

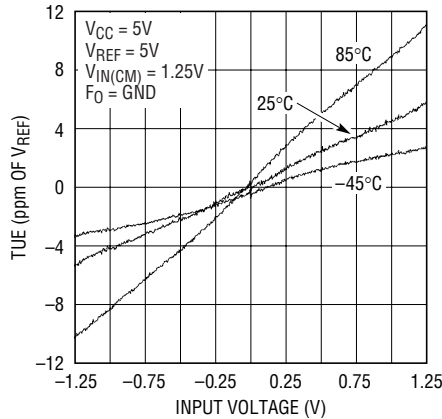

2480 G02

Total Unadjusted Error
($V_{CC} = 2.7V$, $V_{REF} = 2.5V$)

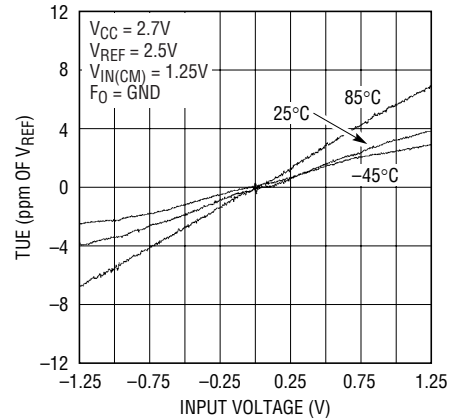

2480 G03

Noise Histogram (6.8sps)

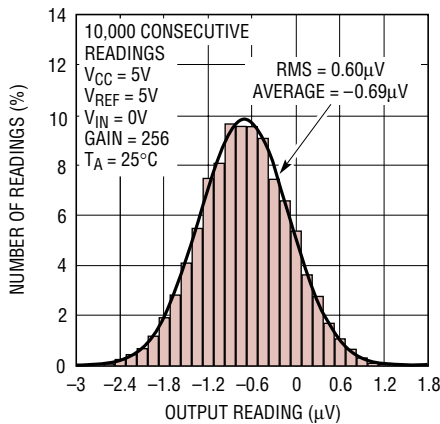

2480 G07

Noise Histogram (7.5sps)

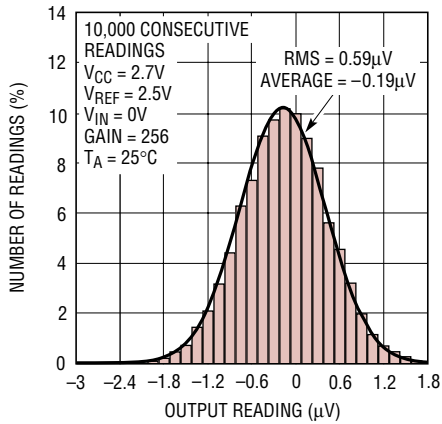

2480 G08

Long-Term ADC Readings

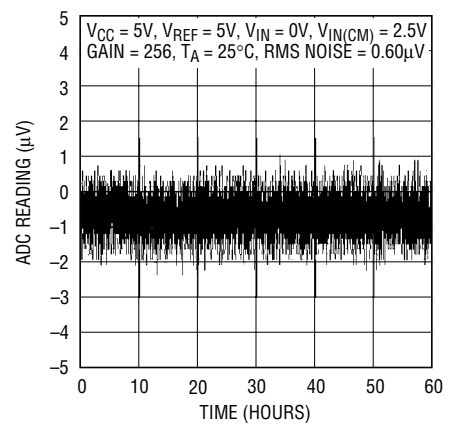

2480 G09

TYPICAL PERFORMANCE CHARACTERISTICS

RMS Noise vs Input Differential Voltage

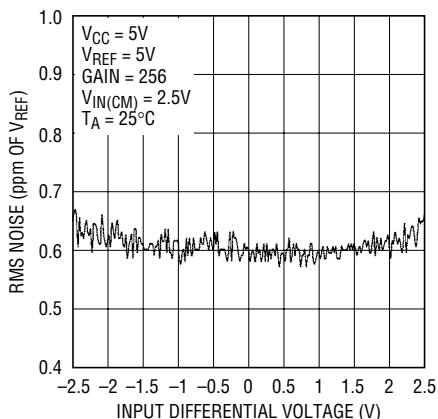

2480 G10

RMS Noise vs $V_{IN(CM)}$

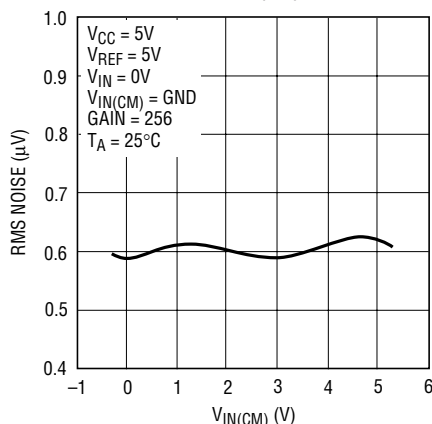

2480 G11

RMS Noise vs Temperature (T_A)

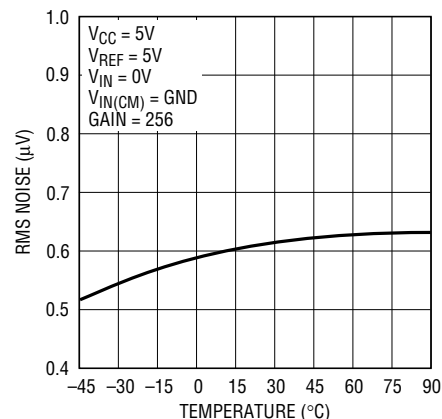

2480 G12

RMS Noise vs V_{CC}

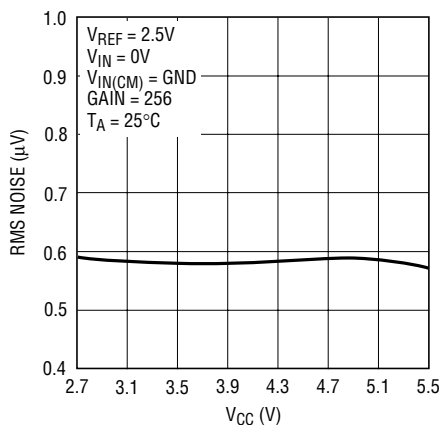

2480 G13

RMS Noise vs V_{REF}

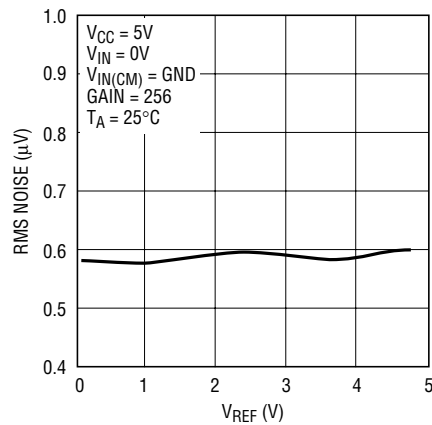

2480 G14

Offset Error vs $V_{IN(CM)}$

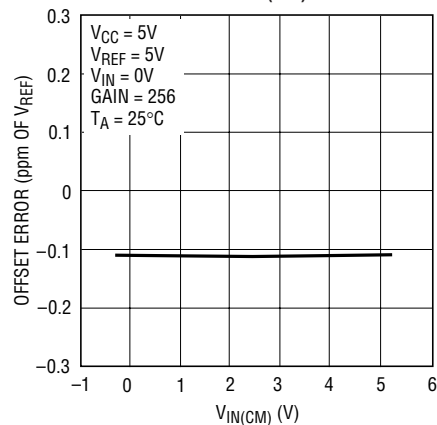

2480 G15

Offset Error vs Temperature

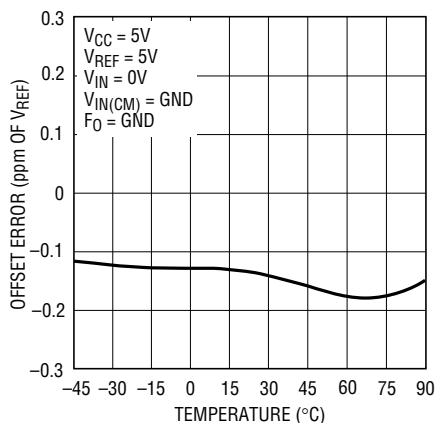

2480 G16

Offset Error vs V_{CC}

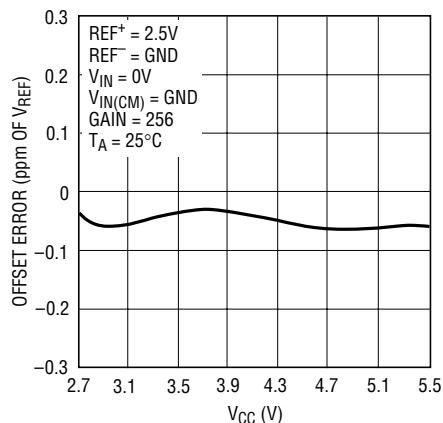

2480 G17

Offset Error vs V_{REF}

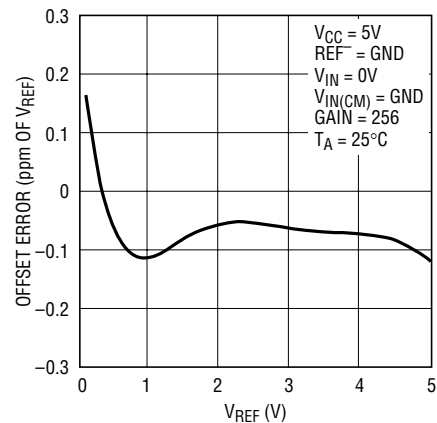

2480 G18

TYPICAL PERFORMANCE CHARACTERISTICS

Temperature Sensor vs Temperature

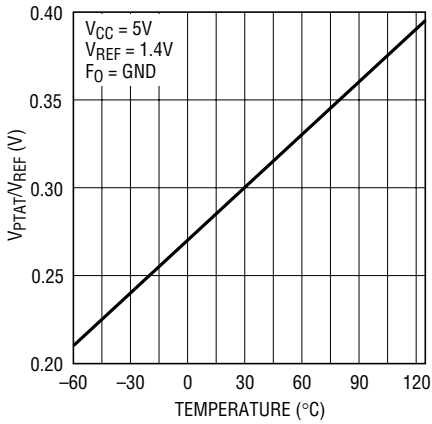

2480 G24

Temperature Sensor Error vs Temperature

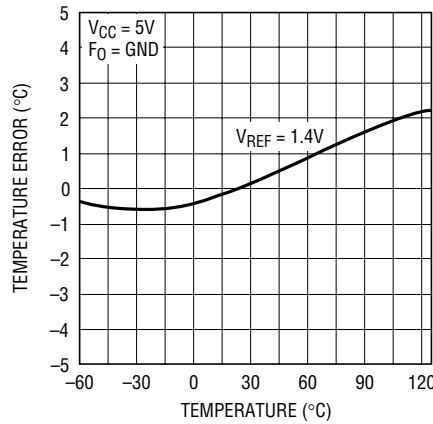

2480 G25

On-Chip Oscillator Frequency vs Temperature

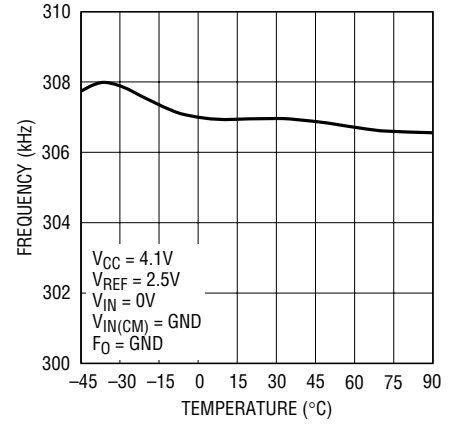

2480 G26

On-Chip Oscillator Frequency vs VCC

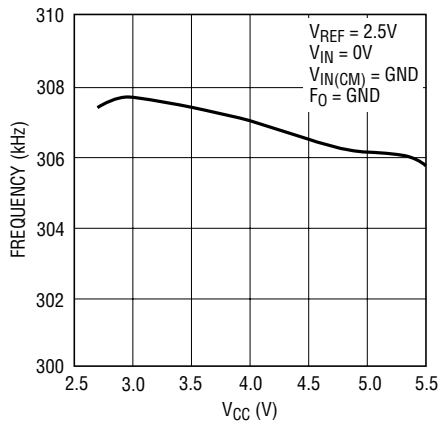

2480 G27

PSRR vs Frequency at VCC

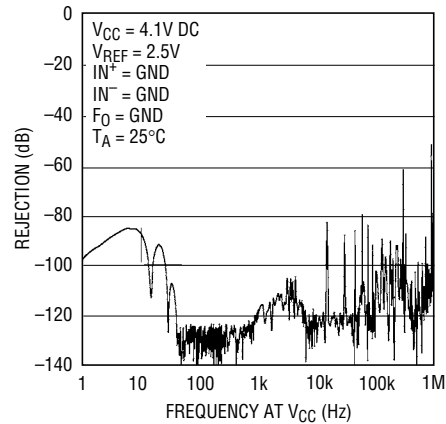

2480 G28

PSRR vs Frequency at VCC

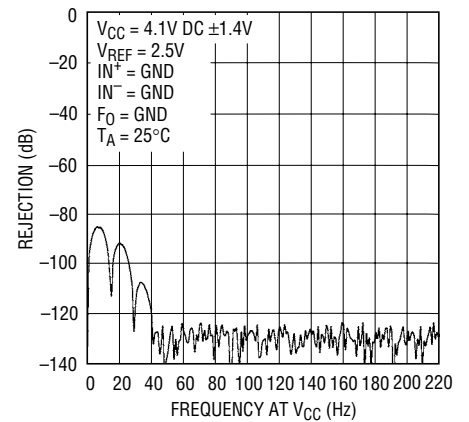

2480 G29

PSRR vs Frequency at VCC

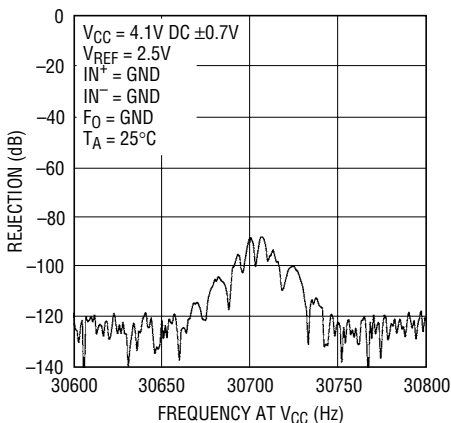

2480 G30

Conversion Current vs Temperature

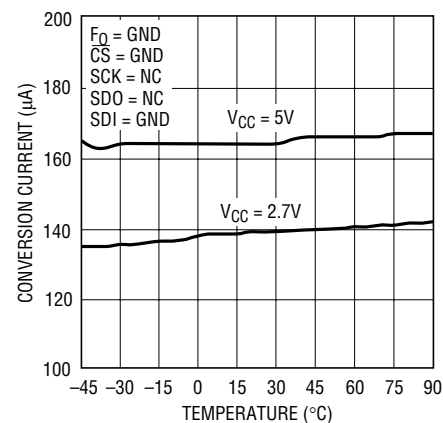

2480 G31

Sleep Mode Current vs Temperature

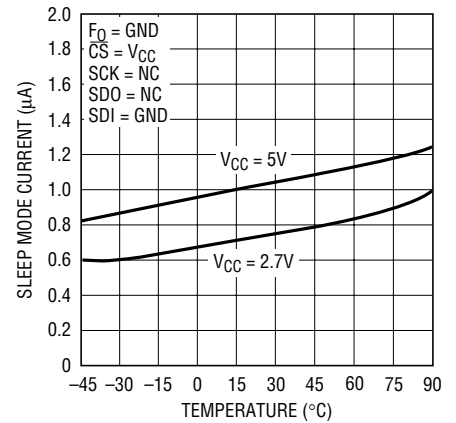

2480 G32

TYPICAL PERFORMANCE CHARACTERISTICS

Conversion Current vs Output Data Rate

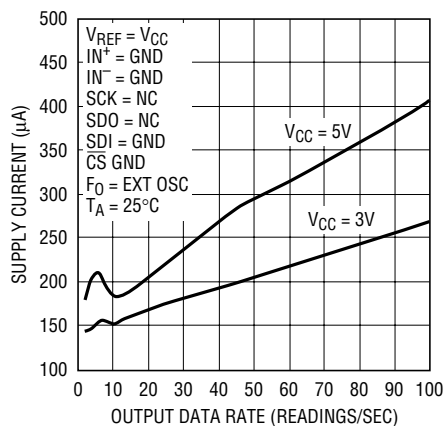

2480 G33

Integral Nonlinearity (2x Speed Mode; VCC = 5V, VREF = 5V)

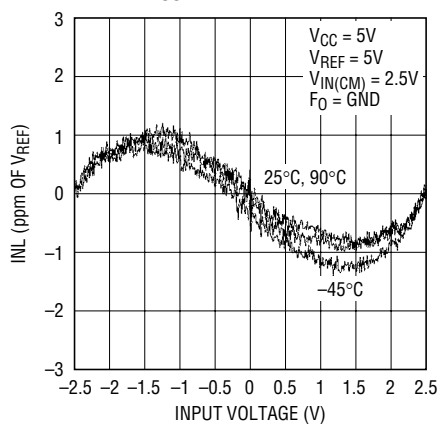

2480 G34

Integral Nonlinearity (2x Speed Mode; VCC = 5V, VREF = 2.5V)

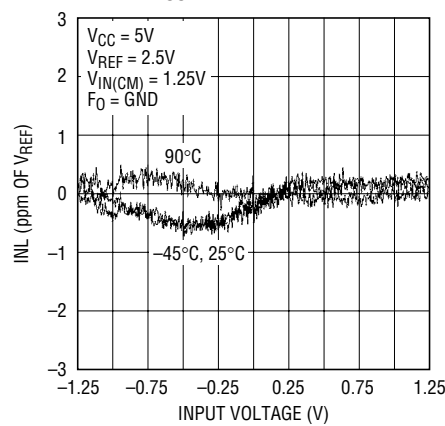

2480 G35

Integral Nonlinearity (2x Speed Mode; VCC = 2.7V, VREF = 2.5V)

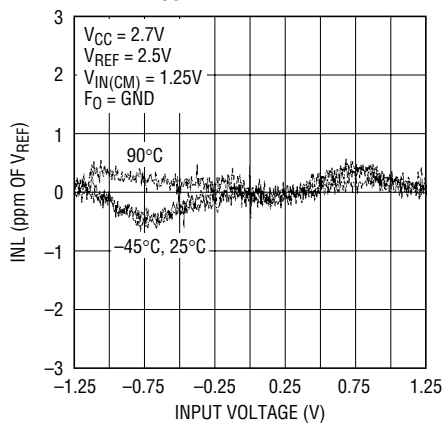

2480 G36

Noise Histogram (2x Speed Mode)

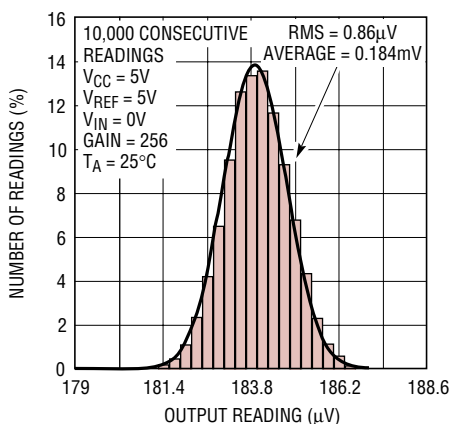

2480 G37

RMS Noise vs VREF (2x Speed Mode)

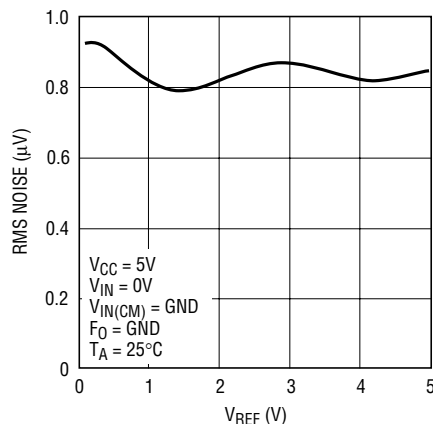

2480 G38

Offset Error vs VIN(CM) (2x Speed Mode)

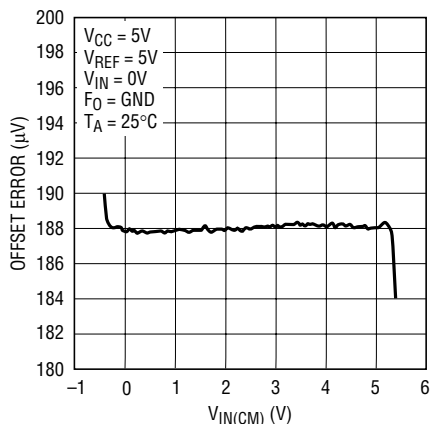

2480 G39

Offset Error vs Temperature (2x Speed Mode)

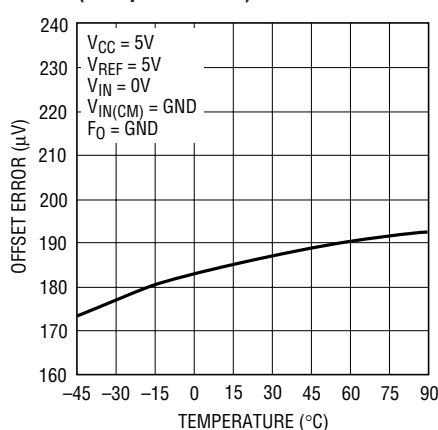

2480 G40

TYPICAL PERFORMANCE CHARACTERISTICS

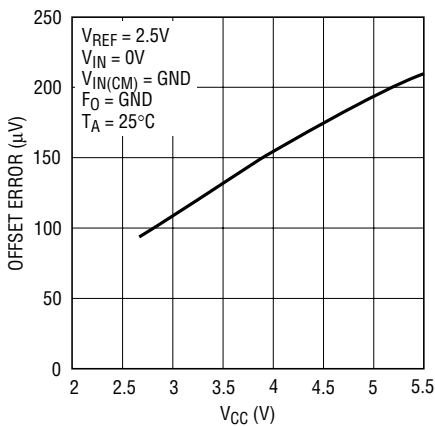
Offset Error vs V_{CC}
(2x Speed Mode)

2480 G41

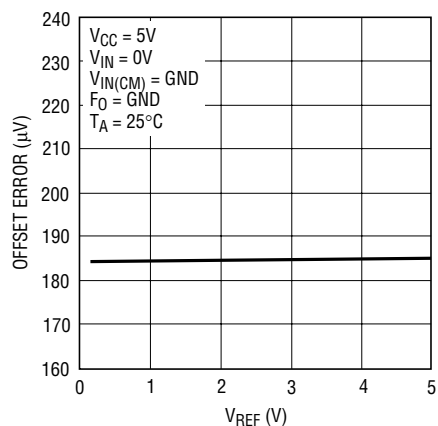
Offset Error vs V_{REF}
(2x Speed Mode)

2480 G42

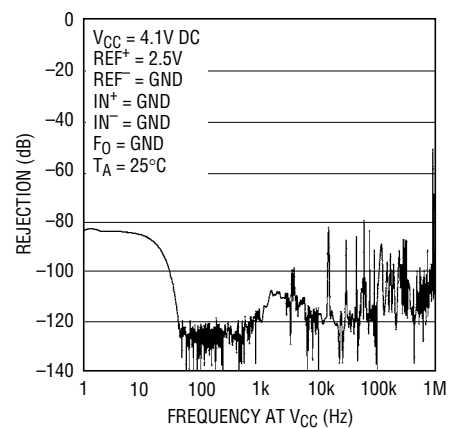
PSRR vs Frequency at V_{CC}
(2x Speed Mode)

2480 G43

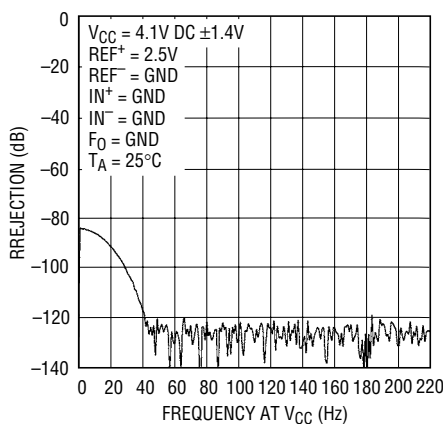
PSRR vs Frequency at V_{CC}
(2x Speed Mode)

2480 G44

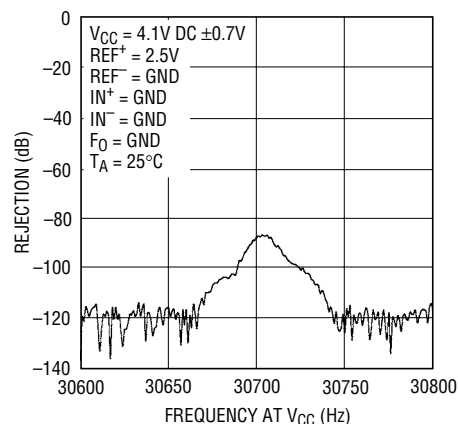
PSRR vs Frequency at V_{CC}
(2x Speed Mode)

2480 G45

PIN FUNCTIONS

SDI (Pin 1): Serial Data Input. This pin is used to select the GAIN, line frequency rejection, input, temperature sensor and 2x speed mode. Data is shifted into the SDI pin on the rising edge of serial clock (SCK).

V_{CC} (Pin 2): Positive Supply Voltage. Bypass to GND (Pin 8) with a $1\mu\text{F}$ tantalum capacitor in parallel with $0.1\mu\text{F}$ ceramic capacitor as close to the part as possible.

V_{REF} (Pin 3): Positive Reference Input. The voltage on this pin can have any value between 0.1V and V_{CC} . The negative reference input is GND (Pin 8).

IN^+ (Pin 4), IN^- (Pin 5): Differential Analog Inputs. The voltage on these pins can have any value between $\text{GND} - 0.3\text{V}$ and $V_{CC} + 0.3\text{V}$. Within these limits the converter bipolar input range ($V_{IN} = IN^+ - IN^-$) extends from $-0.5 \cdot V_{REF}/\text{GAIN}$ to $0.5 \cdot V_{REF}/\text{GAIN}$. Outside this input range the converter produces unique overrange and underrange output codes.

$\overline{\text{CS}}$ (Pin 6): Active LOW Chip Select. A LOW on this pin enables the digital input/output and wakes up the ADC. Following each conversion the ADC automatically enters the Sleep mode and remains in this low power state as long

PIN FUNCTIONS

as \overline{CS} is HIGH. A LOW-to-HIGH transition on \overline{CS} during the Data Output transfer aborts the data transfer and starts a new conversion.

SDO (Pin 7): Three-State Digital Output. During the Data Output period, this pin is used as the serial data output. When the chip select \overline{CS} is HIGH ($\overline{CS} = V_{CC}$), the SDO pin is in a high impedance state. During the Conversion and Sleep periods, this pin is used as the conversion status output. The conversion status can be observed by pulling \overline{CS} LOW.

GND (Pin 8): Ground. Shared pin for analog ground, digital ground and reference ground. Should be connected directly to a ground plane through a minimum impedance.

SCK (Pin 9): Bidirectional Digital Clock Pin. In Internal Serial Clock Operation mode, SCK is used as the digital output for the internal serial interface clock during the Data

Input/Output period. In External Serial Clock Operation mode, SCK is used as the digital input for the external serial interface clock during the Data Output period. A weak internal pull-up is automatically activated in Internal Serial Clock Operation mode. The Serial Clock Operation mode is determined by the logic level applied to the SCK pin at power up or during the most recent falling edge of \overline{CS} .

F₀ (Pin 10): Frequency Control Pin. Digital input that controls the conversion clock. When F₀ is connected to GND the converter uses its internal oscillator running at 307.2kHz. The conversion clock may also be overridden by driving the F₀ pin with an external clock in order to change the output rate or the digital filter rejection null.

Exposed Pad (Pin 11): This pin is ground and should be soldered to the PCB ground plane. For prototyping purposes, this pin may remain floating.

FUNCTIONAL BLOCK DIAGRAM

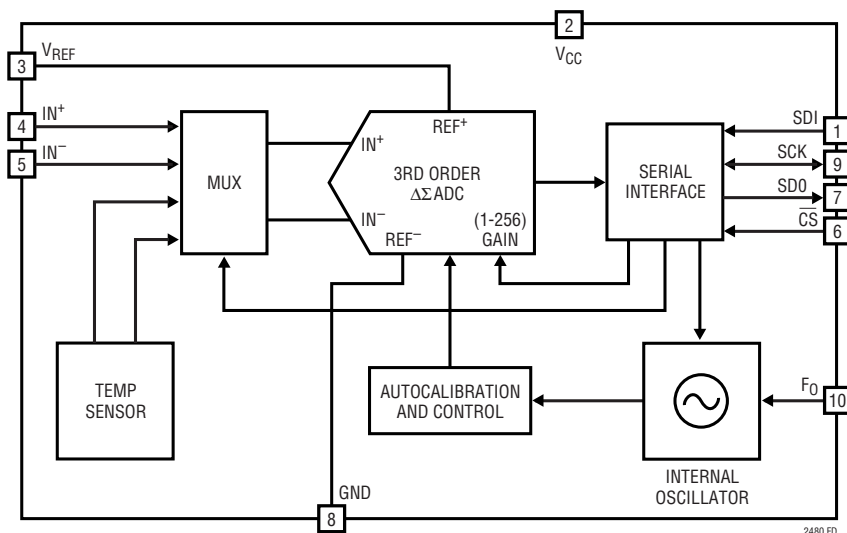

TEST CIRCUITS

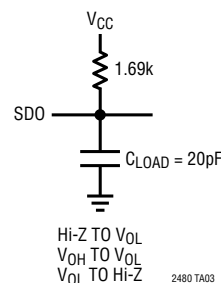
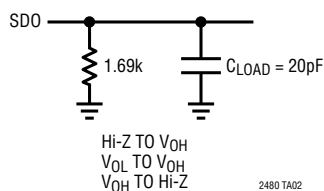

TIMING DIAGRAMS

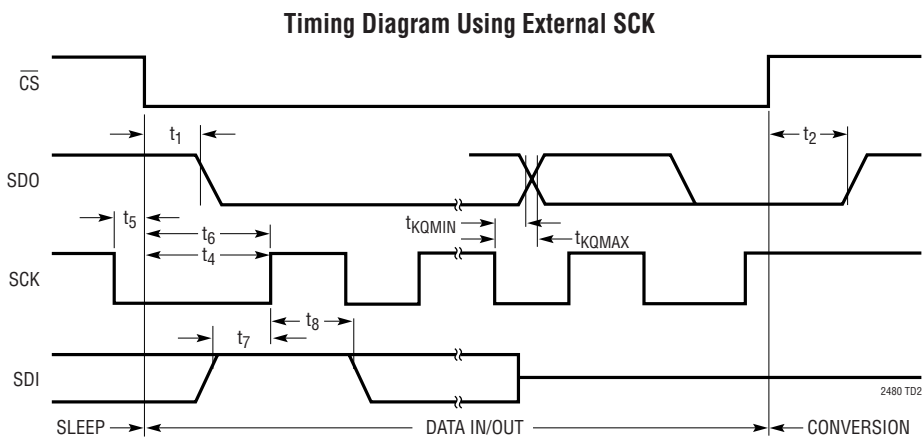
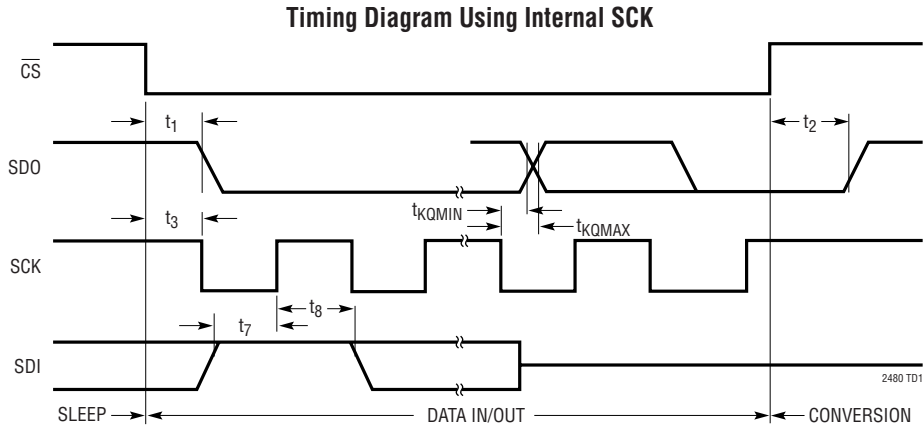

APPLICATIONS INFORMATION

CONVERTER OPERATION

Converter Operation Cycle

The LTC2480 is a low power, delta-sigma analog-to-digital converter with an easy to use 4-wire serial interface and automatic differential input current cancellation. Its operation is made up of three states. The converter operating cycle begins with the conversion, followed by the low power sleep state and ends with the data output (see Figure 1). The 4-wire interface consists of serial data output (SDO), serial clock (SCK), chip select ($\overline{\text{CS}}$) and serial data input (SDI).

Initially, the LTC2480 performs a conversion. Once the conversion is complete, the device enters the sleep state.

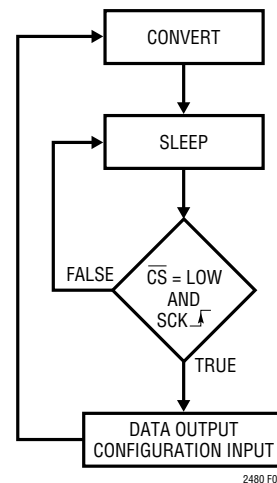

Figure 1. LTC2480 State Transition Diagram

APPLICATIONS INFORMATION

While in this sleep state, power consumption is reduced by two orders of magnitude. The part remains in the sleep state as long as \overline{CS} is HIGH. The conversion result is held indefinitely in a static shift register while the converter is in the sleep state.

Once \overline{CS} is pulled LOW, the device exits the low power mode and enters the data output state. If \overline{CS} is pulled HIGH before the first rising edge of SCK, the device returns to the low power sleep mode and the conversion result is still held in the internal static shift register. If \overline{CS} remains LOW after the first rising edge of SCK, the device begins outputting the conversion result. Taking \overline{CS} high at this point will terminate the data input and output state and start a new conversion. The conversion result is shifted out of the device through the serial data output pin (SDO) on the falling edge of the serial clock (SCK) (see Figure 2). The LTC2480 includes a serial data input pin (SDI) in which data is latched by the device on the rising edge of SCK (Figure 2). The bit stream applied to this pin can be used to select various features of the LTC2480, including an on-chip temperature sensor, programmable GAIN, line frequency rejection and output data rate. Alternatively, this pin may be tied to ground and the part will perform conversions in a default state. In the default state (SDI grounded) the device simply performs conversions on the user applied input with a GAIN of 1 and simultaneous rejection of 50Hz and 60Hz line frequencies.

Through timing control of the \overline{CS} and SCK pins, the LTC2480 offers several flexible modes of operation (internal or external SCK and free-running conversion modes). These various modes do not require programming configuration registers; moreover, they do not disturb the cyclic operation described above. These modes of operation are described in detail in the Serial Interface Timing Modes section.

Easy Drive Input Current Cancellation

The LTC2480 combines a high precision delta-sigma ADC with an automatic differential input current cancellation front end. A proprietary front-end passive sampling

network transparently removes the differential input current. This enables external RC networks and high impedance sensors to directly interface to the LTC2480 without external amplifiers. The remaining common mode input current is eliminated by either balancing the differential input impedances or setting the common mode input equal to the common mode reference (see Automatic Input Current Cancellation section). This unique architecture does not require on-chip buffers enabling input signals to swing all the way to ground and up to V_{CC} . Furthermore, the cancellation does not interfere with the transparent offset and full-scale auto-calibration and the absolute accuracy (full scale + offset + linearity) is maintained even with external RC networks.

Accessing the Special Features of the LTC2480

The LTC2480 combines a high resolution, low noise $\Delta\Sigma$ analog-to-digital converter with an on-chip selectable temperature sensor, programmable gain, programmable digital filter and output rate control. These special features are selected through a single 8-bit serial input word during the data input/output cycle (see Figure 2).

The LTC2480 powers up in a default mode commonly used for most measurements. The device will remain in this mode as long as the serial data input (SDI) is low. In this default mode, the measured input is external, the GAIN is 1, the digital filter simultaneously rejects 50Hz and 60Hz line frequency noise, and the speed mode is 1x (offset automatically, continuously calibrated).

A simple serial interface grants access to any or all special functions contained within the LTC2480. In order to change the mode of operation, an enable bit (EN) followed by up to 7 bits of data are shifted into the device (see Table 1). The first 3 bits (GS2, GS1, GS0) control the GAIN of the converter from 1 to 256. The 4th bit (IM) is used to select the internal temperature sensor as the conversion input, while the 5th and 6th bits (FA, FB) combine to determine the line frequency rejection mode. The 7th bit (SPD) is used to double the output rate by disabling the offset auto calibration.

APPLICATIONS INFORMATION

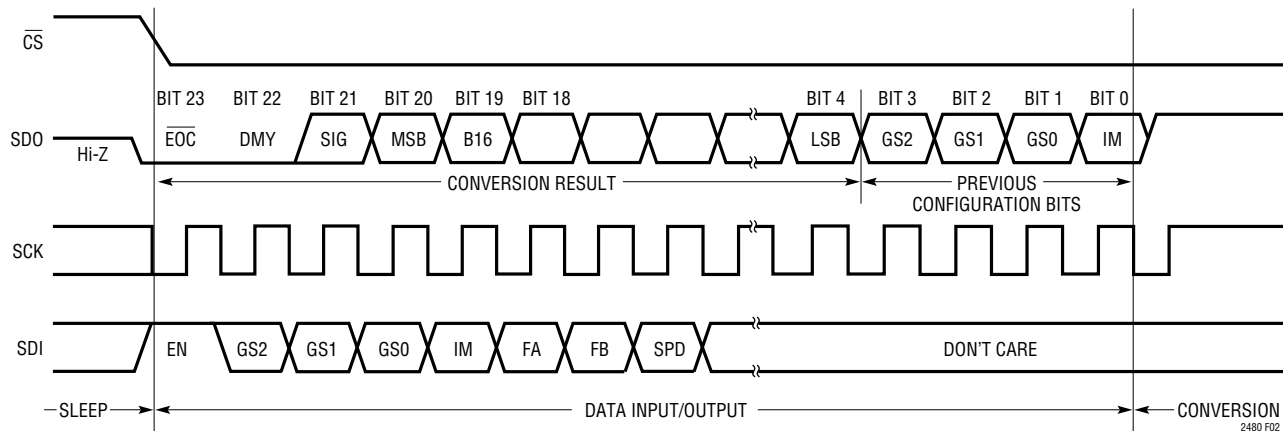

Figure 2. Input/Output Data Timing

Table 1. Selecting Special Modes

	Gain				Rejection Mode				Comments	
	EN	GS2	GS1	GS0	IM	FA	FB	SPD		
0	X	X	X	X	X	X	X	X	Keep Previous Mode	
1	0	0	0	0	0			0	External Input, Gain = 1, Autocalibration	
1	0	0	1	0	0			0	External Input, Gain = 4, Autocalibration	
1	0	1	0	0	0			0	External Input, Gain = 8, Autocalibration	
1	0	1	1	0	0			0	External Input, Gain = 16, Autocalibration	
1	1	0	0	0	0			0	External Input, Gain = 32, Autocalibration	
1	1	0	1	0	0			0	External Input, Gain = 64, Autocalibration	
1	1	1	0	0	0			0	External Input, Gain = 128, Autocalibration	
1	1	1	1	0	0			0	External Input, Gain = 256, Autocalibration	
1	0	0	0	0				1	Any Rejection Mode	
1	0	0	1	0				1		External Input, Gain = 1, 2x Speed
1	0	1	0	0				1		External Input, Gain = 2, 2x Speed
1	0	1	1	0				1		External Input, Gain = 4, 2x Speed
1	1	0	0	0				1		External Input, Gain = 8, 2x Speed
1	1	0	1	0				1		External Input, Gain = 16, 2x Speed
1	1	1	0	0				1		External Input, Gain = 32, 2x Speed
1	1	1	1	0				1		External Input, Gain = 64, 2x Speed
1	1	1	1	0				1	External Input, Gain = 128, 2x Speed	
1					0	0	0		External Input, Simultaneous 50Hz/60Hz Rejection	
1					0	0	1	Any Speed	External Input, 50Hz Rejection	
1					0	1	0	Any Speed	External Input, 60Hz Rejection	
1					0	1	1		Reserved, Do Not Use	
1	X	X	X	1	0	0		X	Temperature Input, 50Hz/60Hz Rejection, Gain = 1, Autocalibration	
1	X	X	X	1	0	1		X	Temperature Input, 50Hz Rejection, Gain = 1, Autocalibration	
1	X	X	X	1	1	0		X	Temperature Input, 60Hz Rejection, Gain = 1, Autocalibration	
1	X	X	X	1	1	1		X	Reserved, Do Not Use	

2480 TBL1

APPLICATIONS INFORMATION

Table 2a. The LTC2480 Performance vs GAIN in Normal Speed Mode ($V_{CC} = 5V$, $V_{REF} = 5V$)

GAIN	1	4	8	16	32	64	128	256	UNIT
Input Span	± 2.5	± 0.625	± 0.312	± 0.156	$\pm 78m$	$\pm 39m$	$\pm 19.5m$	$\pm 9.76m$	V
LSB	38.1	9.54	4.77	2.38	1.19	0.596	0.298	0.149	μV
Noise Free Resolution*	65536	65536	65536	65536	65536	65536	32768	16384	Counts
Gain Error	5	5	5	5	5	5	5	8	ppm of FS
Offset Error	0.5	0.5	0.5	0.5	0.5	0.5	0.5	0.5	μV

Table 2b. The LTC2480 Performance vs GAIN in 2x Speed Mode ($V_{CC} = 5V$, $V_{REF} = 5V$)

GAIN	1	2	4	8	16	32	64	128	UNIT
Input Span	± 2.5	± 1.25	± 0.625	± 0.312	± 0.156	$\pm 78m$	$\pm 39m$	$\pm 19.5m$	V
LSB	38.1	19.1	9.54	4.77	2.38	1.19	0.596	0.298	μV
Noise Free Resolution*	65536	65536	65536	65536	65536	65536	45875	22937	Counts
Gain Error	5	5	5	5	5	5	5	5	ppm of FS
Offset Error	200	200	200	200	200	200	200	200	μV

*The resolution in counts is calculated as the FS divided by LSB or the RMS noise value, whichever is larger.

GAIN (GS2, GS1, GS0)

The input referred gain of the LTC2480 is adjustable from 1 to 256. With a gain of 1, the differential input range is $\pm V_{REF}/2$ and the common mode input range is rail-to-rail. As the GAIN is increased, the differential input range is reduced to $\pm V_{REF}/2 \cdot GAIN$ but the common mode input range remains rail-to-rail. As the differential gain is increased, low level voltages are digitized with greater resolution. At a gain of 256, the LTC2480 digitizes an input signal range of $\pm 9.76mV$ with over 16,000 counts.

Temperature Sensor (IM)

The LTC2480 includes an on-chip temperature sensor. The temperature sensor is selected by setting IM = 1 in the serial input data stream. Conversions are performed directly on the temperature sensor by the converter. While operating in this mode, the device behaves as a temperature to bits converter. The digital reading is proportional to the absolute temperature of the device. This feature allows the converter to linearize temperature sensors or continuously remove temperature effects from external sensors. Several applications leveraging this feature are presented in more detail in the applications section. While operating in this mode, the gain is set to 1 and the speed is set to normal independent of the control bits (GS2, GS1, GS0 and SPD).

Rejection Mode (FA, FB)

The LTC2480 includes a high accuracy on-chip oscillator with no required external components. Coupled with a 4th order digital lowpass filter, the LTC2480 rejects line frequency noise. In the default mode, the LTC2480 simultaneously rejects 50Hz and 60Hz by at least 87dB. The LTC2480 can also be configured to selectively reject 50Hz or 60Hz to better than 110dB.

Speed Mode (SPD)

The LTC2480 continuously performs offset calibrations. Every conversion cycle, two conversions are automatically performed (default) and the results combined. This result is free from offset and drift. In applications where the offset is not critical, the autocalibration feature can be disabled with the benefit of twice the output rate.

Linearity, full-scale accuracy and full-scale drift are identical for both 2x and 1x speed modes. In both the 1x and 2x speed there is no latency. This enables input steps or multiplexer channel changes to settle in a single conversion cycle easing system overhead and increasing the effective conversion rate.

APPLICATIONS INFORMATION

Output Data Format

The LTC2480 serial output data stream is 24 bits long. The first 3 bits represent status information indicating the sign and conversion state. The next 17 bits are the conversion result, MSB first. The remaining 4 bits indicate the configuration state associated with the current conversion result. The third and fourth bit together are also used to indicate an underrange condition (the differential input voltage is below $-FS$) or an overrange condition (the differential input voltage is above $+FS$).

In applications where the processor generates 32 clock cycles, or to remain compatible with higher resolution converters, the LTC2480's digital interface will ignore extra clock edges seen during the next conversion period after the 24th and output "1" for the extra clock cycles. Furthermore, \overline{CS} may be pulled high prior to outputting all 24 bits, aborting the data out transfer and initiating a new conversion.

Bit 23 (first output bit) is the end of conversion (\overline{EOC}) indicator. This bit is available at the SDO pin during the conversion and sleep states whenever the \overline{CS} pin is LOW. This bit is HIGH during the conversion and goes LOW when the conversion is complete.

Bit 22 (second output bit) is a dummy bit (DMY) and is always LOW.

Bit 21 (third output bit) is the conversion result sign indicator (SIG). If V_{IN} is >0 , this bit is HIGH. If V_{IN} is <0 , this bit is LOW.

Bit 20 (fourth output bit) is the most significant bit (MSB) of the result. This bit in conjunction with Bit 21 also provides the underrange or overrange indication. If both Bit 21 and Bit 20 are HIGH, the differential input voltage is above $+FS$. If both Bit 21 and Bit 20 are LOW, the differential input voltage is below $-FS$.

The function of these bits is summarized in Table 3.

Table 3. LTC2480 Status Bits

INPUT RANGE	BIT 23 EOC	BIT 22 DMY	BIT 21 SIG	BIT 20 MSB
$V_{IN} \geq 0.5 \cdot V_{REF}$	0	0	1	1
$0V \leq V_{IN} < 0.5 \cdot V_{REF}$	0	0	1	0
$-0.5 \cdot V_{REF} \leq V_{IN} < 0V$	0	0	0	1
$V_{IN} < -0.5 \cdot V_{REF}$	0	0	0	0

Bits 20-4 are the 16-bit plus sign conversion result MSB first.

Bits 3-0 are the corresponding configuration bits for the present conversion result. Bits 3-1 are the gain set bits and bit 0 is IM (see Figure 2).

Data is shifted out of the SDO pin under control of the serial clock (SCK) (see Figure 2). Whenever \overline{CS} is HIGH, SDO remains high impedance and any externally generated SCK clock pulses are ignored by the internal data out shift register.

In order to shift the conversion result out of the device, \overline{CS} must first be driven LOW. \overline{EOC} is seen at the SDO pin of the device once \overline{CS} is pulled LOW. \overline{EOC} changes in real time

Table 4. LTC2480 Output Data Format

DIFFERENTIAL INPUT VOLTAGE V_{IN}^*	BIT 23 EOC	BIT 22 DMY	BIT 21 SIG	BIT 20 MSB	BIT 19	BIT 18	BIT 17	...	BIT 4
$V_{IN}^* \geq FS^{**}$	0	0	1	1	0	0	0	...	0
$FS^{**} - 1LSB$	0	0	1	0	1	1	1	...	1
$0.5 \cdot FS^{**}$	0	0	1	0	1	0	0	...	0
$0.5 \cdot FS^{**} - 1LSB$	0	0	1	0	0	1	1	...	1
0	0	0	1	0	0	0	0	...	0
-1LSB	0	0	0	1	1	1	1	...	1
$-0.5 \cdot FS^{**}$	0	0	0	1	1	0	0	...	0
$-0.5 \cdot FS^{**} - 1LSB$	0	0	0	1	0	1	1	...	1
$-FS^{**}$	0	0	0	1	0	0	0	...	0
$V_{IN}^* < -FS^{**}$	0	0	0	0	1	1	1	...	1

*The differential input voltage $V_{IN} = IN^+ - IN^-$. **The full-scale voltage $FS = 0.5 \cdot V_{REF}/GAIN$.

APPLICATIONS INFORMATION

from HIGH to LOW at the completion of a conversion. This signal may be used as an interrupt for an external microcontroller. Bit 23 (\overline{EOC}) can be captured on the first rising edge of SCK. Bit 22 is shifted out of the device on the first falling edge of SCK. The final data bit (Bit 0) is shifted out on the falling edge of the 23rd SCK and may be latched on the rising edge of the 24th SCK pulse. On the falling edge of the 24th SCK pulse, SDO goes HIGH indicating the initiation of a new conversion cycle. This bit serves as \overline{EOC} (Bit 23) for the next conversion cycle. Table 4 summarizes the output data format.

As long as the voltage on the IN^+ and IN^- pins is maintained within the $-0.3V$ to $(V_{CC} + 0.3V)$ absolute maximum operating range, a conversion result is generated for any differential input voltage V_{IN} from $-FS = -0.5 \cdot V_{REF}/GAIN$ to $+FS = 0.5 \cdot V_{REF}/GAIN$. For differential input voltages greater than $+FS$, the conversion result is clamped to the value corresponding to the $+FS + 1LSB$. For differential input voltages below $-FS$, the conversion result is clamped to the value corresponding to $-FS - 1LSB$.

Conversion Clock

A major advantage the delta-sigma converter offers over conventional type converters is an on-chip digital filter (commonly implemented as a SINC or Comb filter). For high resolution, low frequency applications, this filter is typically designed to reject line frequencies of 50Hz or 60Hz plus their harmonics. The filter rejection performance is directly related to the accuracy of the converter system clock. The LTC2480 incorporates a highly accurate on-chip oscillator. This eliminates the need for external frequency setting components such as crystals or oscillators.

Frequency Rejection Selection (F_0)

The LTC2480 internal oscillator provides better than 110dB normal mode rejection at the line frequency and all its harmonics (up to the 255th) for 50Hz $\pm 2\%$ or 60Hz $\pm 2\%$, or better than 87dB normal mode rejection from 48Hz to 62.4Hz. The rejection mode is selected by writing to the on-chip configuration register and the default mode at POR is simultaneous 50Hz/60Hz rejection.

When a fundamental rejection frequency different from 50Hz or 60Hz is required or when the converter must be

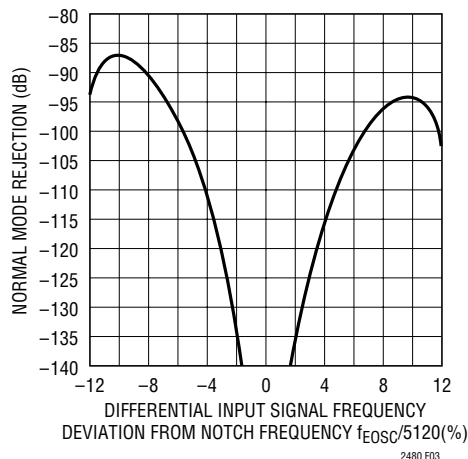

Figure 3. LTC2480 Normal Mode Rejection When Using an External Oscillator

synchronized with an outside source, the LTC2480 can operate with an external conversion clock. The converter automatically detects the presence of an external clock signal at the F_0 pin and turns off the internal oscillator. The frequency f_{EOSC} of the external signal must be at least 10kHz to be detected. The external clock signal duty cycle is not significant as long as the minimum and maximum specifications for the high and low periods t_{HEO} and t_{LEO} are observed.

While operating with an external conversion clock of a frequency f_{EOSC} , the LTC2480 provides better than 110dB normal mode rejection in a frequency range of $f_{EOSC}/5120 \pm 4\%$ and its harmonics. The normal mode rejection as a function of the input frequency deviation from $f_{EOSC}/5120$ is shown in Figure 3.

Whenever an external clock is not present at the F_0 pin, the converter automatically activates its internal oscillator and enters the Internal Conversion Clock mode. The LTC2480 operation will not be disturbed if the change of conversion clock source occurs during the sleep state or during the data output state while the converter uses an external serial clock. If the change occurs during the conversion state, the result of the conversion in progress may be outside specifications but the following conversions will not be affected. If the change occurs during the data output state and the converter is in the Internal SCK mode, the serial clock duty cycle may be affected but the serial data stream will remain valid.

APPLICATIONS INFORMATION

Table 5. LTC2480 State Duration

STATE	OPERATING MODE		DURATION
CONVERT	Internal Oscillator	60Hz Rejection	133ms, Output Data Rate ≤ 7.5 Readings/s for 1x Speed Mode 67ms, Output Data Rate ≤ 15 Readings/s for 2x Speed Mode
		50Hz Rejection	160ms, Output Data Rate ≤ 6.2 Readings/s for 1x Speed Mode 80ms, Output Data Rate ≤ 12.5 Readings/s for 2x Speed Mode
		50Hz/60Hz Rejection	147ms, Output Data Rate ≤ 6.8 Readings/s for 1x Speed Mode 73.6ms, Output Data Rate ≤ 13.6 Readings/s for 2x Speed Mode
	External Oscillator	F_0 = External Oscillator with Frequency f_{EOSC} kHz ($f_{EOSC}/5120$ Rejection)	$41036/f_{EOSC}$ s, Output Data Rate $\leq f_{EOSC}/41036$ Readings/s for 1x Speed Mode $20556/f_{EOSC}$ s, Output Data Rate $\leq f_{EOSC}/20556$ Readings/s for 2x Speed Mode
SLEEP			As Long As \overline{CS} = HIGH, After a Conversion is Complete
DATA OUTPUT	Internal Serial Clock	F_0 = LOW/HIGH (Internal Oscillator)	As Long As \overline{CS} = LOW But Not Longer Than 0.62ms (24 SCK Cycles)
		F_0 = External Oscillator with Frequency f_{EOSC} kHz	As Long As \overline{CS} = LOW But Not Longer Than $192/f_{EOSC}$ ms (24 SCK Cycles)
	External Serial Clock with Frequency f_{SCK} kHz		As Long As \overline{CS} = LOW But Not Longer Than $24/f_{SCK}$ ms (24 SCK Cycles)

Table 5 summarizes the duration of each state and the achievable output data rate as a function of F_0 .

Ease of Use

The LTC2480 data output has no latency, filter settling delay or redundant data associated with the conversion cycle. There is a one-to-one correspondence between the conversion and the output data. Therefore, multiplexing multiple analog voltages is easy.

The LTC2480 performs offset and full-scale calibrations every conversion cycle. This calibration is transparent to the user and has no effect on the cyclic operation described above. The advantage of continuous calibration is extreme stability of offset and full-scale readings with respect to time, supply voltage change and temperature drift.

Power-Up Sequence

The LTC2480 automatically enters an internal reset state when the power supply voltage V_{CC} drops below approximately 2V. This feature guarantees the integrity of the conversion result and of the serial interface mode selection.

When the V_{CC} voltage rises above this critical threshold, the converter creates an internal power-on-reset (POR)

signal with a duration of approximately 4ms. The POR signal clears all internal registers. Following the POR signal, the LTC2480 starts a normal conversion cycle and follows the succession of states described in Figure 1. The first conversion result following POR is accurate within the specifications of the device if the power supply voltage is restored within the operating range (2.7V to 5.5V) before the end of the POR time interval.

On-Chip Temperature Sensor

The LTC2480 contains an on-chip PTAT (proportional to absolute temperature) signal that can be used as a temperature sensor. The internal PTAT has a typical value of 420mV at 27°C and is proportional to the absolute temperature value with a temperature coefficient of $420/(27 + 273) = 1.40\text{mV}/^\circ\text{C}$ (SLOPE), as shown in Figure 4. The internal PTAT signal is used in a single-ended mode referenced to device ground internally. The GAIN is automatically set to one (independent of the values of GS0, GS1, GS2) in order to preserve the PTAT property at the ADC output code and avoid an out of range error. The 1x speed mode with automatic offset calibration is automatically selected for the internal PTAT signal measurement as well.

APPLICATIONS INFORMATION

When using the internal temperature sensor, if the output code is normalized to $R_{SDO} = V_{PTAT}/V_{REF}$, the temperature is calculated using the following formula:

$$T_K = \frac{R_{SDO} \cdot V_{REF}}{SLOPE} \text{ in Kelvin}$$

and

$$T_C = \frac{R_{SDO} \cdot V_{REF}}{SLOPE} - 273 \text{ in } ^\circ\text{C}$$

where SLOPE is nominally 1.4mV/°C.

Since the PTAT signal can have an initial value variation which results in errors in SLOPE, to achieve better temperature measurements, a one-time calibration is needed to adjust the SLOPE value. The converter output of the PTAT signal, R_{0SDO} , is measured at a known temperature T_0 (in °C) and the SLOPE is calculated as:

$$SLOPE = \frac{R_{0SDO} \cdot V_{REF}}{T_0 + 273}$$

This calibrated SLOPE can be used to calculate the temperature.

If the same V_{REF} source is used during calibration and temperature measurement, the actual value of the V_{REF} is not needed to measure the temperature as shown in the calculation below:

$$\begin{aligned} T_C &= \frac{R_{SDO} \cdot V_{REF}}{SLOPE} - 273 \\ &= \frac{R_{SDO}}{R_{0SDO}} \cdot (T_0 + 273) - 273 \end{aligned}$$

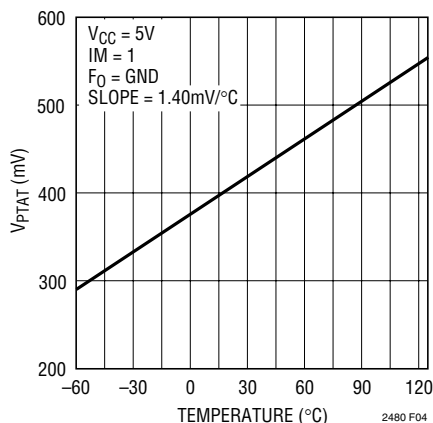

Figure 4. Internal PTAT Signal vs Temperature

Reference Voltage Range

The LTC2480 external reference voltage range is 0.1V to V_{CC} . The converter output noise is determined by the thermal noise of the front-end circuits, and as such, its value in nanovolts is nearly constant with reference voltage. Since the transition noise (600nV) is much less than the quantization noise ($V_{REF}/2^{17}$), a decrease in the reference voltage will increase the converter resolution. A reduced reference voltage will also improve the converter performance when operated with an external conversion clock (external F_0 signal) at substantially higher output data rates (see the Output Data Rate section). V_{REF} must be $\geq 1.1V$ to use the internal temperature sensor.

The negative reference input to the converter is internally tied to GND. GND (Pin 8) should be connected to a ground plane through as short a trace as possible to minimize voltage drop. The LTC2480 has an average operational current of 160 μ A and for 0.1 Ω parasitic resistance, the voltage drop of 16 μ V causes a gain error of 3.2ppm for $V_{REF} = 5V$.

Input Voltage Range

The analog input is truly differential with an absolute/common mode range for the IN^+ and IN^- input pins extending from $GND - 0.3V$ to $V_{CC} + 0.3V$. Outside these limits, the ESD protection devices begin to turn on and the errors due to input leakage current increase rapidly. Within these limits, the LTC2480 converts the bipolar differential input signal, $V_{IN} = IN^+ - IN^-$, from $-FS$ to $+FS$ where $FS = 0.5 \cdot V_{REF}/GAIN$. Outside this range, the converter indicates the overrange or the underrange condition using distinct output codes. Since the differential input current cancellation does not rely on an on-chip buffer, current cancellation as well as DC performance is maintained rail-to-rail.

Input signals applied to IN^+ and IN^- pins may extend by 300mV below ground and above V_{CC} . In order to limit any fault current, resistors of up to 5k may be added in series with the IN^+ and IN^- pins without affecting the performance of the devices. The effect of the series resistance on the converter accuracy can be evaluated from the curves presented in the Input Current/Reference Current sections. In addition, series resistors will introduce a

APPLICATIONS INFORMATION

temperature dependent offset error due to the input leakage current. A 1nA input leakage current will develop a 1ppm offset error on a 5k resistor if $V_{REF} = 5V$. This error has a very strong temperature dependency.

SERIAL INTERFACE TIMING MODES

The LTC2480's 4-wire interface is SPI and MICROWIRE compatible. This interface offers several flexible modes of operation. These include internal/external serial clock, 3- or 4-wire I/O, single cycle or continuous conversion. The following sections describe each of these serial interface timing modes in detail. In all these cases, the converter can use the internal oscillator ($F_0 = LOW$ or $F_0 = HIGH$) or an external oscillator connected to the F_0 pin. Refer to Table 6 for a summary.

External Serial Clock, Single Cycle Operation (SPI/MICROWIRE Compatible)

This timing mode uses an external serial clock to shift out the conversion result and a \overline{CS} signal to monitor and control the state of the conversion cycle, see Figure 5.

The serial clock mode is selected on the falling edge of \overline{CS} . To select the external serial clock mode, the serial clock pin (SCK) must be LOW during each \overline{CS} falling edge.

The serial data output pin (SDO) is Hi-Z as long as \overline{CS} is HIGH. At any time during the conversion cycle, \overline{CS} may be pulled LOW in order to monitor the state of the converter. While \overline{CS} is pulled LOW, EOC is output to the SDO pin. $EOC = 1$ while a conversion is in progress and $EOC = 0$ if the device is in the sleep state. Independent of \overline{CS} , the device automatically enters the low power sleep state once the conversion is complete.

When the device is in the sleep state, its conversion result is held in an internal static shift register. The device remains in the sleep state until the first rising edge of SCK is seen while \overline{CS} is LOW. The input data is then shifted in via the SDI pin on the rising edge of SCK (including the first rising edge) and the output data is shifted out of the SDO pin on each falling edge of SCK. This enables external circuitry to latch the output on the rising edge of SCK. EOC can be latched on the first rising edge of SCK and the last bit of the conversion result can be latched on the 24th rising edge of SCK. On the 24th falling edge of SCK, the device begins a new conversion. SDO goes HIGH ($EOC = 1$) indicating a conversion is in progress. In applications where the processor generates 32 clock cycles, or to remain compatible with higher resolution converters, the LTC2480's digital interface will ignore extra clock edges seen during the next conversion period after the 24th and outputs "1" for the extra clock cycles.

At the conclusion of the data cycle, \overline{CS} may remain LOW and EOC monitored as an end-of-conversion interrupt. Alternatively, \overline{CS} may be driven HIGH setting SDO to Hi-Z. As described above, \overline{CS} may be pulled LOW at any time in order to monitor the conversion status.

Typically, \overline{CS} remains LOW during the data output state. However, the data output state may be aborted by pulling \overline{CS} HIGH anytime between the first rising edge and the 24th falling edge of SCK (see Figure 6). On the rising edge of \overline{CS} , the device aborts the data output state and immediately initiates a new conversion. If the device has not finished loading the last input bit SPD of SDI by the time \overline{CS} is pulled HIGH, the SDI information is discarded and the previous configuration is kept. This is useful for systems not requiring all 24 bits of output data, aborting an invalid conversion cycle or synchronizing the start of a conversion.

Table 6. LTC2480 Interface Timing Modes

CONFIGURATION	SCK SOURCE	CONVERSION CYCLE CONTROL	DATA OUTPUT CONTROL	CONNECTION and WAVEFORMS
External SCK, Single Cycle Conversion	External	\overline{CS} and SCK	\overline{CS} and SCK	Figures 5, 6
External SCK, 3-Wire I/O	External	SCK	SCK	Figure 7
Internal SCK, Single Cycle Conversion	Internal	$\overline{CS}\downarrow$	$\overline{CS}\downarrow$	Figures 8, 9
Internal SCK, 3-Wire I/O, Continuous Conversion	Internal	Continuous	Internal	Figure 10

APPLICATIONS INFORMATION

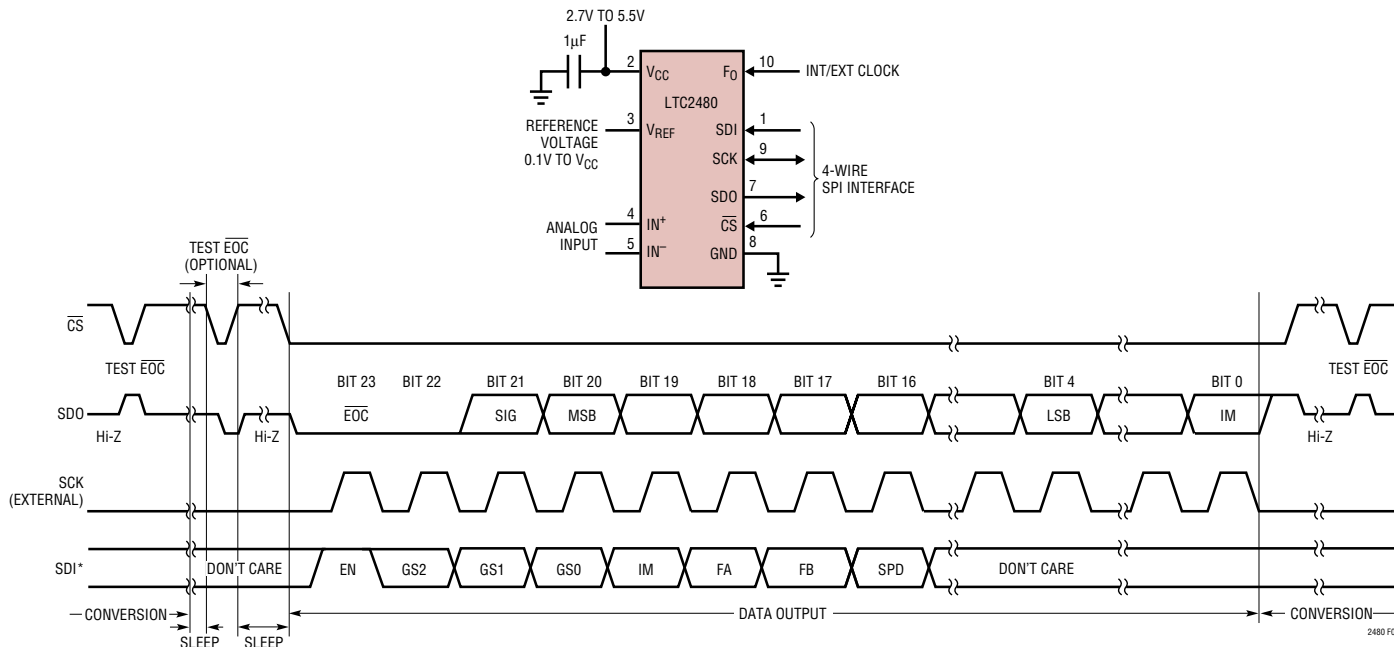

Figure 5. External Serial Clock, Single Cycle Operation

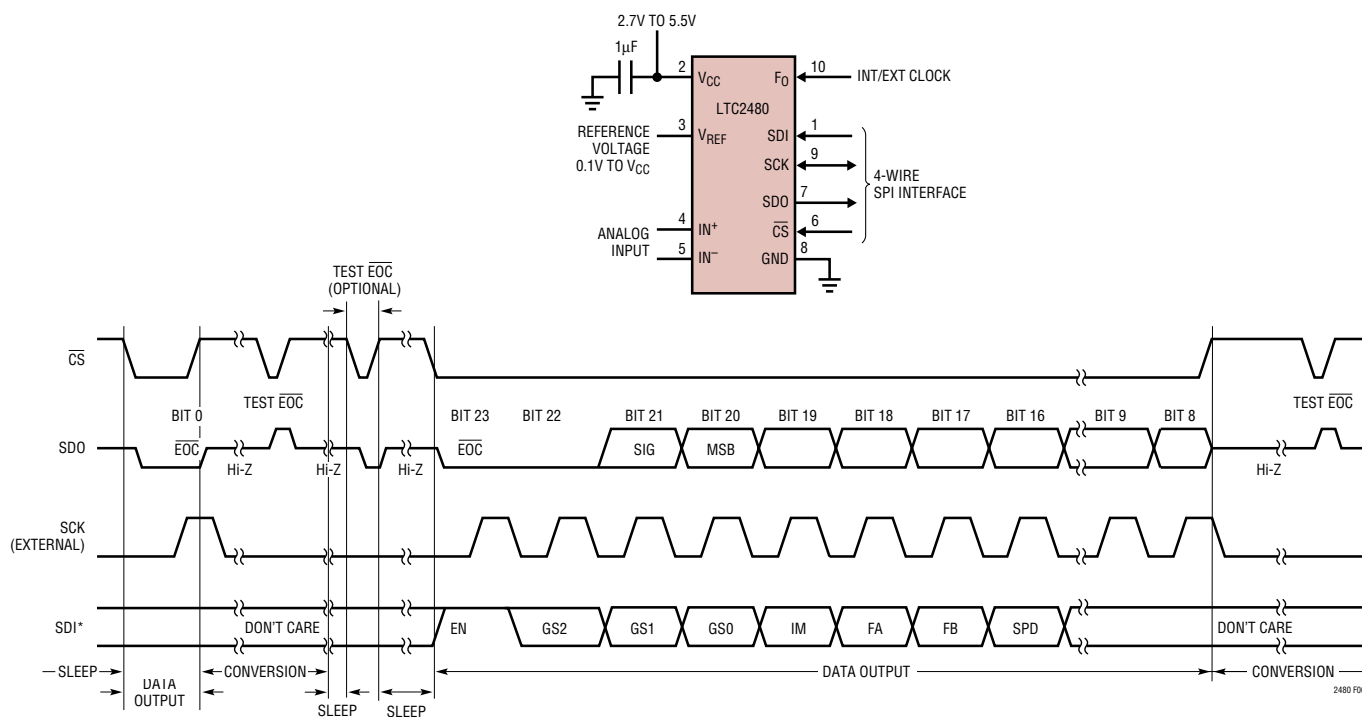

Figure 6. External Serial Clock, Reduced Data Output Length

APPLICATIONS INFORMATION

External Serial Clock, 3-Wire I/O

This timing mode utilizes a 3-wire serial I/O interface. The conversion result is shifted out of the device by an externally generated serial clock (SCK) signal, see Figure 7. \overline{CS} may be permanently tied to ground, simplifying the user interface or transmission over an isolation barrier.

The external serial clock mode is selected at the end of the power-on reset (POR) cycle. The POR cycle is concluded typically 4ms after V_{CC} exceeds approximately 2V. The level applied to SCK at this time determines if SCK is internal or external. SCK must be driven LOW prior to the end of POR in order to enter the external serial clock timing mode.

Since \overline{CS} is tied LOW, the end-of-conversion (\overline{EOC}) can be continuously monitored at the SDO pin during the convert and sleep states. \overline{EOC} may be used as an interrupt to an external controller indicating the conversion result is ready. $\overline{EOC} = 1$ while the conversion is in progress and $\overline{EOC} = 0$ once the conversion ends. On the falling edge of \overline{EOC} , the conversion result is loaded into an internal static shift register. The input data is then shifted in via the SDI pin on the rising edge of SCK (including the first rising edge) and the output data is shifted out of the SDO pin on each falling edge of SCK. \overline{EOC} can be latched on the first rising edge of SCK. On the 24th falling edge of SCK, SDO goes HIGH ($\overline{EOC} = 1$) indicating a new conversion has

begun. In applications where the processor generates 32 clock cycles, or to remain compatible with higher resolution converters, the LTC2480's digital interface will ignore extra clock edges seen during the next conversion period after the 24th and outputs "1" for the extra clock cycles.

Internal Serial Clock, Single Cycle Operation

This timing mode uses an internal serial clock to shift out the conversion result and a \overline{CS} signal to monitor and control the state of the conversion cycle, see Figure 8.

In order to select the internal serial clock timing mode, the serial clock pin (SCK) must be floating (Hi-Z) or pulled HIGH prior to the falling edge of \overline{CS} . The device will not enter the internal serial clock mode if SCK is driven LOW on the falling edge of \overline{CS} . An internal weak pull-up resistor is active on the SCK pin during the falling edge of \overline{CS} ; therefore, the internal serial clock timing mode is automatically selected if SCK is not externally driven.

The serial data output pin (SDO) is Hi-Z as long as \overline{CS} is HIGH. At any time during the conversion cycle, \overline{CS} may be pulled LOW in order to monitor the state of the converter. Once \overline{CS} is pulled LOW, SCK goes LOW and \overline{EOC} is output to the SDO pin. $\overline{EOC} = 1$ while a conversion is in progress and $\overline{EOC} = 0$ if the device is in the sleep state.

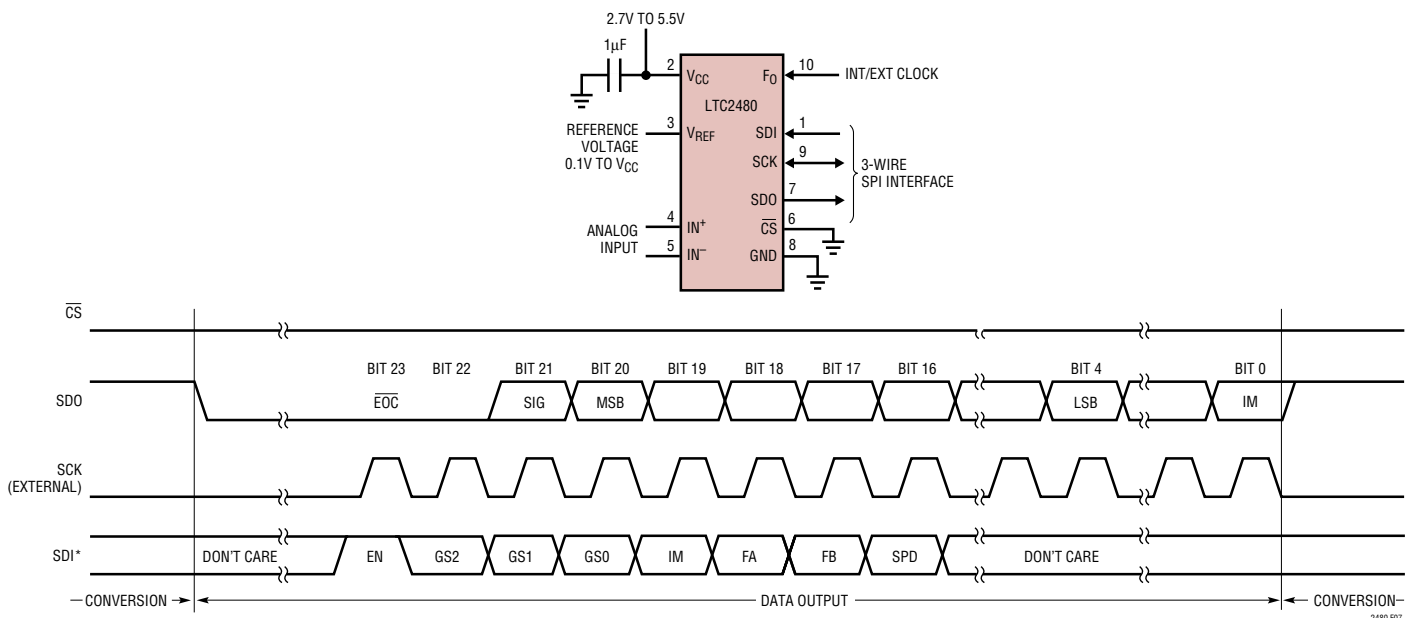

Figure 7. External Serial Clock, $\overline{CS} = 0$ Operation

APPLICATIONS INFORMATION

When testing \overline{EOC} , if the conversion is complete ($\overline{EOC} = 0$), the device will exit the low power mode during the \overline{EOC} test. In order to allow the device to return to the low power sleep state, \overline{CS} must be pulled HIGH before the first rising edge of SCK. In the internal SCK timing mode, SCK goes HIGH and the device begins outputting data at time $t_{EOCtest}$ after the falling edge of \overline{CS} (if $\overline{EOC} = 0$) or $t_{EOCtest}$ after \overline{EOC} goes LOW (if \overline{CS} is LOW during the falling edge of \overline{EOC}). The value of $t_{EOCtest}$ is 12 μ s if the device is using its internal oscillator. If F_0 is driven by an external oscillator of frequency f_{EOSC} , then $t_{EOCtest}$ is $3.6/f_{EOSC}$ in seconds. If \overline{CS} is pulled HIGH before time $t_{EOCtest}$, the device returns to the sleep state and the conversion result is held in the internal static shift register.

If \overline{CS} remains LOW longer than $t_{EOCtest}$, the first rising edge of SCK will occur and the conversion result is serially shifted out of the SDO pin. The data I/O cycle concludes after the 24th rising edge. The input data is shifted in via the SDI pin on the rising edge of SCK (including the first rising edge) and the output data is shifted out of the SDO pin on each falling edge of SCK. The internally generated serial clock is output to the SCK pin. This signal may be

used to shift the conversion result into external circuitry. \overline{EOC} can be latched on the first rising edge of SCK and the last bit of the conversion result on the 24th rising edge of SCK. After the 24th rising edge, SDO goes HIGH ($\overline{EOC} = 1$), SCK stays HIGH and a new conversion starts.

\overline{CS} remains LOW during the data output state. However, the data output state may be aborted by pulling \overline{CS} HIGH anytime between the first and 24th rising edge of SCK (see Figure 9). On the rising edge of \overline{CS} , the device aborts the data output state and immediately initiates a new conversion. If the device has not finished loading the last input bit SPD of SDI by the time \overline{CS} is pulled HIGH, the SDI information is discarded and the previous configuration is still kept. This is useful for systems not requiring all 24 bits of output data, aborting an invalid conversion cycle, or synchronizing the start of a conversion. If \overline{CS} is pulled HIGH while the converter is driving SCK LOW, the internal pull-up is not available to restore SCK to a logic HIGH state. This will cause the device to exit the internal serial clock mode on the next falling edge of \overline{CS} . This can be avoided by adding an external 10k pull-up resistor to the SCK pin or by never pulling \overline{CS} HIGH when SCK is LOW.

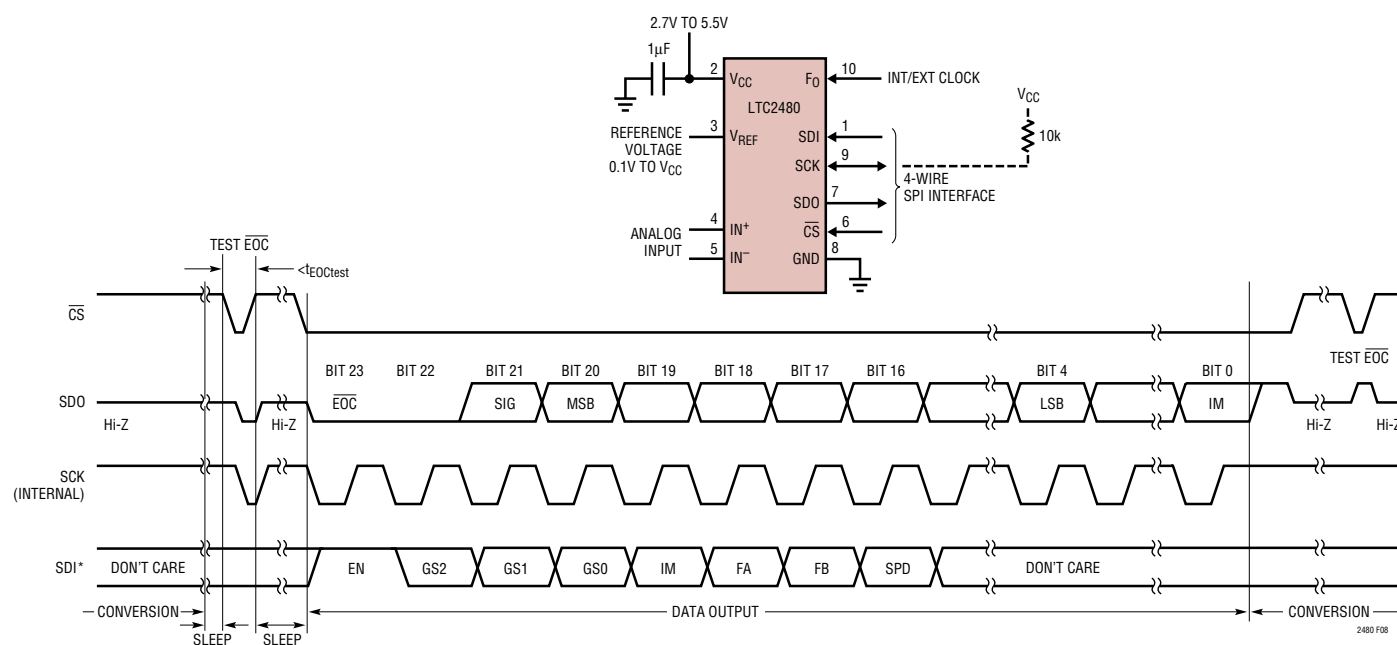

Figure 8. Internal Serial Clock, Single Cycle Operation

APPLICATIONS INFORMATION

Whenever SCK is LOW, the LTC2480's internal pull-up at pin SCK is disabled. Normally, SCK is not externally driven if the device is in the internal SCK timing mode. However, certain applications may require an external driver on SCK. If this driver goes Hi-Z after outputting a LOW signal, the LTC2480's internal pull-up remains disabled. Hence, SCK remains LOW. On the next falling edge of \overline{CS} , the device is switched to the external SCK timing mode. By adding an external 10k pull-up resistor to SCK, this pin goes HIGH once the external driver goes Hi-Z. On the next \overline{CS} falling edge, the device will remain in the internal SCK timing mode.

A similar situation may occur during the sleep state when \overline{CS} is pulsed HIGH-LOW-HIGH in order to test the conversion status. If the device is in the sleep state ($\overline{EOC} = 0$), SCK will go LOW. Once \overline{CS} goes HIGH (within the time period defined above as $t_{EOCtest}$), the internal pull-up is activated. For a heavy capacitive load on the SCK pin, the internal pull-up may not be adequate to return SCK to a HIGH level before \overline{CS} goes low again. This is not a concern under normal conditions where \overline{CS} remains LOW after detecting $\overline{EOC} = 0$. This situation is easily overcome by adding an external 10k pull-up resistor to the SCK pin.

Internal Serial Clock, 3-Wire I/O, Continuous Conversion

This timing mode uses a 3-wire interface. The conversion result is shifted out of the device by an internally generated serial clock (SCK) signal, see Figure 10. \overline{CS} may be permanently tied to ground, simplifying the user interface or transmission over an isolation barrier.

The internal serial clock mode is selected at the end of the power-on reset (POR) cycle. The POR cycle is concluded approximately 1ms after V_{CC} exceeds 2V. An internal weak pull-up is active during the POR cycle; therefore, the internal serial clock timing mode is automatically selected if SCK is not externally driven LOW (if SCK is loaded such that the internal pull-up cannot pull the pin HIGH, the external SCK mode will be selected).

During the conversion, the SCK and the serial data output pin (SDO) are HIGH ($\overline{EOC} = 1$). Once the conversion is complete, SCK and SDO go LOW ($\overline{EOC} = 0$) indicating the conversion has finished and the device has entered the low power sleep state. The part remains in the sleep state a minimum amount of time (1/2 the internal SCK period)

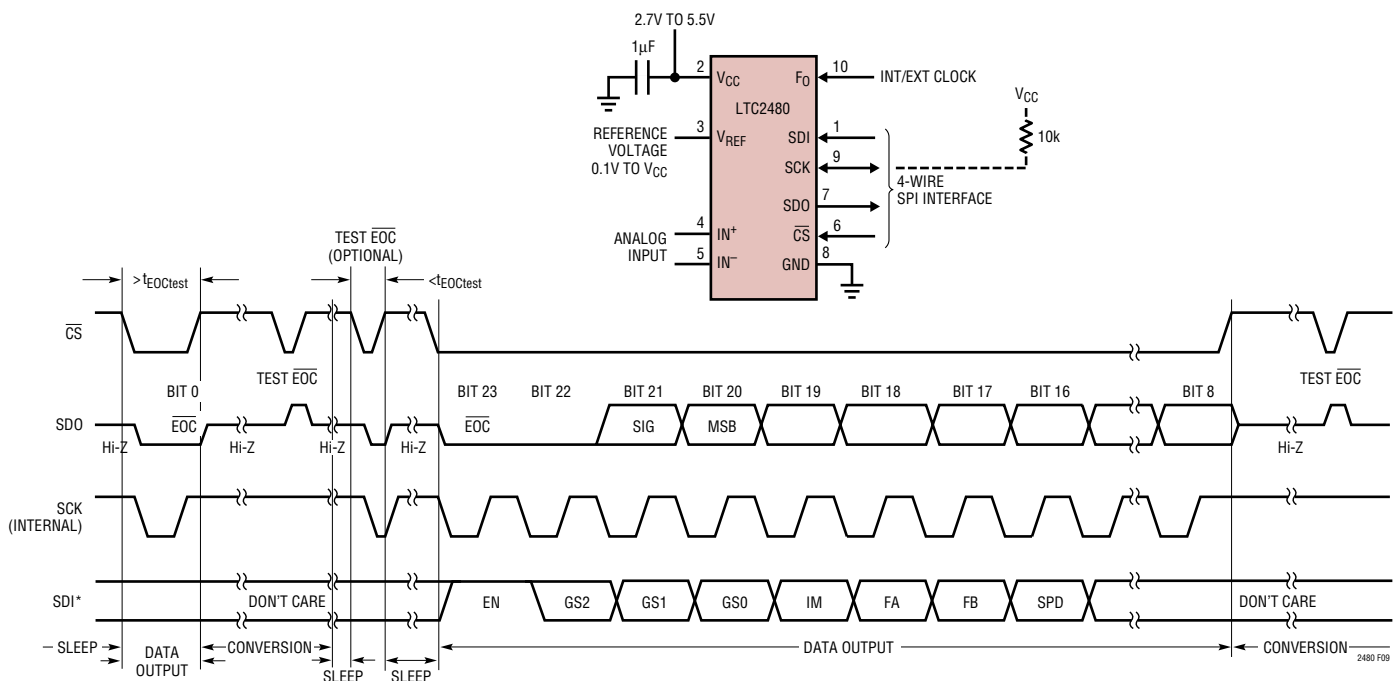

Figure 9. Internal Serial Clock, Reduce Data Output Length

APPLICATIONS INFORMATION

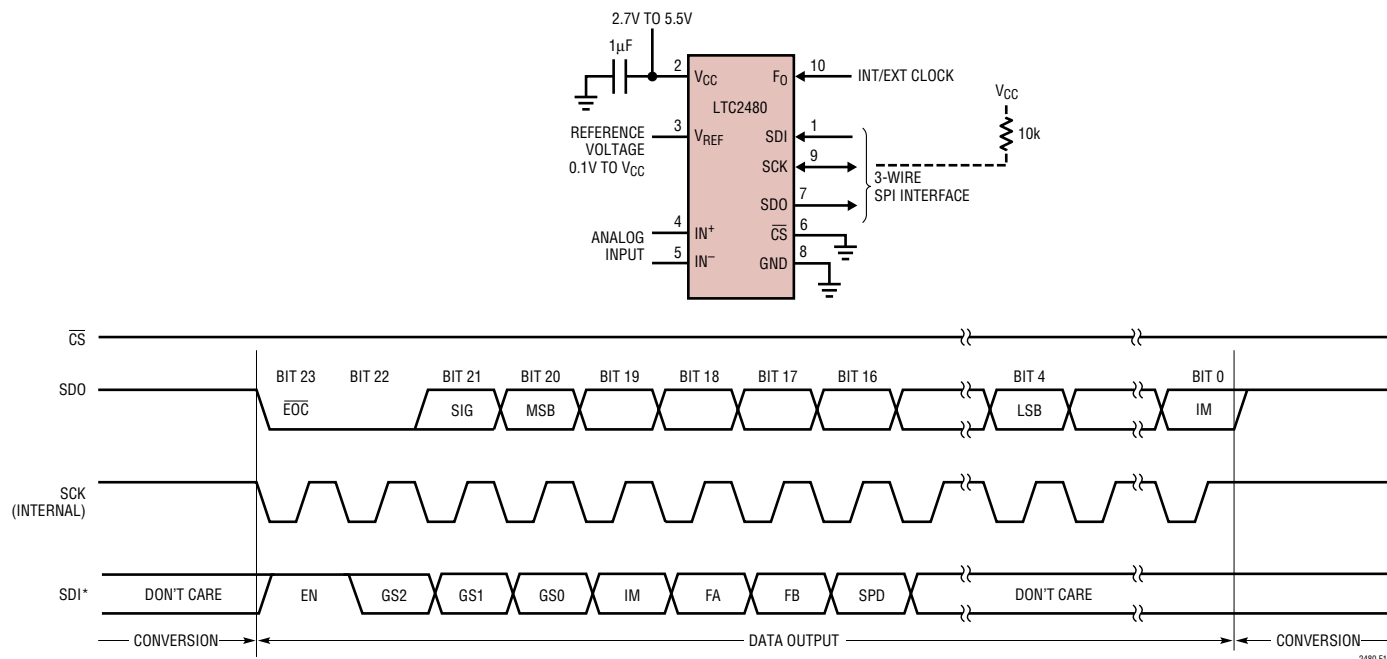

Figure 10. Internal Serial Clock, $\overline{CS} = 0$ Continuous Operation

then immediately begins outputting data. The data input/output cycle begins on the first rising edge of SCK and ends after the 24th rising edge. The input data is then shifted in via the SDI pin on the rising edge of SCK (including the first rising edge) and the output data is shifted out of the SDO pin on each falling edge of SCK. The internally generated serial clock is output to the SCK pin. This signal may be used to shift the conversion result into external circuitry. EOC can be latched on the first rising edge of SCK and the last bit of the conversion result can be latched on the 24th rising edge of SCK. After the 24th rising edge, SDO goes HIGH ($\overline{EOC} = 1$) indicating a new conversion is in progress. SCK remains HIGH during the conversion.

PRESERVING THE CONVERTER ACCURACY

The LTC2480 is designed to reduce as much as possible the conversion result sensitivity to device decoupling, PCB layout, antialiasing circuits, line frequency perturbations and so on. Nevertheless, in order to preserve the 24-bit accuracy capability of this part, some simple precautions are required.

Digital Signal Levels

The LTC2480's digital interface is easy to use. Its digital inputs (SDI, F_0 , \overline{CS} and SCK in External SCK mode of operation) accept standard CMOS logic levels and the internal hysteresis receivers can tolerate edge transition times as slow as 100µs. However, some considerations are required to take advantage of the exceptional accuracy and low supply current of this converter.

The digital output signals (SDO and SCK in Internal SCK mode of operation) are less of a concern because they are not generally active during the conversion state.

While a digital input signal is in the range 0.5V to ($V_{CC} - 0.5V$), the CMOS input receiver draws additional current from the power supply. It should be noted that, when any one of the digital input signals (SDI, F_0 , \overline{CS} and SCK in External SCK mode of operation) is within this range, the power supply current may increase even if the signal in question is at a valid logic level. For micropower operation, it is recommended to drive all digital input signals to full CMOS levels [$V_{IL} < 0.4V$ and $V_{OH} > (V_{CC} - 0.4V)$].

APPLICATIONS INFORMATION

During the conversion period, the undershoot and/or overshoot of a fast digital signal connected to the pins can severely disturb the analog to digital conversion process. Undershoot and overshoot occur because of the impedance mismatch of the circuit board trace at the converter pin when the transition time of an external control signal is less than twice the propagation delay from the driver to the LTC2480. For reference, on a regular FR-4 board, signal propagation velocity is approximately 183ps/inch for internal traces and 170ps/inch for surface traces. Thus, a driver generating a control signal with a minimum transition time of 1ns must be connected to the converter pin through a trace shorter than 2.5 inches. This problem becomes particularly difficult when shared control lines are used and multiple reflections may occur. The solution is to carefully terminate all transmission lines close to their characteristic impedance.

Parallel termination near the LTC2480 pin will eliminate this problem but will increase the driver power dissipation. A series resistor between 27 Ω and 56 Ω placed near the driver output pin will also eliminate this problem without additional power dissipation. The actual resistor value depends upon the trace impedance and connection topology.

An alternate solution is to reduce the edge rate of the control signals. It should be noted that using very slow edges will increase the converter power supply current during the transition time. The differential input architecture reduces the converter's sensitivity to ground currents.

Particular attention must be given to the connection of the F_0 signal when the LTC2480 is used with an external conversion clock. This clock is active during the conversion time and the normal mode rejection provided by the internal digital filter is not very high at this frequency. A normal mode signal of this frequency at the converter reference terminals can result in DC gain and INL errors. A normal mode signal of this frequency at the converter input terminals can result in a DC offset error. Such perturbations can occur due to asymmetric capacitive coupling between the F_0 signal trace and the converter input and/or reference connection traces. An immediate solution is to maintain maximum possible separation between the F_0 signal trace and the input/reference signals. When the F_0 signal is parallel terminated near the

converter, substantial AC current is flowing in the loop formed by the F_0 connection trace, the termination and the ground return path. Thus, perturbation signals may be inductively coupled into the converter input and/or reference. In this situation, the user must reduce to a minimum the loop area for the F_0 signal as well as the loop area for the differential input and reference connections. Even when F_0 is not driven, other nearby signals pose similar EMI threats which will be minimized by following good layout practices.

Driving the Input and Reference

The input and reference pins of the LTC2480 converter are directly connected to a network of sampling capacitors. Depending upon the relation between the differential input voltage and the differential reference voltage, these capacitors are switching between these four pins transferring small amounts of charge in the process. A simplified equivalent circuit is shown in Figure 11.

For a simple approximation, the source impedance R_S driving an analog input pin (IN^+ , IN^- , V_{REF}^+ or GND) can be considered to form, together with R_{SW} and C_{EQ} (see Figure 11), a first order passive network with a time constant $\tau = (R_S + R_{SW}) \cdot C_{EQ}$. The converter is able to sample the input signal with better than 1ppm accuracy if the sampling period is at least 14 times greater than the input circuit time constant τ . The sampling process on the four input analog pins is quasi-independent so each time constant should be considered by itself and, under worst-case circumstances, the errors may add.

When using the internal oscillator, the LTC2480's front-end switched-capacitor network is clocked at 123kHz corresponding to an 8.1 μ s sampling period. Thus, for settling errors of less than 1ppm, the driving source impedance should be chosen such that $\tau \leq 8.1\mu\text{s}/14 = 580\text{ns}$. When an external oscillator of frequency f_{EOSC} is used, the sampling period is $2.5/f_{EOSC}$ and, for a settling error of less than 1ppm, $\tau \leq 0.178/f_{EOSC}$.

Automatic Differential Input Current Cancellation

In applications where the sensor output impedance is low (up to 10k Ω with no external bypass capacitor or up to 500 Ω with 0.001 μ F bypass), complete settling of the input

APPLICATIONS INFORMATION

occurs. In this case, no errors are introduced and direct digitization of the sensor is possible.

For many applications, the sensor output impedance combined with external bypass capacitors produces RC time constants much greater than the 580ns required for 1ppm accuracy. For example, a 10kΩ bridge driving a 0.1μF bypass capacitor has a time constant an order of magnitude greater than the required maximum. Historically, settling issues were solved using buffers. These buffers led to increased noise, reduced DC performance (Offset/Drift), limited input/output swing (cannot digitize signals near ground or V_{CC}), added system cost and increased power. The LTC2480 uses a proprietary switching algorithm that forces the average differential input current to zero independent of external settling errors. This allows accurate direct digitization of high impedance sensors without the need of buffers. Additional errors resulting from mismatched leakage currents must also be taken into account.

The switching algorithm forces the average input current on the positive input (I_{IN+}⁺) to be equal to the average input current on the negative input (I_{IN-}⁻). Over the complete conversion cycle, the average differential input current (I_{IN+}⁺ - I_{IN-}⁻) is zero. While the differential input current is

zero, the common mode input current (I_{IN+}⁺ + I_{IN-}⁻)/2 is proportional to the difference between the common mode input voltage (V_{INCM}) and the common mode reference voltage (V_{REFCM}).

In applications where the input common mode voltage is equal to the reference common mode voltage, as in the case of a balance bridge type application, both the differential and common mode input current are zero. The accuracy of the converter is unaffected by settling errors. Mismatches in source impedances between IN⁺ and IN⁻ also do not affect the accuracy.

In applications where the input common mode voltage is constant but different from the reference common mode voltage, the differential input current remains zero while the common mode input current is proportional to the difference between V_{INCM} and V_{REFCM}. For a reference common mode of 2.5V and an input common mode of 1.5V, the common mode input current is approximately 0.74μA (in simultaneous 50Hz/60Hz rejection mode). This common mode input current has no effect on the accuracy if the external source impedances tied to IN⁺ and IN⁻ are matched. Mismatches in these source impedances lead to a fixed offset error but do not affect the linearity or full-scale reading. A 1% mismatch in 1kΩ source resistances leads to a 15ppm shift (74μV) in offset voltage.

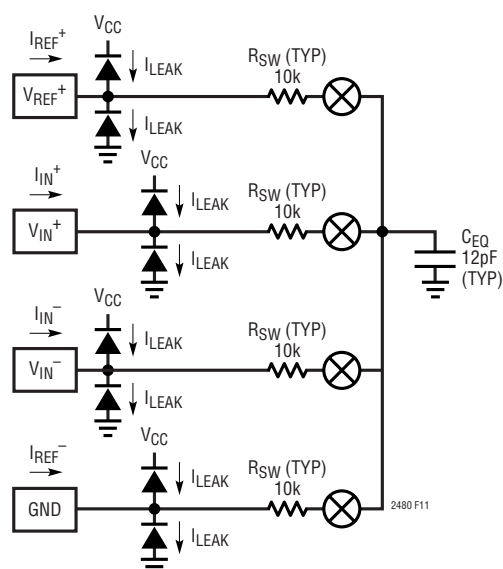

$$I(\text{IN}^+)_{\text{AVG}} = I(\text{IN}^-)_{\text{AVG}} = \frac{V_{\text{INCM}} - V_{\text{REFCM}}}{0.5 \cdot R_{\text{EQ}}}$$

$$I(\text{REF}^+)_{\text{AVG}} = \frac{1.5 \cdot V_{\text{REF}} - V_{\text{INCM}} + V_{\text{REFCM}}}{0.5 \cdot R_{\text{EQ}}} - \frac{V_{\text{IN}}^2}{V_{\text{REF}} \cdot R_{\text{EQ}}} - \frac{0.5 \cdot V_{\text{REF}} \cdot D_{\text{T}}}{R_{\text{EQ}}} \approx \frac{1.5V_{\text{REF}} + (V_{\text{REFCM}} - V_{\text{INCM}})}{0.5 \cdot R_{\text{EQ}}} - \frac{V_{\text{IN}}^2}{V_{\text{REF}} \cdot R_{\text{EQ}}}$$

where:

$$V_{\text{REFCM}} = \left(\frac{V_{\text{REF}^+}}{2} \right)$$

$$V_{\text{IN}} = \text{IN}^+ - \text{IN}^-$$

$$V_{\text{INCM}} = \left(\frac{\text{IN}^+ + \text{IN}^-}{2} \right)$$

R_{EQ} = 2.71MΩ INTERNAL OSCILLATOR 60Hz MODE

R_{EQ} = 2.98MΩ INTERNAL OSCILLATOR 50Hz AND 60Hz MODE

R_{EQ} = (0.833 • 10¹²) / f_{EOSC} EXTERNAL OSCILLATOR

D_T IS THE DENSITY OF A DIGITAL TRANSITION AT THE MODULATOR OUTPUT WHERE REF⁻ IS INTERNALLY TIED TO GND

SWITCHING FREQUENCY
f_{SW} = 123kHz INTERNAL OSCILLATOR
f_{SW} = 0.4 • f_{EOSC} EXTERNAL OSCILLATOR

Figure 11. LTC2480 Equivalent Analog Input Circuit

APPLICATIONS INFORMATION

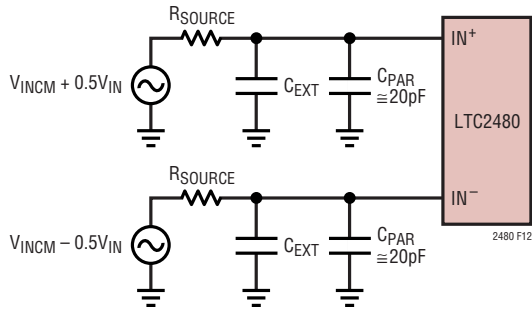

Figure 12. An RC Network at IN⁺ and IN⁻

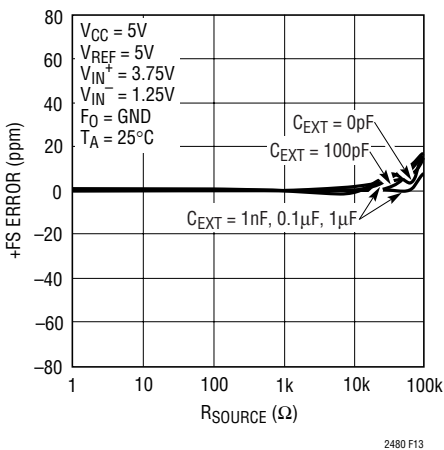

Figure 13. +FS Error vs R_{SOURCE} at IN⁺ or IN⁻

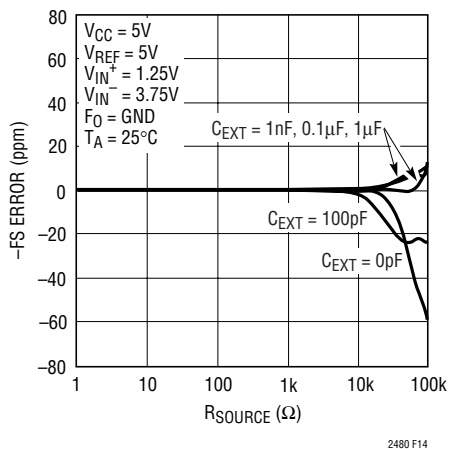

Figure 14. -FS Error vs R_{SOURCE} at IN⁺ or IN⁻

In applications where the common mode input voltage varies as a function of input signal level (single-ended input, RTDs, half bridges, current sensors, etc.), the

common mode input current varies proportionally with input voltage. For the case of balanced input impedances, the common mode input current effects are rejected by the large CMRR of the LTC2480 leading to little degradation in accuracy. Mismatches in source impedances lead to gain errors proportional to the difference between the common mode input voltage and the common mode reference voltage. 1% mismatches in 1kΩ source resistances lead to worst-case gain errors on the order of 15ppm or 1LSB (for 1V differences in reference and input common mode voltage). Table 7 summarizes the effects of mismatched source impedance and differences in reference/input common mode voltages.

Table 7. Suggested Input Configuration for LTC2480

	BALANCED INPUT RESISTANCES	UNBALANCED INPUT RESISTANCES
Constant $V_{IN(CM)} - V_{REF(CM)}$	$C_{EXT} > 1nF$ at Both IN ⁺ and IN ⁻ . Can Take Large Source Resistance with Negligible Error	$C_{EXT} > 1nF$ at Both IN ⁺ and IN ⁻ . Can Take Large Source Resistance. Unbalanced Resistance Results in an Offset Which Can be Calibrated
Varying $V_{IN(CM)} - V_{REF(CM)}$	$C_{EXT} > 1nF$ at Both IN ⁺ and IN ⁻ . Can Take Large Source Resistance with Negligible Error	Minimize IN ⁺ and IN ⁻ Capacitors and Avoid Large Source Impedance (<5k Recommended)

The magnitude of the dynamic input current depends upon the size of the very stable internal sampling capacitors and upon the accuracy of the converter sampling clock. The accuracy of the internal clock over the entire temperature and power supply range is typically better than 0.5%. Such a specification can also be easily achieved by an external clock. When relatively stable resistors (50ppm/°C) are used for the external source impedance seen by IN⁺ and IN⁻, the expected drift of the dynamic current and offset will be insignificant (about 1% of their respective values over the entire temperature and voltage range). Even for the most stringent applications, a one-time calibration operation may be sufficient.

In addition to the input sampling charge, the input ESD protection diodes have a temperature dependent leakage current. This current, nominally 1nA (±10nA max), results in a small offset shift. A 1k source resistance will create a 1µV typical and 10µV maximum offset voltage.

APPLICATIONS INFORMATION

Reference Current

In a similar fashion, the LTC2480 samples the differential reference pins V_{REF}^+ and GND transferring small amount of charge to and from the external driving circuits thus producing a dynamic reference current. This current does not change the converter offset, but it may degrade the gain and INL performance. The effect of this current can be analyzed in two distinct situations.

For relatively small values of the external reference capacitors ($C_{REF} < 1\text{nF}$), the voltage on the sampling capacitor settles almost completely and relatively large values for the source impedance result in only small errors. Such values for C_{REF} will deteriorate the converter offset and gain performance without significant benefits of reference filtering and the user is advised to avoid them.

Larger values of reference capacitors ($C_{REF} > 1\text{nF}$) may be required as reference filters in certain configurations. Such capacitors will average the reference sampling charge and the external source resistance will see a quasi constant reference differential impedance.

In the following discussion, it is assumed the input and reference common mode are the same. Using internal oscillator for 60Hz mode, the typical differential reference resistance is $1\text{M}\Omega$ which generates a full-scale ($V_{REF}/2$) gain error of 0.51ppm for each ohm of source resistance driving the V_{REF} pin. For 50Hz/60Hz mode, the related difference resistance is $1.1\text{M}\Omega$ and the resulting full-scale error is 0.46ppm for each ohm of source resistance driving the V_{REF} pin. For 50Hz mode, the related difference resistance is $1.2\text{M}\Omega$ and the resulting full-scale error is 0.42ppm for each ohm of source resistance driving the V_{REF} pin. When F_0 is driven by an external oscillator with a frequency f_{EOSC} (external conversion clock operation), the typical differential reference resistance is $0.30 \cdot 10^{12}/f_{EOSC} \Omega$ and each ohm of source resistance driving the V_{REF} pin will result in $1.67 \cdot 10^{-6} \cdot f_{EOSC}$ ppm gain error. The typical +FS and -FS errors for various combinations of source resistance seen by the V_{REF} pin and external capacitance connected to that pin are shown in Figures 15-18.

In addition to this gain error, the converter INL performance is degraded by the reference source impedance. The INL is caused by the input dependent terms

$-V_{IN}^2/(V_{REF} \cdot R_{EQ}) - (0.5 \cdot V_{REF} \cdot D_T)/R_{EQ}$ in the reference pin current as expressed in Figure 11. When using internal oscillator and 60Hz mode, every 100Ω of reference source resistance translates into about 0.67ppm additional INL error. When using internal oscillator and 50Hz/60Hz mode, every 100Ω of reference source resistance translates into about 0.61ppm additional INL error. When using internal oscillator and 50Hz mode, every 100Ω of reference source resistance translates into about 0.56ppm additional INL error. When F_0 is driven by an external oscillator with a frequency f_{EOSC} , every 100Ω of source resistance driving V_{REF} translates into about $2.18 \cdot 10^{-6} \cdot f_{EOSC}$ ppm additional INL error. Figure 19 shows the typical INL error due to the source resistance driving the V_{REF} pin when large C_{REF} values are used. The user is advised to minimize the source impedance driving the V_{REF} pin.

In applications where the reference and input common mode voltages are different, extra errors are introduced. For every 1V of the reference and input common mode voltage difference ($V_{REFCM} - V_{INCM}$) and a 5V reference, each Ohm of reference source resistance introduces an extra $(V_{REFCM} - V_{INCM})/(V_{REF} \cdot R_{EQ})$ full-scale gain error, which is 0.074ppm when using internal oscillator and 60Hz mode. When using internal oscillator and 50Hz/60Hz mode, the extra full-scale gain error is 0.067ppm. When using internal oscillator and 50Hz mode, the extra gain error is 0.061ppm. If an external clock is used, the corresponding extra gain error is $0.24 \cdot 10^{-6} \cdot f_{EOSC}$ ppm.

The magnitude of the dynamic reference current depends upon the size of the very stable internal sampling capacitors and upon the accuracy of the converter sampling clock. The accuracy of the internal clock over the entire temperature and power supply range is typically better than 0.5%. Such a specification can also be easily achieved by an external clock. When relatively stable resistors (50ppm/°C) are used for the external source impedance seen by V_{REF}^+ and GND, the expected drift of the dynamic current gain error will be insignificant (about 1% of its value over the entire temperature and voltage range). Even for the most stringent applications a one-time calibration operation may be sufficient.

In addition to the reference sampling charge, the reference pins ESD protection diodes have a temperature dependent

APPLICATIONS INFORMATION

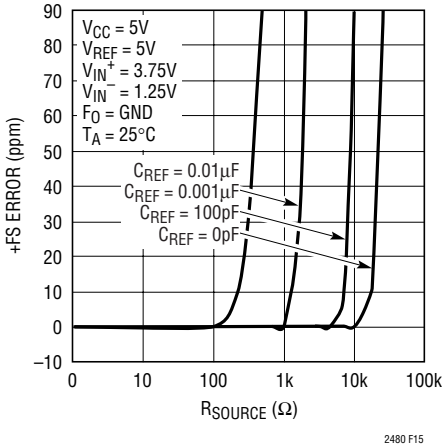

Figure 15. +FS Error vs R_{SOURCE} at V_{REF} (Small C_{REF})

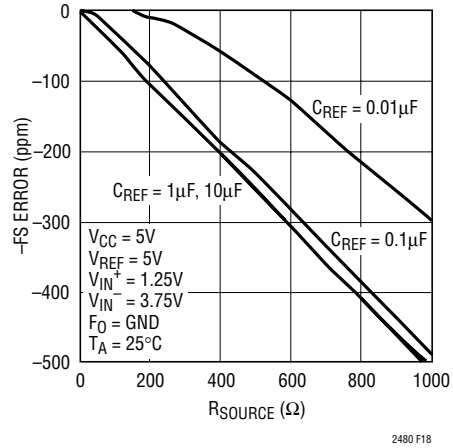

Figure 18. -FS Error vs R_{SOURCE} at V_{REF} (Large C_{REF})

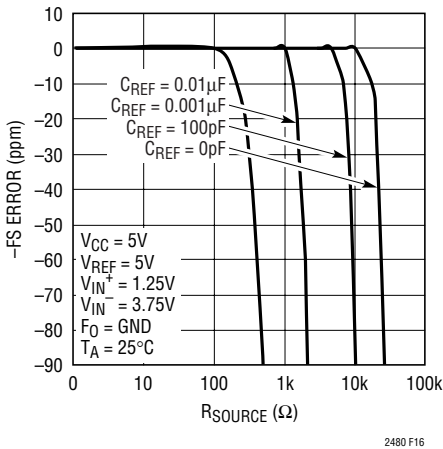

Figure 16. -FS Error vs R_{SOURCE} at V_{REF} (Small C_{REF})

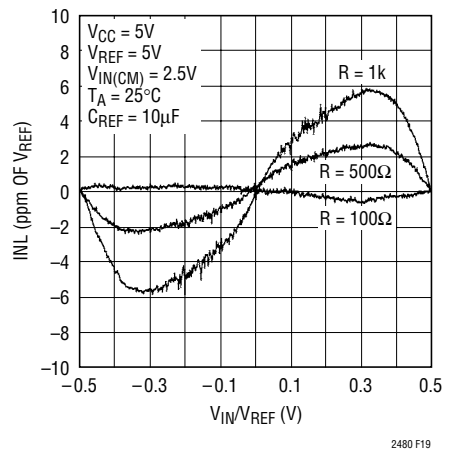

Figure 19. INL vs Differential Input Voltage and Reference Source Resistance for C_{REF} > 1μF

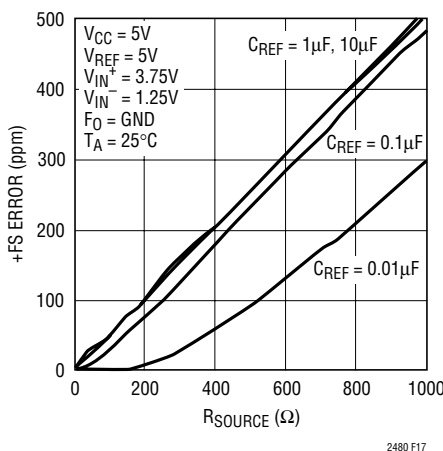

Figure 17. +FS Error vs R_{SOURCE} at V_{REF} (Large C_{REF})

leakage current. This leakage current, nominally 1nA (±10nA max), results in a small gain error. A 100Ω source resistance will create a 0.05μV typical and 0.5μV maximum full-scale error.

Output Data Rate

When using its internal oscillator, the LTC2480 produces up to 7.5 samples per second (sps) with a notch frequency of 60Hz, 6.25sps with a notch frequency of 50Hz and 6.82sps with the 50Hz/60Hz rejection mode. The actual output data rate will depend upon the length of the sleep and data output phases which are controlled by the user and which can be made insignificantly short. When operated with an external conversion clock (F_O connected to an

APPLICATIONS INFORMATION

external oscillator), the LTC2480 output data rate can be increased as desired. The duration of the conversion phase is $41036/f_{EOSC}$. If $f_{EOSC} = 307.2\text{kHz}$, the converter behaves as if the internal oscillator is used and the notch is set at 60Hz.

An increase in f_{EOSC} over the nominal 307.2kHz will translate into a proportional increase in the maximum output data rate. The increase in output rate is nevertheless accompanied by three potential effects, which must be carefully considered.

First, a change in f_{EOSC} will result in a proportional change in the internal notch position and in a reduction of the converter differential mode rejection at the power line frequency. In many applications, the subsequent performance degradation can be substantially reduced by relying upon the LTC2480's exceptional common mode rejection and by carefully eliminating common mode to differential mode conversion sources in the input circuit. The user should avoid single-ended input filters and should maintain a very high degree of matching and symmetry in the circuits driving the IN^+ and IN^- pins.

Second, the increase in clock frequency will increase proportionally the amount of sampling charge transferred through the input and the reference pins. If large external input and/or reference capacitors (C_{IN} , C_{REF}) are used, the previous section provides formulae for evaluating the effect of the source resistance upon the converter performance for any value of f_{EOSC} . If small external input and/or reference capacitors (C_{IN} , C_{REF}) are used, the effect of the external source resistance upon the LTC2480 typical performance can be inferred from Figures 13, 14, 15 and 16 in which the horizontal axis is scaled by $307200/f_{EOSC}$.

Third, an increase in the frequency of the external oscillator above 1MHz (a more than $3\times$ increase in the output data rate) will start to decrease the effectiveness of the internal autocalibration circuits. This will result in a progressive degradation in the converter accuracy and linearity. Typical measured performance curves for output data rates up to 100 readings per second are shown in Figures 20 to 27. In order to obtain the highest possible level of accuracy from this converter at output data rates above 20 readings per second, the user is advised to maximize the power supply voltage used and to limit the maximum ambient operating

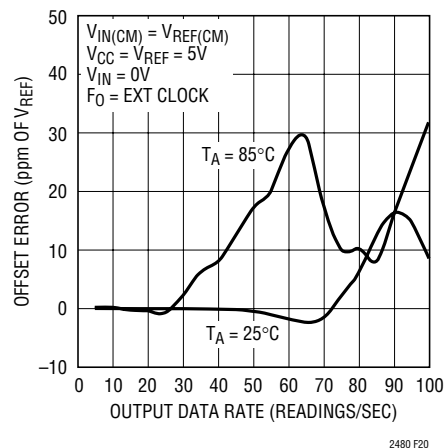

Figure 20. Offset Error vs Output Data Rate and Temperature

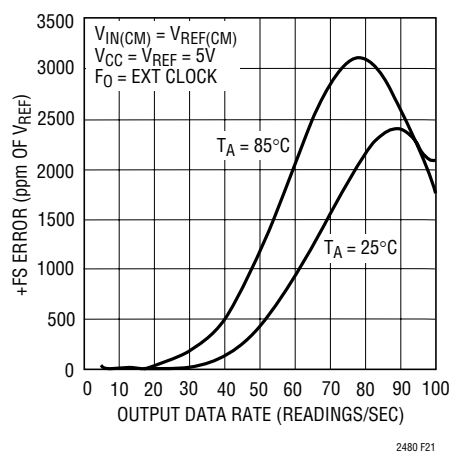

Figure 21. +FS Error vs Output Data Rate and Temperature

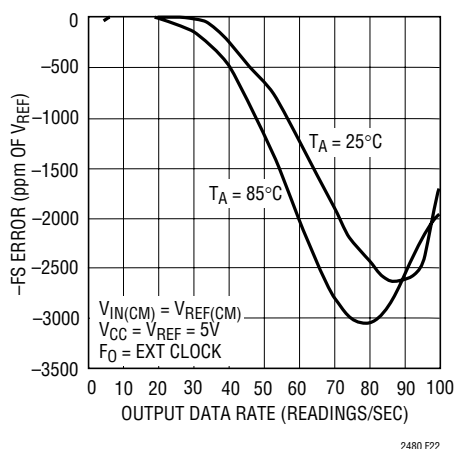

Figure 22. -FS Error vs Output Data Rate and Temperature

APPLICATIONS INFORMATION

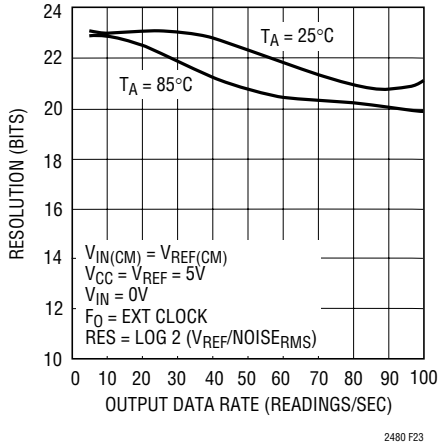

Figure 23. Resolution ($Noise_{RMS} \leq 1LSB$) vs Output Data Rate and Temperature

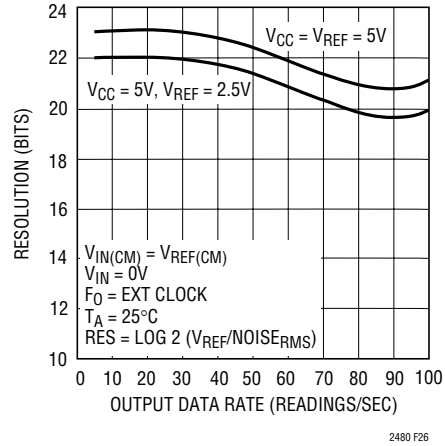

Figure 26. Resolution ($Noise_{RMS} \leq 1LSB$) vs Output Data Rate and Reference Voltage

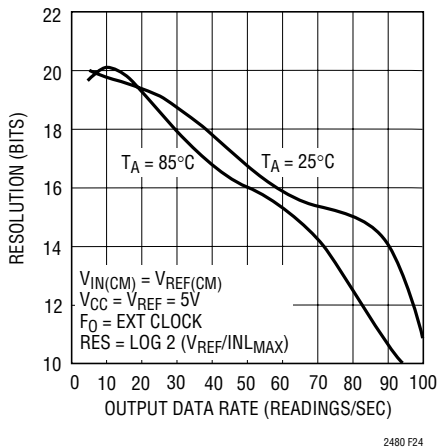

Figure 24. Resolution ($INL_{MAX} \leq 1LSB$) vs Output Data Rate and Temperature

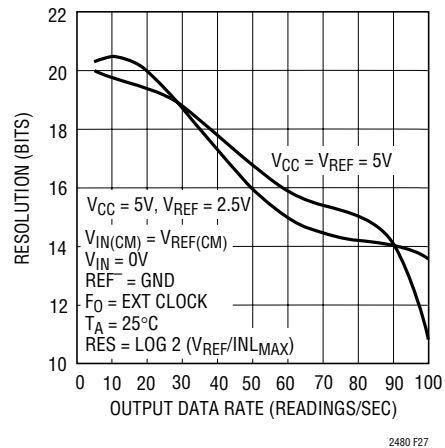

Figure 27. Resolution ($INL_{MAX} \leq 1LSB$) vs Output Data Rate and Reference Voltage

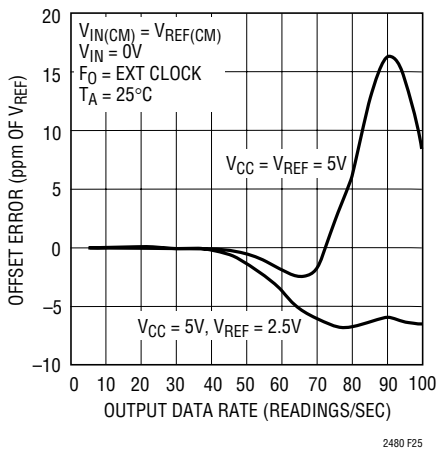

Figure 25. Offset Error vs Output Data Rate and Reference Voltage

temperature. In certain circumstances, a reduction of the differential reference voltage may be beneficial.

Input Bandwidth

The combined effect of the internal SINC⁴ digital filter and of the analog and digital autocalibration circuits determines the LTC2480 input bandwidth. When the internal oscillator is used with the notch set at 60Hz, the 3dB input bandwidth is 3.63Hz. When the internal oscillator is used with the notch set at 50Hz, the 3dB input bandwidth is 3.02Hz. If an external conversion clock generator of frequency f_{EOSC} is connected to the F_0 pin, the 3dB input bandwidth is $11.8 \cdot 10^{-6} \cdot f_{EOSC}$.

APPLICATIONS INFORMATION

Due to the complex filtering and calibration algorithms utilized, the converter input bandwidth is not modeled very accurately by a first order filter with the pole located at the 3dB frequency. When the internal oscillator is used, the shape of the LTC2480 input bandwidth is shown in Figure 28. When an external oscillator of frequency f_{EOSC} is used, the shape of the LTC2480 input bandwidth can be derived from Figure 28, 60Hz mode curve in which the horizontal axis is scaled by $f_{EOSC}/307200$.

The conversion noise ($600nV_{RMS}$ typical for $V_{REF} = 5V$) can be modeled by a white noise source connected to a noise free converter. The noise spectral density is $47nV/\sqrt{Hz}$ for an infinite bandwidth source and $64nV/\sqrt{Hz}$ for a single 0.5MHz pole source. From these numbers, it is clear that particular attention must be given to the design of external amplification circuits. Such circuits face the simultaneous requirements of very low bandwidth (just a few Hz) in order to reduce the output referred noise and relatively high bandwidth (at least 500kHz) necessary to drive the input switched-capacitor network. A possible solution is a high gain, low bandwidth amplifier stage followed by a high bandwidth unity-gain buffer.

When external amplifiers are driving the LTC2480, the ADC input referred system noise calculation can be simplified by Figure 29. The noise of an amplifier driving the LTC2480 input pin can be modeled as a band limited white noise source. Its bandwidth can be approximated by the bandwidth of a single pole lowpass filter with a corner frequency f_i . The amplifier noise spectral density is n_i . From Figure 29, using f_i as the x-axis selector, we can find on the y-axis the noise equivalent bandwidth $freq_i$ of the input driving amplifier. This bandwidth includes the band limiting effects of the ADC internal calibration and filtering. The noise of the driving amplifier referred to the converter input and including all these effects can be calculated as $N = n_i \cdot \sqrt{freq_i}$. The total system noise (referred to the LTC2480 input) can now be obtained by summing as square root of sum of squares the three ADC input referred noise sources: the LTC2480 internal noise, the noise of the IN^+ driving amplifier and the noise of the IN^- driving amplifier.

If the F_0 pin is driven by an external oscillator of frequency f_{EOSC} , Figure 29 can still be used for noise calculation if the

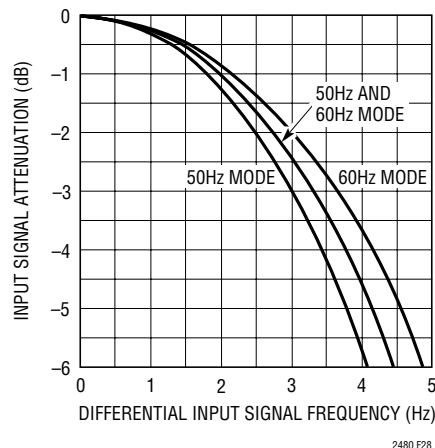

Figure 28. Input Signal Bandwidth Using the Internal Oscillator

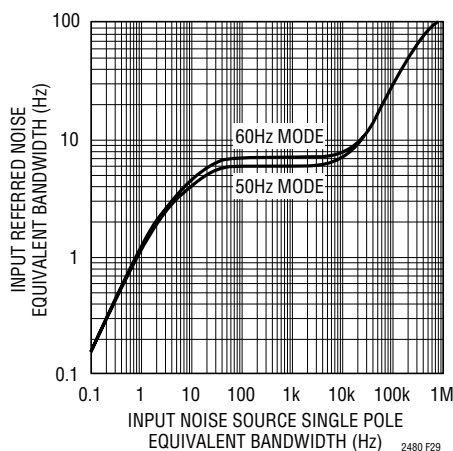

Figure 29. Input Referred Noise Equivalent Bandwidth of an Input Connected White Noise Source

x-axis is scaled by $f_{EOSC}/307200$. For large values of the ratio $f_{EOSC}/307200$, the Figure 29 plot accuracy begins to decrease, but at the same time the LTC2480 noise floor rises and the noise contribution of the driving amplifiers lose significance.

Normal Mode Rejection and Antialiasing

One of the advantages delta-sigma ADCs offer over conventional ADCs is on-chip digital filtering. Combined with a large oversampling ratio, the LTC2480 significantly simplifies antialiasing filter requirements. Additionally, the input current cancellation feature of the LTC2480 allows external lowpass filtering without degrading the DC performance of the device.

APPLICATIONS INFORMATION

The SINC⁴ digital filter provides greater than 120dB normal mode rejection at all frequencies except DC and integer multiples of the modulator sampling frequency (f_S). The LTC2480's autocalibration circuits further simplify the antialiasing requirements by additional normal mode signal filtering both in the analog and digital domain. Independent of the operating mode, $f_S = 256 \cdot f_N = 2048 \cdot f_{OUTMAX}$ where f_N is the notch frequency and f_{OUTMAX} is the maximum output data rate. In the internal oscillator mode with a 50Hz notch setting, $f_S = 12800\text{Hz}$, with 50Hz/60Hz rejection, $f_S = 13960\text{Hz}$ and with a 60Hz notch setting $f_S = 15360\text{Hz}$. In the external oscillator mode, $f_S = f_{EOSC}/20$. The performance of the normal mode rejection is shown in Figures 30 and 31.

In 1x speed mode, the regions of low rejection occurring at integer multiples of f_S have a very narrow bandwidth. Magnified details of the normal mode rejection curves are shown in Figure 32 (rejection near DC) and Figure 33 (rejection at $f_S = 256f_N$) where f_N represents the notch frequency. These curves have been derived for the external oscillator mode but they can be used in all operating modes by appropriately selecting the f_N value.

The user can expect to achieve this level of performance using the internal oscillator as it is demonstrated by Figures 34, 35 and 36. Typical measured values of the normal mode rejection of the LTC2480 operating with an internal oscillator and a 60Hz notch setting are shown in Figure 34

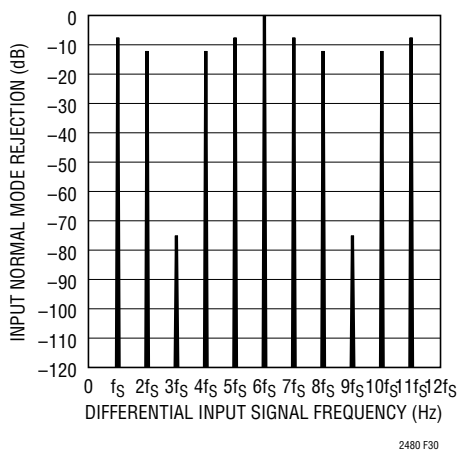

Figure 30. Input Normal Mode Rejection, Internal Oscillator and 50Hz Notch Mode

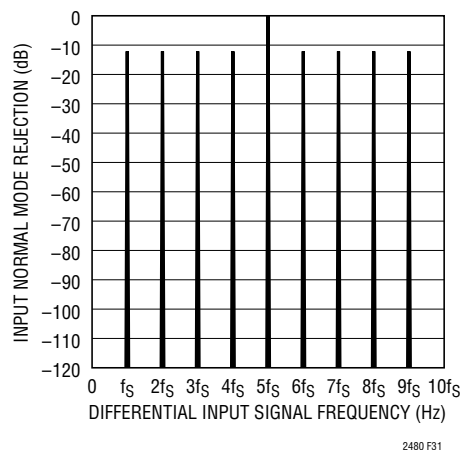

Figure 31. Input Normal Mode Rejection, Internal Oscillator and 60Hz Notch Mode or External Oscillator

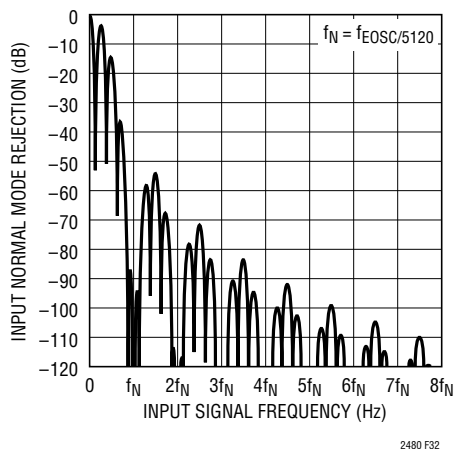

Figure 32. Input Normal Mode Rejection at DC

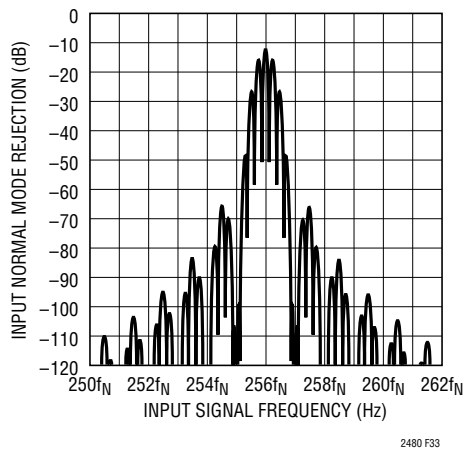

Figure 33. Input Normal Mode Rejection at $f_S = 256f_N$

APPLICATIONS INFORMATION

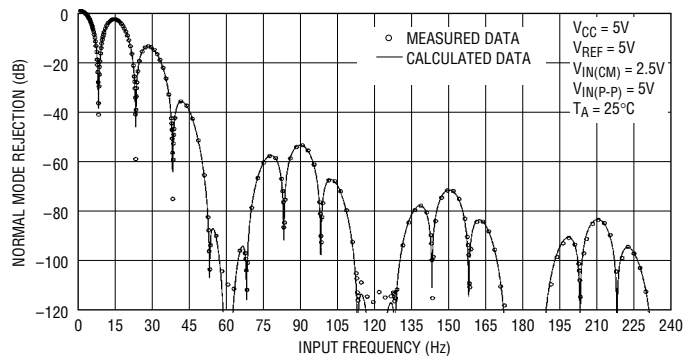

Figure 34. Input Normal Mode Rejection vs Input Frequency with Input Perturbation of 100% Full Scale (60Hz Notch)

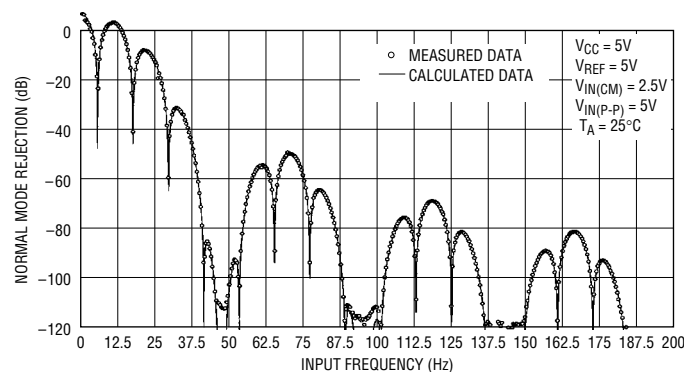

Figure 35. Input Normal Mode Rejection vs Input Frequency with Input Perturbation of 100% Full Scale (50Hz Notch)

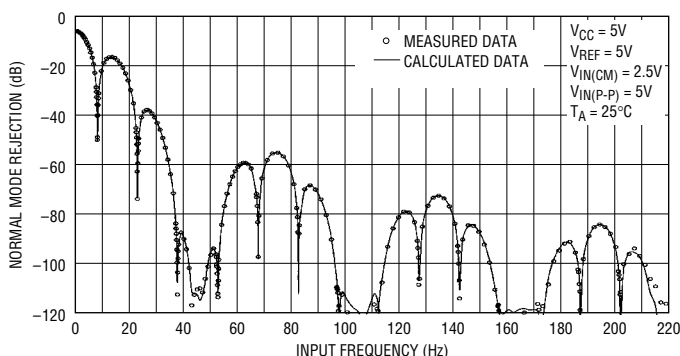

Figure 36. Input Normal Mode Rejection vs Input Frequency with Input Perturbation of 100% Full Scale (50Hz/60Hz Mode)

superimposed over the theoretical calculated curve. Similarly, the measured normal mode rejection of the LTC2480 for the 50Hz rejection mode and 50Hz/60Hz rejection mode are shown in Figures 35 and 36.

As a result of these remarkable normal mode specifications, minimal (if any) antialias filtering is required in front of the LTC2480. If passive RC components are placed in front of the LTC2480, the input dynamic current should be considered (see Input Current section). In this case, the differential input current cancellation feature of the LTC2480 allows external RC networks without significant degradation in DC performance.

Traditional high order delta-sigma modulators, while providing very good linearity and resolution, suffer from potential instabilities at large input signal levels. The proprietary architecture used for the LTC2480 third order modulator resolves this problem and guarantees a predictable stable behavior at input signal levels of up to 150% of full scale. In many industrial applications, it is not uncommon to have to measure microvolt level signals superimposed over volt level perturbations and the LTC2480 is eminently suited for such tasks. When the perturbation is differential, the specification of interest is the normal mode rejection for large input signal levels. With a reference voltage $V_{REF} = 5V$, the LTC2480 has a full-scale differential input range of 5V peak-to-peak. Figures 37 and 38 show measurement results for the LTC2480 normal mode rejection ratio with a 7.5V peak-to-peak (150% of full scale) input signal superimposed over the more traditional normal mode rejection ratio results obtained with a 5V peak-to-peak (full scale) input signal. In Figure 37, the LTC2480 uses the internal oscillator with the notch set at 60Hz ($F_0 = LOW$) and in Figure 38 it uses the internal oscillator with the notch set at 50Hz. It is clear that the LTC2480 rejection performance is maintained with no compromises in this extreme situation. When operating with large input signal levels, the user must observe that such signals do not violate the device absolute maximum ratings.

Using the 2x speed mode of the LTC2480, the device bypasses the digital offset calibration operation to double the output data rate. The superior normal mode rejection is maintained as shown in Figures 30 and 31. However, the magnified details near DC and $f_S = 256f_N$ are different, see Figures 39 and 40. In 2x speed mode, the bandwidth is 11.4Hz for the 50Hz rejection mode, 13.6Hz for the 60Hz rejection mode and 12.4Hz for the 50Hz/60Hz rejection

APPLICATIONS INFORMATION

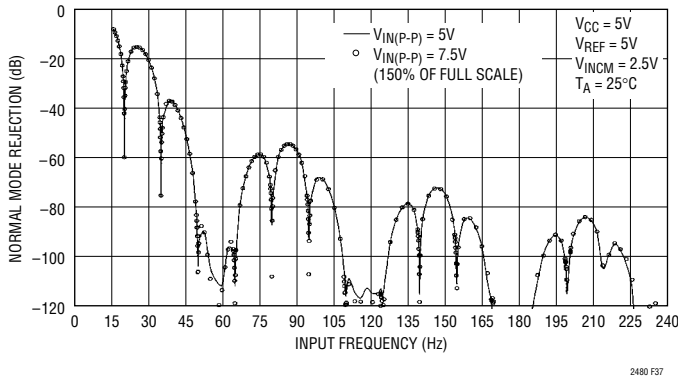

Figure 37. Measured Input Normal Mode Rejection vs Input Frequency with Input Perturbation of 150% Full Scale (60Hz Notch)

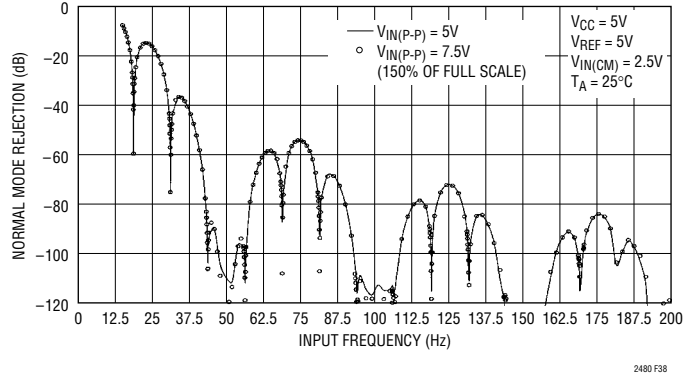

Figure 38. Measured Input Normal Mode Rejection vs Input Frequency with Input Perturbation of 150% Full Scale (50Hz Notch)

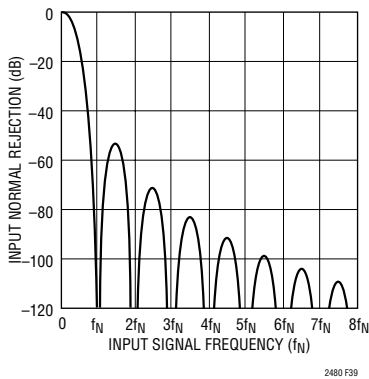

Figure 39. Input Normal Mode Rejection 2x Speed Mode

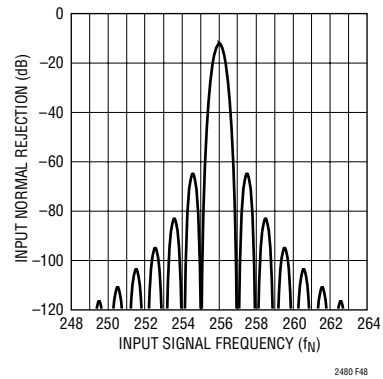

Figure 40. Input Normal Mode Rejection 2x Speed Mode

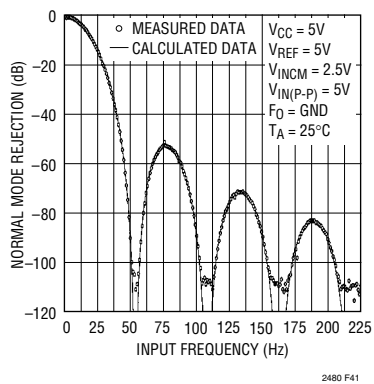

Figure 41. Input Normal Mode Rejection vs Input Frequency, 2x Speed Mode and 50Hz/60Hz Mode

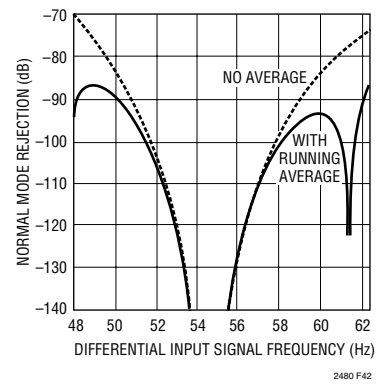

Figure 42. Input Normal Mode Rejection 2x Speed Mode

mode. Typical measured values of the normal mode rejection of the LTC2480 operating with the internal oscillator and 2x speed mode is shown in Figure 41.

When the LTC2480 is configured in 2x speed mode, by performing a running average, a SINC¹ notch is combined with the SINC⁴ digital filter, yielding the normal mode

LTC2480

APPLICATIONS INFORMATION

```
/** read_LTC2480() *****
This is the function that actually does all the work of talking to the LTC2480.
The spi_read() function performs an 8 bit bidirectional transfer on the SPI bus.
Data changes state on falling clock edges and is valid on rising edges, as
determined by the setup_spi() line in the initialize() function.
```

A good starting point when porting to other processors is to write your own `spi_write` function. Note that each processor has its own way of configuring the SPI port, and different compilers may or may not have built-in functions for the SPI port. Also, since the state of the LTC2480's SDO line indicates when a conversion is complete you need to be able to read the state of this line through the processor's serial data input. Most processors will let you read this pin as if it were a general purpose I/O line, but there may be some that don't.

When in doubt, you can always write a "bit bang" function for troubleshooting purposes.

The "fourbytes" structure allows byte access to the 32 bit return value:

```
struct fourbytes // Define structure of four consecutive bytes
{
    int8 te0; // To allow byte access to a 32 bit int or float.
    int8 te1; //
    int8 te2; // The make32() function in this compiler will
    int8 te3; // also work, but a union of 4 bytes and a 32 bit int
              // is probably more portable.
};
```

Also note that the lower 4 bits are the configuration word from the previous conversion. The 4 LSBs are cleared so that they don't affect any subsequent mathematical operations. While you can do a right shift by 4, there is no point if you are going to convert to floating point numbers - just adjust your scaling constants appropriately.

```
*****/
signed int32 read_LTC2480(char config)
{
    union
    {
        signed int32 bits32; // adc_code.bits32 all 32 bits
        struct fourbytes by; // adc_code.by.te0 byte 0
        } adc_code; // adc_code.by.te1 byte 1
                  // adc_code.by.te2 byte 2
                  // adc_code.by.te3 byte 3

    output_low(CS); // Enable LTC2480 SPI interface
    while(input(PIN_C4)) {} // Wait for end of conversion. The longest
                           // you will ever wait is one whole conversion period

    // Now is the time to switch any multiplexers because the conversion is finished
    // and you have the whole data output time for things to settle.

    adc_code.by.te3 = 0; // Set upper byte to zero.
    adc_code.by.te2 = spi_read(config); // Read first byte, send config byte
    adc_code.by.te1 = spi_read(0); // Read 2nd byte, send speed bit
    adc_code.by.te0 = spi_read(0); // Read 3rd byte. '0' argument is necessary
                                   // to act as SPI master!! (compiler
                                   // and processor specific.)

    output_high(CS); // Disable LTC2480 SPI interface

    // Clear configuration bits and subtract offset. This results in
    // a 2's complement 32 bit integer with the LTC2480's MSB in the 2^20 position
    adc_code.by.te0 = adc_code.by.te0 & 0xF0;
    adc_code.bits32 = adc_code.bits32 - 0x00200000;

    return adc_code.bits32;
} // End of read_LTC2480()
```

LTC2480

TYPICAL APPLICATION

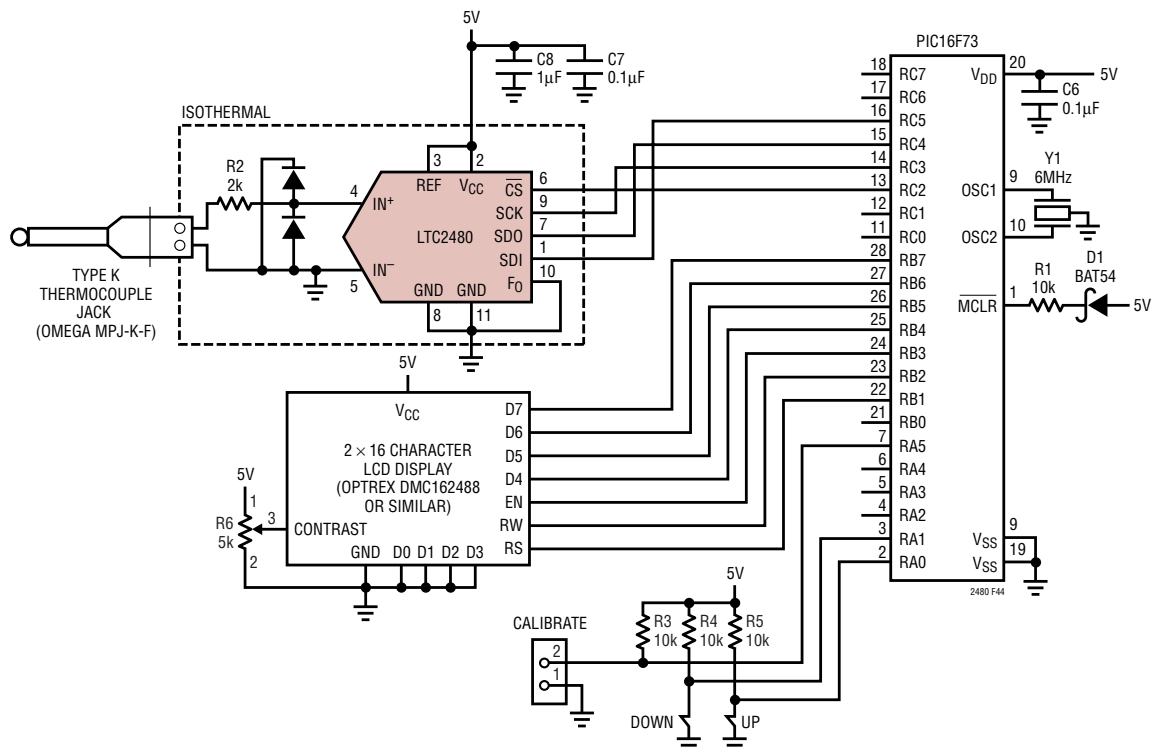

Figure 44. Complete Type K Thermocouple Meter

RELATED PARTS

PART NUMBER	DESCRIPTION	COMMENTS
LTC1050	Precision Chopper Stabilized Op Amp	No External Components 5 μ V Offset, 1.6 μ V _{p-p} Noise
LT1236A-5	Precision Bandgap Reference, 5V	0.05% Max Initial Accuracy, 5ppm/ $^{\circ}$ C Drift
LT1460	Micropower Series Reference	0.075% Max Initial Accuracy, 10ppm/ $^{\circ}$ C Max Drift
LTC2400	24-Bit, No Latency $\Delta\Sigma$ ADC in SO-8	0.3ppm Noise, 4ppm INL, 10ppm Total Unadjusted Error, 200 μ A
LTC2401/LTC2402	1-/2-Channel, 24-Bit, No Latency $\Delta\Sigma$ ADCs in MSOP	0.6ppm Noise, 4ppm INL, 10ppm Total Unadjusted Error, 200 μ A
LTC2404/LTC2408	4-/8-Channel, 24-Bit, No Latency $\Delta\Sigma$ ADCs with Differential Inputs	0.3ppm Noise, 4ppm INL, 10ppm Total Unadjusted Error, 200 μ A
LTC2410	24-Bit, No Latency $\Delta\Sigma$ ADC with Differential Inputs	0.8 μ V _{RMS} Noise, 2ppm INL
LTC2411/LTC2411-1	24-Bit, No Latency $\Delta\Sigma$ ADCs with Differential Inputs in MSOP	1.45 μ V _{RMS} Noise, 4ppm INL, Simultaneous 50Hz/60Hz Rejection (LTC2411-1)
LTC2413	24-Bit, No Latency $\Delta\Sigma$ ADC with Differential Inputs	Simultaneous 50Hz/60Hz Rejection, 800nV _{RMS} Noise
LTC2415/LTC2415-1	24-Bit, No Latency $\Delta\Sigma$ ADCs with 15Hz Output Rate	Pin Compatible with the LTC2410
LTC2414/LTC2418	8-/16-Channel 24-Bit, No Latency $\Delta\Sigma$ ADCs	0.2ppm Noise, 2ppm INL, 3ppm Total Unadjusted Errors 200 μ A
LTC2420	20-Bit, No Latency $\Delta\Sigma$ ADC in SO-8	1.2ppm Noise, 8ppm INL, Pin Compatible with LTC2400
LTC2430/LTC2431	20-Bit, No Latency $\Delta\Sigma$ ADCs with Differential Inputs	2.8 μ V Noise, SSOP-16/MSOP Package
LTC2435/LTC2435-1	20-Bit, No Latency $\Delta\Sigma$ ADCs with 15Hz Output Rate	3ppm INL, Simultaneous 50Hz/60Hz Rejection
LTC2440	High Speed, Low Noise 24-Bit $\Delta\Sigma$ ADC	3.5kHz Output Rate, 200nV Noise, 24.6 ENOBs
LTC2482	16-Bit $\Delta\Sigma$ ADC with Easy Drive Inputs	Pin Compatible with LTC2480/LTC2484
LTC2484	24-Bit $\Delta\Sigma$ ADC with Easy Drive Inputs	Pin Compatible with LTC2480/LTC2482