



+5V to ±10V Voltage Converters

General Description

The MAX680/MAX681 are monolithic, CMOS, dual charge-pump voltage converters that provide ±10V outputs from a +5V input voltage. The MAX680/MAX681 provide both a positive step-up charge pump to develop +10V from +5V input and an inverting charge pump to generate the -10V output. Both parts have an on-chip, 8kHz oscillator. The MAX681 has the capacitors internal to the package, and the MAX680 requires four external capacitors to produce both positive and negative voltages from a single supply.

The output source impedances are typically 150Ω, providing useful output currents up to 10mA. The low quiescent current and high efficiency make this device suitable for a variety of applications that need both positive and negative voltages generated from a single supply.

The MAX864/MAX865 are also recommended for new designs. The MAX864 operates at up to 200kHz and uses smaller capacitors. The MAX865 comes in the smaller μMAX package.

Applications

The MAX680/MAX681 can be used wherever a single positive supply is available and where positive and negative voltages are required. Common applications include generating ±6V from a 3V battery and generating ±10V from the standard +5V logic supply (for use with analog circuitry). Typical applications include:

- ±6V from 3V Lithium Cell
- Hand-Held Instruments
- Data-Acquisition Systems
- Panel Meters
- ±10V from +5V Logic Supply
- Battery-Operated Equipment
- Operational Amplifier Power Supplies

Pin Configurations

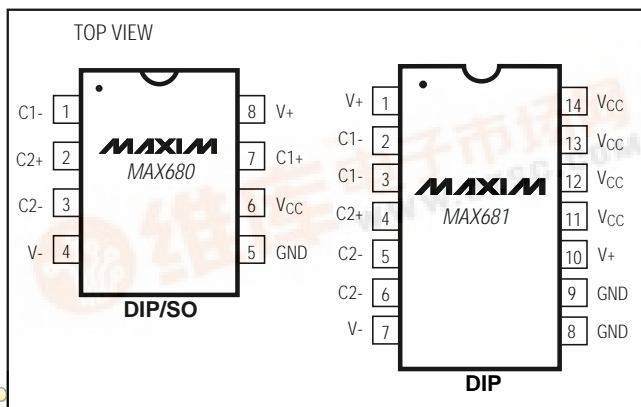

Features

- ◆ 95% Voltage-Conversion Efficiency
- ◆ 85% Power-Conversion Efficiency
- ◆ +2V to +6V Voltage Range
- ◆ Only Four External Capacitors Required (MAX680)
- ◆ No Capacitors Required (MAX681)
- ◆ 500μA Supply Current
- ◆ Monolithic CMOS Design

Ordering Information

PART	TEMP. RANGE	PIN-PACKAGE
MAX680CPA	0°C to +70°C	8 Plastic DIP
MAX680CSA	0°C to +70°C	8 Narrow SO
MAX680C/D	0°C to +70°C	Dice
MAX680EPA	-40°C to +85°C	8 Plastic DIP
MAX680ESA	-40°C to +85°C	8 Narrow SO
MAX680MJA	-55°C to +125°C	8 CERDIP
MAX681CPD	0°C to +70°C	14 Plastic DIP
MAX681EPD	-40°C to +85°C	14 Plastic DIP

Typical Operating Circuits

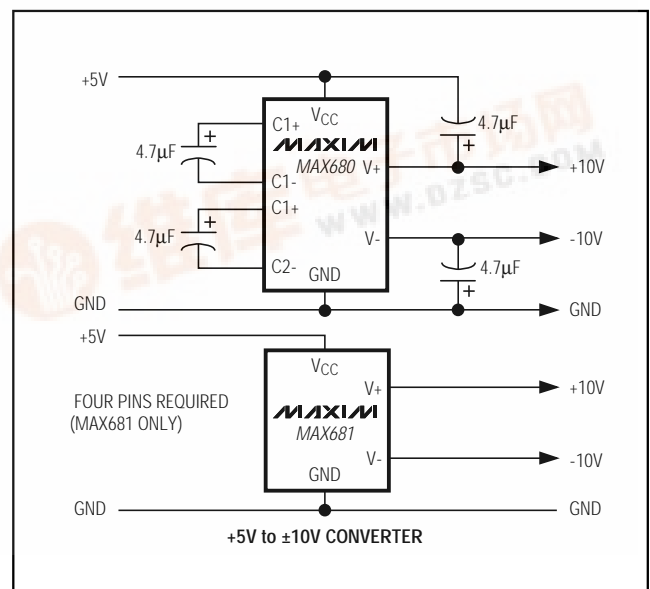

MAX680/MAX681

+5V to ±10V Voltage Converters

ABSOLUTE MAXIMUM RATINGS

V _{CC}	+6.2V
V ₊	+12V
V ₋	-12V
V ₋ Short-Circuit Duration	Continuous
V ₊ Current	75mA
V _{CC} ΔV/ΔT	1V/μs

Continuous Power Dissipation (T _A = +70°C)	
8-Pin Plastic DIP (derate 9.09mW/°C above +70°C)	727mW
8-Pin Narrow SO (derate 5.88mW/°C above +70°C)	471mW
8-Pin CERDIP (derate 8.00mW/°C above +70°C)	640mW
14-Pin Plastic DIP (derate 10.00mW/°C above +70°C)	800mW
Storage Temperature Range	-65°C to +160°C
Lead Temperature (soldering, 10sec)	+300°C

Stresses beyond those listed under "Absolute Maximum Ratings" may cause permanent damage to the device. These are stress ratings only, and functional operation of the device at these or any other conditions beyond those indicated in the operational sections of the specifications is not implied. Exposure to absolute maximum rating conditions for extended periods may affect device reliability.

ELECTRICAL CHARACTERISTICS

(V_{CC} = +5V, test circuit Figure 1, T_A = +25°C, unless otherwise noted.)

PARAMETER	CONDITIONS	MIN	TYP	MAX	UNITS	
Supply Current	V _{CC} = 3V, T _A = +25°C, R _L = ∞		0.5	1	mA	
	V _{CC} = 5V, T _A = +25°C, R _L = ∞		1	2		
	V _{CC} = 5V, 0°C ≤ T _A ≤ +70°C, R _L = ∞			2.5		
	V _{CC} = 5V, -40°C ≤ T _A ≤ +85°C, R _L = ∞			3		
	V _{CC} = 5V, -55°C ≤ T _A ≤ +125°C, R _L = ∞			3		
Supply-Voltage Range	MIN ≤ T _A ≤ MAX, R _L = 10kΩ	2.0	1.5 to 6.0	6.0	V	
Positive Charge-Pump Output Source Resistance	I _{L+} = 10mA, I _{L-} = 0mA, V _{CC} = 5V, T _A = +25°C		150	250	Ω	
	I _{L+} = 5mA, I _{L-} = 0mA, V _{CC} = 2.8V, T _A = +25°C		180	300		
	I _{L+} = 10mA, I _{L-} = 0mA, V _{CC} = 5V	0°C ≤ T _A ≤ +70°C				325
		-40°C ≤ T _A ≤ +85°C				350
Negative Charge-Pump Output Source Resistance	I _{L-} = 10mA, I _{L+} = 0mA, V ₊ = 10V, T _A = +25°C		90	150	Ω	
		I _{L-} = 5mA, I _{L+} = 0mA, V ₊ = 5.6V, T _A = +25°C		110		175
	I _{L-} = 10mA, I _{L+} = 0mA, V ₊ = 10V	0°C ≤ T _A ≤ +70°C				200
		-40°C ≤ T _A ≤ +85°C				200
	-55°C ≤ T _A ≤ +125°C			250		
Oscillator Frequency		4	8		kHz	
Power Efficiency	R _L = 10kΩ		85		%	
Voltage-Conversion Efficiency	V ₊ , R _L = ∞	95	99		%	
	V ₋ , R _L = ∞	90	97			

+5V to ±10V Voltage Converters

Typical Operating Characteristics

($T_A = +25^\circ\text{C}$, unless otherwise noted.)

MAX680/MAX681

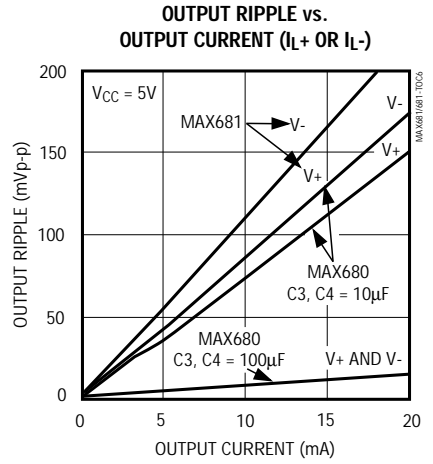
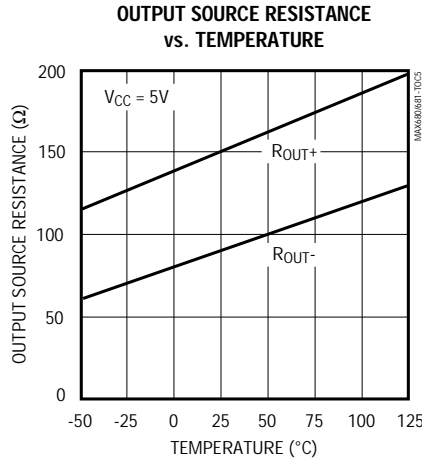
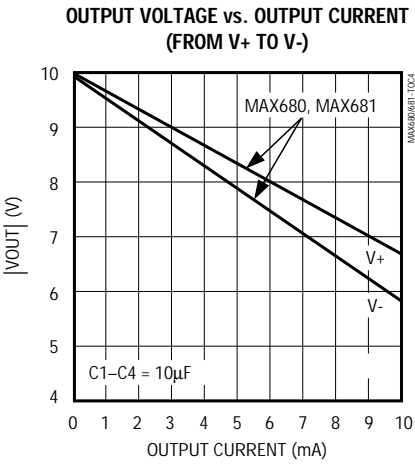
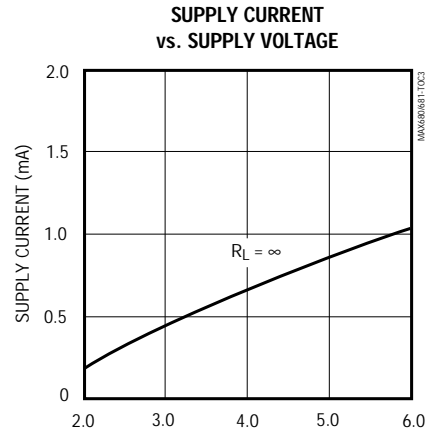
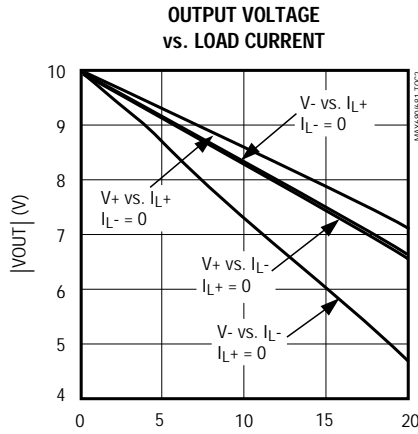
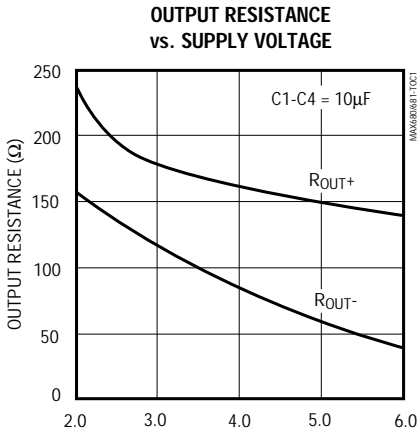

+5V to ±10V Voltage Converters

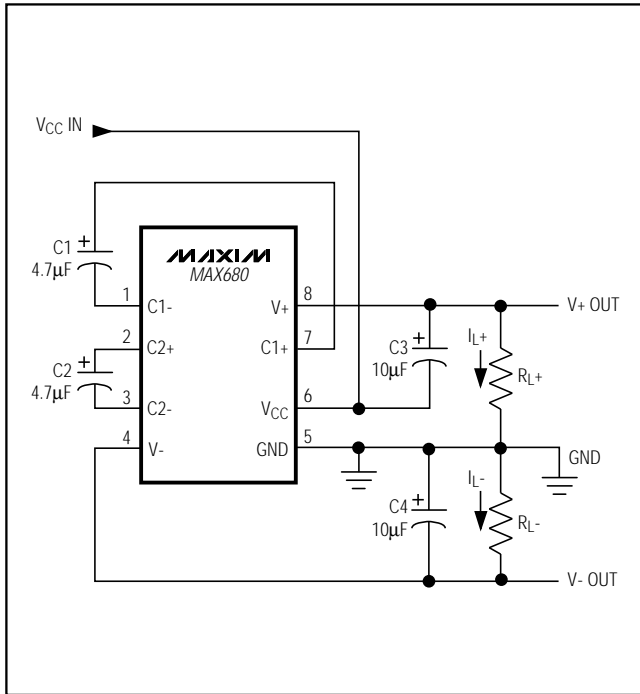

Figure 1. Test Circuit

Detailed Description

The MAX681 contains all circuitry needed to implement a dual charge pump. The MAX680 needs only four capacitors. These may be inexpensive electrolytic capacitors with values in the $1\mu\text{F}$ to $100\mu\text{F}$ range. The MAX681 contains two $1.5\mu\text{F}$ capacitors as C1 and C2, and two $2.2\mu\text{F}$ capacitors as C3 and C4. See *Typical Operating Characteristics*.

Figure 2a shows the idealized operation of the positive voltage converter. The on-chip oscillator generates a 50% duty-cycle clock signal. During the first half of the cycle, switches S2 and S4 are open, S1 and S3 are closed, and capacitor C1 is charged to the input voltage V_{CC} . During the second half-cycle, S1 and S3 are open, S2 and S4 are closed, and C1 is translated upward by V_{CC} volts. Assuming ideal switches and no load on C3, charge is transferred onto C3 from C1 such that the voltage on C3 will be $2V_{CC}$, generating the positive supply.

Figure 2b shows the negative converter. The switches of the negative converter are out of phase from the positive converter. During the second half of the clock cycle, S6 and S8 are open and S5 and S7 are closed, charging C2 from V_+ (pumped up to $2V_{CC}$ by the positive charge pump) to GND. In the first half of the clock

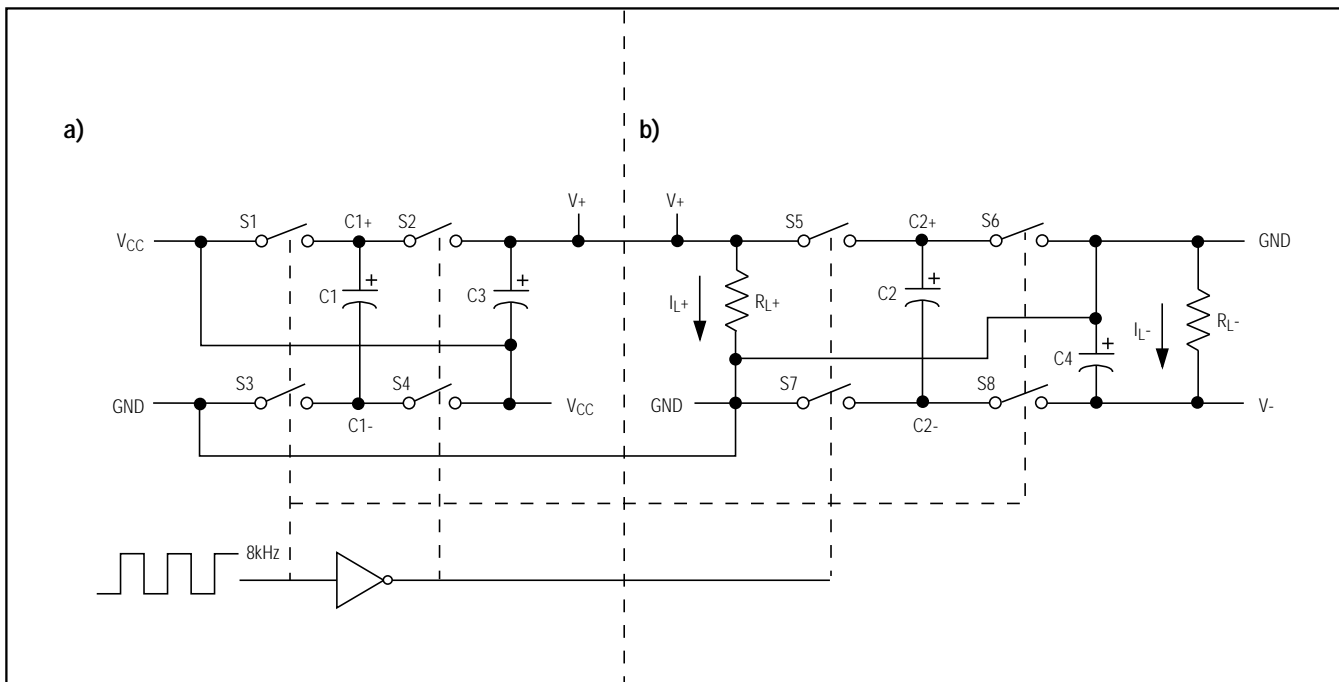

Figure 2. Idealized Voltage Quadrupler: a) Positive Charge Pump; b) Negative Charge Pump

+5V to ±10V Voltage Converters

cycle, S5 and S7 are open, S6 and S8 are closed, and the charge on C2 is transferred to C4, generating the negative supply. The eight switches are CMOS power MOSFETs. S1, S2, S4, and S5 are P-channel switches, while S3, S6, S7, and S8 are N-channel switches.

Efficiency Considerations

Theoretically, a charge-pump voltage multiplier can approach 100% efficiency under the following conditions:

- The charge-pump switches have virtually no offset and extremely low on-resistance
- Minimal power is consumed by the drive circuitry
- The impedances of the reservoir and pump capacitors are negligible

For the MAX680/MAX681, the energy loss per clock cycle is the sum of the energy loss in the positive and negative converters as below:

$$\begin{aligned} \text{LOSS}_{\text{TOT}} &= \text{LOSS}_{\text{POS}} + \text{LOSS}_{\text{NEG}} \\ &= \frac{1}{2} C_1 [(V_+)^2 - (V_+)(V_{\text{CC}})] + \\ &\quad \frac{1}{2} C_2 [(V_+)^2 - (V_-)^2] \end{aligned}$$

There will be a substantial voltage difference between $(V_+ - V_{\text{CC}})$ and V_{CC} for the positive pump, and between V_+ and V_- , if the impedances of pump capacitors C1 and C2 are high relative to their respective output loads.

Larger C3 and C4 reservoir capacitor values reduce output ripple. Larger values of both pump and reservoir capacitors improve efficiency.

Maximum Operating Limits

The MAX680/MAX681 have on-chip zener diodes that clamp V_{CC} to approximately 6.2V, V_+ to 12.4V, and V_- to -12.4V. Never exceed the maximum supply voltage: excessive current may be shunted by these diodes, potentially damaging the chip. The MAX680/MAX681 operate over the entire operating temperature range with an input voltage of +2V to +6V.

Applications

Positive and Negative Converter

The most common application of the MAX680/MAX681 is as a dual charge-pump voltage converter that provides positive and negative outputs of two times a positive input voltage. For applications where PC board space is at a premium, the MAX681, with its capacitors internal to the package, offers the smallest footprint. The simple circuit shown in Figure 3 performs the same function using the MAX680 with external capacitors C1 and C3 for the positive pump and C2 and C4 for the negative pump. In most applications, all four capacitors are low-cost, 10 μ F or 22 μ F polarized electrolytics. When using the MAX680 for low-current applications, 1 μ F can be used for C1 and C2 charge-pump capacitors, and 4.7 μ F for C3 and C4 reservoir capacitors. C1 and C3 must be rated at 6V or greater, and C2 and C4 must be rated at 12V or greater.

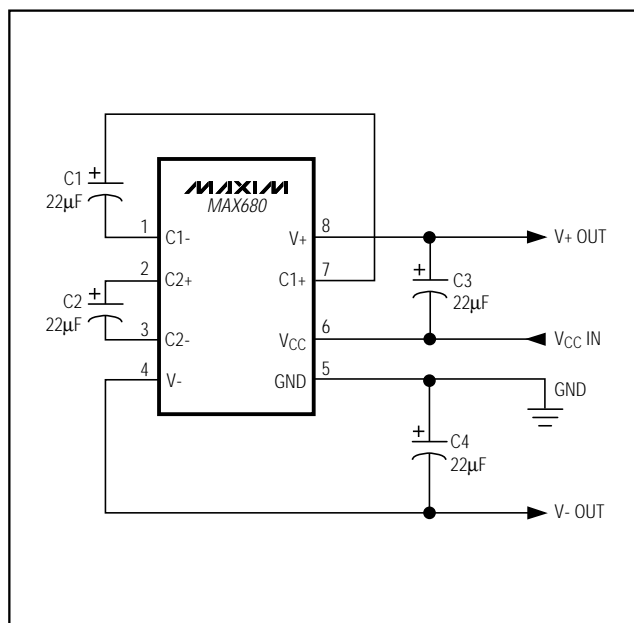

Figure 3. Positive and Negative Converter

+5V to ±10V Voltage Converters

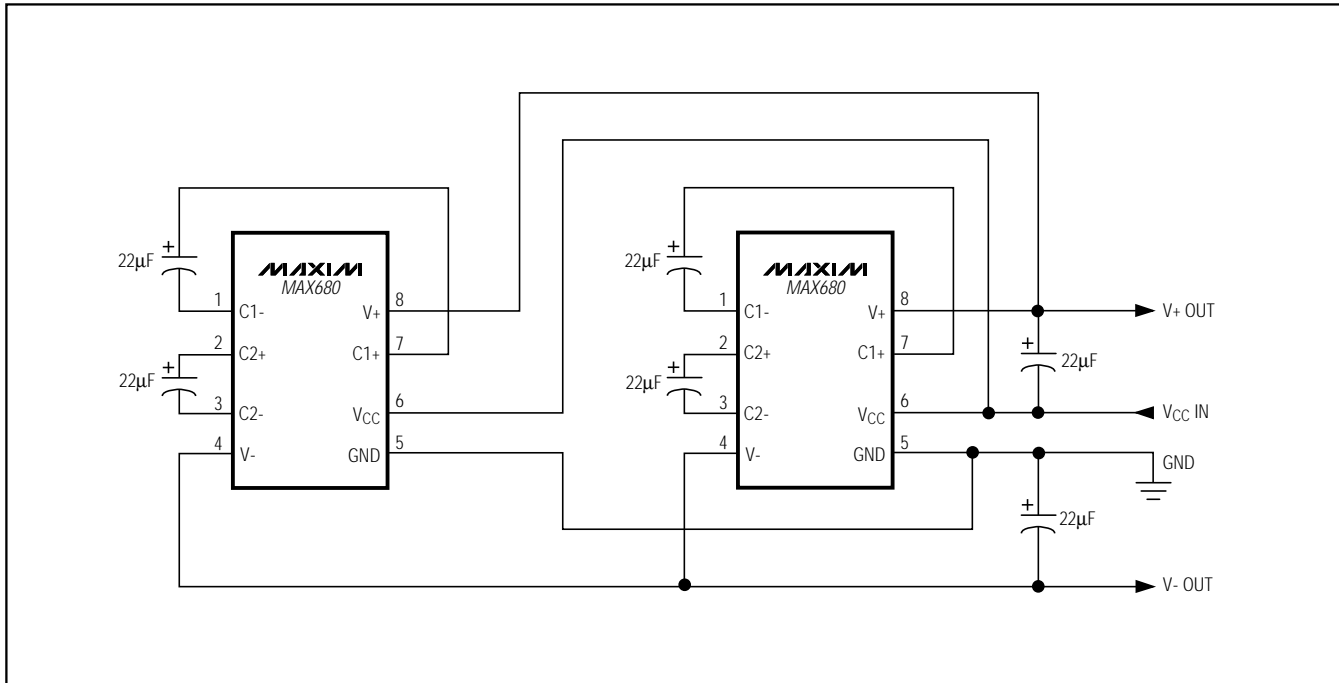

Figure 4. Paralleling MAX680s For Lower Source Resistance

The MAX680/MAX681 are **not** voltage regulators: the output source resistance of either charge pump is approximately 150Ω at room temperature with V_{CC} at 5V. Under light load with an input V_{CC} of 5V, V_+ will approach +10V and V_- will be at -10V. However **both**, V_+ and V_- will droop toward GND as the current drawn from **either** V_+ or V_- increases, since the negative converter draws its power from the positive converter's output. To predict output voltages, treat the chips as two separate converters and analyze them separately. First, the droop of the negative supply (V_{DROPN}) equals the current drawn from V_- (I_{L-}) times the source resistance of the negative converter (RS_-):

$$V_{DROPN} = I_{L-} \times RS_-$$

Likewise, the positive supply droop (V_{DROPP}) equals the current drawn from the positive supply (I_{L+}) times the positive converter's source resistance (RS_+), except that the current drawn from the positive supply is the sum of the current drawn by the load on the positive supply (I_{L+}) plus the current drawn by the negative converter (I_{L-}):

$$(V_{DROPP}) = I_{L+} \times RS_+ = (I_{L+} + I_{L-}) \times RS_+$$

The positive output voltage will be:

$$V_+ = 2V_{CC} - V_{DROPP}$$

The negative output voltage will be:

$$V_- = (V_+ - V_{DROPP}) - (2V_{CC} - V_{DROPP} - V_{DROPN})$$

The positive and negative charge pumps are tested and specified separately to provide the separate values of output source resistance for use in the above formulas. When the positive charge pump is tested, the negative charge pump is unloaded. When the negative charge pump is tested, the positive supply V_+ is from an external source, isolating the negative charge pump.

Calculate the ripple voltage on either output by noting that the current drawn from the output is supplied by the reservoir capacitor alone during one half-cycle of the clock. This results in a ripple of:

$$V_{RIPPLE} = \frac{1}{2} I_{OUT} (1/f_{PUMP})(1/CR)$$

For the nominal f_{PUMP} of 8kHz with $10\mu F$ reservoir capacitors, the ripple will be 30mV with I_{OUT} at 5mA. Remember that in most applications, the positive charge pump's I_{OUT} is the load current **plus** the current taken by the negative charge pump.

+5V to ±10V Voltage Converters

Paralleling Devices

Paralleling multiple MAX680/MAX681s reduces the output resistance of both the positive and negative converters. The effective output resistance is the output resistance of a single device divided by the number of devices. As Figure 4 shows, each MAX680 requires separate pump capacitors C1 and C2, but all can share a single set of reservoir capacitors.

±5V Regulated Supplies from a Single 3V Battery

Figure 5 shows a complete ±5V power supply using one 3V battery. The MAX680/MAX681 provide +6V at V+, which is regulated to +5V by the MAX666, and -6V, which is regulated to -5V by the MAX664. The MAX666 and MAX664 are pretrimmed at wafer sort and require

no external setting resistors, minimizing part count. The combined quiescent current of the MAX680/MAX681, MAX663, and MAX664 is less than 500µA, while the output current capability is 5mA. The MAX680/MAX681 input can vary from 3V to 6V without affecting regulation appreciably. With higher input voltage, more current can be drawn from the MAX680/MAX681 outputs. With 5V at V_{CC}, 10mA can be drawn from both regulated outputs simultaneously. Assuming 150Ω source resistance for both converters, with (I_{L+} + I_{L-}) = 20mA, the positive charge pump will droop 3V, providing +7V for the negative charge pump. The negative charge pump will droop another 1.5V due to its 10mA load, leaving -5.5V at V₋ sufficient to maintain regulation for the MAX664 at this current.

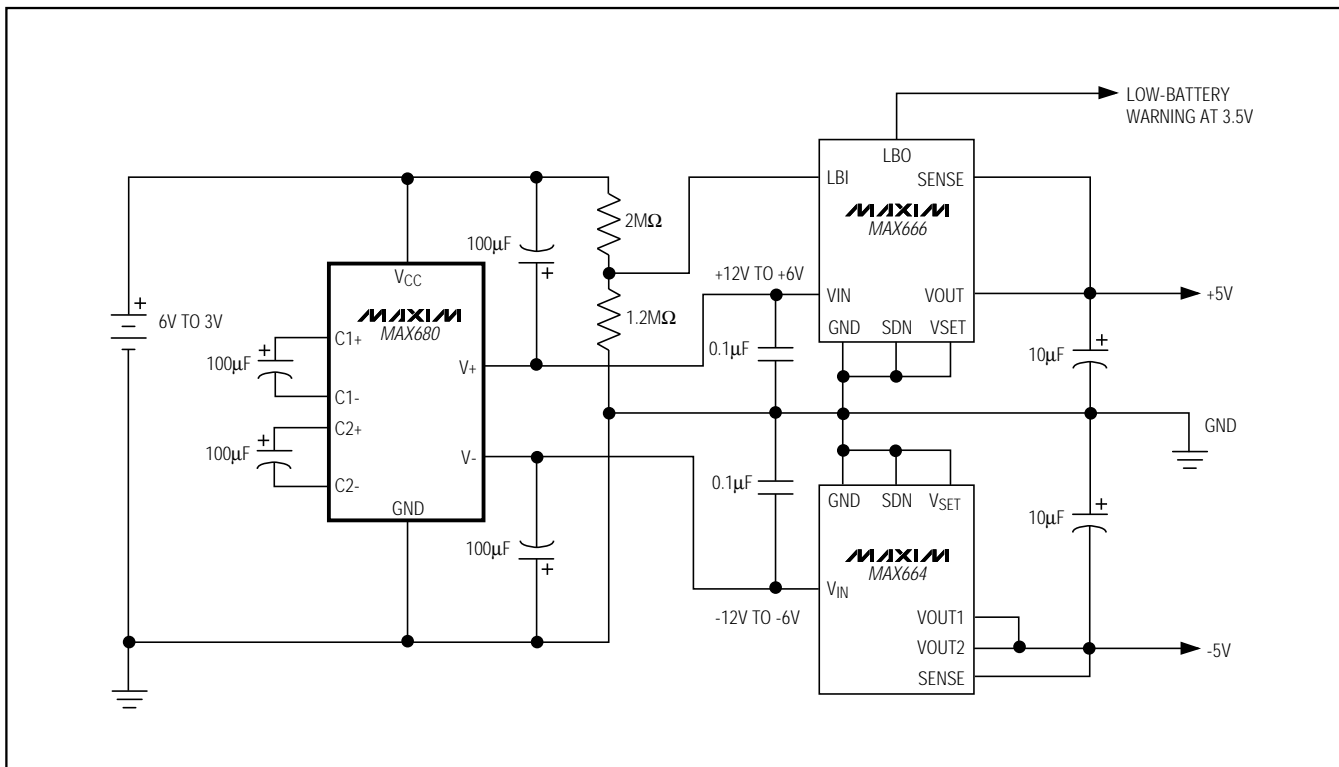
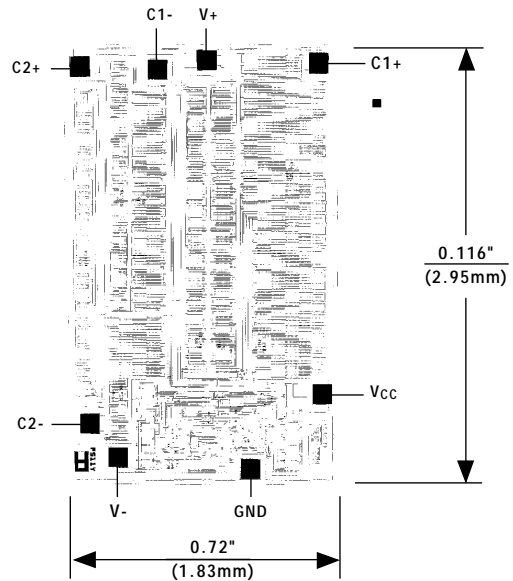

Figure 5. Regulated +5V and -5V from a Single Battery

+5V to ±10V Voltage Converters

Chip Topography



Package Information

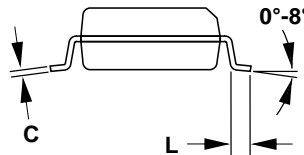
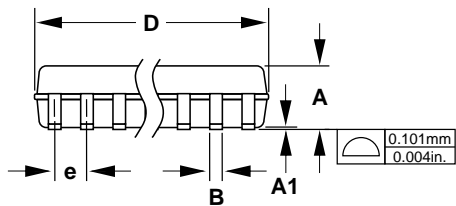

DIM	INCHES		MILLIMETERS	
	MIN	MAX	MIN	MAX
A	0.053	0.069	1.35	1.75
A1	0.004	0.010	0.10	0.25
B	0.014	0.019	0.35	0.49
C	0.007	0.010	0.19	0.25
E	0.150	0.157	3.80	4.00
e	0.050		1.27	
H	0.228	0.244	5.80	6.20
L	0.016	0.050	0.40	1.27

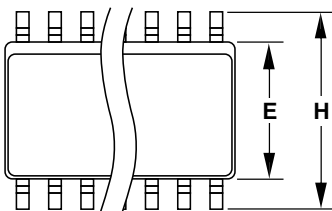

**Narrow SO
SMALL-OUTLINE
PACKAGE
(0.150 in.)**

DIM	PINS	INCHES		MILLIMETERS	
		MIN	MAX	MIN	MAX
D	8	0.189	0.197	4.80	5.00
D	14	0.337	0.344	8.55	8.75
D	16	0.386	0.394	9.80	10.00

21-0041A

Maxim cannot assume responsibility for use of any circuitry other than circuitry entirely embodied in a Maxim product. No circuit patent licenses are implied. Maxim reserves the right to change the circuitry and specifications without notice at any time.