

## Features

- Single Voltage Read/Write Operation: 2.65V to 3.6V
- Access Time – 70 ns
- Sector Erase Architecture
  - Thirty-one 32K Word (64K Bytes) Sectors with Individual Write Lockout
  - Eight 4K Word (8K Bytes) Sectors with Individual Write Lockout
- Fast Word Program Time – 12  $\mu$ s
- Fast Sector Erase Time – 300 ms
- Suspend/Resume Feature for Erase and Program
  - Supports Reading and Programming from Any Sector by Suspending Erase of a Different Sector
  - Supports Reading Any Word by Suspending Programming of Any Other Word
- Low-power Operation
  - 12 mA Active
  - 13  $\mu$ A Standby
- VPP Pin for Write Protection
- $\overline{WP}$  Pin for Sector Protection
- $\overline{RESET}$  Input for Device Initialization
- Flexible Sector Protection
- TSOP and CBGA Package Options
- Top or Bottom Boot Block Configuration Available
- 128-bit Protection Register
- Minimum 100,000 Erase Cycles
- Common Flash Interface (CFI)

## Description

The AT49BV160C(T) is a 2.7-volt 16-megabit Flash memory organized as 1,048,576 words of 16 bits each. The memory is divided into 39 sectors for erase operations. The device is offered in a 48-lead TSOP and a 46-ball CBGA package. The device has  $\overline{CE}$  and  $\overline{OE}$  control signals to avoid any bus contention. This device can be read or reprogrammed using a single power supply, making it ideally suited for in-system programming.

## Pin Configurations

| Pin Name           | Function            |
|--------------------|---------------------|
| A0 - A19           | Addresses           |
| $\overline{CE}$    | Chip Enable         |
| $\overline{OE}$    | Output Enable       |
| $\overline{WE}$    | Write Enable        |
| $\overline{RESET}$ | Reset               |
| VPP                | Write Protection    |
| I/O0 - I/O15       | Data Inputs/Outputs |
| NC                 | No Connect          |
| VCCQ               | Output Power Supply |
| $\overline{WP}$    | Write Protect       |



**16-megabit  
(1M x 16)  
3-volt Only  
Flash Memory**

**AT49BV160C  
AT49BV160CT**

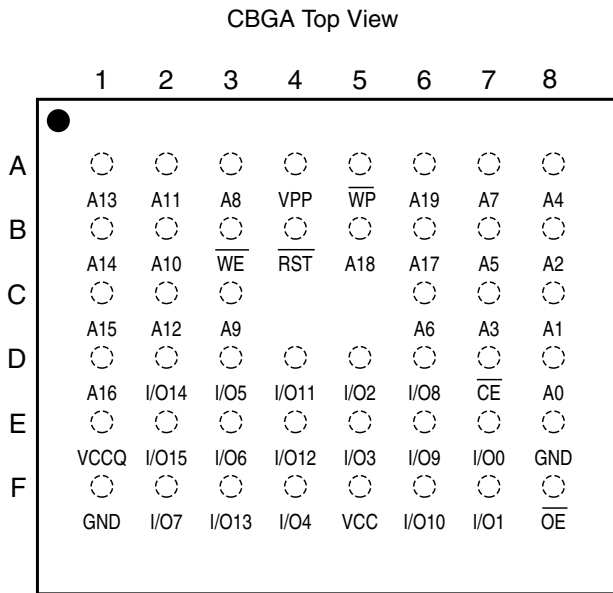
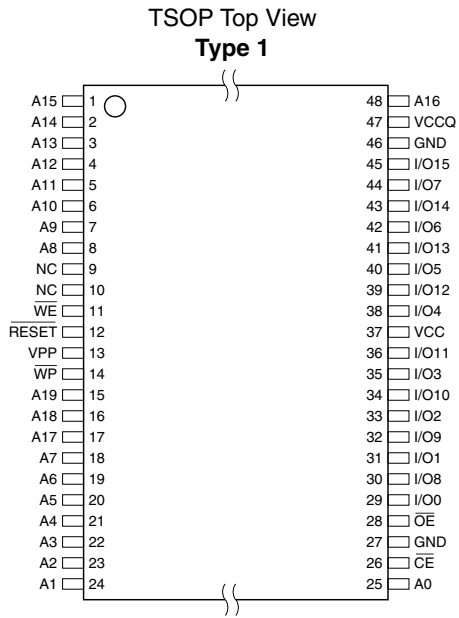

The device powers on in the read mode. Command sequences are used to place the device in other operation modes such as program and erase. The device has the capability to protect the data in any sector (see Flexible Sector Protection section).

To increase the flexibility of the device, it contains an Erase Suspend and Program Suspend feature. This feature will put the erase or program on hold for any amount of time and let the user read data from or program data to any of the remaining sectors within the memory.

The VPP pin provides data protection. When the  $V_{PP}$  input is below 0.4V, the program and erase functions are inhibited. When  $V_{PP}$  is at 1.5V or above, normal program and erase operations can be performed.

## Block Diagram

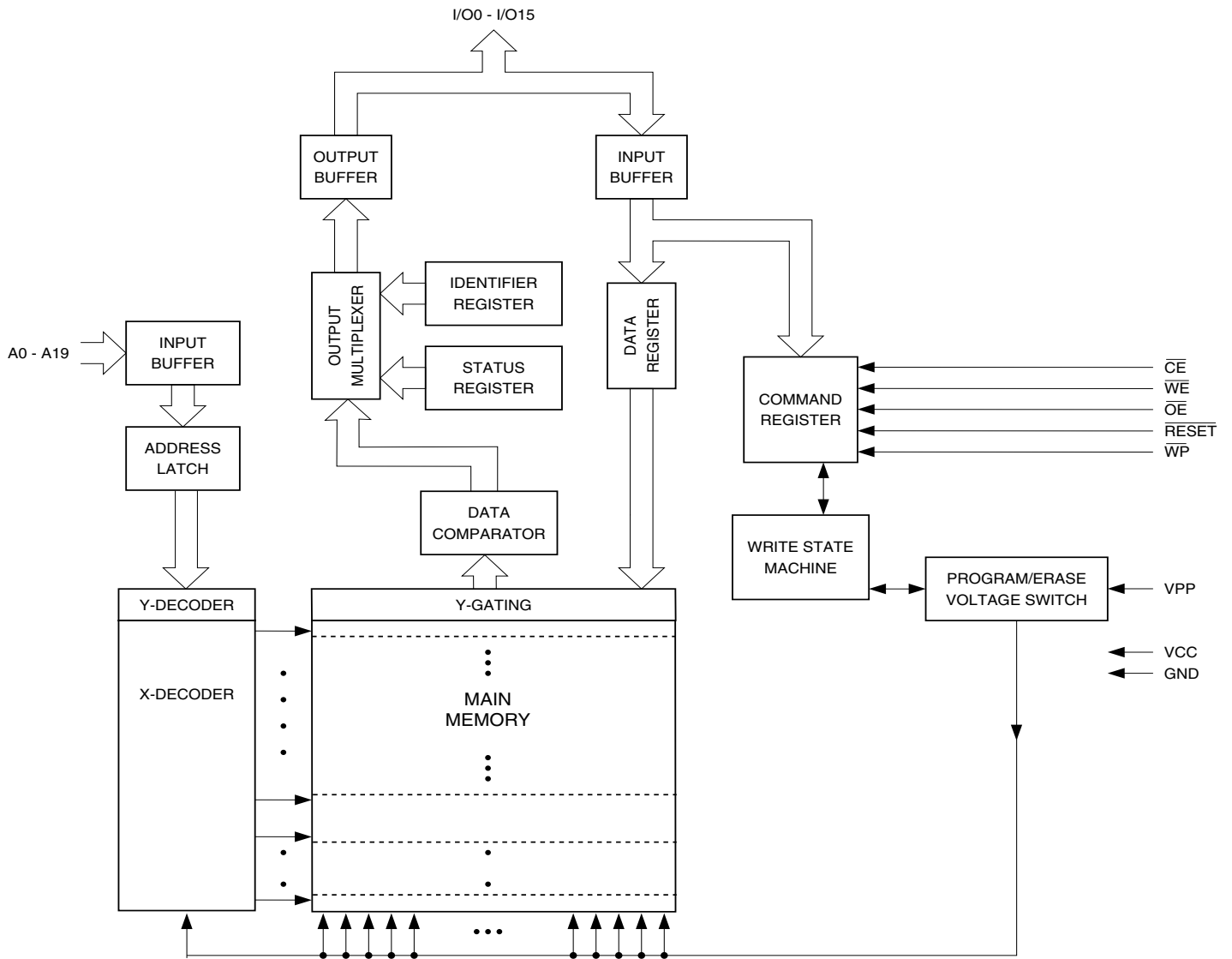



## Device Operation

**READ:** When the AT49BV160C(T) is in the read mode, with  $\overline{CE}$  and  $\overline{OE}$  low and  $\overline{WE}$  high, the data stored at the memory location determined by the address pins are asserted on the outputs. The outputs are put in the high impedance state whenever  $\overline{CE}$  or  $\overline{OE}$  is high. This dual-line control gives designers flexibility in preventing bus contention.

**COMMAND SEQUENCES:** When the device is first powered on, it will be in the read mode. In order to perform other device functions, a series of command sequences are entered into the device. The command sequences are shown in the “Command Definition” table on page 15 (I/O8 - I/O15 are don't care inputs for the command codes). The command sequences are written by applying a low pulse on the  $\overline{WE}$  or  $\overline{CE}$  input with  $\overline{CE}$  or  $\overline{WE}$  low (respectively) and  $\overline{OE}$  high. The address and data are latched by the first rising edge of  $\overline{CE}$  or  $\overline{WE}$ . Standard microprocessor write timings are used. The address locations used in the command sequences are not affected by entering the command sequences.

**RESET:** A  $\overline{RESET}$  input pin is provided to ease some system applications. When  $\overline{RESET}$  is at a logic high level, the device is in its standard operating mode. A low level on the  $\overline{RESET}$  input halts the present device operation and puts the outputs of the device in a high impedance state. When a high level is reasserted on the  $\overline{RESET}$  pin, the device returns to the read mode, depending upon the state of the control inputs.

**ERASURE:** Before a word can be reprogrammed, it must be erased. The erased state of memory bits is a logical “1”. The individual sectors can be erased by using the Sector Erase command.

**SECTOR ERASE:** The device is organized into 39 sectors (SA0 - SA38) that can be individually erased. The Sector Erase command is a two-bus cycle operation. The sector address and the D0H Data Input command are latched on the rising edge of  $\overline{WE}$ . The sector erase starts after the rising edge of  $\overline{WE}$  of the second cycle provided the given sector has not been protected. The erase operation is internally controlled; it will automatically time to completion. The maximum time to erase a sector is  $t_{SEC}$ . An attempt to erase a sector that has been protected will result in the operation terminating immediately.

**WORD PROGRAMMING:** Once a memory sector is erased, it is programmed (to a logical “0”) on a word-by-word basis. Programming is accomplished via the Internal Device command register and is a two-bus cycle operation. The device will automatically generate the required internal program pulses.

Any commands written to the chip during the embedded programming cycle will be ignored. If a hardware reset happens during programming, the data at the location being programmed will be corrupted. Please note that a data “0” cannot be programmed back to a “1”; only erase operations can convert “0”s to “1”s. Programming is completed after the specified  $t_{BP}$  cycle time. If the program status bit is a “1”, the device was not able to verify that the program operation was performed successfully. The status register indicates the programming status. While the program sequence executes, status bit I/O7 is “0”. While programming, the only valid commands are Read Status Register, Program Suspend and Program Resume.

**VPP PIN:** The circuitry of the AT49BV160C(T) is designed so that the device cannot be programmed or erased if the  $V_{PP}$  voltage is less than 0.4V. When  $V_{PP}$  is at 1.5V or above, normal program and erase operations can be performed. The VPP pin cannot be left floating.

**READ STATUS REGISTER:** The status register indicates the status of device operations and the success/failure of that operation. The Read Status Register command causes subsequent reads to output data from the status register until another command is issued. To return to reading from the memory, issue a Read command.

The status register bits are output on I/O7 - I/O0. The upper byte, I/O15 - I/O8, outputs 00H when a Read Status Register command is issued.

The contents of the status register [SR7:SR0] are latched on the falling edge of  $\overline{OE}$  or  $\overline{CE}$  (whichever occurs last), which prevents possible bus errors that might occur if status register contents change while being read.  $\overline{CE}$  or  $\overline{OE}$  must be toggled with each subsequent status read, or the status register will not indicate completion of a Program or Erase operation.

When the Write State Machine (WSM) is active, SR7 will indicate the status of the WSM; the remaining bits in the status register indicate whether the WSM was successful in performing the preferred operation (see Table 1).

**Table 1. Status Register Bit Definition**

| WSMS  | ESS | ES | PS | VPPS  | PSS | SLS | R |
|---|-----|----|----|---|-----|-----|---|
| 7   | 6   | 5  | 4  | 3   | 2   | 1   | 0 |
|   |     |    |    | <b>Notes</b>  |     |     |   |
| SR7 WRITE STATE MACHINE STATUS (WSMS)<br>1 = Ready<br>0 = Busy  |     |    |    | Check Write State Machine bit first to determine Word Program or Sector Erase completion, before checking program or erase status bits.   |     |     |   |
| SR6 = ERASE SUSPEND STATUS (ESS)<br>1 = Erase Suspended<br>0 = Erase In Progress/Completed  |     |    |    | When Erase Suspend is issued, WSM halts execution and sets both WSMS and ESS bits to "1" – ESS bit remains set to "1" until an Erase Resume command is issued.  |     |     |   |
| SR5 = ERASE STATUS (ES)<br>1 = Error in Sector Erase<br>0 = Successful Sector Erase   |     |    |    | When this bit is set to "1", WSM has applied the max number of erase pulses to the sector and is still unable to verify successful sector erasure.  |     |     |   |
| SR4 = PROGRAM STATUS (PS)<br>1 = Error in Programming<br>0 = Successful Programming   |     |    |    | When this bit is set to "1", WSM has attempted but failed to program a word   |     |     |   |
| SR3 = VPP STATUS (VPPS)<br>1 = VPP Low Detect, Operation Abort<br>0 = VPP OK  |     |    |    | The $V_{PP}$ status bit does not provide continuous indication of VPP level. The WSM interrogates $V_{PP}$ level only after the Program or Erase command sequences have been entered and informs the system if $V_{PP}$ has not been switched on. The $V_{PP}$ is also checked before the operation is verified by the WSM. |     |     |   |
| SR2 = PROGRAM SUSPEND STATUS (PSS)<br>1 = Program Suspended<br>0 = Program in Progress/Completed                                  |     |    |    | When Program Suspend is issued, WSM halts execution and sets both WSMS and PSS bits to "1". PSS bit remains set to "1" until a Program Resume command is issued.  |     |     |   |
| SR1 = SECTOR LOCK STATUS<br>1 = Prog/Erase attempted on a locked sector; Operation aborted.<br>0 = No operation to locked sectors |     |    |    | If a Program or Erase operation is attempted to one of the locked sectors, this bit is set by the WSM. The operation specified is aborted and the device is returned to read status mode.   |     |     |   |
| SR0 = RESERVED FOR FUTURE ENHANCEMENTS (R)  |     |    |    | This bit is reserved for future use and should be masked out when polling the status register.  |     |     |   |

Note: 1. A Command Sequence Error is indicated when SR1, SR3, SR4 and SR5 are set.



**CLEAR STATUS REGISTER:** The WSM can set status register bits 1 through 7 and can clear bits 2, 6 and 7; but, the WSM cannot clear status register bits 1, 3, 4 or 5. Because bits 1, 3, 4 and 5 indicate various error conditions, these bits can be cleared only through the Clear Status Register command. By allowing the system software to control the resetting of these bits, several operations may be performed (such as cumulatively programming several addresses or erasing multiple sectors in sequence) before reading the status register to determine if an error occurred during those operations. The status register should be cleared before beginning another operation. The Read command must be issued before data can be read from the memory array. The status register can also be cleared by resetting the device.

**FLEXIBLE SECTOR PROTECTION:** The AT49BV160C(T) offers two sector protection modes, the Softlock and the Hardlock. The Softlock mode is optimized as sector protection for sectors whose content changes frequently. The Hardlock protection mode is recommended for sectors whose content changes infrequently. Once either of these two modes is enabled, the contents of the selected sector is read-only and cannot be erased or programmed. Each sector can be independently programmed for either the Softlock or Hardlock sector protection mode. At power-up and reset, all sectors have their Softlock protection mode enabled.

**SOFTLOCK AND UNLOCK:** The Softlock protection mode can be disabled by issuing a two-bus cycle Unlock command to the selected sector. Once a sector is unlocked, its contents can be erased or programmed. To enable the Softlock protection mode, a two-bus cycle Softlock command must be issued to the selected sector.

**HARDLOCK AND WRITE PROTECT:** The Hardlock sector protection mode operates in conjunction with the Write Protect ( $\overline{WP}$ ) pin. The Hardlock sector protection mode can be enabled by issuing a two-bus cycle Hardlock Software command to the selected sector. The state of the Write Protect pin affects whether the Hardlock protection mode can be overridden.

- When the  $\overline{WP}$  pin is low and the Hardlock protection mode is enabled, the sector cannot be unlocked and the contents of the sector is read-only.
- When the  $\overline{WP}$  pin is high, the Hardlock protection mode is overridden and the sector can be unlocked via the Unlock command.

To disable the Hardlock sector protection mode, the chip must be either reset or power cycled.

**Table 2.** Hardlock and Softlock Protection Configurations in Conjunction with  $\overline{WP}$

| $V_{PP}$    | $\overline{WP}$ | Hard-lock | Soft-lock | Erase/<br>Prog<br>Allowed? | Comments  |
|-------------|-----------------|-----------|-----------|----------------------------|---|
| $V_{CC}/5V$ | 0               | 0         | 0         | Yes                        | No sector is locked   |
| $V_{CC}/5V$ | 0               | 0         | 1         | No                         | Sector is Softlocked. The Unlock command can unlock the sector.                               |
| $V_{CC}/5V$ | 0               | 1         | 1         | No                         | Hardlock protection mode is enabled. The sector cannot be unlocked.                           |
| $V_{CC}/5V$ | 1               | 0         | 0         | Yes                        | No sector is locked.  |
| $V_{CC}/5V$ | 1               | 0         | 1         | No                         | Sector is Softlocked. The Unlock command can unlock the sector.                               |
| $V_{CC}/5V$ | 1               | 1         | 0         | Yes                        | Hardlock protection mode is overridden and the sector is not locked.                          |
| $V_{CC}/5V$ | 1               | 1         | 1         | No                         | Hardlock protection mode is overridden and the sector can be unlocked via the Unlock command. |
| $V_{IL}$    | x               | x         | x         | No                         | Erase and Program Operations cannot be performed.   |

**Figure 1.** Sector Locking State Diagram

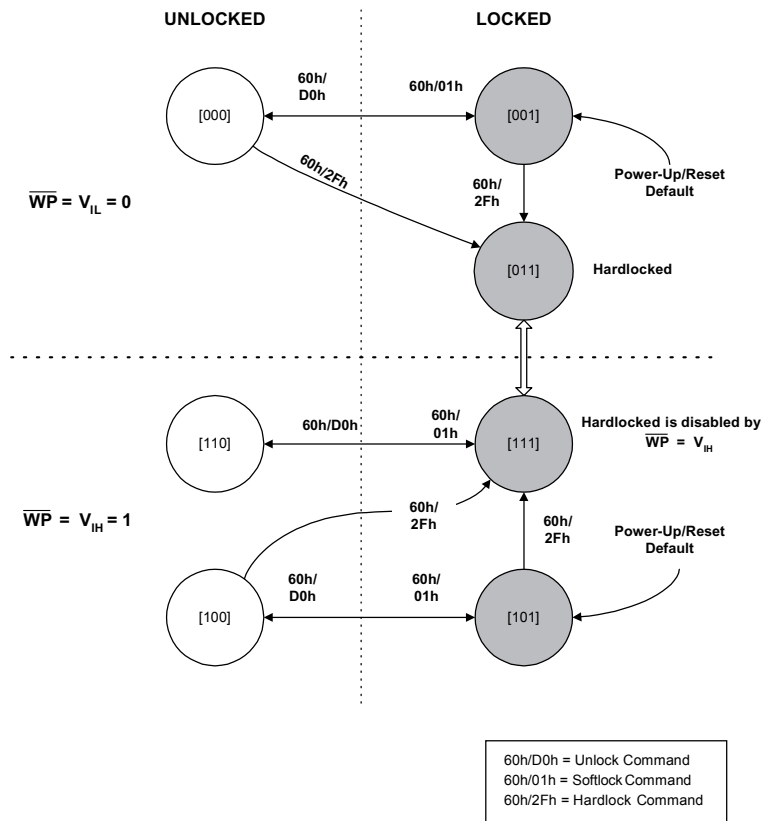

Notes: 1. The notation [X, Y, Z] denotes the locking state of a sector. The current locking state of a sector is defined by the state of  $\overline{WP}$  and the two bits of the sector-lock status D[1:0].



**SECTOR PROTECTION DETECTION:** A software method is available to determine if the sector protection Softlock or Hardlock features are enabled. When the device is in the software product identification mode, a read from the I/O0 and I/O1 at address location 00002H within a sector will show if the sector is unlocked, softlocked, or hardlocked.

**Table 3.** Sector Protection Status

| I/O1 | I/O0 | Sector Protection Status           |
|------|------|------------------------------------|
| 0    | 0    | Sector Not Locked                  |
| 0    | 1    | Softlock Enabled                   |
| 1    | 0    | Hardlock Enabled                   |
| 1    | 1    | Both Hardlock and Softlock Enabled |

**ERASE SUSPEND/ERASE RESUME:** The Erase Suspend command allows the system to interrupt a sector erase operation and then program or read data from a different sector within the memory. After the Erase Suspend command is given, the device requires a maximum time of 15  $\mu$ s to suspend the erase operation. After the erase operation has been suspended, the system can then read data or program data to any other sector within the device. An address is not required during the Erase Suspend command. During a sector erase suspend, another sector cannot be erased. To resume the sector erase operation, the system must write the Erase Resume command. The Erase Resume command is a one-bus cycle command. The only valid commands while erase is suspended are Read Status Register, Product ID Entry, CFI Query, Program, Program Resume, Erase Resume, Sector Softlock/Hardlock, Sector Unlock.

**PROGRAM SUSPEND/PROGRAM RESUME:** The Program Suspend command allows the system to interrupt a programming operation and then read data from a different word within the memory. After the Program Suspend command is given, the device requires a maximum of 20  $\mu$ s to suspend the programming operation. After the programming operation has been suspended, the system can then read data from any other word within the device. An address is not required during the program suspend operation. To resume the programming operation, the system must write the Program Resume command. The program suspend and resume are one-bus cycle commands. The command sequence for the erase suspend and program suspend are the same and the command sequence for the erase resume and program resume are the same. The only other valid commands while program is suspended are Read Status Register, Product ID Entry, CFI Query and Program Resume.

**PRODUCT IDENTIFICATION:** The product identification mode identifies the device and manufacturer as Atmel. It may be accessed a software operation. For details, see “Operating Modes” on page 19.

**128-BIT PROTECTION REGISTER:** The AT49BV160C(T) contains a 128-bit register that can be used for security purposes in system design. The protection register is divided into two 64-bit sectors. The two sectors are designated as sector A and sector B. The data in sector A is non-changeable and is programmed at the factory with a unique number. The data in sector B is programmed by the user and can be locked out such that data in the sector cannot be reprogrammed. To program sector B in the protection register, the two-bus cycle Program Protection Register command must be used as shown in the “Command Definition” table on page 15. To lock out sector B, the two-bus cycle Lock Protection Register command must be used as shown in the “Command Definition” table. Data bit D1 must be zero during the second bus cycle. All other data bits during the second bus cycle are don’t cares. To determine whether sector B is locked out, use the status of sector B protection command. If data bit D1 is zero, sector B is locked. If data bit D1 is one, sector B can be reprogrammed. Please see the “Protection Register Addressing Table” on page 16 for the address locations in the protection



register. To read the protection register, the Product ID Entry command is given followed by a normal read operation from an address within the protection register. After determining whether sector B is protected or not, or reading the protection register, the Read command must be given to return to the read mode.

**CFI:** Common Flash Interface (CFI) is a published, standardized data structure that may be read from a flash device. CFI allows system software to query the installed device to determine the configurations, various electrical and timing parameters and functions supported by the device. CFI is used to allow the system to learn how to interface to the flash device most optimally. The two primary benefits of using CFI are ease of upgrading and second source availability. The command to enter the CFI Query mode is a one-bus cycle command which requires writing data 98h to any address. The CFI Query command can be written when the device is ready to read data or can also be written when the part is in the product ID mode. Once in the CFI Query mode, the system can read CFI data at the addresses given in Table 4 on page 25. To return to the read mode, issue the Read command.

**HARDWARE DATA PROTECTION:** The Hardware Data Protection feature protects against inadvertent programs to the AT49BV160C(T) in the following ways: (a)  $V_{CC}$  sense: if  $V_{CC}$  is below 1.8V (typical), the program function is inhibited. (b)  $V_{CC}$  power-on delay: once  $V_{CC}$  has reached the  $V_{CC}$  sense level, the device will automatically time out 10 ms (typical) before programming. (c) Program inhibit: holding any one of  $\overline{OE}$  low,  $\overline{CE}$  high or  $\overline{WE}$  high inhibits program cycles. (d) Program inhibit:  $V_{PP}$  is less than  $V_{ILPP}$ . (e)  $V_{PP}$  power-on delay: once  $V_{PP}$  has reached 0.9V, program and erase operations are inhibited for 100 ns.

**INPUT LEVELS:** While operating with a 2.65V to 3.6V power supply, the address inputs and control inputs ( $\overline{OE}$ ,  $\overline{CE}$  and  $\overline{WE}$ ) may be driven from 0 to 5.5V without adversely affecting the operation of the device. The I/O lines can only be driven from 0 to  $V_{CCQ} + 0.6V$ .

**OUTPUT LEVELS:** For the AT49BV160C(T), output high levels ( $V_{OH}$ ) are equal to  $V_{CCQ} - 0.1V$  (not  $V_{CC}$ ). For 2.65V - 3.6V output levels,  $V_{CCQ}$  must be tied to  $V_{CC}$ . For 1.8V - 2.2V output levels,  $V_{CCQ}$  must be regulated to  $2.0V \pm 10\%$ , while  $V_{CC}$  must be regulated to 2.65V - 3.0V (for minimum power).

### Word Program Flowchart

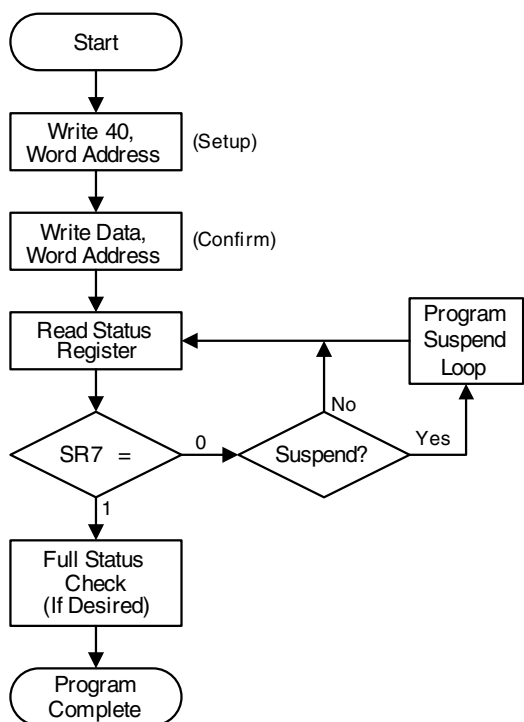

### Word Program Procedure

| Bus Operation | Command       | Comments  |
|---------------|---------------|---|
| Write         | Program Setup | Data = 40<br>Addr = Location to program   |
| Write         | Data          | Data = Data to program<br>Addr = Location to program                                      |
| Read          | None          | Status register data: Toggle $\overline{CE}$ or $\overline{OE}$ to update status register |
| Idle          | None          | Check SR7<br>1 = WSM Ready<br>0 = WSM Busy  |

Repeat for subsequent Word Program operations.  
Full status register check can be done after each program, or after a sequence of program operations.  
Write FF after the last operation to set to the Read state.

### Full Status Check Flowchart

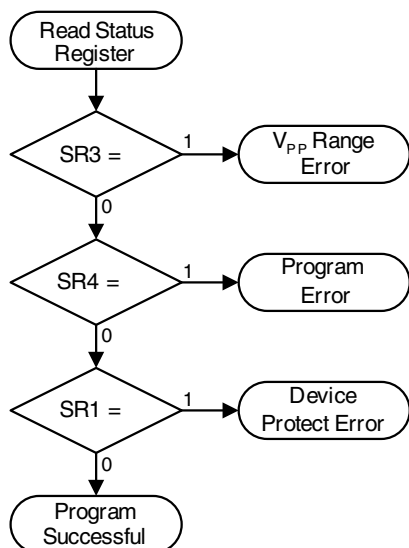

### Full Status Check Procedure

| Bus Operation | Command | Comments   |
|---------------|---------|--|
| Idle          | None    | Check SR3:<br>1 = $V_{PP}$ Error                   |
| Idle          | None    | Check SR4:<br>1 = Data Program Error               |
| Idle          | None    | Check SR1:<br>1 = Sector locked; operation aborted |

SR3 MUST be cleared before the Write State Machine allows further program attempts.  
If an error is detected, clear the status register before continuing operations – only the Clear Status Register command clears the status register error bits.

## Program Suspend/Resume Flowchart

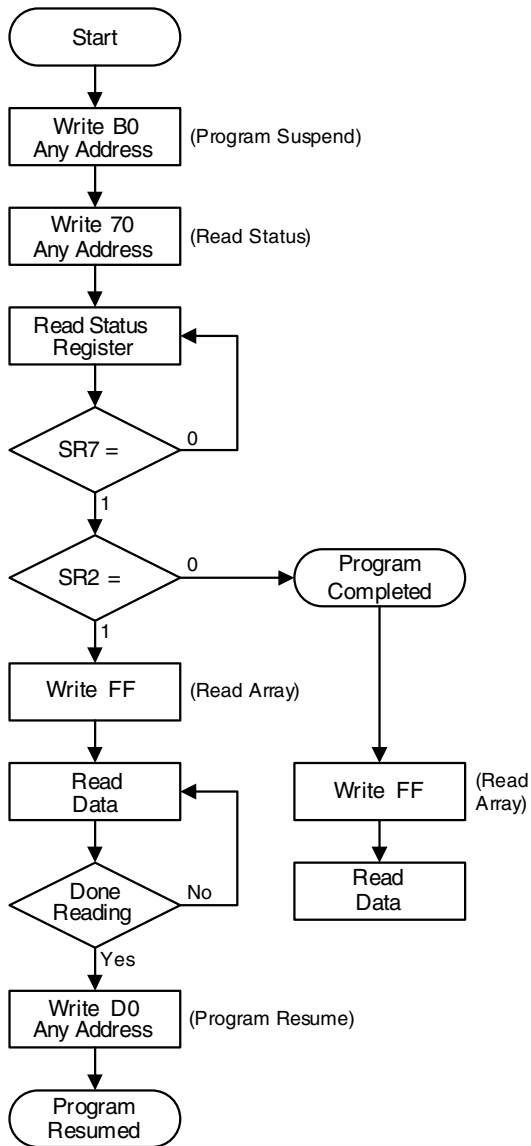

## Program Suspend/Resume Procedure

| Bus Operation | Command         | Comments  |
|---------------|-----------------|---|
| Write         | Read Status     | Data = 70<br>Addr = Any address   |
| Write         | Program Suspend | Data = B0<br>Addr = Any address   |
| Read          | None            | Status register data: Toggle $\overline{CE}$ or $\overline{OE}$ to update status register<br>Addr = Any address |
| Idle          | None            | Check SR7<br>1 = WSM Ready<br>0 = WSM Busy  |
| Idle          | None            | Check SR2<br>1 = Program suspended<br>0 = Program completed   |
| Write         | Read Array      | Data = FF<br>Addr = Any address   |
| Read          | None            | Read data from any word in the memory   |
| Write         | Program Resume  | Data = D0<br>Addr = Any address   |

### Erase Suspend/Resume Flowchart

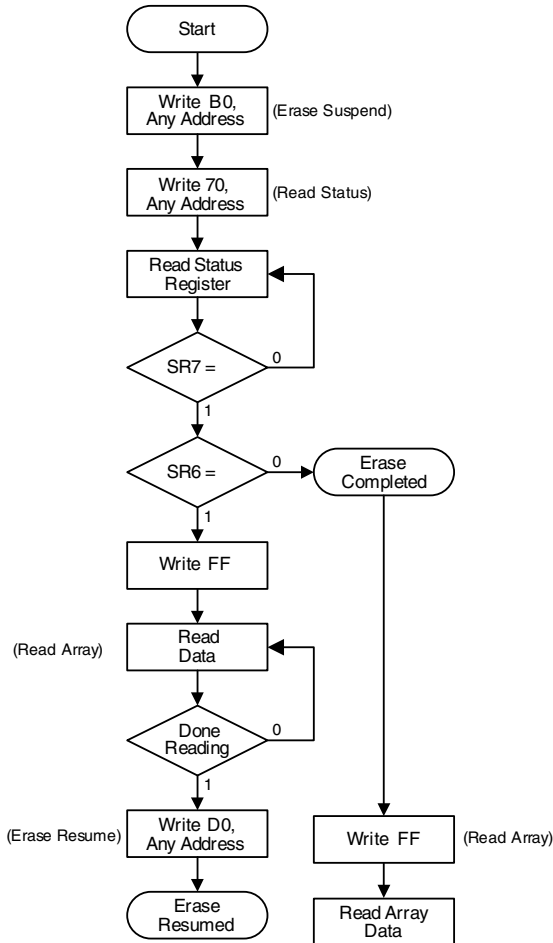

### Erase Suspend/Resume Procedure

| Bus Operation | Command         | Comments  |
|---------------|-----------------|---|
| Write         | Read Status     | Data = 70<br>Addr = Any address   |
| Write         | Erase Suspend   | Data = B0<br>Addr = Any address   |
| Read          | None            | Status register data: Toggle $\overline{CE}$ or $\overline{OE}$ to update status register<br>Addr = Any address |
| Idle          | None            | Check SR7<br>1 = WSM Ready<br>0 = WSM Busy  |
| Idle          | None            | Check SR6<br>1 = Erase suspended<br>0 = Erase completed   |
| Write         | Read or Program | Data = FF or 40<br>Addr = Any address   |
| Read or Write | None            | Read or program data from/to sector other than the one being erased   |
| Write         | Program Resume  | Data = D0<br>Addr = Any address   |

## Sector Erase Flowchart

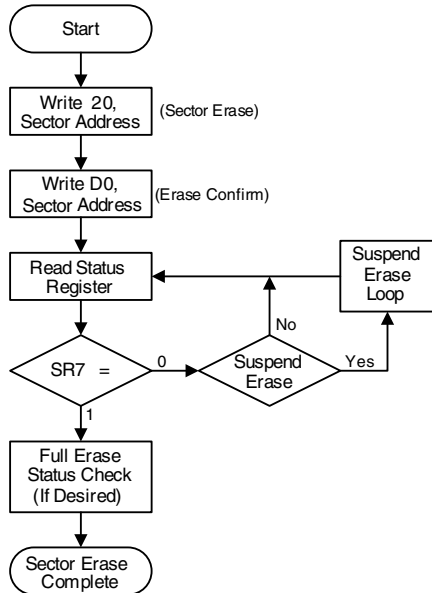

## Sector Erase Procedure

| Bus Operation | Command            | Comments   |
|---------------|--------------------|--|
| Write         | Sector Erase Setup | Data = 20<br>Addr = Sector to be erased (SA)   |
| Write         | Erase Confirm      | Data = D0<br>Addr = Sector to be erased (SA)   |
| Read          | None               | Status register data: Toggle $\overline{CE}$ or $\overline{OE}$ to update status register data |
| Idle          | None               | Check SR7<br>1 = WSM Ready<br>0 = WSM Busy   |

Repeat for subsequent sector erasures.  
Full status register check can be done after each sector erase, or after a sequence of sector erasures.  
Write FF after the last operation to enter read mode.

## Full Erase Status Check Flowchart

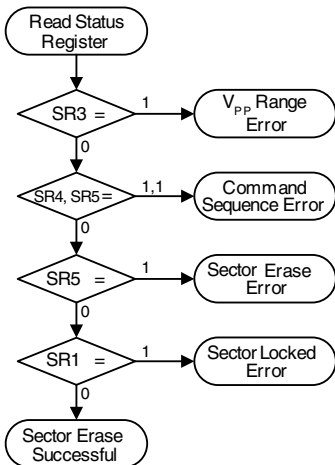

## Full Erase Status Check Procedure

| Bus Operation | Command | Comments  |
|---------------|---------|---|
| Idle          | None    | Check SR3:<br>1 = $V_{PP}$ Range Error                                |
| Idle          | None    | Check SR4, SR5:<br>Both 1 = Command Sequence Error                    |
| Idle          | None    | Check SR5:<br>1 = Sector Erase Error                                  |
| Idle          | None    | Check SR1:<br>1 = Attempted erase of locked sector;<br>erase aborted. |

SR1, SR3 must be cleared before the Write State Machine allows further erase attempts.  
Only the Clear Status Register command clears SR1, SR3, SR4, SR5.  
If an error is detected, clear the status register before attempting an erase retry or other error recovery.

## Protection Register Programming Flowchart

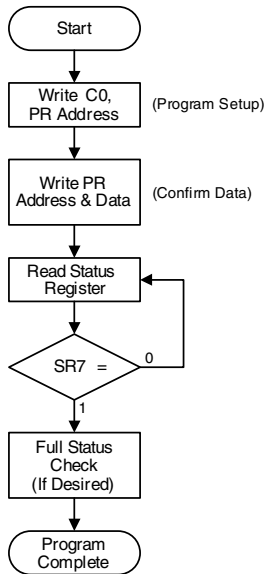

## Protection Register Programming Procedure

| Bus Operation | Command            | Comments   |
|---------------|--------------------|--|
| Write         | Program PR Setup   | Data = C0<br>Addr = First Location to Program  |
| Write         | Protection Program | Data = Data to Program<br>Addr = Location to Program   |
| Read          | None               | Status register data: Toggle $\overline{CE}$ or $\overline{OE}$ to update status register data |
| Idle          | None               | Check SR7<br>1 = WSM Ready<br>0 = WSM Busy   |

Program Protection Register operation addresses must be within the protection register address space. Addresses outside this space will return an error.

Repeat for subsequent programming operations.

Full status register check can be done after each program, or after a sequence of program operations.

Write FF after the last operation to return to the Read mode.

## Full Status Check Flowchart

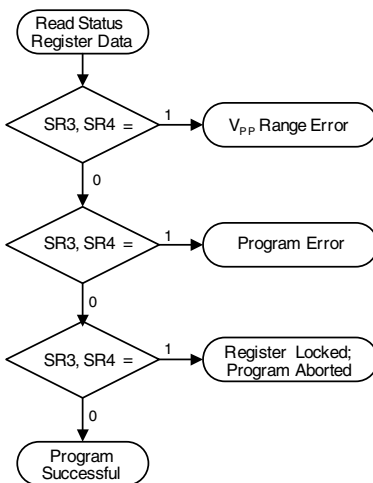

## Full Status Check Procedure

| Bus Operation | Command | Comments  |
|---------------|---------|---|
| Idle          | None    | Check SR1, SR3, SR4:<br>0,1,1 = $V_{PP}$ Range Error              |
| Idle          | None    | Check SR1, SR3, SR4:<br>0,0,1 = Programming Error                 |
| Idle          | None    | Check SR1, SR3, SR4:<br>1, 0,1 = Sector locked; operation aborted |

SR3 must be cleared before the Write State Machine allows further program attempts.

Only the Clear Status Register command clears SR1, SR3, SR4.

If an error is detected, clear the status register before attempting a program retry or other error recovery.

## Command Definition in Hex<sup>(1)</sup>

| Command Sequence                    | Bus Cycles | 1st Bus Cycle |       | 2nd Bus Cycle     |                                 |
|-------------------------------------|------------|---------------|-------|-------------------|---------------------------------|
|                                     |            | Addr          | Data  | Addr              | Data                            |
| Read                                | 1          | XX            | FF    |                   |                                 |
| Sector Erase/Confirm                | 2          | XX            | 20    | SA <sup>(2)</sup> | D0                              |
| Word Program                        | 2          | XX            | 40/10 | Addr              | D <sub>IN</sub>                 |
| Erase/Program Suspend               | 1          | XX            | B0    |                   |                                 |
| Erase/Program Resume                | 1          | XX            | D0    |                   |                                 |
| Product ID Entry                    | 1          | XX            | 90    |                   |                                 |
| Sector Softlock                     | 2          | XX            | 60    | SA <sup>(2)</sup> | 01                              |
| Sector Hardlock                     | 2          | XX            | 60    | SA <sup>(2)</sup> | 2F                              |
| Sector Unlock                       | 2          | XX            | 60    | SA <sup>(2)</sup> | D0                              |
| Read Status Register                | 2          | XX            | 70    | XX                | D <sub>OUT</sub> <sup>(3)</sup> |
| Clear Status Register               | 1          | XX            | 50    |                   |                                 |
| Program Protection Register         | 2          | XX            | C0    | Addr              | D <sub>IN</sub>                 |
| Lock Protection Register – Sector B | 2          | XX            | C0    | 80                | FFFD                            |
| Status of Sector B Protection       | 2          | XX            | 90    | 80                | D <sub>OUT</sub> <sup>(4)</sup> |
| CFI Query                           | 1          | XX            | 98    |                   |                                 |

Notes: 1. The DATA FORMAT shown for each bus cycle is as follows; I/O7 - I/O0 (Hex). I/O15 - I/O8 are don't care. The ADDRESS FORMAT shown for each bus cycle is as follows: A7 - A0 (Hex). Address A19 through A8 are don't care.

2. SA = sector address. Any word address within a sector can be used to designate the sector address (see pages 17 and 18 for details).

3. The status register bits are output on I/O7 - I/O0.

4. If data bit D1 is "0", sector B is locked. If data bit D1 is "1", sector B can be reprogrammed.

## Absolute Maximum Ratings\*

|   |                                 |
|---|---------------------------------|
| Temperature under Bias .....  | -55°C to +125°C                 |
| Storage Temperature .....   | -65°C to +150°C                 |
| All Input Voltages<br>(including NC Pins)<br>with Respect to Ground ..... | -0.6V to +6.25V                 |
| All Output Voltages<br>with Respect to Ground .....                       | -0.6V to V <sub>CC</sub> + 0.6V |
| Voltage on V <sub>PP</sub><br>with Respect to Ground .....                | -0.6V to +13.0V                 |

\*NOTICE: Stresses beyond those listed under "Absolute Maximum Ratings" may cause permanent damage to the device. This is a stress rating only and functional operation of the device at these or any other conditions beyond those indicated in the operational sections of this specification is not implied. Exposure to absolute maximum rating conditions for extended periods may affect device reliability.



## Protection Register Addressing Table

| Word | Use     | Sector | A7 | A6 | A5 | A4 | A3 | A2 | A1 | A0 |
|------|---------|--------|----|----|----|----|----|----|----|----|
| 0    | Factory | A      | 1  | 0  | 0  | 0  | 0  | 0  | 0  | 1  |
| 1    | Factory | A      | 1  | 0  | 0  | 0  | 0  | 0  | 1  | 0  |
| 2    | Factory | A      | 1  | 0  | 0  | 0  | 0  | 0  | 1  | 1  |
| 3    | Factory | A      | 1  | 0  | 0  | 0  | 0  | 1  | 0  | 0  |
| 4    | User    | B      | 1  | 0  | 0  | 0  | 0  | 1  | 0  | 1  |
| 5    | User    | B      | 1  | 0  | 0  | 0  | 0  | 1  | 1  | 0  |
| 6    | User    | B      | 1  | 0  | 0  | 0  | 0  | 1  | 1  | 1  |
| 7    | User    | B      | 1  | 0  | 0  | 0  | 1  | 0  | 0  | 0  |

Note: All address lines not specified in the above table must be "0" when accessing the protection register, i.e., A19 - A8 = 0.



## AT49BV160C – Sector Address Table

| Sector | Size (Bytes/Words) | Address Range (A19 - A0) |
|--------|--------------------|--------------------------|
| SA0    | 8K/4K              | 00000 - 00FFF            |
| SA1    | 8K/4K              | 01000 - 01FFF            |
| SA2    | 8K/4K              | 02000 - 02FFF            |
| SA3    | 8K/4K              | 03000 - 03FFF            |
| SA4    | 8K/4K              | 04000 - 04FFF            |
| SA5    | 8K/4K              | 05000 - 05FFF            |
| SA6    | 8K/4K              | 06000 - 06FFF            |
| SA7    | 8K/4K              | 07000 - 07FFF            |
| SA8    | 64K/32K            | 08000 - 0FFFF            |
| SA9    | 64K/32K            | 10000 - 17FFF            |
| SA10   | 64K/32K            | 18000 - 1FFFF            |
| SA11   | 64K/32K            | 20000 - 27FFF            |
| SA12   | 64K/32K            | 28000 - 2FFFF            |
| SA13   | 64K/32K            | 30000 - 37FFF            |
| SA14   | 64K/32K            | 38000 - 3FFFF            |
| SA15   | 64K/32K            | 40000 - 47FFF            |
| SA16   | 64K/32K            | 48000 - 4FFFF            |
| SA17   | 64K/32K            | 50000 - 57FFF            |
| SA18   | 64K/32K            | 58000 - 5FFFF            |
| SA19   | 64K/32K            | 60000 - 67FFF            |
| SA20   | 64K/32K            | 68000 - 6FFFF            |
| SA21   | 64K/32K            | 70000 - 77FFF            |
| SA22   | 64K/32K            | 78000 - 7FFFF            |
| SA23   | 64K/32K            | 80000 - 87FFF            |
| SA24   | 64K/32K            | 88000 - 8FFFF            |
| SA25   | 64K/32K            | 90000 - 97FFF            |
| SA26   | 64K/32K            | 98000 - 9FFFF            |
| SA27   | 64K/32K            | A0000 - A7FFF            |
| SA28   | 64K/32K            | A8000 - AFFFF            |
| SA29   | 64K/32K            | B0000 - B7FFF            |
| SA30   | 64K/32K            | B8000 - BFFFF            |
| SA31   | 64K/32K            | C0000 - C7FFF            |
| SA32   | 64K/32K            | C8000 - CFFFF            |
| SA33   | 64K/32K            | D0000 - D7FFF            |
| SA34   | 64K/32K            | D8000 - DFFFF            |
| SA35   | 64K/32K            | E0000 - E7FFF            |
| SA36   | 64K/32K            | E8000 - EFFFF            |
| SA37   | 64K/32K            | F0000 - F7FFF            |
| SA38   | 64K/32K            | F8000 - FFFFF            |



## AT49BV160CT – Sector Address Table

| Sector | Size (Bytes/Words) | x16<br>Address Range (A19 - A0) |
|--------|--------------------|---------------------------------|
| SA0    | 64K/32K            | 00000 - 07FFF                   |
| SA1    | 64K/32K            | 08000 - 0FFFF                   |
| SA2    | 64K/32K            | 10000 - 17FFF                   |
| SA3    | 64K/32K            | 18000 - 1FFFF                   |
| SA4    | 64K/32K            | 20000 - 27FFF                   |
| SA5    | 64K/32K            | 28000 - 2FFFF                   |
| SA6    | 64K/32K            | 30000 - 37FFF                   |
| SA7    | 64K/32K            | 38000 - 3FFFF                   |
| SA8    | 64K/32K            | 40000 - 47FFF                   |
| SA9    | 64K/32K            | 48000 - 4FFFF                   |
| SA10   | 64K/32K            | 50000 - 57FFF                   |
| SA11   | 64K/32K            | 58000 - 5FFFF                   |
| SA12   | 64K/32K            | 60000 - 67FFF                   |
| SA13   | 64K/32K            | 68000 - 6FFFF                   |
| SA14   | 64K/32K            | 70000 - 77FFF                   |
| SA15   | 64K/32K            | 78000 - 7FFFF                   |
| SA16   | 64K/32K            | 80000 - 87FFF                   |
| SA17   | 64K/32K            | 88000 - 8FFFF                   |
| SA18   | 64K/32K            | 90000 - 97FFF                   |
| SA19   | 64K/32K            | 98000 - 9FFFF                   |
| SA20   | 64K/32K            | A0000 - A7FFF                   |
| SA21   | 64K/32K            | A8000 - AFFFF                   |
| SA22   | 64K/32K            | B0000 - B7FFF                   |
| SA23   | 64K/32K            | B8000 - BFFFF                   |
| SA24   | 64K/32K            | C0000 - C7FFF                   |
| SA25   | 64K/32K            | C8000 - CFFFF                   |
| SA26   | 64K/32K            | D0000 - D7FFF                   |
| SA27   | 64K/32K            | D8000 - DFFFF                   |
| SA28   | 64K/32K            | E0000 - E7FFF                   |
| SA29   | 64K/32K            | E8000 - EFFFF                   |
| SA30   | 64K/32K            | F0000 - F7FFF                   |
| SA31   | 8K/4K              | F8000 - F8FFF                   |
| SA32   | 8K/4K              | F9000 - F9FFF                   |
| SA33   | 8K/4K              | FA000 - FAFFF                   |
| SA34   | 8K/4K              | FB000 - FBFFF                   |
| SA35   | 8K/4K              | FC000 - FCFFF                   |
| SA36   | 8K/4K              | FD000 - FDFFF                   |
| SA37   | 8K/4K              | FE000 - FEFFF                   |
| SA38   | 8K/4K              | FF000 - FFFFF                   |

## DC and AC Operating Range

|                              |      | AT49BV160C(T)-70 |
|------------------------------|------|------------------|
| Operating Temperature (Case) | Ind. | -40°C - 85°C     |
| V <sub>CC</sub> Power Supply |      | 2.65V to 3.6V    |

## Operating Modes

| Mode                            | $\overline{CE}$ | $\overline{OE}$  | $\overline{WE}$ | $\overline{RESET}$ | V <sub>PP</sub>                  | Ai  | I/O                              |
|---------------------------------|-----------------|------------------|-----------------|--------------------|----------------------------------|---|----------------------------------|
| Read                            | V <sub>IL</sub> | V <sub>IL</sub>  | V <sub>IH</sub> | V <sub>IH</sub>    | X                                | Ai  | D <sub>OUT</sub>                 |
| Program/Erase <sup>(2)</sup>    | V <sub>IL</sub> | V <sub>IH</sub>  | V <sub>IL</sub> | V <sub>IH</sub>    | V <sub>IHPP</sub> <sup>(5)</sup> | Ai  | D <sub>IN</sub>                  |
| Standby/Program Inhibit         | V <sub>IH</sub> | X <sup>(1)</sup> | X               | V <sub>IH</sub>    | X                                | X   | High-Z                           |
| Program Inhibit                 | X               | X                | V <sub>IH</sub> | V <sub>IH</sub>    | X                                |   |                                  |
|                                 | X               | V <sub>IL</sub>  | X               | V <sub>IH</sub>    | X                                |   |                                  |
|                                 | X               | X                | X               | V <sub>IH</sub>    | V <sub>ILPP</sub> <sup>(6)</sup> |   |                                  |
| Output Disable                  | X               | V <sub>IH</sub>  | X               | V <sub>IH</sub>    | X                                |   | High-Z                           |
| Reset                           | X               | X                | X               | V <sub>IL</sub>    | X                                | X   | High-Z                           |
| Product Identification Software |                 |                  |                 | V <sub>IH</sub>    |                                  | A0 = V <sub>IL</sub> , A1 - A19 = V <sub>IL</sub> | Manufacturer Code <sup>(4)</sup> |
|                                 |                 |                  |                 |                    |                                  | A0 = V <sub>IH</sub> , A1 - A19 = V <sub>IL</sub> | Device Code <sup>(4)</sup>       |

- Notes:
1. X can be V<sub>IL</sub> or V<sub>IH</sub>.
  2. Refer to AC programming waveforms on page 24.
  3. V<sub>H</sub> = 12.0V ± 0.5V.
  4. Manufacturer Code: 001FH, Device Code: 88C3H – AT49BV160C; 88C2H – AT49BV160CT
  5. V<sub>IHPP</sub> (min) = 0.9V; V<sub>IHPP</sub> (max) = 1.95V.
  6. V<sub>ILPP</sub> (max) = 0.4V.



## DC Characteristics

| Symbol         | Parameter                     | Condition  | Min             | Typ | Max  | Units   |
|----------------|-------------------------------|--|-----------------|-----|------|---------|
| $I_{LI}$       | Input Load Current            | $V_{IN} = 0V \text{ to } V_{CC}$                   |                 |     | 10   | $\mu A$ |
| $I_{LO}$       | Output Leakage Current        | $V_{I/O} = 0V \text{ to } V_{CC}$                  |                 |     | 10   | $\mu A$ |
| $I_{SB}$       | $V_{CC}$ Standby Current CMOS | $\overline{CE} = V_{CC} - 0.3V \text{ to } V_{CC}$ |                 | 13  | 25   | $\mu A$ |
| $I_{CC}^{(1)}$ | $V_{CC}$ Active Read Current  | $f = 5 \text{ MHz}; I_{OUT} = 0 \text{ mA}$        |                 | 12  | 25   | mA      |
| $I_{CC1}$      | $V_{CC}$ Programming Current  |  |                 |     | 45   | mA      |
| $I_{PP1}$      | $V_{PP}$ Input Load Current   |  |                 |     | 10   | $\mu A$ |
| $V_{IL}$       | Input Low Voltage             |  |                 |     | 0.4  | V       |
| $V_{IH}$       | Input High Voltage            |  | $V_{CCQ} - 0.2$ |     |      | V       |
| $V_{OL}$       | Output Low Voltage            | $I_{OL} = 100 \mu A$                               |                 |     | 0.10 | V       |
| $V_{OH}$       | Output High Voltage           | $I_{OH} = -100 \mu A$                              | $V_{CCQ} - 0.1$ |     |      | V       |

Note: 1. In the erase mode,  $I_{CC}$  is 65 mA.

## AC Read Characteristics

| Symbol            | Parameter   | AT49BV160C(T)-70 |     | Units |
|-------------------|---|------------------|-----|-------|
|                   |   | Min              | Max |       |
| $t_{RC}$          | Read Cycle Time   | 70               |     | ns    |
| $t_{ACC}$         | Address to Output Delay   |                  | 70  | ns    |
| $t_{CE}^{(1)}$    | $\overline{CE}$ to Output Delay   |                  | 70  | ns    |
| $t_{OE}^{(2)}$    | $\overline{OE}$ to Output Delay   | 0                | 20  | ns    |
| $t_{DF}^{(3)(4)}$ | $\overline{CE}$ or $\overline{OE}$ to Output Float                                      | 0                | 25  | ns    |
| $t_{OH}$          | Output Hold from $\overline{OE}$ , $\overline{CE}$ or Address, whichever occurred first | 0                |     | ns    |
| $t_{RO}$          | $\overline{RESET}$ to Output Delay  |                  | 100 | ns    |

## AC Read Waveforms<sup>(1)(2)(3)(4)</sup>

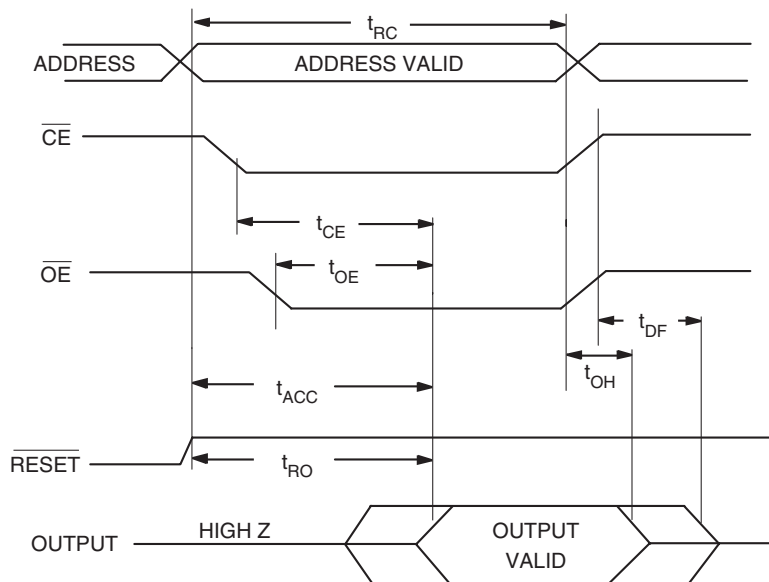

- Notes:
- $\overline{CE}$  may be delayed up to  $t_{ACC} - t_{CE}$  after the address transition without impact on  $t_{ACC}$ .
  - $\overline{OE}$  may be delayed up to  $t_{CE} - t_{OE}$  after the falling edge of  $\overline{CE}$  without impact on  $t_{CE}$  or by  $t_{ACC} - t_{OE}$  after an address change without impact on  $t_{ACC}$ .
  - $t_{DF}$  is specified from  $\overline{OE}$  or  $\overline{CE}$ , whichever occurs first (CL = 5 pF).
  - This parameter is characterized and is not 100% tested.

## Input Test Waveforms and Measurement Level

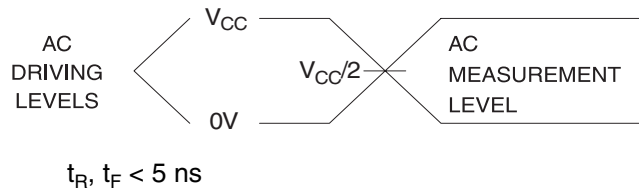

## Output Test Load

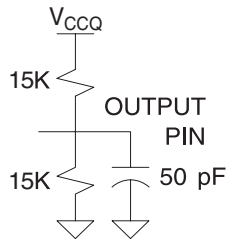

## Pin Capacitance

$f = 1 \text{ MHz}, T = 25^\circ\text{C}^{(1)}$

| Symbol    | Typ | Max | Units | Conditions     |
|-----------|-----|-----|-------|----------------|
| $C_{IN}$  | 4   | 6   | pF    | $V_{IN} = 0V$  |
| $C_{OUT}$ | 8   | 12  | pF    | $V_{OUT} = 0V$ |

Note: This parameter is characterized and is not 100% tested.

## AC Word Load Characteristics

| Symbol            | Parameter  | Min | Max | Units |
|-------------------|--|-----|-----|-------|
| $t_{AS}, t_{OES}$ | Address, $\overline{OE}$ Setup Time                      | 45  |     | ns    |
| $t_{AH}$          | Address Hold Time  | 0   |     | ns    |
| $t_{CS}$          | Chip Select Setup Time                                   | 0   |     | ns    |
| $t_{CH}$          | Chip Select Hold Time                                    | 0   |     | ns    |
| $t_{WP}$          | Write Pulse Width ( $\overline{WE}$ or $\overline{CE}$ ) | 40  |     | ns    |
| $t_{DS}$          | Data Setup Time  | 45  |     | ns    |
| $t_{DH}, t_{OEH}$ | Data, $\overline{OE}$ Hold Time                          | 0   |     | ns    |
| $t_{WPH}$         | Write Pulse Width High                                   | 30  |     | ns    |

## AC Word Load Waveforms

### $\overline{WE}$ Controlled

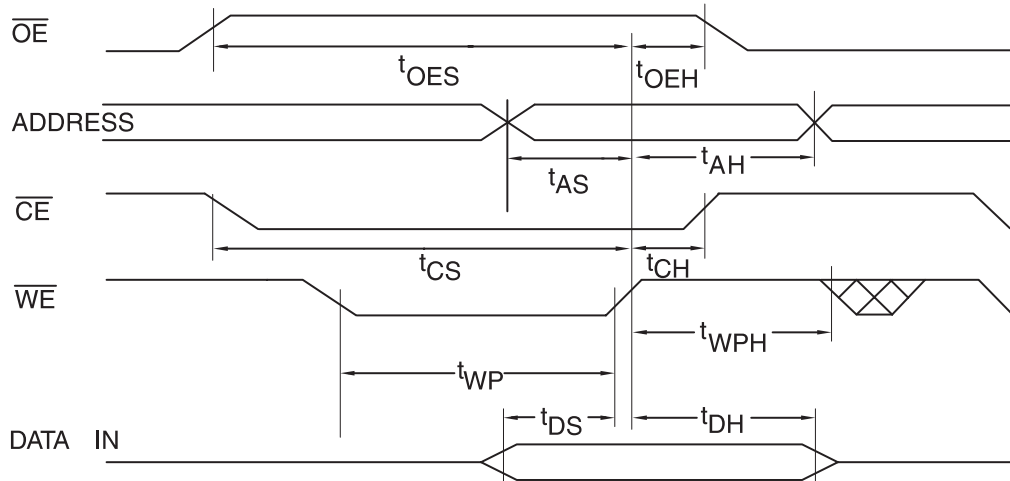

### $\overline{CE}$ Controlled

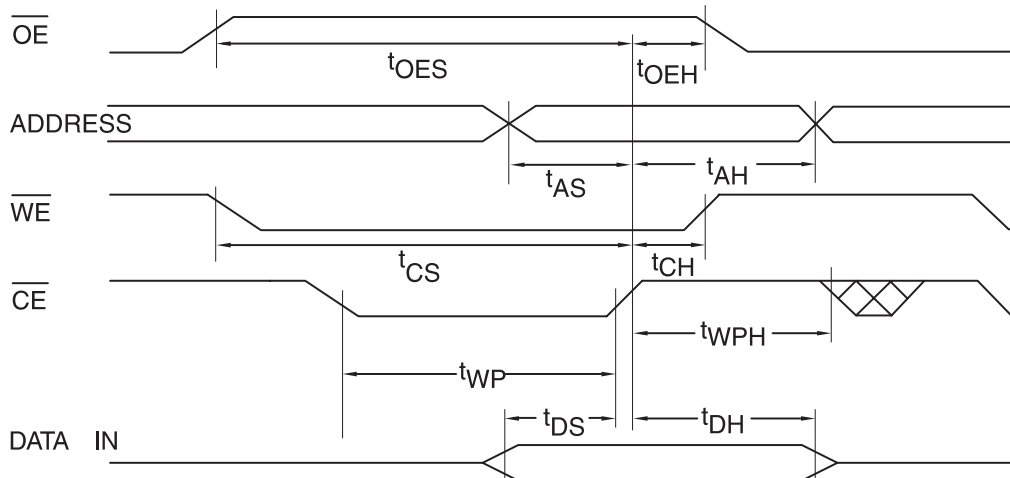



## Program Cycle Characteristics

| Symbol     | Parameter                                  | Min | Typ | Max | Units         |
|------------|--|-----|-----|-----|---------------|
| $t_{BP}$   | Word Programming Time                      |     | 12  | 120 | $\mu\text{s}$ |
| $t_{AS}$   | Address Setup Time                         | 45  |     |     | ns            |
| $t_{AH}$   | Address Hold Time                          | 0   |     |     | ns            |
| $t_{DS}$   | Data Setup Time                            | 45  |     |     | ns            |
| $t_{DH}$   | Data Hold Time                             | 0   |     |     | ns            |
| $t_{WP}$   | Write Pulse Width                          | 40  |     |     | ns            |
| $t_{WPH}$  | Write Pulse Width High                     | 30  |     |     | ns            |
| $t_{WC}$   | Write Cycle Time                           | 70  |     |     | ns            |
| $t_{RP}$   | Reset Pulse Width                          | 500 |     |     | ns            |
| $t_{SEC1}$ | Sector Erase Cycle Time (4K Word Sectors)  |     | 0.3 | 3.0 | seconds       |
| $t_{SEC2}$ | Sector Erase Cycle Time (32K Word Sectors) |     | 0.8 | 6.0 | seconds       |
| $t_{ES}$   | Erase Suspend Time                         |     |     | 15  | $\mu\text{s}$ |
| $t_{PS}$   | Program Suspend Time                       |     |     | 20  | $\mu\text{s}$ |

## Program Cycle Waveforms

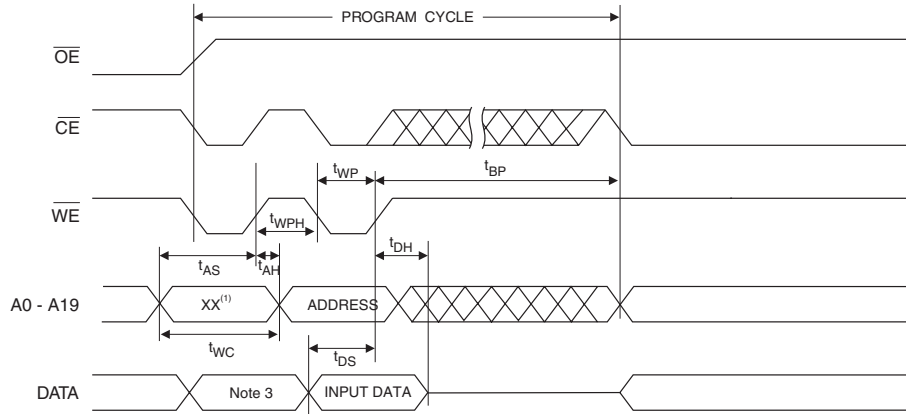

## Sector Erase Cycle Waveforms

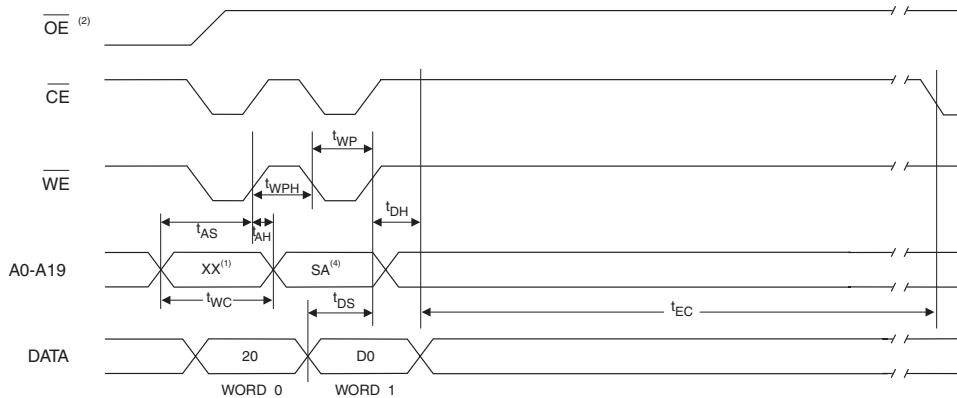

- Notes:
1. Any address can be used to load the data.
  2.  $\overline{OE}$  must be high only when  $\overline{WE}$  and  $\overline{CE}$  are both low.
  3. The data can be 40H or 10H.
  4. The address depends on what sector is to be erased.



**Table 4.** Common Flash Interface Definition

| Address | AT49BV160CT | AT49BV160C |   |
|---------|-------------|------------|---|
| 10h     | 0051h       | 0051h      | “Q”   |
| 11h     | 0052h       | 0052h      | “R”   |
| 12h     | 0059h       | 0059h      | “Y”   |
| 13h     | 0003h       | 0003h      |   |
| 14h     | 0000h       | 0000h      |   |
| 15h     | 0041h       | 0041h      |   |
| 16h     | 0000h       | 0000h      |   |
| 17h     | 0000h       | 0000h      |   |
| 18h     | 0000h       | 0000h      |   |
| 19h     | 0000h       | 0000h      |   |
| 1Ah     | 0000h       | 0000h      |   |
| 1Bh     | 0027h       | 0027h      | VCC min write/erase                                 |
| 1Ch     | 0036h       | 0036h      | VCC max write/erase                                 |
| 1Dh     | 00B5h       | 00B5h      | VPP min voltage                                     |
| 1Eh     | 00C5h       | 00C5h      | VPP max voltage                                     |
| 1Fh     | 0004h       | 0004h      | Typ word write – 12 $\mu$ s                         |
| 20h     | 0000h       | 0000h      |   |
| 21h     | 000Ah       | 000Ah      | Typ sector erase, 1,000 ms                          |
| 22h     | 0000h       | 0000h      | Typ chip erase, not supported                       |
| 23h     | 0003h       | 0003h      | Max word write/typ time                             |
| 24h     | 0000h       | 0000h      | n/a   |
| 25h     | 0003h       | 0003h      | Max sector erase/typ sector erase                   |
| 26h     | 0000h       | 0000h      | Max chip erase/ typ chip erase                      |
| 27h     | 0015h       | 0015h      | Device size   |
| 28h     | 0001h       | 0001h      | x16 device  |
| 29h     | 0000h       | 0000h      | x16 device  |
| 2Ah     | 0000h       | 0000h      | Multiple byte write not supported                   |
| 2Bh     | 0000h       | 0000h      | Multiple byte write not supported                   |
| 2Ch     | 0002h       | 0002h      | 2 regions, x = 2                                    |
| 2Dh     | 001Eh       | 0007h      | 64K bytes, Y = 30 (Top); 8K bytes, Y = 7 (Bottom)   |
| 2Eh     | 0000h       | 0000h      | 64K bytes, Y = 30 (Top); 8K bytes, Y = 7 (Bottom)   |
| 2Fh     | 0000h       | 0020h      | 64K bytes, Z = 256 (Top); 8K bytes, Z = 32 (Bottom) |
| 30h     | 0001h       | 0000h      | 64K bytes, Z = 256 (Top); 8K bytes, Z = 32 (Bottom) |
| 31h     | 0007h       | 001Eh      | 8K bytes, Y = 7 (Top); 64K bytes, Y = 30 (Bottom)   |
| 32h     | 0000h       | 0000h      | 8K bytes, Y = 7 (Top); 64K bytes, Y = 30 (Bottom)   |
| 33h     | 0020h       | 0000h      | 8K bytes, Z = 32 (Top); 64K bytes, Z = 256 (Bottom) |
| 34h     | 0000h       | 0001h      | 8K bytes, Z = 32 (Top); 64K bytes, Z = 256 (Bottom) |



**Table 4.** Common Flash Interface Definition (Continued)

| Address                               | AT49BV160CT | AT49BV160C |  |
|---------------------------------------|-------------|------------|--|
| <b>VENDOR SPECIFIC EXTENDED QUERY</b> |             |            |  |
| 41h                                   | 0050h       | 0050h      | “P”  |
| 42h                                   | 0052h       | 0052h      | “R”  |
| 43h                                   | 0049h       | 0049h      | “I”  |
| 44h                                   | 0031h       | 0031h      | Major version number, ASCII  |
| 45h                                   | 0030h       | 0030h      | Minor version number, ASCII  |
| 46h                                   | 0086h       | 0086h      | Bit 0 – chip erase supported, 0 – no, 1 – yes<br>Bit 1 – erase suspend supported, 0 – no, 1 – yes<br>Bit 2 – program suspend supported, 0 – no, 1 – yes<br>Bit 3 – simultaneous operations supported,<br>0 – no, 1 – yes<br>Bit 4 – burst mode read supported, 0 – no, 1 – yes<br>Bit 5 – page mode read supported, 0 – no, 1 – yes<br>Bit 6 – queued erase supported, 0 – no, 1 – yes<br>Bit 7 – protection bits supported, 0 – no, 1 – yes |
| 47h                                   | 0000h       | 0001h      | Bit 8 – top (“0”) or bottom (“1”) boot sector device undefined bits are “0”  |
| 48h                                   | 0000h       | 0000h      | Bit 0 – 4 word linear burst with wrap around,<br>0 – no, 1 – yes<br>Bit 1 – 8 word linear burst with wrap around,<br>0 – no, 1 – yes<br>Bit 2 – continuous burst, 0 - no, 1 - yes<br>Undefined bits are “0”  |
| 49h                                   | 0000h       | 0000h      | Bit 0 – 4 word page, 0 – no, 1 – yes<br>Bit 1 – 8 word page, 0 – no, 1 – yes<br>Undefined bits are “0”   |
| 4Ah                                   | 0080h       | 0080h      | Location of protection register lock byte, the<br>section’s first byte   |
| 4Bh                                   | 0003h       | 0003h      | # of bytes in the factory prog section of prot<br>register – 2*n   |
| 4Ch                                   | 0003h       | 0003h      | # of bytes in the user prog section of prot<br>register – 2*n  |

## AT49BV160C(T) Ordering Information

| t <sub>ACC</sub><br>(ns) | I <sub>CC</sub> (mA) |         | Ordering Code    | Package | Operation Range               |
|--------------------------|----------------------|---------|------------------|---------|-------------------------------|
|                          | Active               | Standby |                  |         |                               |
| 70                       | 25                   | 0.025   | AT49BV160C-70CI  | 46C3    | Industrial<br>(-40° to 85° C) |
|                          |                      |         | AT49BV160C-70TI  | 48T     |                               |
| 70                       | 25                   | 0.025   | AT49BV160CT-70CI | 46C3    | Industrial<br>(-40° to 85° C) |
|                          |                      |         | AT49BV160CT-70TI | 48T     |                               |

| Package Type |   |
|--------------|---|
| <b>46C3</b>  | 46-ball, Plastic Chip-Size Ball Grid Array Package (CBGA) |
| <b>48T</b>   | 48-lead, Plastic Thin Small Outline Package (TSOP)        |



# Packaging Information

## 46C3 – CBGA

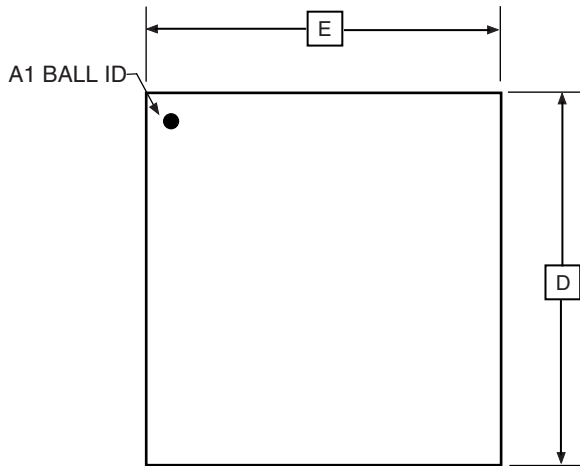

TOP VIEW

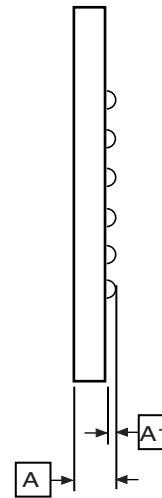

SIDE VIEW

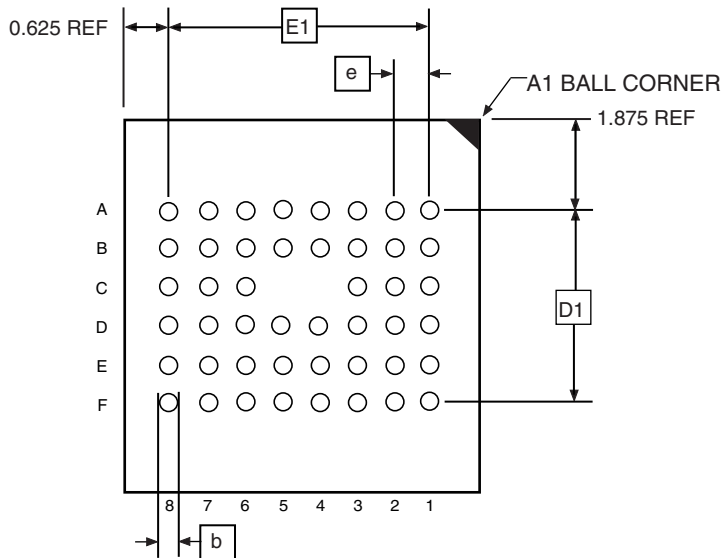

BOTTOM VIEW

COMMON DIMENSIONS  
(Unit of Measure = mm)

| SYMBOL | MIN      | NOM  | MAX  | NOTE |
|--------|----------|------|------|------|
| E      | 6.40     | 6.50 | 6.60 |      |
| E1     | 5.25 TYP |      |      |      |
| D      | 7.40     | 7.50 | 7.60 |      |
| D1     | 3.75 TYP |      |      |      |
| A      | -        | -    | 1.00 |      |
| A1     | 0.22     | -    | -    |      |
| e      | 0.75 BSC |      |      |      |
| b      | 0.35 TYP |      |      |      |

7/2/03



2325 Orchard Parkway  
San Jose, CA 95131

**TITLE**

**46C3**, 46-ball (8 x 6 Array), 0.75 mm Pitch, 6.5 x 7.5 x 1.0 mm  
Chip-scale Ball Grid Array Package (CBGA)

**DRAWING NO.**

46C3

**REV.**

A

## 48T – TSOP

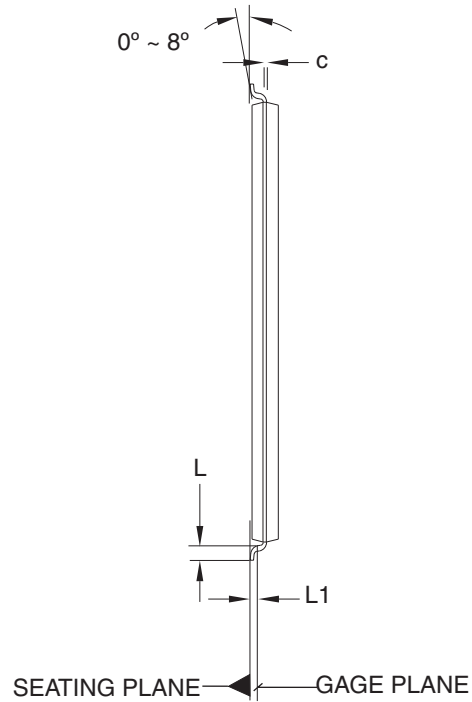
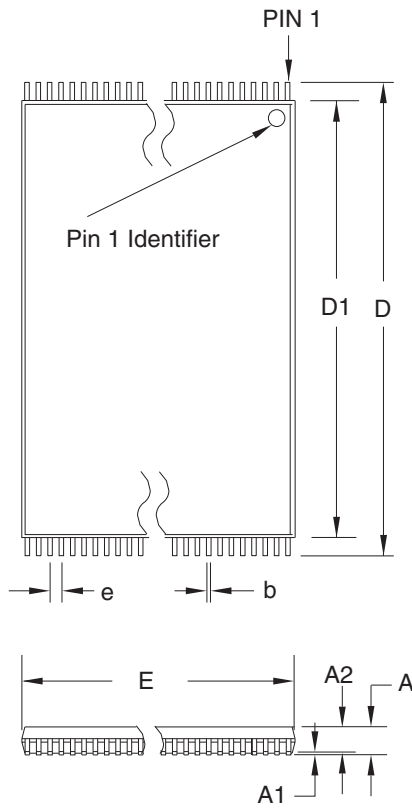

**COMMON DIMENSIONS**  
(Unit of Measure = mm)

| SYMBOL | MIN        | NOM   | MAX   | NOTE   |
|--------|------------|-------|-------|--------|
| A      | –          | –     | 1.20  |        |
| A1     | 0.05       | –     | 0.15  |        |
| A2     | 0.95       | 1.00  | 1.05  |        |
| D      | 19.80      | 20.00 | 20.20 |        |
| D1     | 18.30      | 18.40 | 18.50 | Note 2 |
| E      | 11.90      | 12.00 | 12.10 | Note 2 |
| L      | 0.50       | 0.60  | 0.70  |        |
| L1     | 0.25 BASIC |       |       |        |
| b      | 0.17       | 0.22  | 0.27  |        |
| c      | 0.10       | –     | 0.21  |        |
| e      | 0.50 BASIC |       |       |        |

- Notes:
1. This package conforms to JEDEC reference MO-142, Variation DD.
  2. Dimensions D1 and E do not include mold protrusion. Allowable protrusion on E is 0.15 mm per side and on D1 is 0.25 mm per side.
  3. Lead coplanarity is 0.10 mm maximum.

10/18/01



2325 Orchard Parkway  
San Jose, CA 95131

**TITLE**

**48T**, 48-lead (12 x 20 mm Package) Plastic Thin Small Outline Package, Type I (TSOP)

**DRAWING NO.**

48T

**REV.**

B



## Atmel Corporation

2325 Orchard Parkway  
San Jose, CA 95131, USA  
Tel: 1(408) 441-0311  
Fax: 1(408) 487-2600

## Regional Headquarters

### Europe

Atmel Sarl  
Route des Arsenaux 41  
Case Postale 80  
CH-1705 Fribourg  
Switzerland  
Tel: (41) 26-426-5555  
Fax: (41) 26-426-5500

### Asia

Room 1219  
Chinachem Golden Plaza  
77 Mody Road Tsimshatsui  
East Kowloon  
Hong Kong  
Tel: (852) 2721-9778  
Fax: (852) 2722-1369

### Japan

9F, Tonetsu Shinkawa Bldg.  
1-24-8 Shinkawa  
Chuo-ku, Tokyo 104-0033  
Japan  
Tel: (81) 3-3523-3551  
Fax: (81) 3-3523-7581

## Atmel Operations

### Memory

2325 Orchard Parkway  
San Jose, CA 95131, USA  
Tel: 1(408) 441-0311  
Fax: 1(408) 436-4314

### Microcontrollers

2325 Orchard Parkway  
San Jose, CA 95131, USA  
Tel: 1(408) 441-0311  
Fax: 1(408) 436-4314

La Chantrerie  
BP 70602  
44306 Nantes Cedex 3, France  
Tel: (33) 2-40-18-18-18  
Fax: (33) 2-40-18-19-60

### ASIC/ASSP/Smart Cards

Zone Industrielle  
13106 Rousset Cedex, France  
Tel: (33) 4-42-53-60-00  
Fax: (33) 4-42-53-60-01

1150 East Cheyenne Mtn. Blvd.  
Colorado Springs, CO 80906, USA  
Tel: 1(719) 576-3300  
Fax: 1(719) 540-1759

Scottish Enterprise Technology Park  
Maxwell Building  
East Kilbride G75 0QR, Scotland  
Tel: (44) 1355-803-000  
Fax: (44) 1355-242-743

### RF/Automotive

Theresienstrasse 2  
Postfach 3535  
74025 Heilbronn, Germany  
Tel: (49) 71-31-67-0  
Fax: (49) 71-31-67-2340

1150 East Cheyenne Mtn. Blvd.  
Colorado Springs, CO 80906, USA  
Tel: 1(719) 576-3300  
Fax: 1(719) 540-1759

### Biometrics/Imaging/Hi-Rel MPU/ High Speed Converters/RF Datacom

Avenue de Rochepleine  
BP 123  
38521 Saint-Egreve Cedex, France  
Tel: (33) 4-76-58-30-00  
Fax: (33) 4-76-58-34-80

---

### Literature Requests

[www.atmel.com/literature](http://www.atmel.com/literature)

**Disclaimer:** Atmel Corporation makes no warranty for the use of its products, other than those expressly contained in the Company's standard warranty which is detailed in Atmel's Terms and Conditions located on the Company's web site. The Company assumes no responsibility for any errors which may appear in this document, reserves the right to change devices or specifications detailed herein at any time without notice, and does not make any commitment to update the information contained herein. No licenses to patents or other intellectual property of Atmel are granted by the Company in connection with the sale of Atmel products, expressly or by implication. Atmel's products are not authorized for use as critical components in life support devices or systems.

