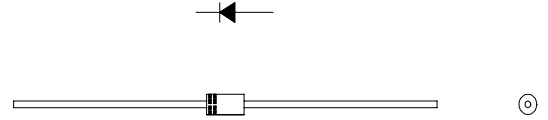

**1A 400V 120ns**

OUTLINE DRAWING

**FRD Type : 10DRA40**
**FEATURES**

- \* Miniature Size
- \* Super Fast Recovery
- \* Low Forward Voltage drop
- \* Low Power Loss, High Efficiency
- \* High Surge Capability
- \* 100 Volts thru 600 Volts Types Available
- \* 52mm Inside Tape Spacing Package Available

**Maximum Ratings**

Approx Net Weight:0.33g

Rating	Symbol	10DRA40			Unit
Repetitive Peak Reverse Voltage	$V_{RRM}$	400			V
Average Rectified Output Current	$I_O$	1.0	$T_a=58^{\circ}\text{C}$ *1	50Hz Half Sine Wave Resistive Load	A
		0.9	$T_a=35^{\circ}\text{C}$ *2		
RMS Forward Current	$I_{F(RMS)}$	1.57			A
Surge Forward Current	$I_{FSM}$	35	50Hz Half Sine Wave, 1cycle, Non-repetitive		A
Operating Junction Temperature Range	$T_{jw}$	- 40 to + 150			$^{\circ}\text{C}$
Storage Temperature Range	$T_{stg}$	- 40 to + 150			$^{\circ}\text{C}$

**Electrical • Thermal Characteristics**

Characteristics	Symbol	Conditions	Min.	Typ.	Max.	Unit	
Peak Reverse Current	$I_{RM}$	$T_j = 25^{\circ}\text{C}$ , $V_{RM} = V_{RRM}$	-	-	10	$\mu\text{A}$	
Peak Forward Voltage	$V_{FM}$	$T_j = 25^{\circ}\text{C}$ , $I_{FM} = 1.0\text{A}$	-	-	1.13	V	
Reverse Recovery Time	trr	$T_a = 25^{\circ}\text{C}$ , $I_{FM} = 1\text{A}$ , $-di/dt = 50\text{A}/\mu\text{s}$			120	ns	
Thermal Resistance	$R_{th(j-a)}$	Junction to Ambient	*1:P.C.Board mounted	-	-	81	$^{\circ}\text{C}/\text{W}$
			*2:Without Fin or P.C.Board mounted			115	

\*1 : P.C. Board mounted (L=8mm, Print Land=10x10mm, Both Sides)

\*2 : Without Fin or P.C. Board mounted

10DRA\_ OUTLINE DRAWING (Dimensions in mm)

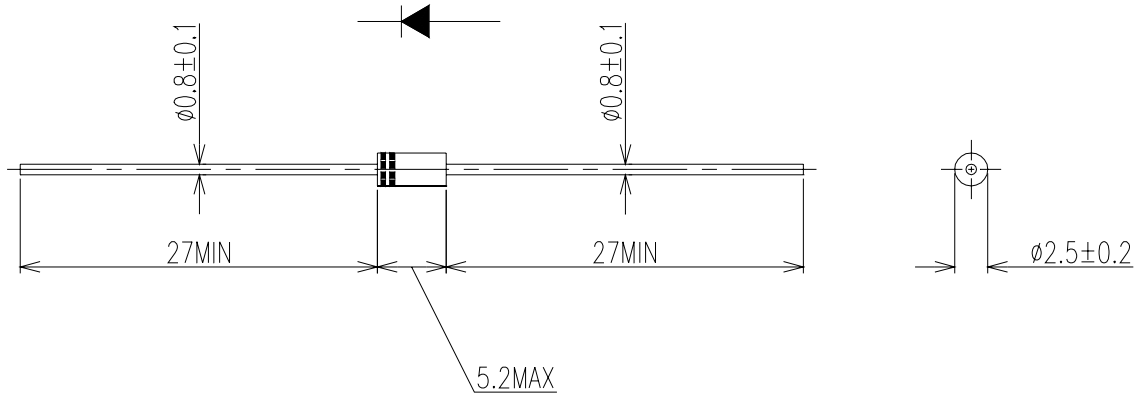

### FORWARD CURRENT VS. VOLTAGE

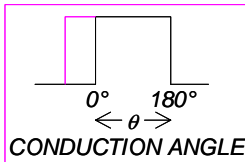
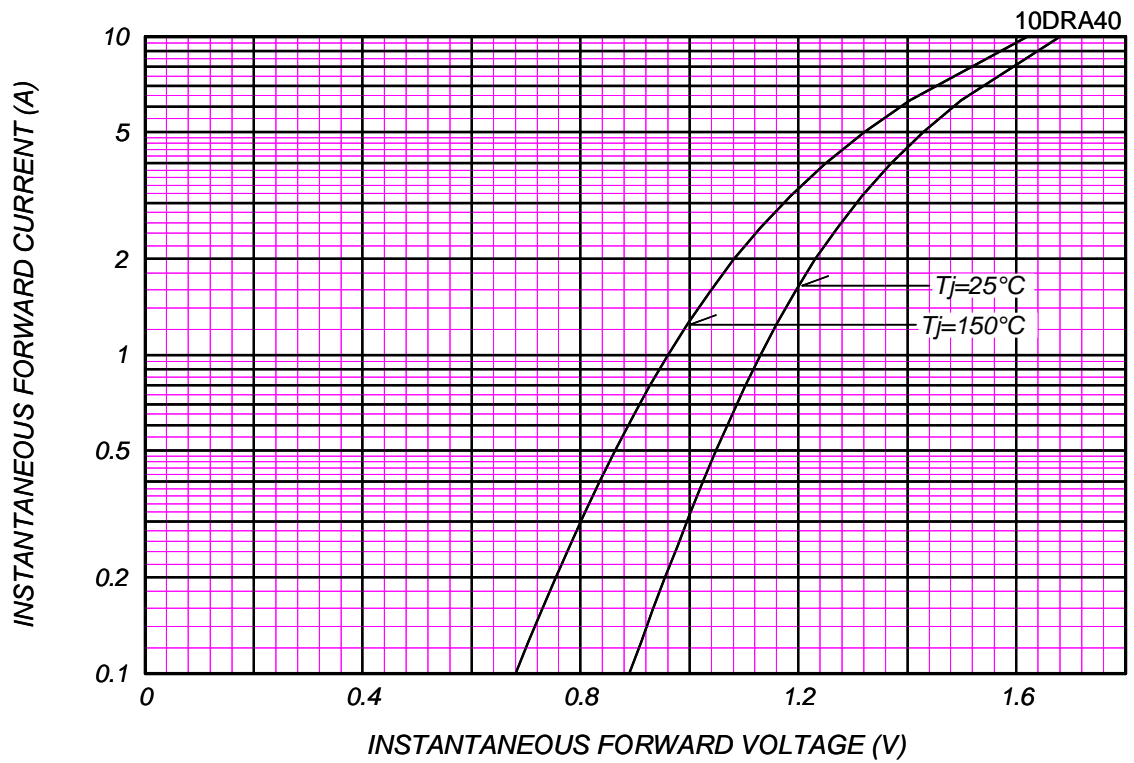

### AVERAGE FORWARD POWER DISSIPATION

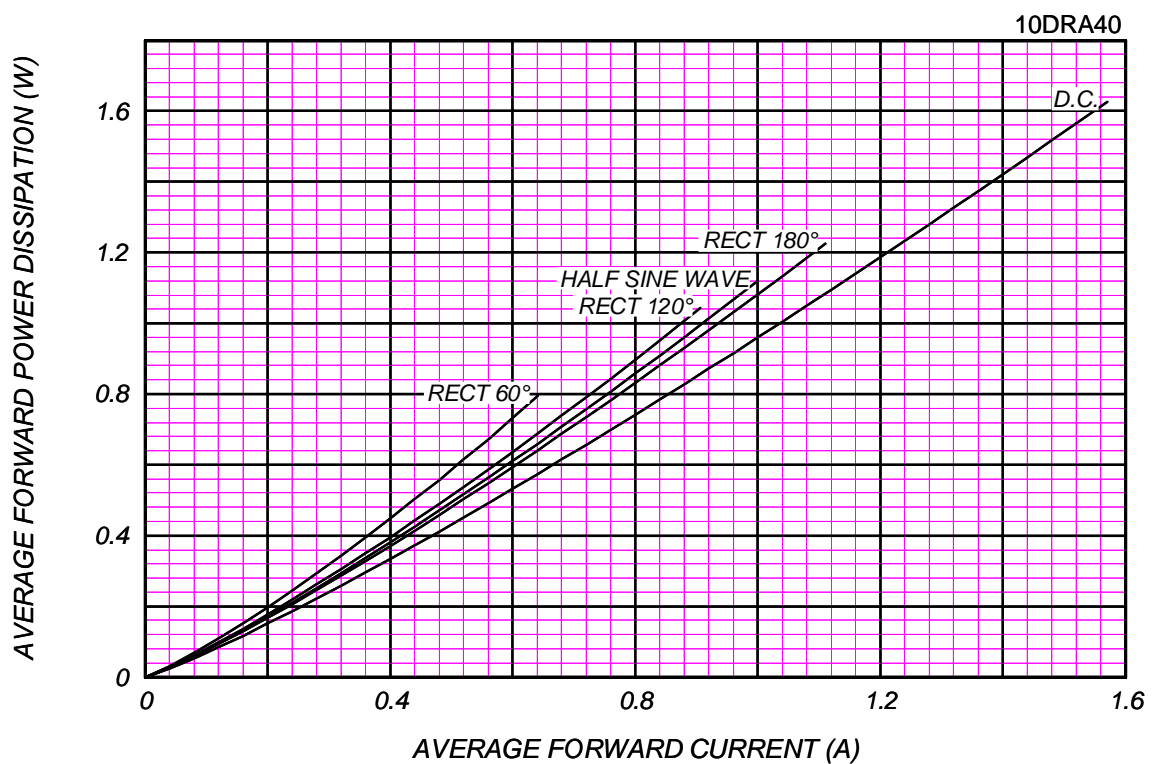

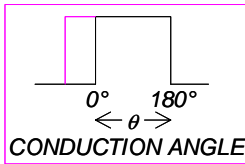

### AVERAGE FORWARD CURRENT VS. AMBIENT TEMPERATURE

P.C. Board mounted (L=8mm,Print Land=10×10mm,Both Sides)

10DRA40

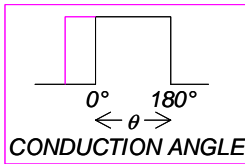
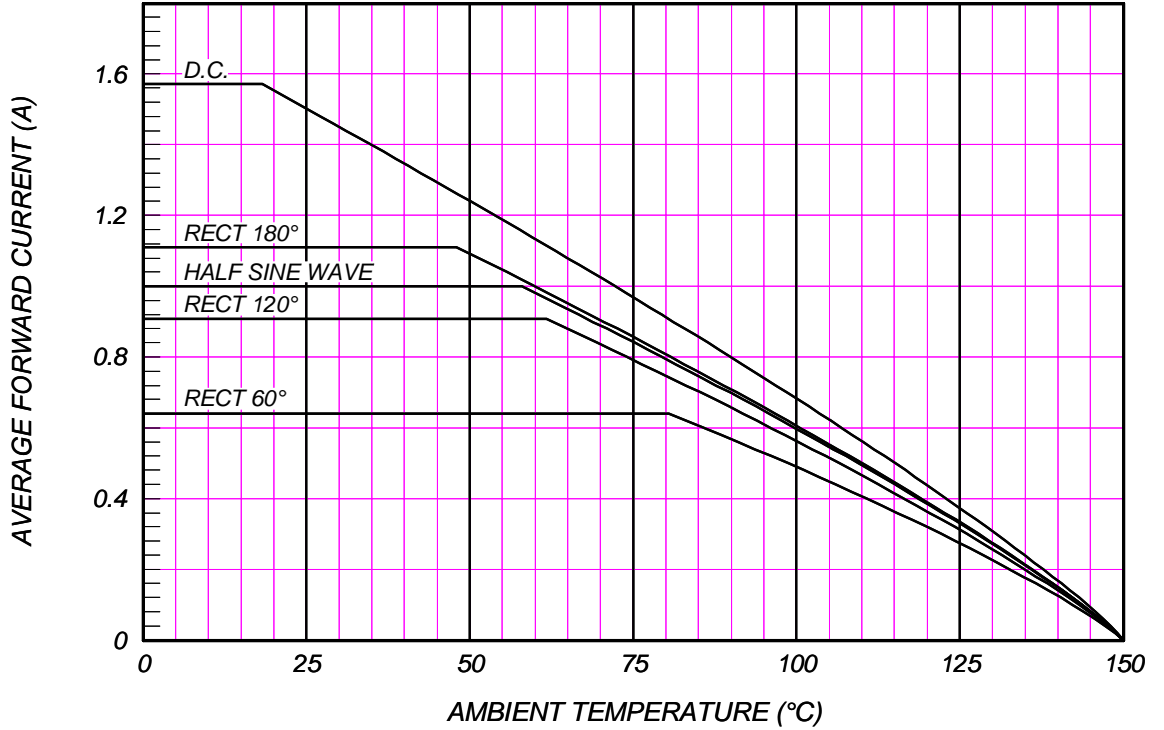

### AVERAGE FORWARD CURRENT VS. AMBIENT TEMPERATURE

Without Fin or P.C. Board

10DRA40

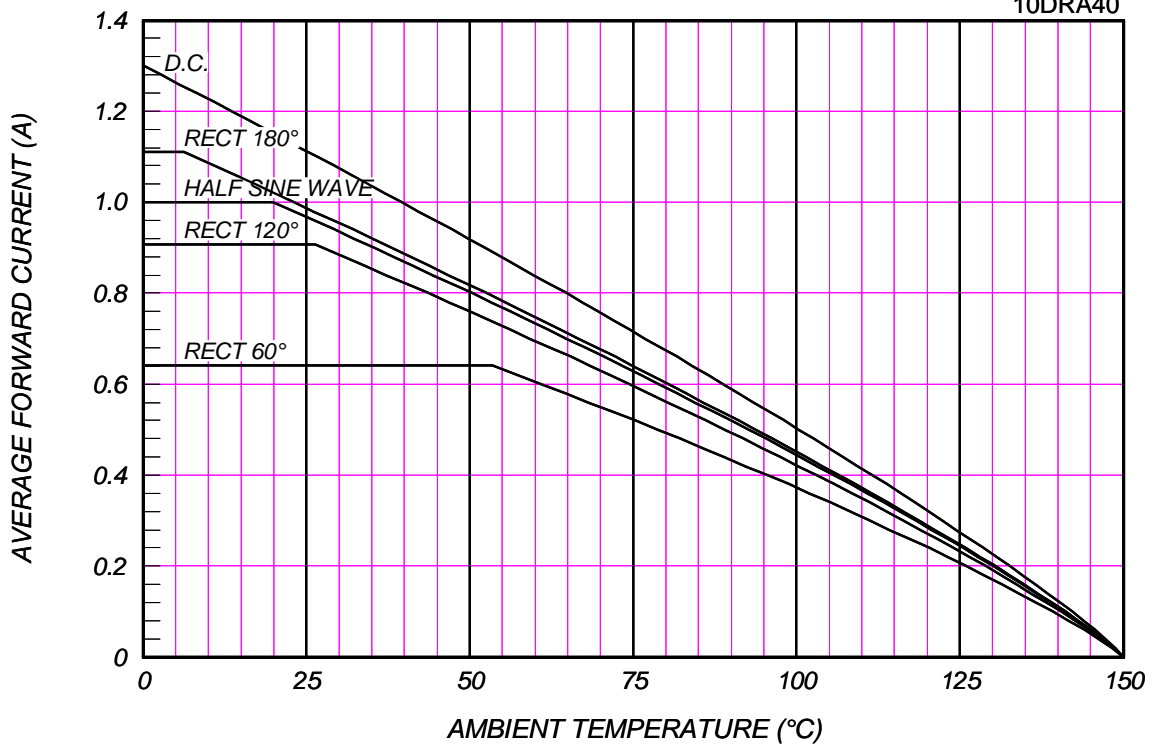

# SURGE CURRENT RATINGS

f=50Hz, Half Sine Wave, Non-Repetitive, No Load

10DRA40

