

Quint Differential Line Receiver

The MC10E100E116 is a quint differential line receiver with emitter-follower outputs. An internally generated reference supply (V_{BB}) is available for single-ended reception.

- 500ps Max. Propagation Delay
- V_{BB} Supply Output
- Dedicated V_{CCO} Pin for Each Receiver
- Extended 100E V_{EE} Range of $-4.2V$ to $-5.46V$
- $75k\Omega$ Input Pulldown Resistors

Active current sources plus a deep collector feature of the MOSAIC III process provide the receivers with excellent common-mode noise rejection. Each receiver has a dedicated V_{CCO} supply lead, providing optimum symmetry and stability.

The receiver design features clamp circuitry to cause a defined state if both the inverting and non-inverting inputs are left open; in this case the Q output goes LOW, while the \bar{Q} output goes HIGH. This feature makes the device ideal for twisted pair applications.

If both inverting and non-inverting inputs are at an equal potential of $> -2.5V$, the receiver does *not* go to a defined state, but rather current-shares in normal differential amplifier fashion, producing output voltage levels midway between HIGH and LOW, or the device may even oscillate.

The device V_{BB} output is intended for use as a reference voltage for single-ended reception of ECL signals to that device only. When using for this purpose, it is recommended that V_{BB} is decoupled to V_{CC} via a $0.01\mu F$ capacitor. Please refer to the interface section of the design guide for information on using the E116 in specialized applications.

The E116 features input pull-down resistors, as does the rest of the ECLinPS family. For applications which require bandwidths greater than that of the E116, the E416 device may be of interest.

MC10E116
MC100E116

QUINT DIFFERENTIAL
LINE RECEIVER



PIN NAMES

Pin	Function
$D_0, \bar{D}_0 - D_4, \bar{D}_4$	Differential Input Pairs
$Q_0, \bar{Q}_0 - Q_4, \bar{Q}_4$	Differential Output Pairs
V_{BB}	Reference Voltage Output.

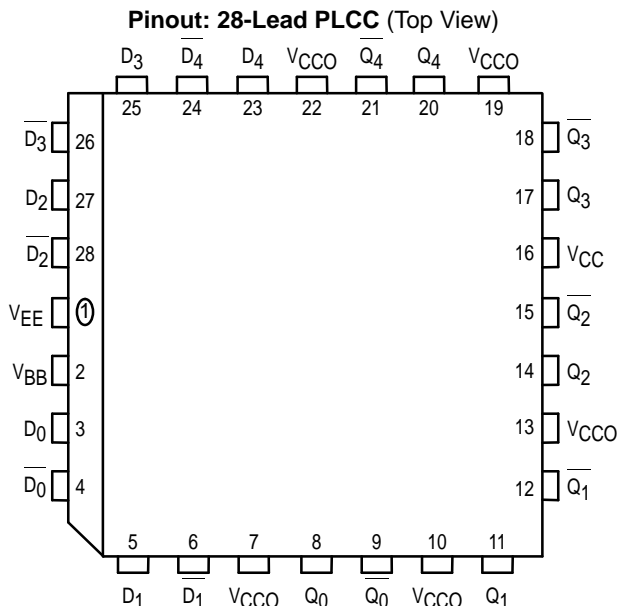

* All V_{CC} and V_{CCO} pins are tied together on the die.



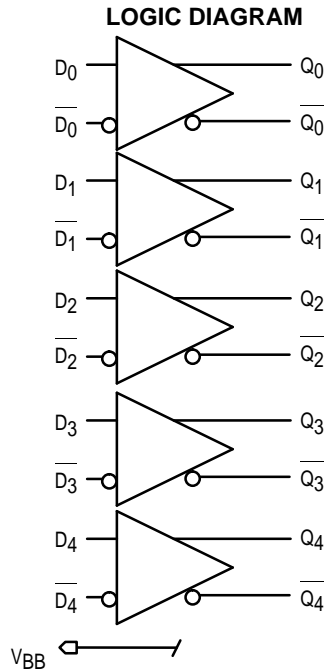

DC CHARACTERISTICS ($V_{EE} = V_{EE}(\text{min})$ to $V_{EE}(\text{max})$; $V_{CC} = V_{CCO} = \text{GND}$)

Symbol	Characteristic	-40°C			0°C			25°C			85°C			Unit	Cond
		Min	Typ	Max	Min	Typ	Max	Min	Typ	Max	Min	Typ	Max		
V_{BB}	Output Reference Voltage	10E	-1.43	-1.30	-1.38	-1.27	-1.35	-1.25	-1.31	-1.19	V				
		100E	-1.38	-1.26	-1.38	-1.26	-1.38	-1.26	-1.38	-1.26					
I_{IH}	Input HIGH Current		200		200		200		200		μA				
I_{EE}	Power Supply Current	10E	29	35	29	35	29	35	29	35	mA				
		100E	29	35	29	35	29	35	29	40					
$V_{PP}(\text{DC})$	Input Sensitivity	150		150		150		150		mV	1				
V_{CMR}	Common Mode Range	-2.0	-0.6		-2.0	-0.6		-2.0	-0.6		V	2			

- Differential input voltage required to obtain a full ECL swing on the outputs.
- V_{CMR} is defined as the range within which the V_{IH} level may vary, with the device still meeting the propagation delay specification. The V_{IL} level must be such that the peak to peak voltage is less than 1.0 V and greater than or equal to $V_{pp}(\text{min})$.

AC CHARACTERISTICS ($V_{EE} = V_{EE}(\text{min})$ to $V_{EE}(\text{max})$; $V_{CC} = V_{CCO} = \text{GND}$)

Symbol	Characteristic	-40°C			0°C to 85°C			Unit	Condition
		Min	Typ	Max	Min	Typ	Max		
t_{PLH} t_{PHL}	Propagation Delay to Output D (Differential) D (Single-Ended)	150	300	500	200	300	450	ps	
		150	300	550	150	300	500		
t_{skew}	Within-Device Skew		50			50		ps	1
t_{skew}	Duty Cycle Skew $t_{PLH} - t_{PHL}$		± 10			± 10		ps	2
$V_{PP}(\text{AC})$	Minimum Input Swing	150			150			mV	3
t_r/t_f	Rise/Fall Time	250	375	625	275	375	575	ps	20-80%

- Within-device skew is defined as identical transitions on similar paths through a device.
- Duty cycle skew is defined only for differential operation when the delays are measured from the cross point of the inputs to the cross point of the outputs.
- Minimum input swing for which AC parameters are guaranteed.

OUTLINE DIMENSIONS

FN SUFFIX
 PLASTIC PLCC PACKAGE
 CASE 776-02
 ISSUE D

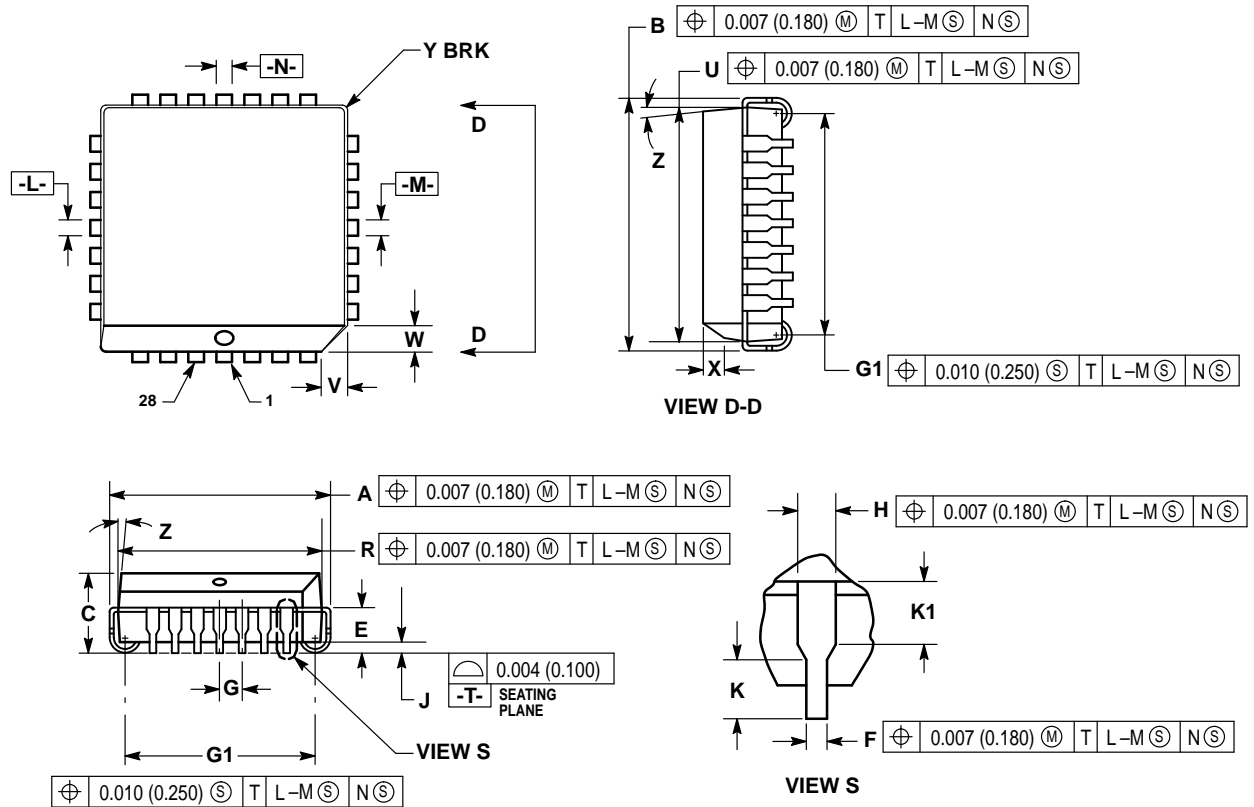

NOTES:

- DATUMS -L-, -M-, AND -N- DETERMINED WHERE TOP OF LEAD SHOULDER EXITS PLASTIC BODY AT MOLD PARTING LINE.
- DIM G1, TRUE POSITION TO BE MEASURED AT DATUM -T-, SEATING PLANE.
- DIM R AND U DO NOT INCLUDE MOLD FLASH. ALLOWABLE MOLD FLASH IS 0.010 (0.250) PER SIDE.
- DIMENSIONING AND TOLERANCING PER ANSI Y14.5M, 1982.
- CONTROLLING DIMENSION: INCH.
- THE PACKAGE TOP MAY BE SMALLER THAN THE PACKAGE BOTTOM BY UP TO 0.012 (0.300). DIMENSIONS R AND U ARE DETERMINED AT THE OUTERMOST EXTREMES OF THE PLASTIC BODY EXCLUSIVE OF MOLD FLASH, TIE BAR BURRS, GATE BURRS AND INTERLEAD FLASH, BUT INCLUDING ANY MISMATCH BETWEEN THE TOP AND BOTTOM OF THE PLASTIC BODY.
- DIMENSION H DOES NOT INCLUDE DAMBAR PROTRUSION OR INTRUSION. THE DAMBAR PROTRUSION(S) SHALL NOT CAUSE THE H DIMENSION TO BE GREATER THAN 0.037 (0.940). THE DAMBAR INTRUSION(S) SHALL NOT CAUSE THE H DIMENSION TO BE SMALLER THAN 0.025 (0.635).

DIM	INCHES		MILLIMETERS	
	MIN	MAX	MIN	MAX
A	0.485	0.495	12.32	12.57
B	0.485	0.495	12.32	12.57
C	0.165	0.180	4.20	4.57
E	0.090	0.110	2.29	2.79
F	0.013	0.019	0.33	0.48
G	0.050 BSC		1.27 BSC	
H	0.026	0.032	0.66	0.81
J	0.020	—	0.51	—
K	0.025	—	0.64	—
R	0.450	0.456	11.43	11.58
U	0.450	0.456	11.43	11.58
V	0.042	0.048	1.07	1.21
W	0.042	0.048	1.07	1.21
X	0.042	0.056	1.07	1.42
Y	—	0.020	—	0.50
Z	2°		10°	
G1	0.410	0.430	10.42	10.92
K1	0.040	—	1.02	—

Motorola reserves the right to make changes without further notice to any products herein. Motorola makes no warranty, representation or guarantee regarding the suitability of its products for any particular purpose, nor does Motorola assume any liability arising out of the application or use of any product or circuit, and specifically disclaims any and all liability, including without limitation consequential or incidental damages. "Typical" parameters which may be provided in Motorola data sheets and/or specifications can and do vary in different applications and actual performance may vary over time. All operating parameters, including "Typicals" must be validated for each customer application by customer's technical experts. Motorola does not convey any license under its patent rights nor the rights of others. Motorola products are not designed, intended, or authorized for use as components in systems intended for surgical implant into the body, or other applications intended to support or sustain life, or for any other application in which the failure of the Motorola product could create a situation where personal injury or death may occur. Should Buyer purchase or use Motorola products for any such unintended or unauthorized application, Buyer shall indemnify and hold Motorola and its officers, employees, subsidiaries, affiliates, and distributors harmless against all claims, costs, damages, and expenses, and reasonable attorney fees arising out of, directly or indirectly, any claim of personal injury or death associated with such unintended or unauthorized use, even if such claim alleges that Motorola was negligent regarding the design or manufacture of the part. Motorola and  are registered trademarks of Motorola, Inc. Motorola, Inc. is an Equal Opportunity/Affirmative Action Employer.

How to reach us:

USA/EUROPE/Locations Not Listed: Motorola Literature Distribution;
P.O. Box 20912; Phoenix, Arizona 85036. 1-800-441-2447 or 602-303-5454

MFAX: RMFAX0@email.sps.mot.com – TOUCHTONE 602-244-6609
INTERNET: <http://Design-NET.com>

JAPAN: Nippon Motorola Ltd.; Tatsumi-SPD-JLDC, 6F Seibu-Butsuryu-Center,
3-14-2 Tatsumi Koto-Ku, Tokyo 135, Japan. 03-81-3521-8315

ASIA/PACIFIC: Motorola Semiconductors H.K. Ltd.; 8B Tai Ping Industrial Park,
51 Ting Kok Road, Tai Po, N.T., Hong Kong. 852-26629298



Copyright © Each Manufacturing Company.

All Datasheets cannot be modified without permission.

This datasheet has been download from :

www.AllDataSheet.com

100% Free DataSheet Search Site.

Free Download.

No Register.

Fast Search System.

www.AllDataSheet.com