

8-Bit Ripple Counter

The MC10E/100E137 is a very high speed binary ripple counter. The two least significant bits were designed with very fast edge rates while the more significant bits maintain standard ECLinPS™ output edge rates. This allows the counter to operate at very high frequencies while maintaining a moderate power dissipation level.

- 1.8GHz Minimum Count Frequency
- Differential Clock Input and Data Output Pins
- V_{BB} Output for Single-Ended Use
- Internal 75kΩ Input Pulldown Resistors
- Synchronous and Asynchronous Enable Pins
- Asynchronous Master Reset
- Extended 100E V_{EE} Range of -4.2V to -5.46V

The device is ideally suited for multiple frequency clock generation as well as a counter in a high performance ATE time measurement board.

Both asynchronous and synchronous enables are available to maximize the device's flexibility for various applications. The asynchronous enable input, A_Start, when asserted enables the counter while overriding any synchronous enable signals. The E137 features XORed enable inputs, EN1 and EN2, which are synchronous to the CLK input. When only one synchronous enable is asserted the counter becomes disabled on the next CLK transition; all outputs remain in the previous state poised for the other synchronous enable or A_Start to be asserted to re-enable the counter. Asserting both synchronous enables causes the counter to become enabled on the next transition of the CLK. If EN1 (or EN2) and CLK edges are coincident, sufficient delay has been inserted in the CLK path (to compensate for the XOR gate delay and the internal D-flip flop setup time) to insure that the synchronous enable signal is clocked correctly, hence, the counter is disabled.

The E137 can also be driven single-endedly utilizing the V_{BB} output supply as the voltage reference for the CLK input signal. If a single-ended signal is to be used the V_{BB} pin should be connected to the CLK input and bypassed to ground via a 0.01μF capacitor. V_{BB} can only source/sink 0.5mA, therefore it should be used as a switching reference for the E137 only.

All input pins left open will be pulled LOW via an input pulldown resistor. Therefore, do not leave the differential CLK inputs open. Doing so causes the current source transistor of the input clock gate to become saturated, thus upsetting the internal bias regulators and jeopardizing the stability of the device.

The asynchronous Master Reset resets the counter to an all zero state upon assertion.

MC10E137
MC100E137

8-BIT RIPPLE
COUNTER

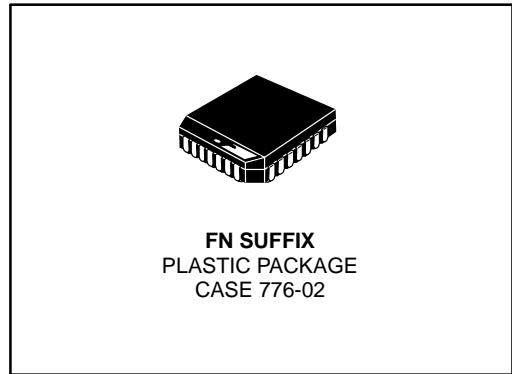

PIN NAMES

PIN	FUNCTION
CLK, $\overline{\text{CLK}}$	Differential Clock Inputs
Q0-Q7, $\overline{\text{Q0-Q7}}$	Differential Q Outputs
A_Start	Asynchronous Enable Input
EN1, EN2	Synchronous Enable Inputs
MR	Asynchronous Master Reset
V _{BB}	Switching Reference Output

LOGIC DIAGRAM

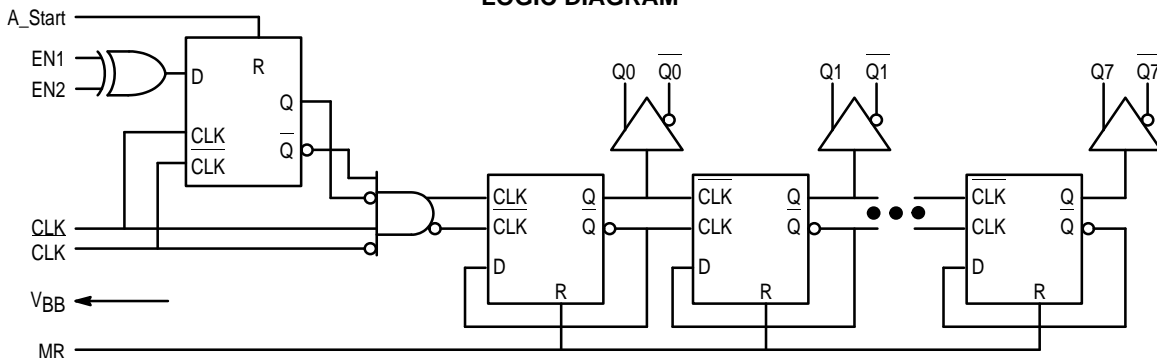

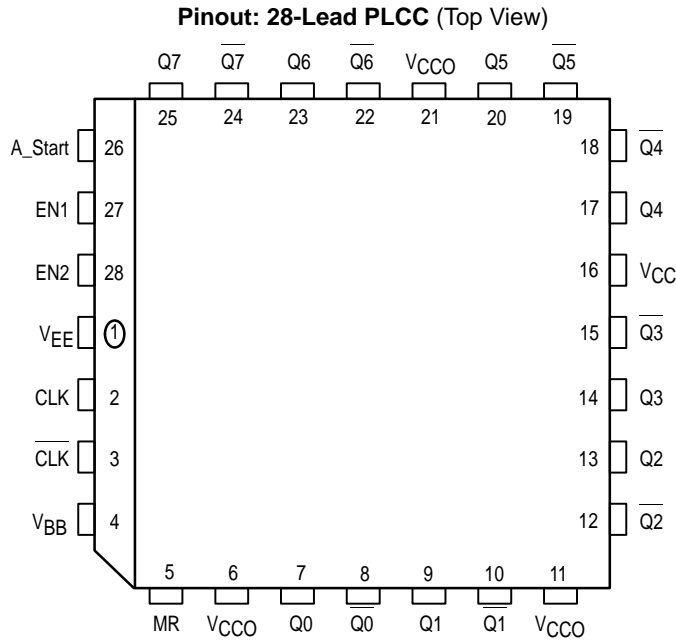

* All VCC and VCCO pins are tied together on the die.

SEQUENTIAL TRUTH TABLE

Function	EN1	EN2	A_Start	MR	CLK	Q7	Q6	Q5	Q4	Q3	Q2	Q1	Q0
Reset	X	X	X	H	X	L	L	L	L	L	L	L	L
Count	L	L	L	L	Z	L	L	L	L	L	L	L	H
	L	L	L	L	Z	L	L	L	L	L	L	H	L
	L	L	L	L	Z	L	L	L	L	L	L	H	H
Stop	H	L	L	L	Z	L	L	L	L	L	L	H	H
	H	L	L	L	Z	L	L	L	L	L	L	H	H
Asynch Start	H	L	H	L	Z	L	L	L	L	L	H	L	L
	H	L	H	L	Z	L	L	L	L	L	H	L	H
	L	L	H	L	Z	L	L	L	L	L	H	H	L
Count	L	L	L	L	Z	L	L	L	L	L	H	H	H
	L	L	L	L	Z	L	L	L	L	H	L	L	L
	L	L	L	L	Z	L	L	L	L	H	L	L	H
Stop	L	H	L	L	Z	L	L	L	L	H	L	L	H
	L	H	L	L	Z	L	L	L	L	H	L	L	H
Synch Start	H	H	L	L	Z	L	L	L	L	H	L	H	L
	H	H	L	L	Z	L	L	L	L	H	L	H	H
	H	H	L	L	Z	L	L	L	L	H	H	L	L
Stop	H	L	L	L	Z	L	L	L	L	H	H	L	L
	H	L	L	L	Z	L	L	L	L	H	H	L	L
Count	L	L	L	L	Z	L	L	L	L	H	H	L	H
	L	L	L	L	Z	L	L	L	L	H	H	H	L
	L	L	L	L	Z	L	L	L	L	H	H	H	H
Reset	X	X	X	H	X	L	L	L	L	L	L	L	L

Z = Low to High Transition

DC CHARACTERISTICS ($V_{EE} = V_{EE}(\text{min})$ to $V_{EE}(\text{max})$; $V_{CC} = V_{CCO} = \text{GND}$)

Symbol	Characteristic	0°C			25°C			85°C			Unit	Condition
		Min	Typ	Max	Min	Typ	Max	Min	Typ	Max		
V _{BB}	Output Reference Voltage 10E 100E	-1.38		-1.27	-1.35		-1.25	-1.31		-1.19	V	
		-1.38		-1.27	-1.38		-1.26	-1.38		-1.26		
I _{IH}	Input HIGH Current			150			150			150	μA	
I _{EE}	Power Supply Current 10E 100E		121	145		121	145		121	145	mA	
			121	145		121	145		139	167		

AC CHARACTERISTICS ($V_{EE} = V_{EE}(\text{min})$ to $V_{EE}(\text{max})$; $V_{CC} = V_{CCO} = \text{GND}$)

Symbol	Characteristic	0°C			25°C			85°C			Unit	Condition
		Min	Typ	Max	Min	Typ	Max	Min	Typ	Max		
f _{COUNT}	Maximum Count Frequency	1800	2200		1800	2200		1800	2200		MHz	
t _{PLH} t _{PHL}	Propagation Delay to Output CLK to Q0 CLK to Q1 CLK to Q2 CLK to Q3 CLK to Q4 CLK to Q5 CLK to Q6 CLK to Q7 A_Start to Q0 MR to Q0	1300 1600 1950 2275 2625 2950 3250 3575 950 700	1700 2025 2425 2750 3125 3450 3775 4075 1325 1000	2150 2500 2925 3350 3750 4150 4450 4800 1700 1300	1300 1600 1950 2275 2625 2950 3250 3575 950 700	1700 2050 2450 2775 3150 3475 3800 4125 1325 1000	2150 2500 2925 3350 3750 4150 4450 4800 1700 1300	1350 1650 2025 2350 2700 3050 3375 3700 950 700	1750 2100 2500 2850 3225 3550 3925 4250 1325 1000	2200 2550 3000 3425 3825 4250 4600 4950 1700 1300	ps	
t _s	Setup Time (EN1, EN2)	0	-150		0	-150		0	-150		ps	
t _h	Hold Time (EN1, EN2)	300	150		300	150		300	150		ps	
t _{RR}	Reset Recovery Time MR, A_Start	400	200		400	200		400	200		ps	
t _{PW}	Minimum Pulse Width CLK, MR, A_Start	400			400			400			ps	
V _{PP}	Minimum Input Swing (CLK)	0.25		1.0	0.25		1.0	0.25		1.0	V	Note 1
V _{CMR}	Com Mode Range (CLK)	-0.4		-2.0	-0.4		-2.0	-0.4		-2.0	V	
t _r t _f	Rise/Fall Times Q0, Q1 Q2 to Q7	150 275		400 600	150 275		400 600	150 275		400 600	ps	20%–80%

1. Minimum input swing for which AC parameters are guaranteed. Full DC ECL output swings will be generated with only 50mV input swings.

OUTLINE DIMENSIONS

FN SUFFIX
 PLASTIC PLCC PACKAGE
 CASE 776-02
 ISSUE D

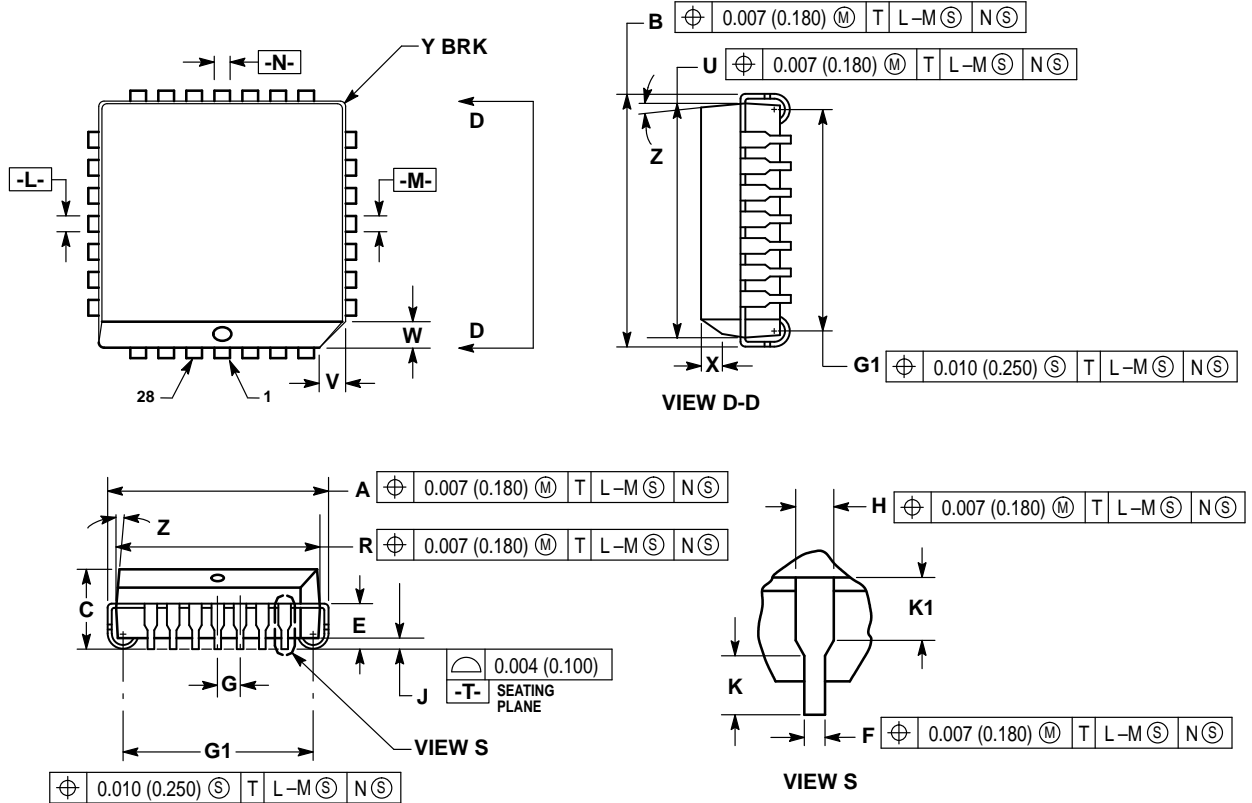

NOTES:

- DATUMS -L-, -M-, AND -N- DETERMINED WHERE TOP OF LEAD SHOULDER EXITS PLASTIC BODY AT MOLD PARTING LINE.
- DIM G1, TRUE POSITION TO BE MEASURED AT DATUM -T-, SEATING PLANE.
- DIM R AND U DO NOT INCLUDE MOLD FLASH. ALLOWABLE MOLD FLASH IS 0.010 (0.250) PER SIDE.
- DIMENSIONING AND TOLERANCING PER ANSI Y14.5M, 1982.
- CONTROLLING DIMENSION: INCH.
- THE PACKAGE TOP MAY BE SMALLER THAN THE PACKAGE BOTTOM BY UP TO 0.012 (0.300). DIMENSIONS R AND U ARE DETERMINED AT THE OUTERMOST EXTREMES OF THE PLASTIC BODY EXCLUSIVE OF MOLD FLASH, TIE BAR BURRS, GATE BURRS AND INTERLEAD FLASH, BUT INCLUDING ANY MISMATCH BETWEEN THE TOP AND BOTTOM OF THE PLASTIC BODY.
- DIMENSION H DOES NOT INCLUDE DAMBAR PROTRUSION OR INTRUSION. THE DAMBAR PROTRUSION(S) SHALL NOT CAUSE THE H DIMENSION TO BE GREATER THAN 0.037 (0.940). THE DAMBAR INTRUSION(S) SHALL NOT CAUSE THE H DIMENSION TO BE SMALLER THAN 0.025 (0.635).

DIM	INCHES		MILLIMETERS	
	MIN	MAX	MIN	MAX
A	0.485	0.495	12.32	12.57
B	0.485	0.495	12.32	12.57
C	0.165	0.180	4.20	4.57
E	0.090	0.110	2.29	2.79
F	0.013	0.019	0.33	0.48
G	0.050 BSC		1.27 BSC	
H	0.026	0.032	0.66	0.81
J	0.020	—	0.51	—
K	0.025	—	0.64	—
R	0.450	0.456	11.43	11.58
U	0.450	0.456	11.43	11.58
V	0.042	0.048	1.07	1.21
W	0.042	0.048	1.07	1.21
X	0.042	0.056	1.07	1.42
Y	—	0.020	—	0.50
Z	2°		10°	
G1	0.410	0.430	10.42	10.92
K1	0.040	—	1.02	—

Motorola reserves the right to make changes without further notice to any products herein. Motorola makes no warranty, representation or guarantee regarding the suitability of its products for any particular purpose, nor does Motorola assume any liability arising out of the application or use of any product or circuit, and specifically disclaims any and all liability, including without limitation consequential or incidental damages. "Typical" parameters which may be provided in Motorola data sheets and/or specifications can and do vary in different applications and actual performance may vary over time. All operating parameters, including "Typicals" must be validated for each customer application by customer's technical experts. Motorola does not convey any license under its patent rights nor the rights of others. Motorola products are not designed, intended, or authorized for use as components in systems intended for surgical implant into the body, or other applications intended to support or sustain life, or for any other application in which the failure of the Motorola product could create a situation where personal injury or death may occur. Should Buyer purchase or use Motorola products for any such unintended or unauthorized application, Buyer shall indemnify and hold Motorola and its officers, employees, subsidiaries, affiliates, and distributors harmless against all claims, costs, damages, and expenses, and reasonable attorney fees arising out of, directly or indirectly, any claim of personal injury or death associated with such unintended or unauthorized use, even if such claim alleges that Motorola was negligent regarding the design or manufacture of the part. Motorola and  are registered trademarks of Motorola, Inc. Motorola, Inc. is an Equal Opportunity/Affirmative Action Employer.

How to reach us:

USA/EUROPE/Locations Not Listed: Motorola Literature Distribution;
P.O. Box 20912; Phoenix, Arizona 85036. 1-800-441-2447 or 602-303-5454

MFAX: RMFAX0@email.sps.mot.com – TOUCHTONE 602-244-6609
INTERNET: <http://Design-NET.com>

JAPAN: Nippon Motorola Ltd.; Tatsumi-SPD-JLDC, 6F Seibu-Butsuryu-Center,
3-14-2 Tatsumi Koto-Ku, Tokyo 135, Japan. 03-81-3521-8315

ASIA/PACIFIC: Motorola Semiconductors H.K. Ltd.; 8B Tai Ping Industrial Park,
51 Ting Kok Road, Tai Po, N.T., Hong Kong. 852-26629298



Copyright © Each Manufacturing Company.

All Datasheets cannot be modified without permission.

This datasheet has been download from :

www.AllDataSheet.com

100% Free DataSheet Search Site.

Free Download.

No Register.

Fast Search System.

www.AllDataSheet.com