



# Rail-to-Rail, Fault-Protected, SPST Analog Switches

MAX4510/MAX4520

## General Description

The MAX4510/MAX4520 single-pole/single-throw (SPST), fault-protected analog switches feature a fault-protected input and Rail-to-Rail<sup>®</sup> signal-handling capability. The normally open (NO) and normally closed (NC) terminals are protected from overvoltage faults up to 36V during power-on and 44V with power off. During a fault condition, the switch input terminal (NO or NC) becomes an open circuit; only nanoamperes of leakage current flow from the fault source, and the switch output (COM) furnishes up to 13mA of the appropriate polarity supply voltage to the load. This ensures unambiguous rail-to-rail outputs when a fault begins and ends.

On-resistance is 160Ω max. The off-leakage current is only 0.5nA at +25°C and 10nA at +85°C. The MAX4510 is a normally closed switch, while the MAX4520 is a normally open switch. These CMOS switches operate with dual power supplies ranging from ±4.5V to ±20V or a single supply between +9V and +36V.

The digital input has +0.8V and +2.4V logic thresholds, ensuring both TTL- and CMOS-logic compatibility when using ±15V or a single +12V supply. The MAX4510/MAX4520 are available in 6-pin SOT23 and 8-pin μMAX packages.

## Applications

Data Acquisition  
Industrial and Process-Control Systems  
Avionics  
ATE Equipment  
Redundant/Backup Systems

## Ordering Information

PART	TEMP. RANGE	PIN-PACKAGE	TOP MARK
MAX4510EUT-T	-40°C to +85°C	6 SOT23-6	AABZ
MAX4510EUA	-40°C to +85°C	8 μMAX	—
MAX4520EUT-T	-40°C to +85°C	6 SOT23-6	AADK
MAX4520EUA	-40°C to +85°C	8 μMAX	—

Rail-to-Rail is a registered trademark of Nippon Motorola, Ltd.

## Features

- ◆ ±40V Fault Protection with Power Off
- ◆ ±36V Fault Protection with ±15V Supplies
- ◆ Switch is Off with Power Removed
- ◆ Rail-to-Rail Signal Handling
- ◆ 160Ω max Signal Paths with ±15V Supplies
- ◆ On-Switch Turns Off with Overvoltage
- ◆ 0.5nA Off-Leakage Current
- ◆ Output Clamped to Appropriate Supply Voltage During Fault Condition; No Transition Glitch
- ◆ No Power-Supply Sequencing Required
- ◆ ±4.5V to ±20V Dual Supplies
- ◆ +9V to +36V Single Supply
- ◆ Low Power Consumption: <2mW
- ◆ TTL- and CMOS-Compatible Logic Inputs with Single +9V to +15V or ±15V Supplies

## Pin Configurations/Truth Tables

TOP VIEW

SOT23

( ) ARE FOR MAX4520.

IN	MAX4510	MAX4520
0	ON	OFF
1	OFF	ON

SWITCHES SHOWN FOR LOGIC "0" INPUT.  
ALL SWITCHES ARE OFF WITH POWER REMOVED.

Pin Configurations continued at end of data sheet.



# Rail-to-Rail, Fault-Protected, SPST Analog Switches

## ABSOLUTE MAXIMUM RATINGS

(Voltages Referenced to GND)

V+	-0.3V to +44.0V
V-	-44.0V to +0.3V
V+ to V-	-0.3V to +44.0V
COM, IN (Note 1)	(V- - 0.3V) to (V+ + 0.3V)
NC, NO (Note 2)	(V+ - 36V) to (V- + 36V)
NC, NO to COM	-36V to +36V
Continuous Current into Any Terminal	±30mA
Peak Current into Any Terminal (pulsed at 1ms, 10% duty cycle)	±50mA

Continuous Power Dissipation ( $T_A = +70^\circ\text{C}$ ) (Note 2)

6-Pin SOT23-6 (derate 7.1mW/°C above +70°C)	696mW
8-Pin $\mu$ MAX (derate 4.10mW/°C above +70°C)	330mW
Operating Temperature Ranges	
MAX45_0EUT	-40°C to +85°C
MAX45_0EUA	-40°C to +85°C
Storage Temperature Range	
	-65°C to +150°C
Lead Temperature (soldering, 10sec)	
	+300°C

**Note 1:** COM and IN pins are not fault protected. Signals on COM or IN exceeding V+ or V- are clamped by internal diodes. Limit forward diode current to maximum current rating.

**Note 2:** NC and NO pins are fault protected. Signals on NC or NO exceeding -36V to +36V may damage the device. These limits apply with power applied to V+ or V-, or  $\pm 40\text{V}$  with V+ = V- = 0.

Stresses beyond those listed under "Absolute Maximum Ratings" may cause permanent damage to the device. These are stress ratings only, and functional operation of the device at these or any other conditions beyond those indicated in the operational sections of the specifications is not implied. Exposure to absolute maximum rating conditions for extended periods may affect device reliability.

## ELECTRICAL CHARACTERISTICS—Dual Supplies

(V+ = +15V, V- = -15V, GND = 0,  $V_{IH} = 2.4\text{V}$ ,  $V_{IL} = 0.8\text{V}$ ,  $T_A = T_{MIN}$  to  $T_{MAX}$ , unless otherwise noted. Typical values are at  $T_A = +25^\circ\text{C}$ .) (Note 3)

PARAMETER	SYMBOL	CONDITIONS	$T_A$	MIN	TYP	MAX	UNITS
<b>ANALOG SWITCH</b>							
Fault-Free Analog Signal Range	$V_{NO}, V_{NC}$	Applies with power on or off	E	V-		V+	V
On-Resistance	$R_{ON}$	$V_{COM} = \pm 10\text{V}$ , $I_{COM} = 1\text{mA}$	+25°C		125	160	$\Omega$
			E			225	
NO or NC Off-Leakage Current (Notes 4, 5)	$I_{NO(OFF)}, I_{NC(OFF)}$	$V_{COM} = \pm 14\text{V}$ ; $V_{NO}, V_{NC} = \mp 14\text{V}$	+25°C	-0.5	0.01	0.5	nA
			E	-10		10	
COM Off-Leakage Current (Notes 4, 5)	$I_{COM(OFF)}$	$V_{COM} = \pm 14\text{V}$ ; $V_{NO}, V_{NC} = \mp 14\text{V}$	+25°C	-0.5	0.01	0.5	nA
			E	-10		10	
COM On-Leakage Current (Notes 4, 5)	$I_{COM(ON)}$	$V_{COM} = \pm 14\text{V}$ ; $V_{NO}, V_{NC} = \pm 14\text{V}$ or unconnected	+25°C	-0.5	0.01	0.5	nA
			E	-20		20	
<b>FAULT</b> (V+ = +15V, V- = -15V, unless otherwise noted.)							
Fault-Protected Analog Signal Range	$V_{NO}, V_{NC}$	Applies with power on (Note 6)	E			36	V
		Applies with power off (Note 6)				-40	
COM Off-Leakage Current, Supplies On	$I_{COM(OFF)}$	$V_{NO}$ or $V_{NC} = \pm 36\text{V}$	+25°C	-10		10	nA
			E	-200		200	
NO or NC Input Leakage Current, Supplies On	$I_{NO}, I_{NC}$	$V_{NO}$ or $V_{NC} = \pm 36\text{V}$ , $V_{COM} = \mp 10\text{V}$	+25°C	-20		20	nA
			E	-200		200	
NO or NC Input Leakage Current, Supplies Off	$I_{NO}, I_{NC}$	$V_{NO}$ or $V_{NC} = \pm 40\text{V}$ , $V_+ = 0, V_- = 0$	+25°C	-20	0.1	20	nA
			E	-200		200	
Clamp Output Current, Supplies On	$I_{COM}$	$V_{NO}$ or $V_{NC} = 36\text{V}$	+25°C			8	mA
		$V_{NO}$ or $V_{NC} = -36\text{V}$				-12	

# Rail-to-Rail, Fault-Protected, SPST Analog Switches

MAX4510/MAX4520

## ELECTRICAL CHARACTERISTICS—Dual Supplies (continued)

( $V_+ = +15V$ ,  $V_- = -15V$ ,  $V_{IH} = 2.4V$ ,  $V_{IL} = 0.8V$ ,  $GND = 0$ ,  $T_A = T_{MIN}$  to  $T_{MAX}$ , unless otherwise noted. Typical values are at  $T_A = +25^\circ C$ .) (Note 3)

PARAMETER	SYMBOL	CONDITIONS	$T_A$	MIN	TYP	MAX	UNITS
Clamp Output Resistance, Supplies On	$R_{COM}$	$V_{NO}$ or $V_{NC} = \pm 36V$	+25°C	1	2.5		k $\Omega$
			E		3		
Fault Trip Threshold			+25°C	$V_- - 0.4$		$V_+ + 0.4$	V
Fault Output Turn-On Delay Time		$V_{IN} = \pm 25V$ , $R_L = 10k\Omega$	+25°C		10		ns
Fault Recovery Time		$V_{IN} = \pm 25V$ , $R_L = 10k\Omega$	+25°C		2.5		$\mu s$
<b>LOGIC INPUT</b>							
IN Input Logic High	$V_{INH}$		E	2.4			V
IN Input Logic Low	$V_{INL}$		E			0.8	V
IN Input Current	$I_{INH}$ , $I_{INL}$	$V_{IN} = 0.8V$ or $2.4V$	+25°C	-1	0.03	1	$\mu A$
			E	-5		5	
<b>SWITCH DYNAMIC CHARACTERISTICS</b>							
Turn-On Time	$t_{ON}$	$V_{NO}$ or $V_{NC} = \pm 10V$ , $R_L = 2k\Omega$ , $C_L = 35pF$ , Figure 2	+25°C		350	500	ns
			E			600	
Turn-Off Time	$t_{OFF}$	$V_{NO}$ or $V_{NC} = \pm 10V$ , $R_L = 2k\Omega$ , $C_L = 35pF$ , Figure 2	+25°C		60	175	ns
			E			250	
Charge Injection (Note 7)	Q	$C_L = 1nF$ , $V_{NO} = 0$ , $R_S = 0\Omega$ , Figure 3	+25°C		1.5	5	pC
NO or NC Off-Capacitance	$C_{N(OFF)}$	$f = 1MHz$ , Figure 4	+25°C		10		pF
COM Off-Capacitance	$C_{COM(OFF)}$	$f = 1MHz$ , Figure 4	+25°C		5		pF
COM On-Capacitance	$C_{COM(ON)}$	$f = 1MHz$ , Figure 4	+25°C		10		pF
Off-Isolation (Note 8)	$V_{CISO}$	$R_L = 50\Omega$ , $C_L = 15pF$ , $V_{N-} = 1V_{RMS}$ , $f = 1MHz$ , Figure 5	+25°C		-62		dB
<b>POWER SUPPLY</b>							
Power-Supply Range	$V_+$ , $V_-$		E	$\pm 4.5$		$\pm 20$	V
$V_+$ Supply Current	I+	$V_{IN} = 0$ or $5V$	+25°C		100	175	$\mu A$
			E			250	
$V_-$ Supply Current	I-	$V_{IN} = 0$ or $5V$	+25°C		50	100	$\mu A$
			E			175	
GND Supply Current	I <sub>GND</sub>	$V_{IN} = 0$ or $15V$	+25°C	-1	0.01	1	$\mu A$
			E			10	
		$V_{IN} = 5V$	+25°C		50	100	
			E			175	

# Rail-to-Rail, Fault-Protected, SPST Analog Switches

## ELECTRICAL CHARACTERISTICS—Single +12V Supply

( $V_+ = +12V$ ,  $V_- = 0$ ,  $GND = 0$ ,  $V_{IH} = 2.4V$ ,  $V_{IL} = 0.8V$ ,  $T_A = T_{MIN}$  to  $T_{MAX}$ , unless otherwise noted. Typical values are at  $T_A = +25^\circ C$ .) (Note 3)

PARAMETER	SYMBOL	CONDITIONS	$T_A$	MIN	TYP	MAX	UNITS
<b>ANALOG SWITCH</b>							
Fault-Free Analog Signal Range	$V_{NO}, V_{NC}$	Applies with power on or off	E	0		$V_+$	V
On-Resistance	$R_{ON}$	$V_{COM} = 10V$ , $I_{COM} = 1mA$	+25°C		260	390	$\Omega$
			E			500	
NO or NC Off-Leakage Current (Notes 4, 5, 9)	$I_{NO(OFF)},$ $I_{NC(OFF)}$	$V_{COM} = 10V, 1V$ ; $V_{NO}, V_{NC} = 1V, 10V$	+25°C	-0.5	0.01	0.5	nA
			E	-10		10	
COM Off-Leakage Current (Notes 4, 5, 9)	$I_{COM(OFF)}$	$V_{COM} = 1V, 10V$ ; $V_{NO}, V_{NC} = 10V, 1V$	+25°C	-0.5	0.01	0.5	nA
			E	-10		10	
COM On-Leakage Current (Notes 4, 5, 9)	$I_{COM(ON)}$	$V_{COM} = 1V, 10V$ ; $V_{NO}, V_{NC} =$ 1V, 10V, or unconnected	+25°C	-0.5	0.01	0.5	nA
			E	-20		20	
<b>FAULT</b>							
Fault-Protected Analog Signal Range	$V_{NO}, V_{NC}$	Applies with power on (Note 6)	E	-36		36	V
		Applies with power off (Note 6)		-40		40	
COM Off-Leakage Current, Supply On	$I_{COM}$	$V_{NO}$ or $V_{NC} = \pm 36V$	+25°C	-10		10	nA
			E	-200		200	
NO or NC Input Leakage Current, Supply On	$I_{NO}, I_{NC}$	$V_{NO}$ or $V_{NC} = \pm 36V$ , $V_{COM} = 0$	+25°C	-20		20	nA
			E	-200		200	
NO or NC Input Leakage Current, Supply Off	$I_{NO}, I_{NC}$	$V_{NO}$ or $V_{NC} = \pm 40V$ , $V_+ = 0, V_- = 0$	+25°C	-20	0.1	20	nA
			E	-200		200	
Clamp Output Current, Supply On	$I_{COM}$	$V_{NO}$ or $V_{NC} = 36V$	+25°C	2	3	5	mA
Clamp Output Resistance, Supply On	$R_{COM}$	$V_{NO}$ or $V_{NC} = 36V$	+25°C		2.4	5	k $\Omega$
<b>LOGIC INPUT</b>							
IN Input Logic High	$V_{INH}$		E	2.4			V
IN Input Logic Low	$V_{INL}$		E			0.8	V
IN Input Current	$I_{INH}, I_{INL}$	$V_{IN} = 0.8V$ or $2.4V$	+25°C	-1	0.03	1	$\mu A$
			E	-5		5	

# Rail-to-Rail, Fault-Protected, SPST Analog Switches

MAX4510/MAX4520

## ELECTRICAL CHARACTERISTICS—Single +12V Supply (continued)

(V+ = +12V, V- = 0, GND = 0, V<sub>IH</sub> = 2.4V, V<sub>IL</sub> = 0.8V, T<sub>A</sub> = T<sub>MIN</sub> to T<sub>MAX</sub>, unless otherwise noted. Typical values are at T<sub>A</sub> = +25°C.) (Note 3)

PARAMETER	SYMBOL	CONDITIONS	T <sub>A</sub>	MIN	TYP	MAX	UNITS
<b>SWITCH DYNAMIC CHARACTERISTICS</b>							
Turn-On Time	t <sub>ON</sub>	V <sub>NO</sub> or V <sub>NC</sub> = 7V, R <sub>L</sub> = 2kΩ, C <sub>L</sub> = 35pF, Figure 2	+25°C	500	750		ns
			E		1000		
Turn-Off Time	t <sub>OFF</sub>	V <sub>NO</sub> or V <sub>NC</sub> = 7V, R <sub>L</sub> = 2kΩ, C <sub>L</sub> = 35pF, Figure 2	+25°C	60	200		ns
			E		300		
Charge Injection (Note 7)	Q	C <sub>L</sub> = 1nF, V <sub>NO</sub> = 0, R <sub>S</sub> = 0Ω, Figure 3	+25°C		1	5	pC
NO or NC Off-Capacitance	C <sub>NO(OFF)</sub> , C <sub>NC(OFF)</sub>	f = 1MHz, Figure 4	+25°C		9		pF
COM Off-Capacitance	C <sub>COM(OFF)</sub>	V <sub>COM</sub> = 0, f = 1MHz, Figure 4	+25°C		9		pF
COM On-Capacitance	C <sub>COM(ON)</sub>	V <sub>COM</sub> = V <sub>NO</sub> = 0, f = 1MHz, Figure 4	+25°C		22		pF
Off-Isolation (Note 8)	V <sub>ISO</sub>	R <sub>L</sub> = 50Ω, C <sub>L</sub> = 15pF, V <sub>IN</sub> = 1V <sub>RMS</sub> , f = 1MHz, Figure 5	+25°C		-62		dB
<b>POWER SUPPLY</b>							
Power-Supply Range	V+		E	9		36	V
V+ Supply Current	I+	V <sub>IN</sub> = 0 or 5V	+25°C		50	125	μA
			E			175	
V- and GND Supply Current	I <sub>GND</sub>	V <sub>IN</sub> = 0 or 12V	+25°C		25	75	μA
			E			125	
		V <sub>IN</sub> = 0 or 5V	+25°C		50	125	μA
			E			175	

**Note 3:** Algebraic convention is used in this data sheet; the most negative value is shown in the minimum column.

**Note 4:** Leakage parameters are 100% tested at maximum-rated hot temperature and guaranteed by correlation at T<sub>A</sub> = +25°C.

**Note 5:** SOT packages are 100% tested at +25°C. Limits at the maximum-rated temperature are guaranteed by design and correlation limits at +25°C. Leakage tests for the SOT package are typical only.

**Note 6:** NC and NO pins are fault protected. Signals on NC or NO exceeding -36V to +36V may damage the device. These limits apply with power applied to V+ or V-, or ±40V with V+ = V- = 0.

**Note 7:** Guaranteed by design.

**Note 8:** Off isolation = 20log<sub>10</sub> [ V<sub>COM</sub> / (V<sub>NC</sub> or V<sub>NO</sub>) ], V<sub>COM</sub> = output, V<sub>NC</sub> or V<sub>NO</sub> = input to off switch.

**Note 9:** Leakage testing for single-supply operation is guaranteed by testing with dual supplies.

# Rail-to-Rail, Fault-Protected, SPST Analog Switches

## Typical Operating Characteristics

( $T_A = +25^\circ\text{C}$ , unless otherwise noted.)

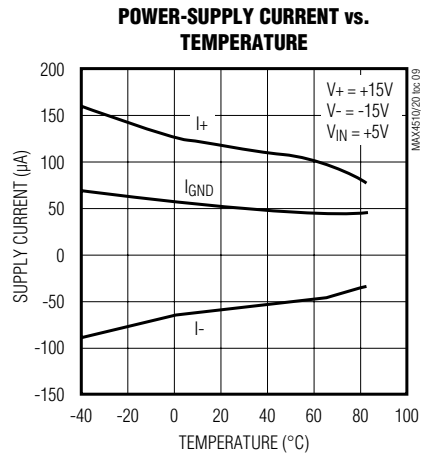
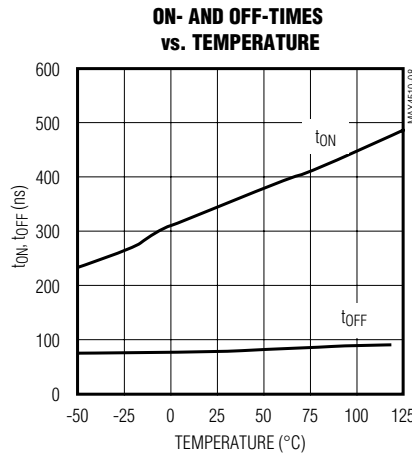
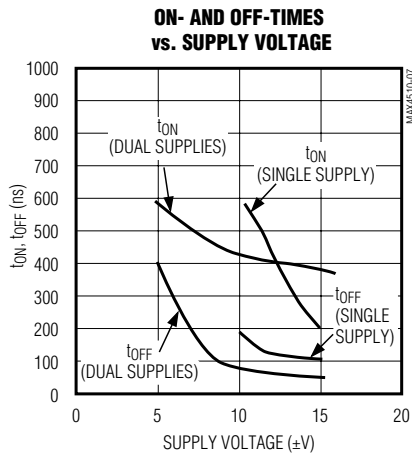
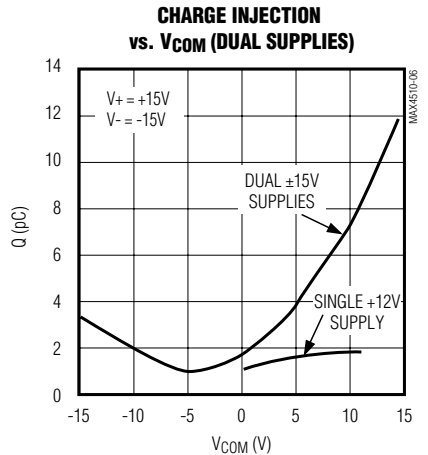
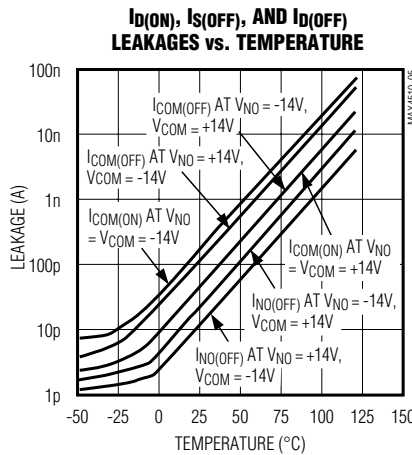
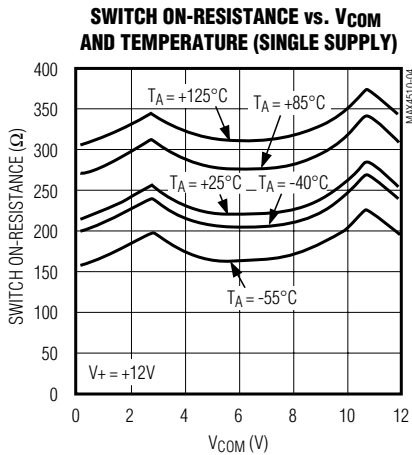
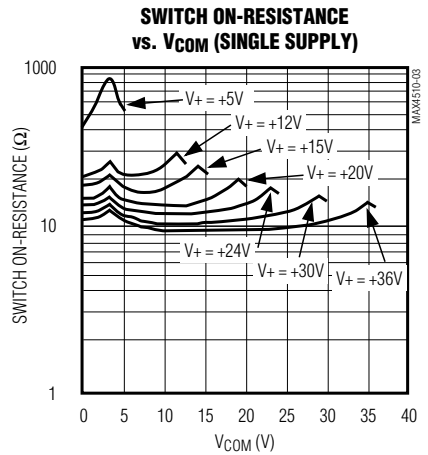
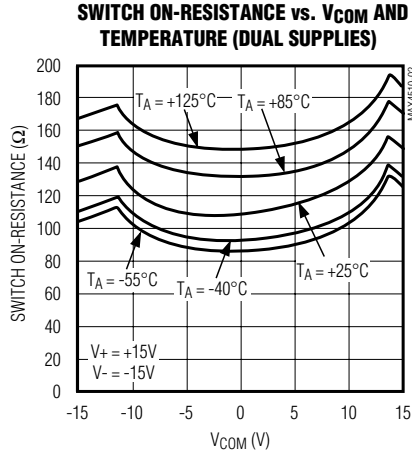
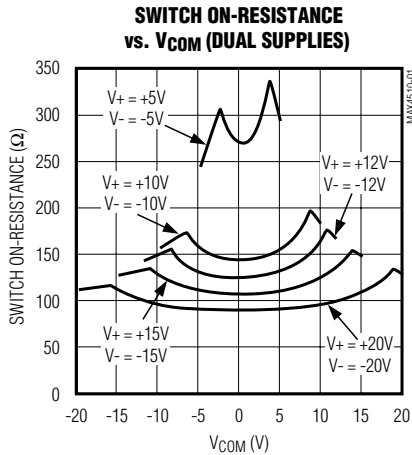

# Rail-to-Rail, Fault-Protected, SPST Analog Switches

MAX4510/MAX4520

## Typical Operating Characteristics (continued)

( $T_A = +25^\circ\text{C}$ , unless otherwise noted.)

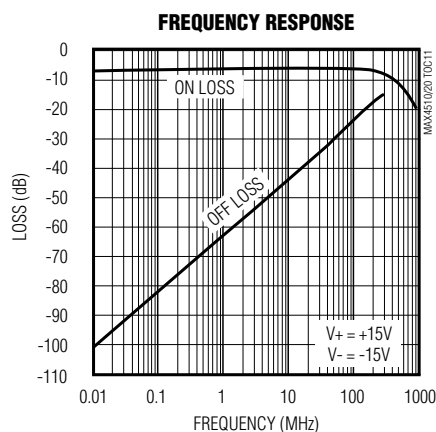
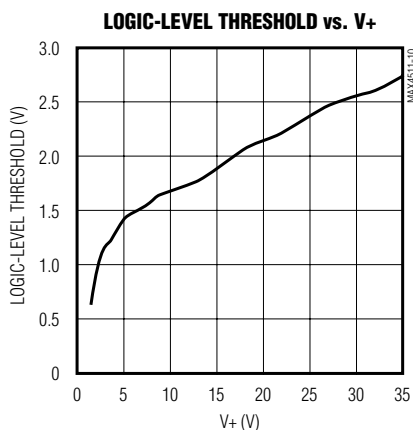

## Pin Description

PIN		NAME	FUNCTION
SOT23-6	$\mu\text{MAX}$		
1	8	$V_+$	Positive Supply Voltage Input
2	5	$V_-$	Negative Supply Voltage Input. Connect to GND for single-supply operation.
3	6	IN	Logic Control Digital Input
4	4	GND	Ground
5	1	COM	Analog Switch Common Terminal
6	3	NC or NO	Fault-Protected Analog Switch—normally closed (NC) for MAX4510; normally open (NO) for MAX4520
—	2, 7	N.C.	No Connection. Not internally connected.

## Detailed Description

### Overview of Traditional Fault-Protected Switches

The MAX4510/MAX4520 are fault-protected CMOS analog switches with unusual operation and construction. Traditional fault-protected switches are constructed by three series FETs. This produces good off characteristics, but fairly high on-resistance when the signals are within about 3V of each supply rail. As the voltage on one side of the switch approaches within about 3V of either supply rail (a fault condition), the switch impedance becomes higher, limiting the output signal range (on the protected side of the switch) to approximately 3V less than the appropriate polarity supply voltage.

During a fault condition, the output current that flows from the protected side of the switch into its load comes from the fault source on the other side of the switch. If the switch is open or the load is extremely high impedance, the input current will be very low. If the switch is on and the load is low impedance, enough current will flow from the source to maintain the load voltage at 3V less than the supply.

# Rail-to-Rail, Fault-Protected, SPST Analog Switches

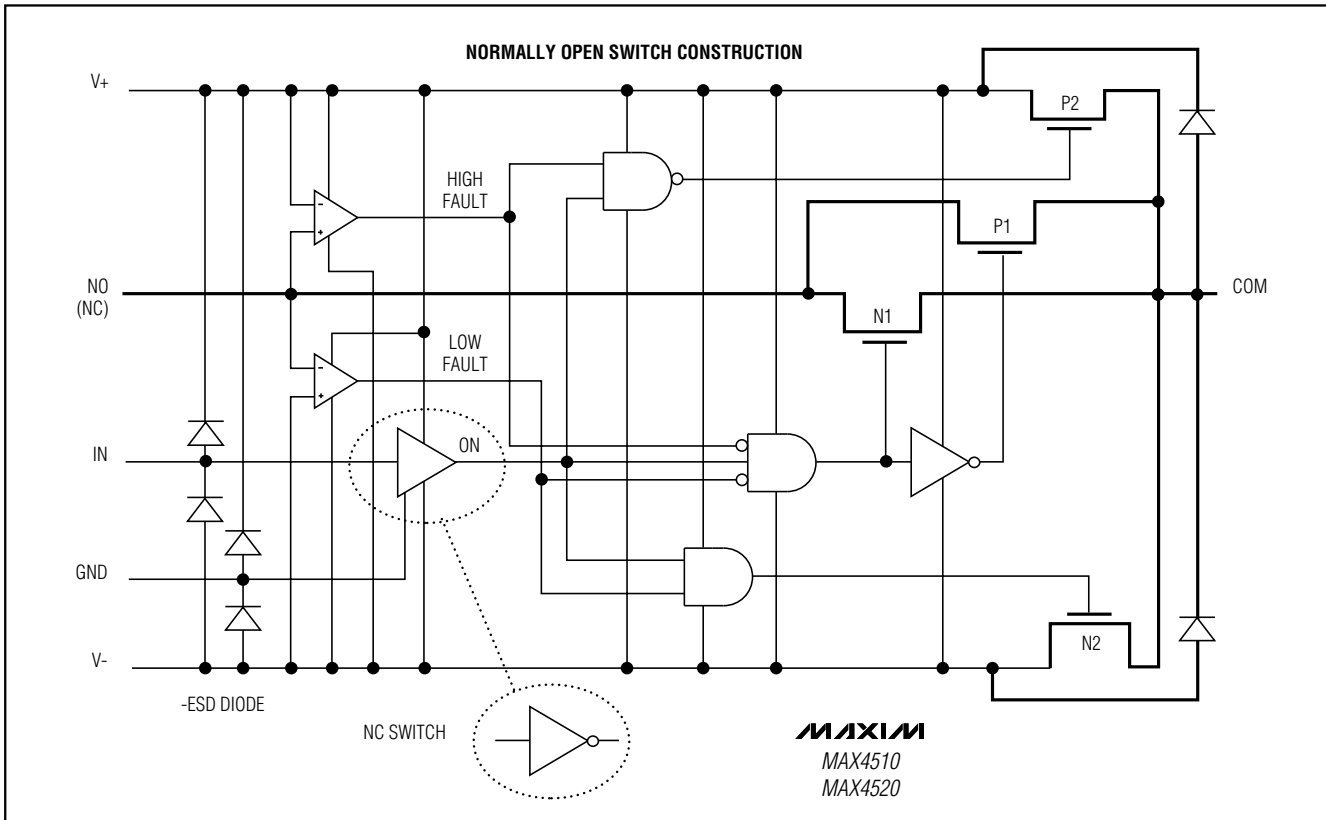

Figure 1. Functional Diagram

## Overview of MAX4510/MAX4520

The MAX4510/MAX4520 differ considerably from traditional fault-protection switches, with several advantages. First, they are constructed with two parallel FETs, allowing very low on-resistance when the switch is on. Second, they allow signals on the NC or NO pins that are within or slightly beyond the supply rails to be passed through the switch to the COM terminal, allowing rail-to-rail signal operation. Third, when a signal on NC or NO exceeds the supply rails by about 50mV (a fault condition), the voltage on COM is limited to the appropriate polarity supply voltage. Operation is identical for both fault polarities. The fault-protection extends to  $\pm 36V$  from GND.

During a fault condition, the NO or NC input pin becomes high impedance regardless of the switch state or load resistance. If the switch is on, the COM output current is furnished from the V+ or V- pin by "booster" FETs connected to each supply pin. These FETs can typically source or sink up to 13mA.

When power is removed, the fault protection is still in effect. In this case, the NO or NC terminals are a virtual open circuit. The fault can be up to  $\pm 40V$ .

The COM pin is not fault protected; it acts as a normal CMOS switch pin. If a voltage source is connected to the COM pin, it should be limited to the supply voltages. Exceeding the supply voltage will cause high currents to flow through the ESD protection diodes, possibly damaging the device (see *Absolute Maximum Ratings*).

## Internal Construction

Internal construction is shown in Figure 1, with the analog signal paths shown in bold. A single normally open (NO) switch is shown; the normally closed (NC) configuration is identical except the logic-level translator becomes an inverter. The analog switch is formed by the parallel combination of N-channel FET N1 and P-channel FET P1, which are driven on and off simultaneously according to the input fault condition and the logic-level state.



# Rail-to-Rail, Fault-Protected, SPST Analog Switches

MAX4510/MAX4520

## Normal Operation

Two comparators continuously compare the voltage on the NO (or NC) pin with V+ and V-. When the signal on NO or NC is between V+ and V-, the switch acts normally, with FETs N1 and P1 turning on and off in response to IN signals. The parallel combination of N1 and P1 forms a low-value resistor between NO (or NC) and COM so that signals pass equally well in either direction.

## Positive Fault Condition

When the signal on NO (or NC) exceeds V+ by about 50mV, the high-fault comparator output is high, turning off FETs N1 and P1. This makes the NO (or NC) pin high impedance regardless of the switch state. If the switch state is “off,” all FETs are turned off and both NO (or NC) and COM are high impedance. If the switch state is “on,” FET P2 is turned on, sourcing current from V+ to COM.

## Negative Fault Condition

When the signal on NO (or NC) exceeds V- by about 50mV, the low-fault comparator output is high, turning off FETs N1 and P1. This makes the NO (or NC) pin high impedance regardless of the switch state. If the switch state is “off,” all FETs are turned off and both NO (or NC) and COM are high impedance. If the switch state is “on,” FET N2 is turned on, sinking current from COM to V-.

## Transient Fault Response and Recovery

When a fast rise-time and fall-time transient on IN exceeds V+ or V-, the output (COM) follows the input (IN) to the supply rail with only a few nanoseconds delay. This delay is due to the switch on-resistance and circuit capacitance to ground. When the input transient returns to within the supply rails, however, there is a longer output recovery time delay. For positive faults, the recovery time is typically 3.5 $\mu$ s. For negative faults, the recovery time is typically 1.3 $\mu$ s. These values depend on the COM output resistance and capacitance. The delays are not dependent on the fault amplitude. Higher COM output resistance and capacitance increase recovery times.

## COM and IN Pins

FETs N2 and P2 can source about  $\pm 13$ mA from V+ or V- to the COM pin in the fault condition. Ensure that if the COM pin is connected to a low-resistance load, the absolute maximum current rating of 30mA is never exceeded, both in normal and fault conditions.

The GND, COM, and IN pins do not have fault protection. Reverse ESD-protection diodes are internally connected between GND, COM, IN, and both V+ and V-. If a signal on GND, COM, or IN exceeds V+ or V- by more

than 300mV, one of these diodes will conduct heavily. During normal operation these reverse-biased ESD diodes leak a few nanoamps of current to V+ and V-.

## Fault-Protection Voltage and Power Off

The maximum fault voltage on the NC or NO pins is  $\pm 36$ V with power applied and  $\pm 40$ V with power off.

## Failure Modes

The MAX4510/MAX4520 are not lightning arrestors or surge protectors.

Exceeding the fault-protection voltage limits on NO or NC, even for very short periods, can cause the device to fail.

## Ground

There is no connection between the analog signal path and GND. The analog signal path consists of an N-channel and P-channel MOSFET with their sources and drains paralleled and their gates driven out of phase to V+ and V- by the logic-level translators.

V+ and GND power the internal logic and logic-level translators and set the input logic thresholds. The logic-level translators convert the logic levels to switched V+ and V- signals to drive the gates of the analog switch. This drive signal is the only connection between the power supplies and the analog signal. GND, IN, and COM have ESD-protection diodes to V+ and V-.

## IN Logic-Level Thresholds

The logic-level thresholds are CMOS and TTL compatible when V+ is +15V. As V+ is raised, the threshold increases slightly, and when V+ reaches 25V, the level threshold is about 2.8V—above the TTL output high-level minimum of 2.4V, but still compatible with CMOS outputs (see *Typical Operating Characteristics*).

Increasing V- has no effect on the logic-level thresholds, but it does increase the gate-drive voltage to the signal FETs, reducing their on-resistance.

## Dual Supplies

The MAX4510/MAX4520 operate with dual supplies between  $\pm 4.5$ V and  $\pm 20$ V. The V+ and V- supplies need not be symmetrical, but their difference cannot exceed the absolute maximum rating of 44V.

## Single Supply

The MAX4510/MAX4520 operate from a single supply between +9V and +36V when V- is connected to GND.

# Rail-to-Rail, Fault-Protected, SPST Analog Switches

## Test Circuits/Timing Diagrams

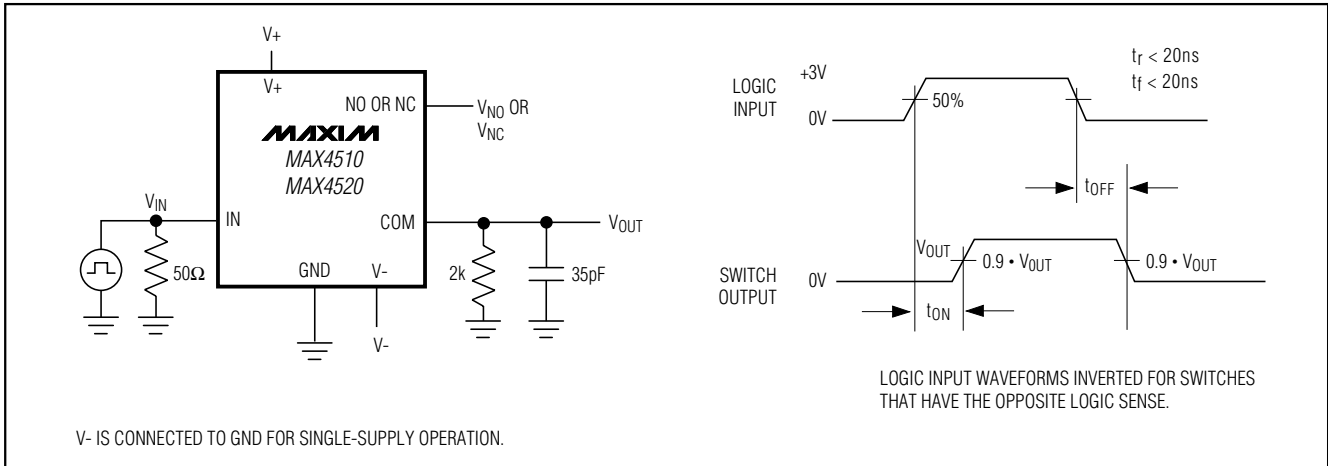

Figure 2. Switch Turn-On/Turn-Off Times

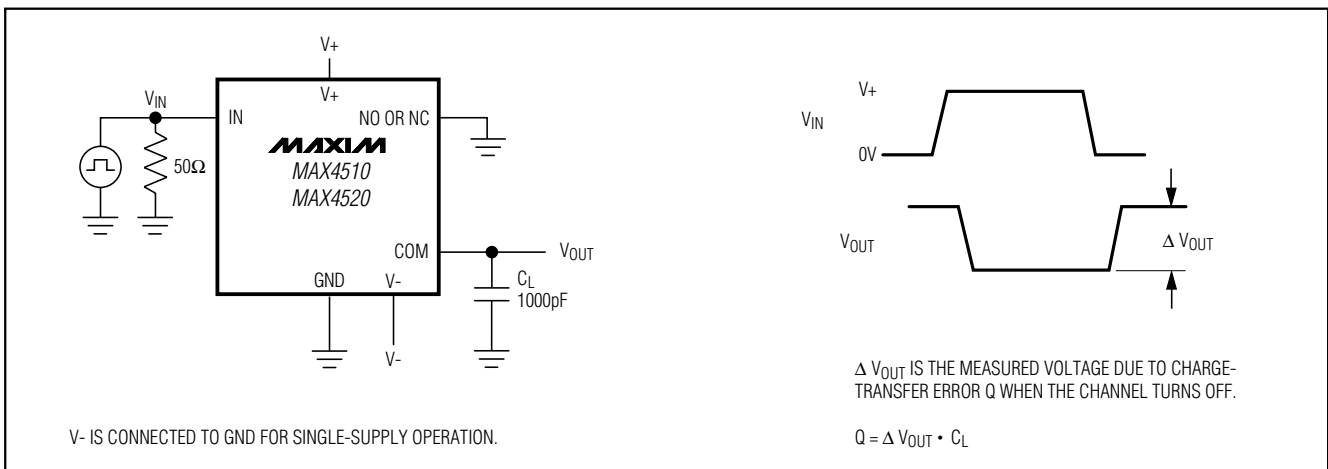

Figure 3. Charge Injection

# Rail-to-Rail, Fault-Protected, SPST Analog Switches

## Test Circuits/Timing Diagrams (continued)

**MAX4510/MAX4520**

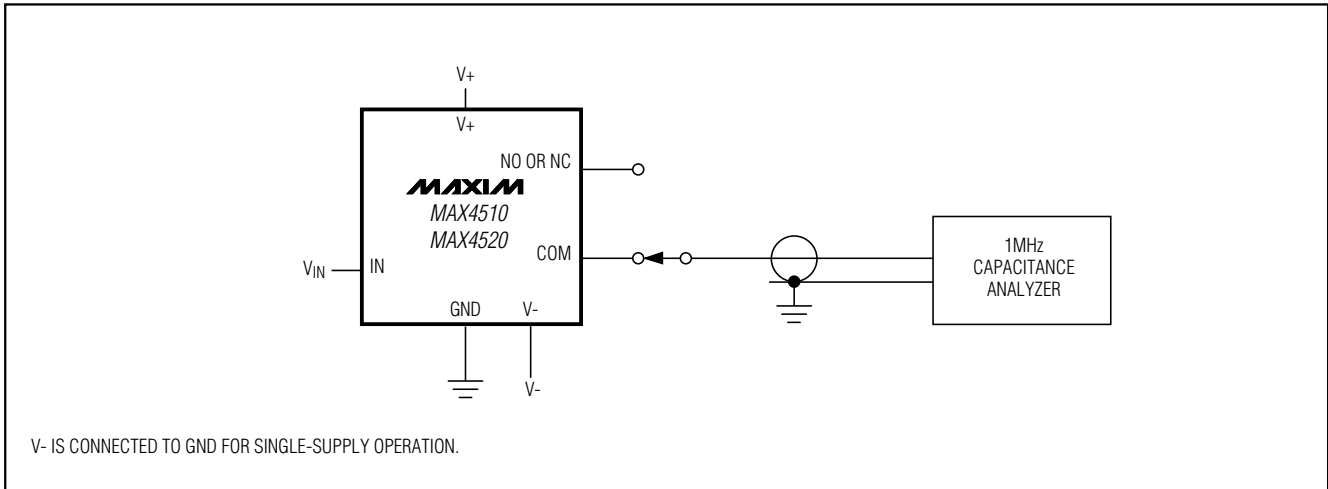

Figure 4. COM, NO, and NC Capacitance

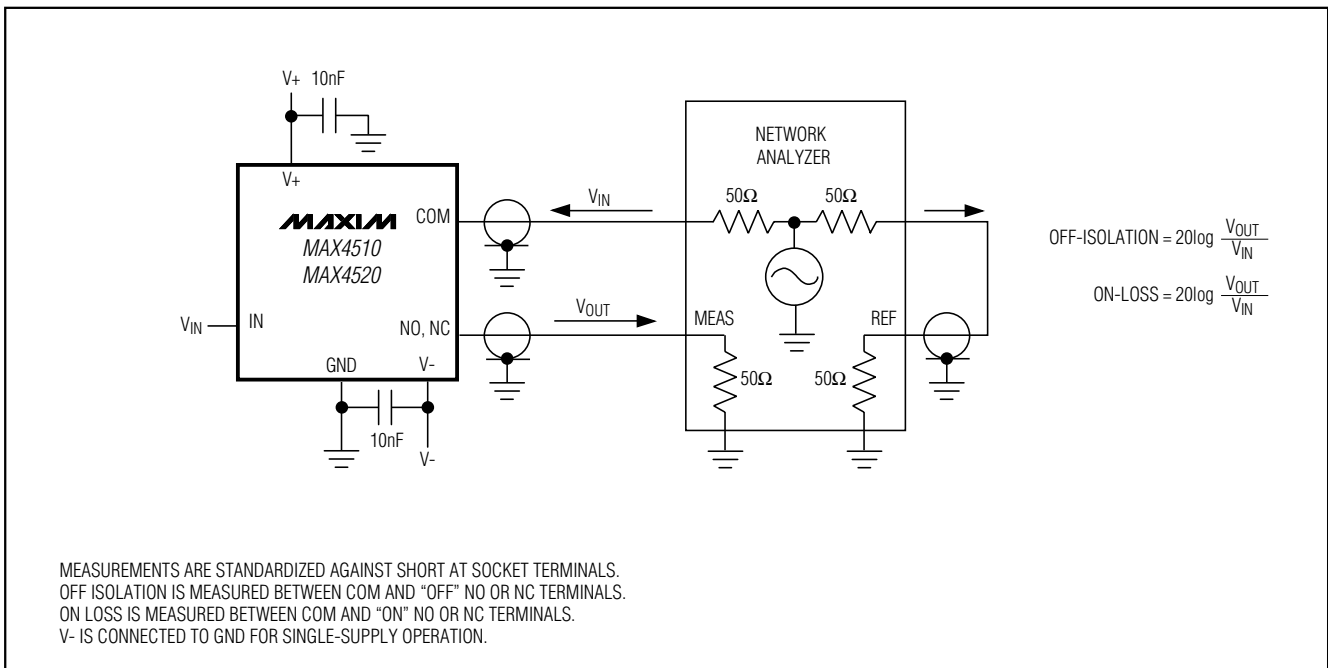

Figure 5. Frequency Response and Off-Isolation

## Chip Information

TRANSISTOR COUNT: 139

# Rail-to-Rail, Fault-Protected, SPST Analog Switches

## Pin Configurations/Functional Diagrams/Truth Tables (continued)

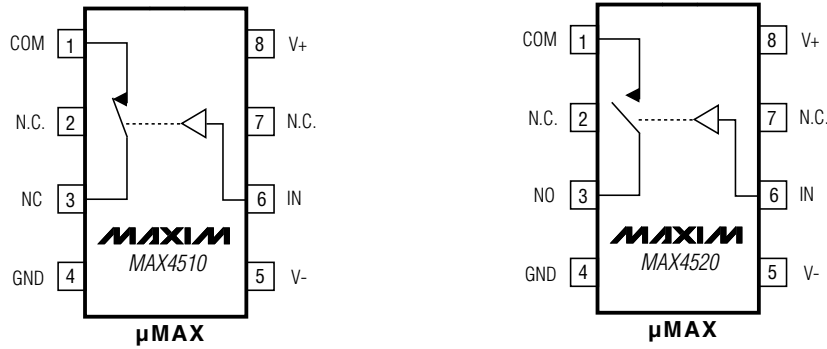

N.C. = NOT CONNECTED  
 SWITCHES SHOWN FOR LOGIC "0" INPUT.  
 ALL SWITCHES ARE OFF WITH POWER REMOVED.

IN	MAX4510	MAX4520
0	ON	OFF
1	OFF	ON

## Package Information

SYMBOL	MIN	MAX
A	0.90	1.45
A1	0.00	0.15
A2	0.90	1.30
b	0.35	0.50
C	0.08	0.20
D	2.80	3.00
E	2.60	3.00
E1	1.50	1.75
L	0.35	0.55
e	0.95 REF	
a	0°	10°

NOTE:

- ALL DIMENSIONS ARE IN MILLIMETERS.
- FOOT LENGTH MEASURED AT INTERCEPT POINT BETWEEN DATUM A & LEAD SURFACE.
- PACKAGE OUTLINE EXCLUSIVE OF MOLD FLASH & METAL BURR.
- PACKAGE OUTLINE INCLUSIVE OF SOLDER PLATING.
- PIN 1 IS LOWER LEFT PIN WHEN READING TOP MARK FROM LEFT TO RIGHT. (SEE EXAMPLE TOP MARK)
- PIN 1 I.D. DOT IS 0.3 MM Ø MIN. LOCATED ABOVE PIN 1.

<b>MAXIM</b>			
<small>PROPRIETARY INFORMATION</small>			
<small>TITLE</small>			
PACKAGE OUTLINE, SOT23, 6L			
<small>APPROVAL</small>	<small>DOCUMENT CONTROL NO.</small>	<small>REV</small>	<small>D</small>
	21-0058	D	1/1

EUSOT23P

Maxim cannot assume responsibility for use of any circuitry other than circuitry entirely embodied in a Maxim product. No circuit patent licenses are implied. Maxim reserves the right to change the circuitry and specifications without notice at any time.

12 **Maxim Integrated Products, 120 San Gabriel Drive, Sunnyvale, CA 94086 408-737-7600**

Copyright © Each Manufacturing Company.

All Datasheets cannot be modified without permission.

This datasheet has been download from :

[www.AllDataSheet.com](http://www.AllDataSheet.com)

100% Free DataSheet Search Site.

Free Download.

No Register.

Fast Search System.

[www.AllDataSheet.com](http://www.AllDataSheet.com)