

9-Bit Latch TTL/ECL Translator

The MC10H/100H602 is a 9-bit, dual supply TTL to ECL translator with latch. Devices in the Motorola 9-bit translator series utilize the 28-lead PLCC for optimal power pinning, signal flow-through and electrical performance.

The H602 features D-type latches. Latching is controlled by Latch Enable (LEN), while the Master Reset input resets the latches. A post-latch logic enable is also provided (ENECL), allowing control of the output state without destroying latch data. All control inputs are ECL level.

The 10H version is compatible with MECL 10H ECL logic levels. The 100H version is compatible with 100K levels.

- 9-Bit Ideal for Byte-Parity Applications
- Flow-Through Configuration
- Extra TTL and ECL Power/Ground Pins to Minimize Switching Noise
- Dual Supply
- 3.5 ns Max D to Q
- PNP TTL Inputs for Low Loading

LOGIC SYMBOL

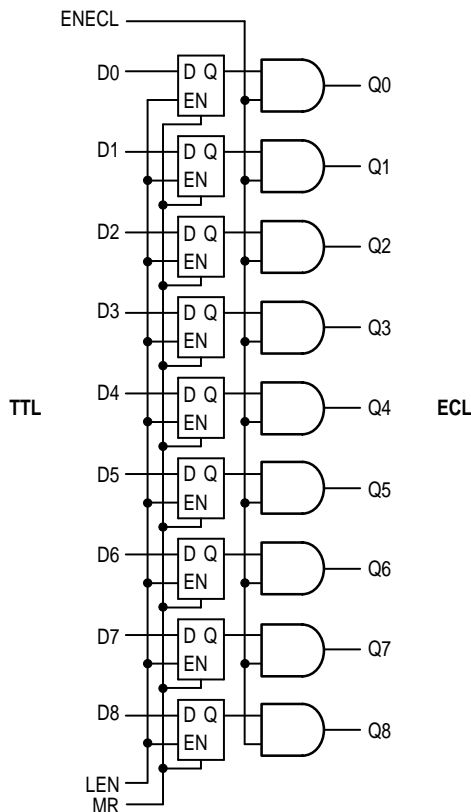

MC10H602 MC100H602

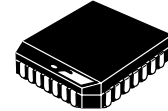

FN SUFFIX
PLASTIC PACKAGE
CASE 776-02

PIN NAMES

PIN	FUNCTION
GND	TTL Ground (0 V)
V _{CCE}	ECL V _{CC} (0 V)
V _{CCO}	ECL V _{CC} (0 V) — Outputs
V _{CCT}	TTL Supply (+5.0 V)
V _{EE}	ECL Supply (-5.2/-4.5 V)
D0-D8	Data Inputs (TTL)
Q0-Q8	Data Outputs (ECL)
ENECL	Enable Control (ECL)
LEN	Latch Enable (ECL)
MR	Master Reset (ECL)

TRUTH TABLE

D	LEN	MR	ENECL	Q
L	L	L	H	L
H	L	L	H	H
X	H	L	H	Q ₀
X	X	H	H	L
X	X	X	L	L

Pinout: 28-Lead PLCC (Top View)

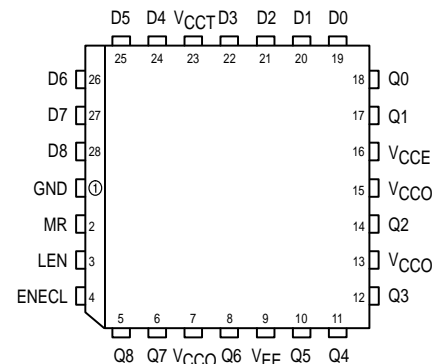

MC10H602 MC100H602

DC CHARACTERISTICS: $V_{CCT} = 5.0\text{ V} \pm 10\%$; $V_{EE} = -5.2\text{ V} \pm 5\%$ (10H version); $V_{EE} = -4.2\text{ V to } -5.5\text{ V}$ (100H version)

Symbol	Parameter		0°C		25°C		75°C		Unit	Condition
			Min	Max	Min	Max	Min	Max		
	Power Supply Current									
I_{EE}	ECL	10H 100H		-125 -122		-125 -123		-125 -132	mA	
I_{CCH} I_{CCL}	TTL			48 50		48 50		48 50	mA	

AC CHARACTERISTICS: $V_{CCT} = 5.0\text{ V} \pm 10\%$; $V_{EE} = -5.2\text{ V} \pm 5\%$ (10H version); $V_{EE} = -4.2\text{ V to } -5.5\text{ V}$ (100H version)

Symbol	Parameter		0°C		25°C		75°C		Unit	Condition
			Min	Max	Min	Max	Min	Max		
t_{PLH} t_{PHL}	Propagation Delay to Output	D	1.4	3.0	1.5	3.2	1.7	3.5	ns	
		LEN	2.0	3.4	2.1	3.5	2.4	3.7		
		MR	2.0	3.4	2.1	3.5	2.5	3.9		
		ENECL	1.6	3.2	1.7	3.3	1.8	3.7		
t_s	Set-Up Time, D to LEN		2.0		2.0		2.0		ns	
t_h	Hold Time, D to LEN		1.0		1.0		1.0		ns	
$t_{w(L)}$	LEN Pulse Width, LOW		2.0		2.0		2.0		ns	
t_R t_F	Output Rise/Fall Time 20%–80%		0.5	1.5	0.5	1.5	0.5	1.5	ns	

10H ECL DC CHARACTERISTICS: $V_{CCT} = 5.0\text{ V} \pm 10\%$; $V_{EE} = -5.2\text{ V} \pm 5\%$

Symbol	Parameter		0°C		25°C		75°C		Unit	Condition
			Min	Max	Min	Max	Min	Max		
I_{IH} I_{IL}	Input HIGH Current Input LOW Current		0.5	225	0.5	145	0.5	145	μA μA	
V_{IH} V_{IL}	Input HIGH Voltage Input LOW Voltage		-1170 -1950	-840 -1480	-1130 -1950	-810 -1480	-1070 -1950	-735 -1450	mV	
V_{OH} V_{OL}	Output HIGH Voltage Output LOW Voltage		-1020 -1950	-840 -1630	-980 -1950	-810 -1630	-920 -1950	-735 -1600	mV	50 Ω to -2.0 V

100H ECL DC CHARACTERISTICS: $V_{CCT} = 5.0\text{ V} \pm 10\%$; $V_{EE} = -4.2\text{ V to } -5.5\text{ V}$

Symbol	Parameter		0°C		25°C		75°C		Unit	Condition
			Min	Max	Min	Max	Min	Max		
I_{IH} I_{IL}	Input HIGH Current Input LOW Current		0.5	225	0.5	145	0.5	145	μA μA	
V_{IH} V_{IL}	Input HIGH Voltage Input LOW Voltage		-1165 -1810	-880 -1475	-1165 -1810	-880 -1475	-1165 -1810	-880 -1475	mV	
V_{OH} V_{OL}	Output HIGH Voltage Output LOW Voltage		-1025 -1810	-880 -1620	-1025 -1810	-880 -1620	-1025 -1810	-880 -1620	mV	50 Ω to -2.0 V

TTL DC CHARACTERISTICS: $V_{CCT} = 5.0\text{ V} \pm 10\%$; $V_{EE} = -5.2\text{ V} \pm 5\%$ (10H version); $V_{EE} = -4.2\text{ V to } -5.5\text{ V}$ (100H version)

Symbol	Parameter		0°C		25°C		75°C		Unit	Condition
			Min	Max	Min	Max	Min	Max		
V_{IH} V_{IL}	Input HIGH Voltage Input LOW Voltage		2.0	0.8	2.0	0.8	2.0	0.8	V V	
I_{IH}	Input HIGH Current			20 100		20 100		20 100	μA	$V_{IN} = 2.7\text{ V}$ $V_{IN} = 7.0\text{ V}$
I_{IL}	Input LOW Current			-0.6		-0.6		-0.6	mA	$V_{IN} = 0.5\text{ V}$
V_{IK}	Input Clamp Voltage			-1.2		-1.2		-1.2	V	$I_{IN} = -18\text{ mA}$

OUTLINE DIMENSIONS

FN SUFFIX
PLASTIC PLCC PACKAGE
CASE 776-02
ISSUE D

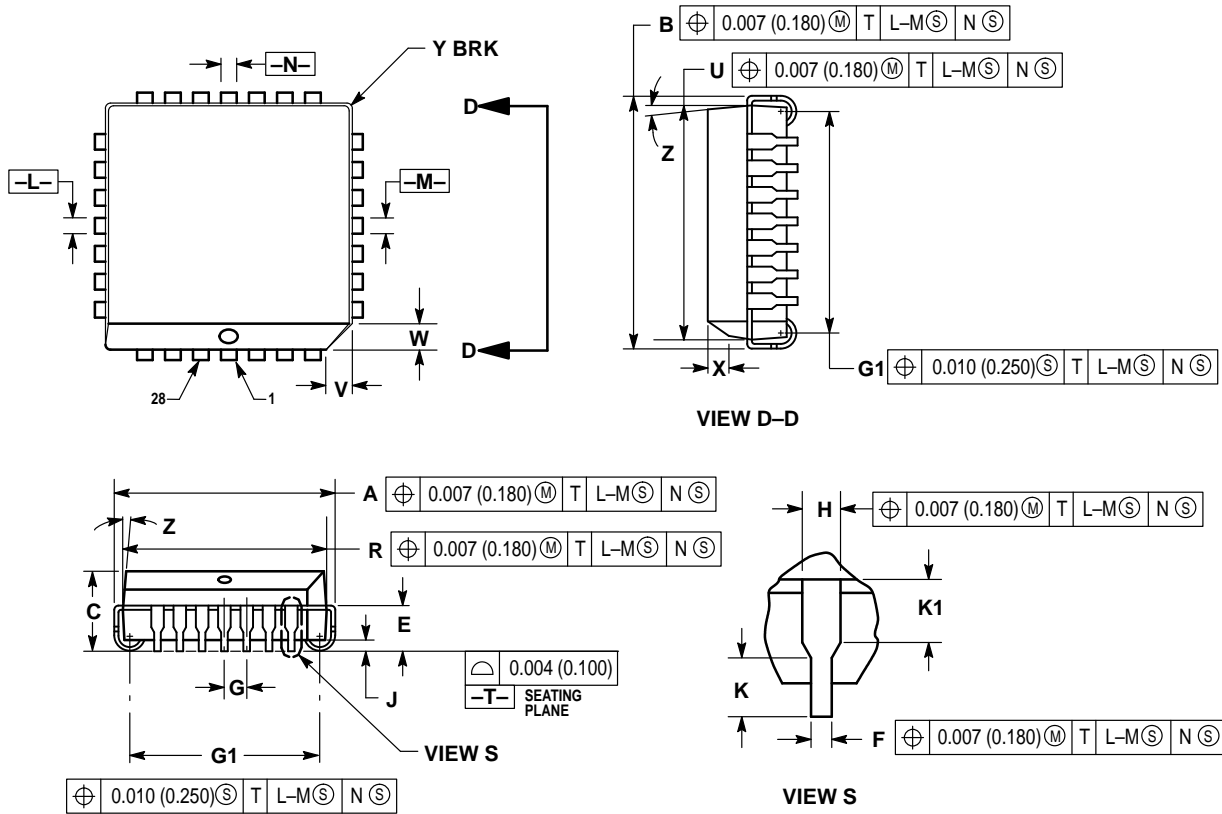

NOTES:

- DATUMS -L-, -M-, AND -N- DETERMINED WHERE TOP OF LEAD SHOULDER EXITS PLASTIC BODY AT MOLD PARTING LINE.
- DIMENSION G1, TRUE POSITION TO BE MEASURED AT DATUM -T-, SEATING PLANE.
- DIMENSIONS R AND U DO NOT INCLUDE MOLD FLASH. ALLOWABLE MOLD FLASH IS 0.010 (0.250) PER SIDE.
- DIMENSIONING AND TOLERANCING PER ANSI Y14.5M, 1982.
- CONTROLLING DIMENSION: INCH.
- THE PACKAGE TOP MAY BE SMALLER THAN THE PACKAGE BOTTOM BY UP TO 0.012 (0.300). DIMENSIONS R AND U ARE DETERMINED AT THE OUTERMOST EXTREMES OF THE PLASTIC BODY EXCLUSIVE OF MOLD FLASH, TIE BAR BURRS, GATE BURRS AND INTERLEAD FLASH, BUT INCLUDING ANY MISMATCH BETWEEN THE TOP AND BOTTOM OF THE PLASTIC BODY.
- DIMENSION H DOES NOT INCLUDE DAMBAR PROTRUSION OR INTRUSION. THE DAMBAR PROTRUSION(S) SHALL NOT CAUSE THE H DIMENSION TO BE GREATER THAN 0.037 (0.940). THE DAMBAR INTRUSION(S) SHALL NOT CAUSE THE H DIMENSION TO BE SMALLER THAN 0.025 (0.635).

DIM	INCHES		MILLIMETERS	
	MIN	MAX	MIN	MAX
A	0.485	0.495	12.32	12.57
B	0.485	0.495	12.32	12.57
C	0.165	0.180	4.20	4.57
E	0.090	0.110	2.29	2.79
F	0.013	0.019	0.33	0.48
G	0.050 BSC		1.27 BSC	
H	0.026	0.032	0.66	0.81
J	0.020	—	0.51	—
K	0.025	—	0.64	—
R	0.450	0.456	11.43	11.58
U	0.450	0.456	11.43	11.58
V	0.042	0.048	1.07	1.21
W	0.042	0.048	1.07	1.21
X	0.042	0.056	1.07	1.42
Y	—	0.020	—	0.50
Z	2° 10°		2° 10°	
G1	0.410	0.430	10.42	10.92
K1	0.040	—	1.02	—

Motorola reserves the right to make changes without further notice to any products herein. Motorola makes no warranty, representation or guarantee regarding the suitability of its products for any particular purpose, nor does Motorola assume any liability arising out of the application or use of any product or circuit, and specifically disclaims any and all liability, including without limitation consequential or incidental damages. "Typical" parameters which may be provided in Motorola data sheets and/or specifications can and do vary in different applications and actual performance may vary over time. All operating parameters, including "Typicals" must be validated for each customer application by customer's technical experts. Motorola does not convey any license under its patent rights nor the rights of others. Motorola products are not designed, intended, or authorized for use as components in systems intended for surgical implant into the body, or other applications intended to support or sustain life, or for any other application in which the failure of the Motorola product could create a situation where personal injury or death may occur. Should Buyer purchase or use Motorola products for any such unintended or unauthorized application, Buyer shall indemnify and hold Motorola and its officers, employees, subsidiaries, affiliates, and distributors harmless against all claims, costs, damages, and expenses, and reasonable attorney fees arising out of, directly or indirectly, any claim of personal injury or death associated with such unintended or unauthorized use, even if such claim alleges that Motorola was negligent regarding the design or manufacture of the part. Motorola and  are registered trademarks of Motorola, Inc. Motorola, Inc. is an Equal Opportunity/Affirmative Action Employer.

How to reach us:

USA/EUROPE/Locations Not Listed: Motorola Literature Distribution;
P.O. Box 20912; Phoenix, Arizona 85036. 1-800-441-2447 or 602-303-5454

MFAX: RMFAX0@email.sps.mot.com – TOUCHTONE 602-244-6609
INTERNET: <http://Design-NET.com>

JAPAN: Nippon Motorola Ltd.; Tatsumi-SPD-JLDC, 6F Seibu-Butsuryu-Center,
3-14-2 Tatsumi Koto-Ku, Tokyo 135, Japan. 03-81-3521-8315

ASIA/PACIFIC: Motorola Semiconductors H.K. Ltd.; 8B Tai Ping Industrial Park,
51 Ting Kok Road, Tai Po, N.T., Hong Kong. 852-26629298



Copyright © Each Manufacturing Company.

All Datasheets cannot be modified without permission.

This datasheet has been download from :

www.AllDataSheet.com

100% Free DataSheet Search Site.

Free Download.

No Register.

Fast Search System.

www.AllDataSheet.com