

**FEATURES**

- 9-bit ideal for byte-parity applications
- Flow-through configuration
- Extra TTL and ECL power/ground pins to minimize switching noise
- Dual supply
- 3.5ns max. D to Q
- PNP TTL inputs for low loading
- Choice of ECL compatibility: MECL 10KH (10Hxxx) or 100K (100Hxxx)
- Fully compatible with Motorola MC10H/100H602
- Available in 28-pin PLCC package

**DESCRIPTION**

The SY10/100H602 are 9-bit, dual supply TTL-to-ECL translators with latches. Devices in the Micrel-Synergy 9-bit translator series utilize the 28-lead PLCC for optimal power pinning, signal flow-through and electrical performance.

The H602 features D-type latches. Latching is controlled by Latch Enable (LEN), while the Master Reset input resets the latches. A post-latch logic enable is also provided (ENECL), allowing control of the output state without destroying latch data. All control inputs are ECL level.

The 10H version is compatible with MECL 10KH ECL logic levels. The 100H version is compatible with 100K levels.

**BLOCK DIAGRAM**

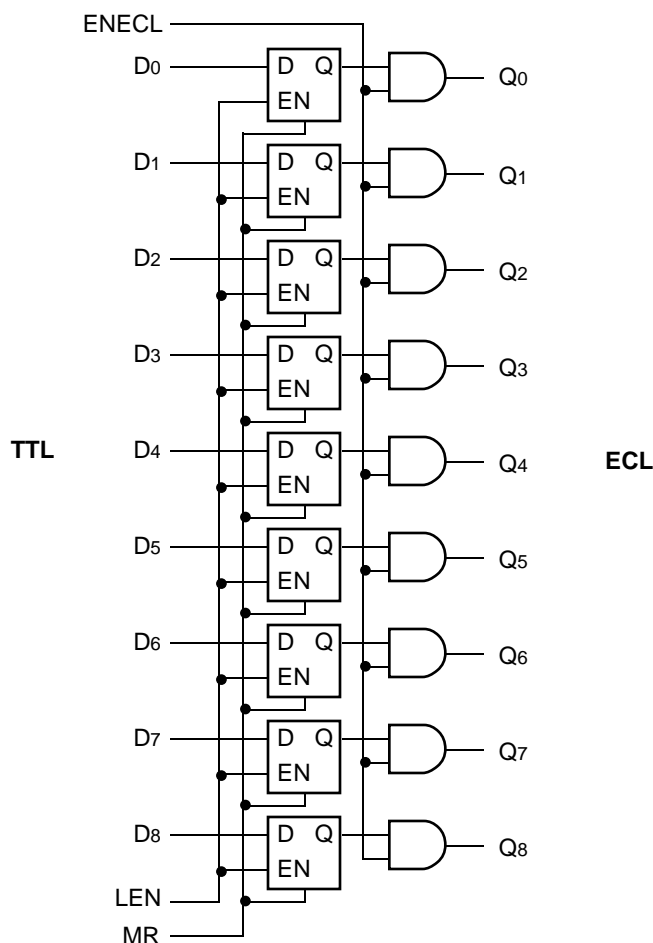

**PIN CONFIGURATION**

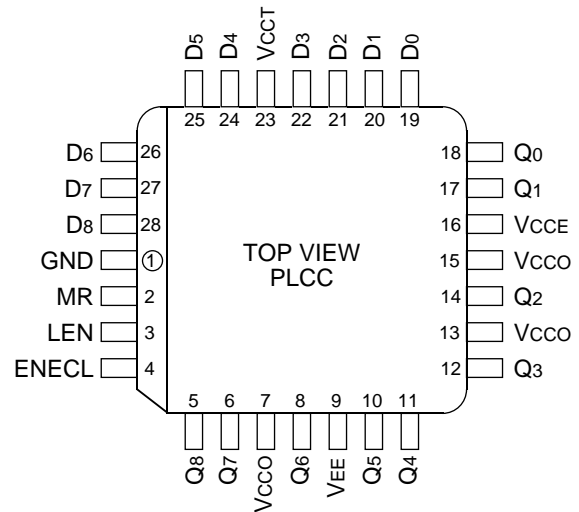

**PIN NAMES**

Pin	Function
GND	TTL Ground (0V)
VCCO	ECL Vcc (0V)
VCCO	ECL Vcc (0V) — Outputs
VCCT	TTL Supply (+5.0V)
VEE	ECL Supply (-5.2/-4.5V)
D0-D8	Data Inputs (TTL)
Q0-Q8	Data Outputs (ECL)
ENECL	Enable Control (ECL)
LEN	Latch Enable (ECL)
MR	Master Reset (ECL)

**TRUTH TABLE**

D	LEN	MR	ENECL	Q
L	L	L	H	L
H	L	L	H	H
X	H	L	H	Q <sub>0</sub>
X	X	H	H	L
X	X	X	L	L

**DC ELECTRICAL CHARACTERISTICS**

V<sub>CC</sub>T = 5.0V ± 10%; V<sub>EE</sub> = -4.75V to -5.5V (10H Version); V<sub>EE</sub> = -4.2V to -5.5V (100H Version)

Symbol	Parameter	T <sub>A</sub> = 0°C		T <sub>A</sub> = +25°C		T <sub>A</sub> = +85°C		Unit	Condition
		Min.	Max.	Min.	Max.	Min.	Max.		
I <sub>EE</sub>	Power Supply Current, ECL 10H 100H	—	125	—	125	—	125	mA	—
		—	122	—	123	—	132		
I <sub>CCH</sub> I <sub>CCL</sub>	Power Supply Current, TTL	—	48	—	48	—	48	mA	—
		—	50	—	50	—	50		

**AC ELECTRICAL CHARACTERISTICS**

V<sub>CC</sub>T = 5.0V ± 10%; V<sub>EE</sub> = -4.75V to -5.5V (10H Version); V<sub>EE</sub> = -4.2V to -5.5V (100H Version)

Symbol	Parameter	T <sub>A</sub> = 0°C		T <sub>A</sub> = +25°C		T <sub>A</sub> = +85°C		Unit	Condition		
		Min.	Max.	Min.	Max.	Min.	Max.				
t <sub>PLH</sub> t <sub>PHL</sub>	Propagation Delay to Output D LEN MR ENECL	1.4 2.0 2.0 1.6	3.0 3.4 3.4 3.2	1.5 2.1 2.1 1.7	3.2 3.5 3.5 3.3	1.7 2.4 2.5 1.8	3.5 3.7 3.9 3.7	ns	—		
t <sub>s</sub>	Set-up Time, D to LEN	2.0	—	2.0	—	2.0	—			ns	—
t <sub>H</sub>	Hold Time, D to LEN	1.0	—	1.0	—	1.0	—			ns	—
t <sub>w(L)</sub>	LEN Pulse Width, LOW	2.0	—	2.0	—	2.0	—			ns	—
t <sub>r</sub> t <sub>f</sub>	Output Rise/Fall Time 20% to 80%, 80% to 20%	0.5	1.5	0.5	1.5	0.5	1.5	ns	—		

**PRODUCT ORDERING CODE**

Ordering Code	Package Type	Operating Range
SY10H602JC	J28-1	Commercial
SY10H602JCTR	J28-1	Commercial
SY100H602JC	J28-1	Commercial
SY100H602JCTR	J28-1	Commercial

**28 LEAD PLCC (J28-1)**

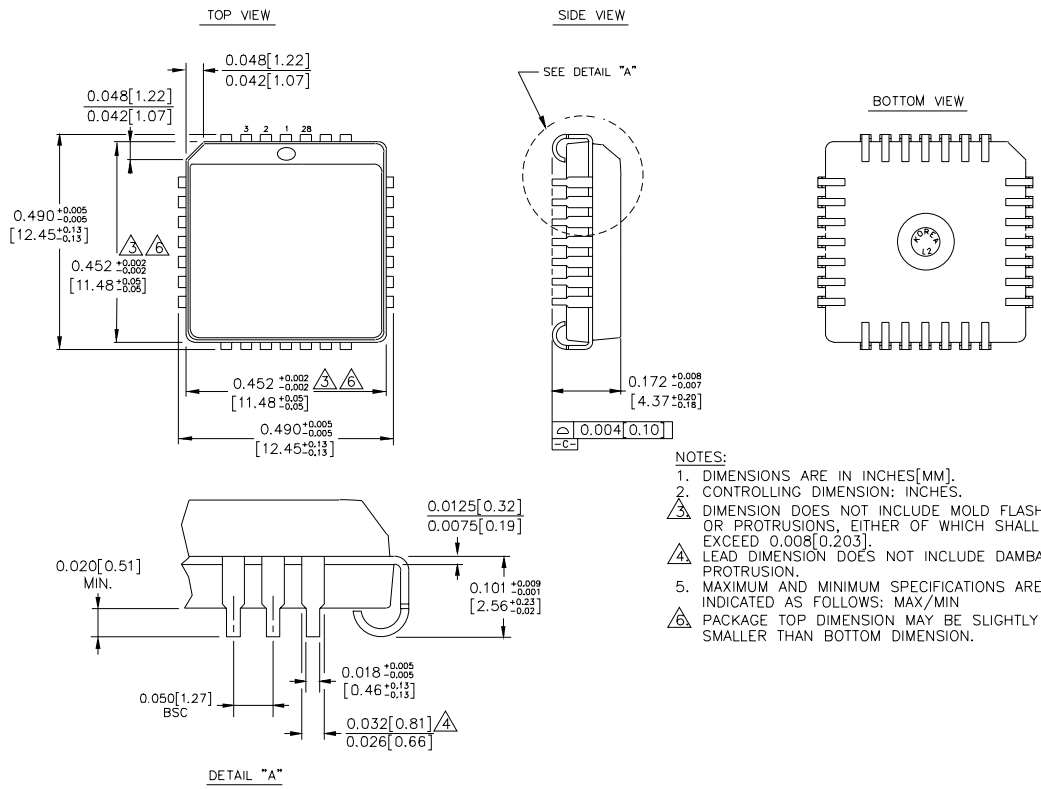

- NOTES:**
1. DIMENSIONS ARE IN INCHES[MM].
  2. CONTROLLING DIMENSION: INCHES.
  3. DIMENSION DOES NOT INCLUDE MOLD FLASH OR PROTRUSIONS, EITHER OF WHICH SHALL NOT EXCEED 0.008[0.203].
  4. LEAD DIMENSION DOES NOT INCLUDE DAMBAR PROTRUSION.
  5. MAXIMUM AND MINIMUM SPECIFICATIONS ARE INDICATED AS FOLLOWS: MAX/MIN
  6. PACKAGE TOP DIMENSION MAY BE SLIGHTLY SMALLER THAN BOTTOM DIMENSION.

Rev. 03

---

**MICREL-SYNERGY 3250 SCOTT BOULEVARD SANTA CLARA CA 95054 USA**

TEL + 1 (408) 980-9191 FAX + 1 (408) 914-7878 WEB <http://www.micrel.com>

This information is believed to be accurate and reliable, however no responsibility is assumed by Micrel for its use nor for any infringement of patents or other rights of third parties resulting from its use. No license is granted by implication or otherwise under any patent or patent right of Micrel Inc.

© 2000 Micrel Incorporated

---

Copyright Each Manufacturing Company.

All Datasheets cannot be modified without permission.

This datasheet has been download from :

[www.AllDataSheet.com](http://www.AllDataSheet.com)

100% Free DataSheet Search Site.

Free Download.

No Register.

Fast Search System.

[www.AllDataSheet.com](http://www.AllDataSheet.com)