

- Structure Silicon Monolithic Integrated Circuit
- Product Series 4ch Sensorless System Motor Driver for MD
- Type **BD6640KUT**
- Features
- Operates at low power supply voltage (2.1V min)
 - Power DMOS output with low ON resistance (0.8Ω Typ.)
 - Incorporates a charge pump circuit for VG boost.
 - 3-phase full-wave soft-switching sensorless driver for spindle
 - 3-value control 3-phase driver for sled (built-in comparator for BEMF voltage detection)
 - 2ch, 3-value control H-bridges for focus/tracking
 - PWM half-bridge for spindle VM power supply

○Absolute maximum ratings(Ta=25°C)

Parameter	Symbol	Limit	Unit
Power supply voltage for control circuit	VCC	7	V
Power supply voltage for driver block	VM	7	V
Power supply voltage for pre-driver block	VG	14	V
Input voltage	VIN	0~VCC	V
Output current	Iomax	*500	mA
Power dissipation	Pd	**1375	mW
Operating temperature range	Topr	-25~+75	°C
Storage temperature range	Tstg	-55~+150	°C
Junction temperature	Tjmax	+150	°C

* Must not exceed Pd or ASO, Tjmax=150°C.

* * Reduced by 11mW/°C over Ta=25°C, when mounted on a glass epoxy board (70mm×70 mm×1.6mm).

○Operating conditions (Ta=-25~+75°C)

Parameter	Symbol	Min.	Typ.	Max	Unit
Power supply voltage	VCC1,2	2.1	2.2	6.5	V
	VM	-	-	5.0	V
	VG	3	6.5	13	V
Pulse input frequency	fin	-	-	500	kHz

This product described in this specification is not judged whether it applies to COCOM regulations.

Please confirm in case of export.

This product is not designed for protection against radioactive rays.

○Electrical characteristics

(Unless otherwise specified, Ta=25°C, VCC1, 2=2.2V, VM=1.0V, fin=176kHz)

Parameter	Symbol	Limit			Unit	Conditions
		Min.	Typ.	Max.		
Circuit current	ICC	-	4.4	7.0	mA	at operation in all blocks
	IST	-	1	10	μA	at standby in all blocks
Output ON resistance	RON	-	0.8	1.2	Ω	upper and lower ON resistance in total VG=10V
~Boost circuit~						
Output voltage	VG1	5.5	6.5	6.7	V	each input L
	VG2	4.4	5.2	-	V	at operation in all blocks
~Oscillation circuit~						
Self-propelled oscillating frequency	fOSC	50	100	160	kHz	
External clock synchronous range	fSYNC	-	-	500	kHz	input from EXTCLK pin
~Spindle (3-phase full-wave sensorless driver) block~						
Position detection comparator	VCO	-10	-	+10	mV	
Detection comparator input range	VCD	0	-	VCC-	V	
CST charge current	ICTO	-3.5	-2.1	-0.9	μA	CST=1V
CST discharge current	ICTI	1.0	3.6	7.5	mA	CST=1V
CSL charge current	ICLO	-3.5	-7.5	-13	μA	CSL=0.5V
CSL discharge current	ICLI	1.2	3.0	6.5	μA	CSL=0.5V
CSL clamp H voltage	VCLH	0.7	0.8	0.9	V	
Brake comparator input current	IBR	-	-	2.0	μA	BRK=VCC
Brake comparator input offset	VBO	-15	-	+15	mV	
Brake comparator input range	VBD	0	-	VCC-1	V	
FG output pull-up resistance	RBF	10	20	30	kΩ	
FG output L voltage	VOLF	-	0.2	0.3	V	Io=300μA
RIB offset voltage	VRO	10	18	30	mV	VM=0V RIB=500Ω
Pre-drive loop gain	VRP	500	650	850	mV	
M-phase check	VMCK	400	500	600	mV	
~Sled, focus, tracking, PWM power supply (stepping, H-bridge, and half-bridge driver) block~						
Logic H level input voltage	VINH	VCC-0.4	-	VCC	V	
Logic L level input voltage	VINL	0	-	0.4	V	
Logic H level input current	IINH1	-	-	1	μA	VIN=2.2V
	IINH2	-	350	600	μA	VIN=2.2V EXTCLK pin
Logic L level input current	IINL	-1	-	-	μA	VIN=0V
Output propagation delay time	TRISE	-	0.2	1	μsec	
	TFALL	-	0.1	0.7	μsec	
Short pulse response	tmin	120	-	-	nsec	input pulse width 200 ns

©This product is not designed for protection against radioactive rays.

○Package outlines

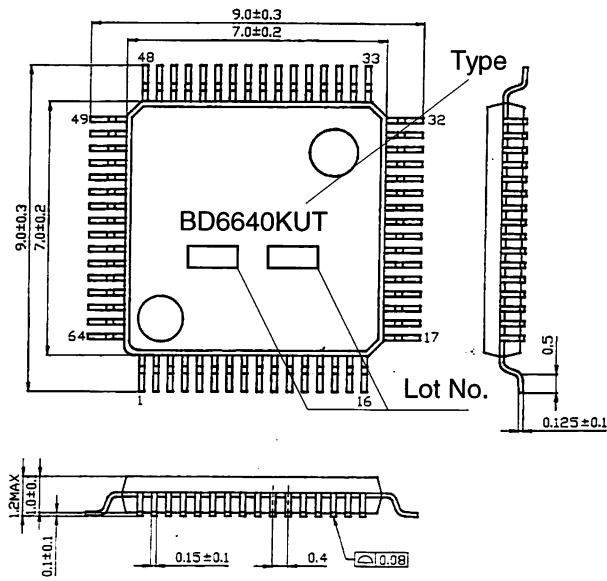

TQFP64U outlines (Unit : mm)

○Block diagram

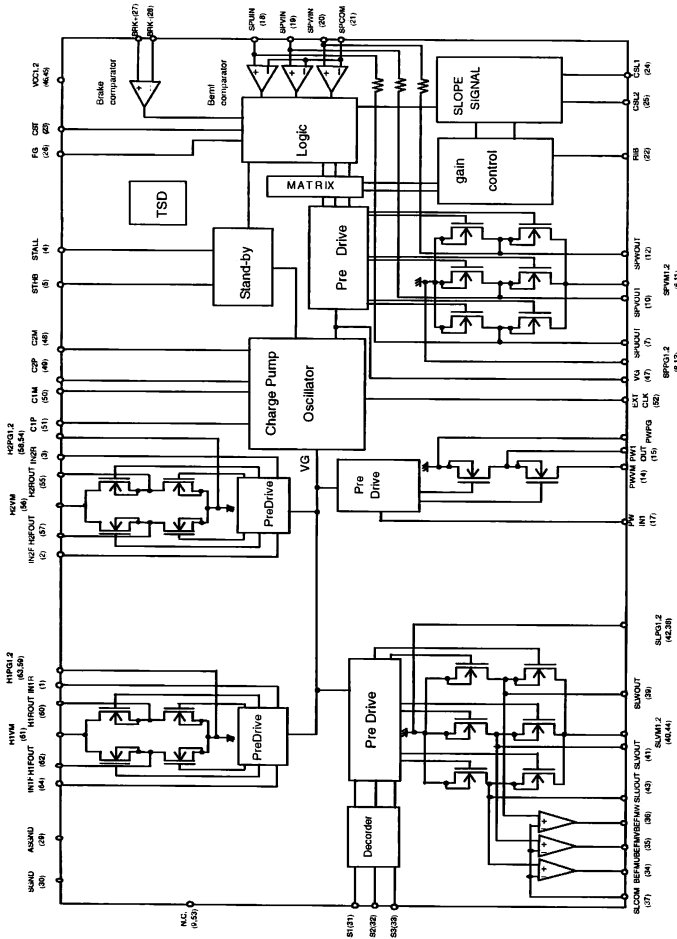

○Pin No./Pin name

NO.	Pin name	NO.	Pin name
1	IN1R	33	S3
2	IN2F	34	BEMFU
3	IN2R	35	BEMFV
4	STALL	36	BEMFW
5	STHB	37	SLCOM
6	SPVM1	38	SLPG2
7	SPUOUT	39	SLWOUT
8	SPPG1	40	SLVM2
9	N.C.	41	SLVOUT
10	SPVOUT	42	SLPG1
11	SPVM2	43	SLUOUT
12	SPWOUT	44	SLVM1
13	SPPG2	45	VCC2
14	PWVM	46	VCC1
15	PWOUT	47	VG
16	PWPG	48	C2M
17	PWIN1	49	C2P
18	SPUIN	50	C1M
19	SPVIN	51	C1P
20	SPWIN	52	EXTCLK
21	SPCOM	53	N.C.
22	RIB	54	H2PG2
23	CST	55	H2ROUT
24	CSL1	56	H2VM
25	CSL2	57	H2FOUT
26	FG	58	H2PG1
27	BRK+	59	H1PG2
28	BRK-	60	H1ROUT
29	ASGND	61	H1VM
30	SGND	62	H1FOUT
31	S1	63	H1PG1
32	S2	64	IN1F

○Notes on the use

- (1) Absolute maximum ratings
If the input voltage or the operating temperature range exceeds absolute maximum ratings, IC may be damaged. No destruction mode (e.g., short-circuiting or open) can be specified in that case. If such special mode as will exceed absolute maximum ratings is assumed, take the physical safety measures, such as a fuse.
- (2) Power supply lines
The regenerated current by BEMF of the motor will return. Therefore, take measures, such as the insertion of a capacitor between the power supply and GND as the pass of the regenerated current. Determine the capacitance in full consideration of all the characteristics of the electrolytic capacitor, because the electrolytic capacitor may loose some capacitance at low temperatures.
- (3) Ground potential
Ensure a minimum GND pin potential in all operating conditions.
- (4) Design for heat
Use the design for heat that allows for a sufficient margin in light of the power dissipation (Pd) in actual using conditions.
- (5) Operation in strong magnetic field
Use caution when using the IC in the strong magnetic field as doing so may cause the IC to malfunction.
- (6) ASO
When using the IC, make settings so that the output transistors for the motor will not be used under conditions in excess of the absolute maximum ratings and ASO.
- (7) Thermal shutdown circuit
This IC incorporates thermal shutdown circuit(TSD circuit).
When the chip temperature becomes the one shown in below, TSD circuit operates and makes the coil output to motor open. It is designed to shut the IC off from runaway thermal operation. It is not designed to protect the IC or guarantee its operation. Do not continue to use the IC after operating this circuit or use the IC in an environment where the operation of this circuit is assumed.

TSD ON temperature[°C] (typ.)	Hysteresis temperature [°C] (typ.)
175	20

- (8) Ground wiring pattern
When having both small signal and large current GND, it is recommended to isolate the two GND patterns, placing a single ground point at the application's reference point so that the pattern wiring resistance and voltage variations caused by large currents do not cause voltage variations of the small signal GND. Be careful not to change the GND wiring pattern of any external parts, either.

Notes

- No technical content pages of this document may be reproduced in any form or transmitted by any means without prior permission of ROHM CO.,LTD.
- The contents described herein are subject to change without notice. The specifications for the product described in this document are for reference only. Upon actual use, therefore, please request that specifications to be separately delivered.
- Application circuit diagrams and circuit constants contained herein are shown as examples of standard use and operation. Please pay careful attention to the peripheral conditions when designing circuits and deciding upon circuit constants in the set.
- Any data, including, but not limited to application circuit diagrams information, described herein are intended only as illustrations of such devices and not as the specifications for such devices. ROHM CO.,LTD. disclaims any warranty that any use of such devices shall be free from infringement of any third party's intellectual property rights or other proprietary rights, and further, assumes no liability of whatsoever nature in the event of any such infringement, or arising from or connected with or related to the use of such devices.
- Upon the sale of any such devices, other than for buyer's right to use such devices itself, resell or otherwise dispose of the same, no express or implied right or license to practice or commercially exploit any intellectual property rights or other proprietary rights owned or controlled by
- ROHM CO., LTD. is granted to any such buyer.
- Products listed in this document are no antiradiation design.

The products listed in this document are designed to be used with ordinary electronic equipment or devices (such as audio visual equipment, office-automation equipment, communications devices, electrical appliances and electronic toys).

Should you intend to use these products with equipment or devices which require an extremely high level of reliability and the malfunction of which would directly endanger human life (such as medical instruments, transportation equipment, aerospace machinery, nuclear-reactor controllers, fuel controllers and other safety devices), please be sure to consult with our sales representative in advance.

About Export Control Order in Japan

Products described herein are the objects of controlled goods in Annex 1 (Item 16) of Export Trade Control Order in Japan.

In case of export from Japan, please confirm if it applies to "objective" criteria or an "informed" (by MITI clause) on the basis of "catch all controls for Non-Proliferation of Weapons of Mass Destruction.

Thank you for your accessing to ROHM product informations.
More detail product informations and catalogs are available,
please contact your nearest sales office.

Please contact our sales offices for details ;

U.S.A / San Diego	TEL : +1(858)625-3630	FAX : +1(858)625-3670
Atlanta	TEL : +1(770)754-5972	FAX : +1(770)754-0691
Dallas	TEL : +1(972)312-8818	FAX : +1(972)312-0330
Germany / Dusseldorf	TEL : +49(2154)9210	FAX : +49(2154)921400
United Kingdom / London	TEL : +44(1)908-282-666	FAX : +44(1)908-282-528
France / Paris	TEL : +33(0)1 56 97 30 60	FAX : +33(0) 1 56 97 30 80
China / Hong Kong	TEL : +852(2)740-6262	FAX : +852(2)375-8971
Shanghai	TEL : +86(21)6279-2727	FAX : +86(21)6247-2066
Dilian	TEL : +86(411)8230-8549	FAX : +86(411)8230-8537
Beijing	TEL : +86(10)8525-2483	FAX : +86(10)8525-2489
Taiwan / Taipei	TEL : +866(2)2500-6956	FAX : +866(2)2503-2869
Korea / Seoul	TEL : +82(2)8182-700	FAX : +82(2)8182-715
Singapore	TEL : +65-6332-2322	FAX : +65-6332-5662
Malaysia / Kuala Lumpur	TEL : +60(3)7958-8355	FAX : +60(3)7958-8377
Philippines / Manila	TEL : +63(2)807-6872	FAX : +63(2)809-1422
Thailand / Bangkok	TEL : +66(2)254-4890	FAX : +66(2)256-6334

Japan /
(Internal Sales)

Tokyo	2-1-1, Yaesu, Chuo-ku, Tokyo 104-0082	TEL : +81(3)5203-0321	FAX : +81(3)5203-0300
Yokohama	2-4-8, Shin Yokohama, Kohoku-ku, Yokohama, Kanagawa 222-8575	TEL : +81(45)476-2131	FAX : +81(45)476-2128
Nagoya	Dainagayo Building 9F 3-28-12, Meieki, Nakamura-ku, Nagoya, Aichi 450-0002	TEL : +81(52)581-8521	FAX : +81(52)561-2173
Kyoto	579-32 Higashi Shiokouji-cho, Karasuma Nishi-iru, Shiokoujidori, Shimogyo-ku, Kyoto 600-8216	TEL : +81(75)311-2121	FAX : +81(75)314-6559

(Contact address for overseas customers in Japan)

Yokohama	TEL : +81(45)476-9270	FAX : +81(045)476-9271
----------	-----------------------	------------------------