



MX27C8100

8M-BIT [1M x8/512K x16] CMOS OTP ROM

FEATURES

- 1M x 8 or 512K x 16 organization
- +12.5V programming voltage
- Fast access time: 100/120/150/200 ns
- Totally static operation
- Completely TTL compatible

- Operating current: 60mA
- Standby current: 100uA
- Package type:
 - 42 pin plastic DIP
 - 44 pin SOP

GENERAL DESCRIPTION

The MX27C8100 is a 5V only, 8M-bit, One Time Programmable Read Only Memory. It is organized as 1M x 8 or 512K x 16, operates from a single + 5 volt supply, has a static standby mode, and features fast single address location programming. All programming signals are TTL levels, requiring a single pulse. For programming outside from the system, existing EPROM programmers may be

used. The MX27C8100 supports a intelligent fast programming algorithm which can result in programming time of less than two minutes.

This One Time Programmable Read Only Memory is packaged in industry standard 42 pin dual-in-line plastic package and 44 pin SOP packages.

PIN CONFIGURATIONS

PDIP

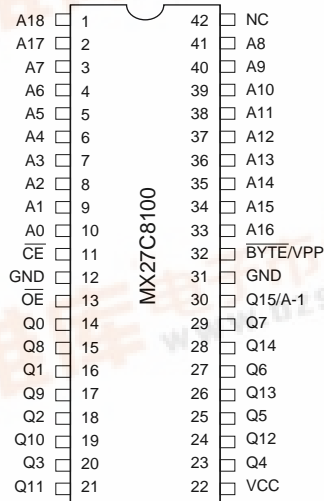

SOP

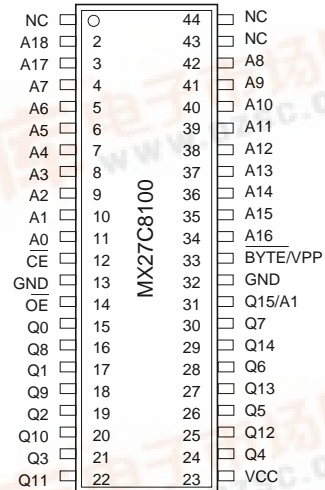

BLOCK DIAGRAM

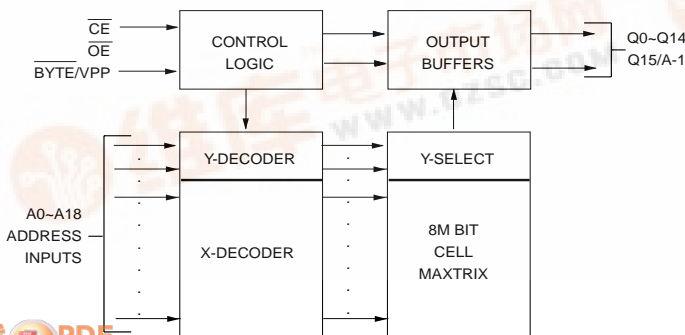



PIN DESCRIPTION

SYMBOL	PIN NAME
A0~A18	Address Input
Q0~Q14	Data Input/Output
\overline{CE}	Chip Enable Input
\overline{OE}	Output Enable Input
\overline{BYTE}/VPP	Word/Byte Selection/Program Supply Voltage
Q15/A-1	Q15(Word mode)/LSB addr. (Byte mode)
VCC	Power Supply Pin (+5V)
GND	Ground Pin

TRUTH TABLE OF \overline{BYTE} FUNCTION

BYTE MODE($\overline{BYTE} = GND$)

\overline{CE}	\overline{OE}	Q15/A-1	MODE	Q0-Q7	SUPPLY CURRENT
H	X	X	Non selected	High Z	Standby(ICC2)
L	H	X	Non selected	High Z	Operating(ICC1)
L	L	A-1 input	Selected	DOUT	Operating(ICC1)

WORD MODE($\overline{BYTE} = VCC$)

\overline{CE}	\overline{OE}	Q15/A-1	MODE	Q0-Q14	SUPPLY CURRENT
H	X	High Z	Non selected	High Z	Standby(ICC2)
L	H	High Z	Non selected	High Z	Operating(ICC1)
L	L	DOUT	Selected	DOUT	Operating(ICC1)

NOTE : X = H or L



FUNCTIONAL DESCRIPTION

THE PROGRAMMING OF THE MX27C8100

When the MX27C8100 is delivered, the chip has all 8M bits in the "ONE" or HIGH state. "ZEROS" are loaded into the MX27C8100 through the procedure of programming.

For programming, the data to be programmed is applied with 16 bits in parallel to the data pins.

V_{cc} must be applied simultaneously or before V_{pp}, and removed simultaneously or after V_{pp}. When programming an MXIC One Time Programmable Read Only Memory, a 0.1uF capacitor is required across V_{pp} and ground to suppress spurious voltage transients which may damage the device.

FAST PROGRAMMING

The device is set up in the fast programming mode when the programming voltage V_{PP} = 12.75V is applied, with V_{CC} = 6.25 V and OE = VIH (Algorithm is shown in Figure 1). The programming is achieved by applying a single TTL low level 50us pulse to the CE input after addresses and data line are stable. If the data is not verified, an additional pulse is applied for a maximum of 25 pulses. This process is repeated while sequencing through each address of the device. When the programming mode is completed, the data in all address is verified at V_{CC} = V_{PP} = 5V ± 10%.

PROGRAM INHIBIT MODE

Programming of multiple MX27C8100's in parallel with different data is also easily accomplished by using the Program Inhibit Mode. Except for CE and OE, all like inputs of the parallel MX27C8100 may be common. A TTL low-level program pulse applied to an MX27C8100 CE input with V_{PP} = 12.5 ± 0.5 V will program the MX27C8100. A high-level CE input inhibits the other MX27C8100 from being programmed.

PROGRAM VERIFY MODE

Verification should be performed on the programmed bits to determine that they were correctly programmed. The verification should be performed with OE at VIL, CE at VIH, and V_{PP} at its programming voltage.

AUTO IDENTIFY MODE

The auto identify mode allows the reading out of a binary code from an One Time Programmable Read Only Memory that will identify its manufacturer and device type. This mode is intended for use by programming equipment for the purpose of automatically matching the device to be programmed with its corresponding programming algorithm. This mode is functional in the 25°C ± 5°C ambient temperature range that is required when programming the MX27C8100.

To activate this mode, the programming equipment must force 12.0 ± 0.5 V on address line A9 of the device. Two identifier bytes may then be sequenced from the device outputs by toggling address line A0 from VIL to VIH. All other address lines must be held at VIL during auto identify mode.

Byte 0 (A0 = VIL) represents the manufacturer code, and byte 1 (A0 = VIH), the device identifier code. For the MX27C8100, these two identifier bytes are given in the Mode Select Table. All identifiers for manufacturer and device codes will possess odd parity, with the MSB (Q15) defined as the parity bit.

READ MODE

The MX27C8100 has two control functions, both of which must be logically satisfied in order to obtain data at the outputs. Chip Enable (CE) is the power control and should be used for device selection. Output Enable (OE) is the output control and should be used to gate data to the output pins, independent of device selection. Assuming that addresses are stable, address access time (t_{ACC}) is equal to the delay from CE to output (t_{CE}). Data is available at the outputs t_{OE} after the falling edge of OE's, assuming that CE has been LOW and addresses have been stable for at least t_{ACC} - t_{OE}.

WORD-WIDE MODE

With BYTE/V_{PP} at V_{CC} ± 0.2V outputs Q0-7 present data Q0-7 and outputs Q8-15 present data Q8-15, after CE and OE are appropriately enabled.



BYTE-WIDE MODE

With BYTE/VPP at GND ± 0.2V, outputs Q8-15 are tri-stated. If Q15/A-1 = VIH, outputs Q0-7 present data bits Q8-15. If Q15/A-1 = VIL, outputs Q0-7 present data bits Q0-7.

STANDBY MODE

The MX27C8100 has a CMOS standby mode which reduces the maximum VCC current to 100 uA. It is placed in CMOS standby when CE is at VCC ± 0.3V. The MX27C8100 also has a TTL-standby mode which reduces the maximum VCC current to 1.5 mA. It is placed in TTL-standby when CE is at VIH. When in standby mode, the outputs are in a high-impedance state, independent of the OE input.

TWO-LINE OUTPUT CONTROL FUNCTION

To accommodate multiple memory connections, a two-line control function is provided to allow for:

1. Low memory power dissipation,
2. Assurance that output bus contention will not occur.

It is recommended that CE be decoded and used as the primary device-selecting function, while OE be made a common connection to all devices in the array and connected to the READ line from the system control bus. This assures that all deselected memory devices are in their low-power standby mode and that the output pins are only active when data is desired from a particular memory device.

SYSTEM CONSIDERATIONS

During the switch between active and standby conditions, transient current peaks are produced on the rising and falling edges of Chip Enable. The magnitude of these transient current peaks is dependent on the output capacitance loading of the device. At a minimum, a 0.1 uF ceramic capacitor (high frequency, low inherent inductance) should be used on each device between Vcc and GND to minimize transient effects. In addition, to overcome the voltage drop caused by the inductive effects of the printed circuit board traces on One Time Programmable Read Only Memory arrays, a 4.7 uF bulk electrolytic capacitor should be used between VCC and GND for each eight devices. The location of the capacitor should be close to where the power supply is connected to the array.

MODE SELECT TABLE

MODE	CE	OE	A9	A0	BYTE/			
					Q15/A-1	VPP(5)	Q8-14	Q0-7
Read (Word)	VIL	VIL	X	X	Q15 Out	VCC	Q8-14 Out	Q0-7 Out
Read (Upper Byte)	VIL	VIL	X	X	VIH	GND	High Z	Q8-15 Out
Read (Lower Byte)	VIL	VIL	X	X	VIL	GND	High Z	Q0-7 Out
Output Disable	VIL	VIH	X	X	High Z	X	High Z	High Z
Standby	VIH	X	X	X	High Z	X	High Z	High Z
Program	VIL	VIH	X	X	Q15 In	VPP	Q8-14 In	Q0-7 In
Program Verify	VIH	VIL	X	X	Q15 Out	VPP	Q8-14 Out	Q0-7 Out
Program Inhibit	VIH	VIH	X	X	High Z	VPP	High Z	High Z
Manufacturer Code(3)	VIL	VIL	VH	VIL	0B	VCC	00H	C2H
Device Code(3)	VIL	VIL	VH	VIH	1B	VCC	38H	16H

NOTES:

1. VH = 12.0V ± 0.5V
2. X Either VIL or VIH.
3. A1 - A8, A10 - A18 = VIL (for auto select)
4. See DC Programming Characteristics for VPP voltages.
5. BYTE/VPP is intended for operation under DC Voltage conditions only.
6. Manufacture code = 00C2H
Device code = B816H

FIGURE 1. FAST PROGRAMMING FLOW CHART

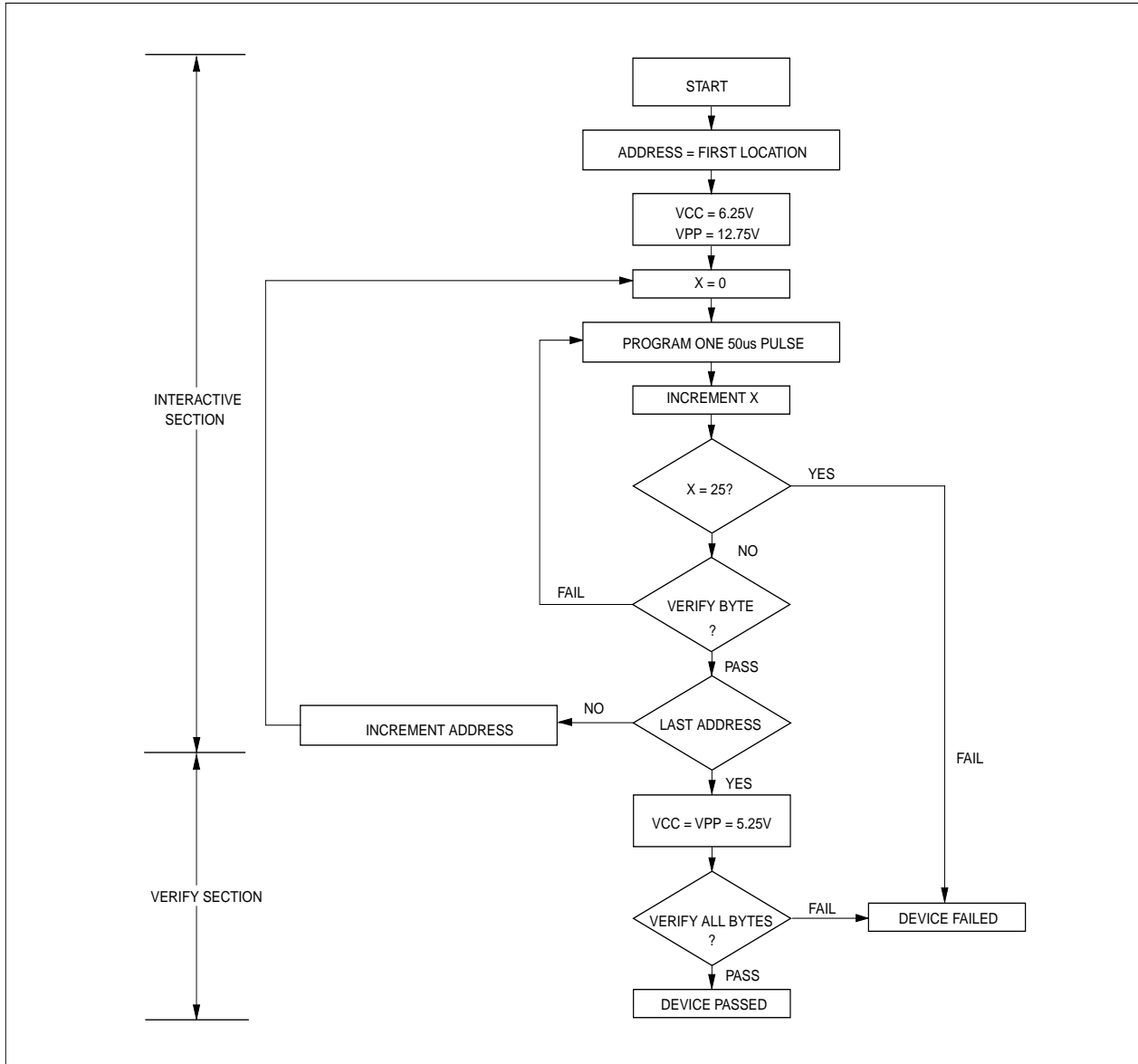

SWITCHING TEST CIRCUITS

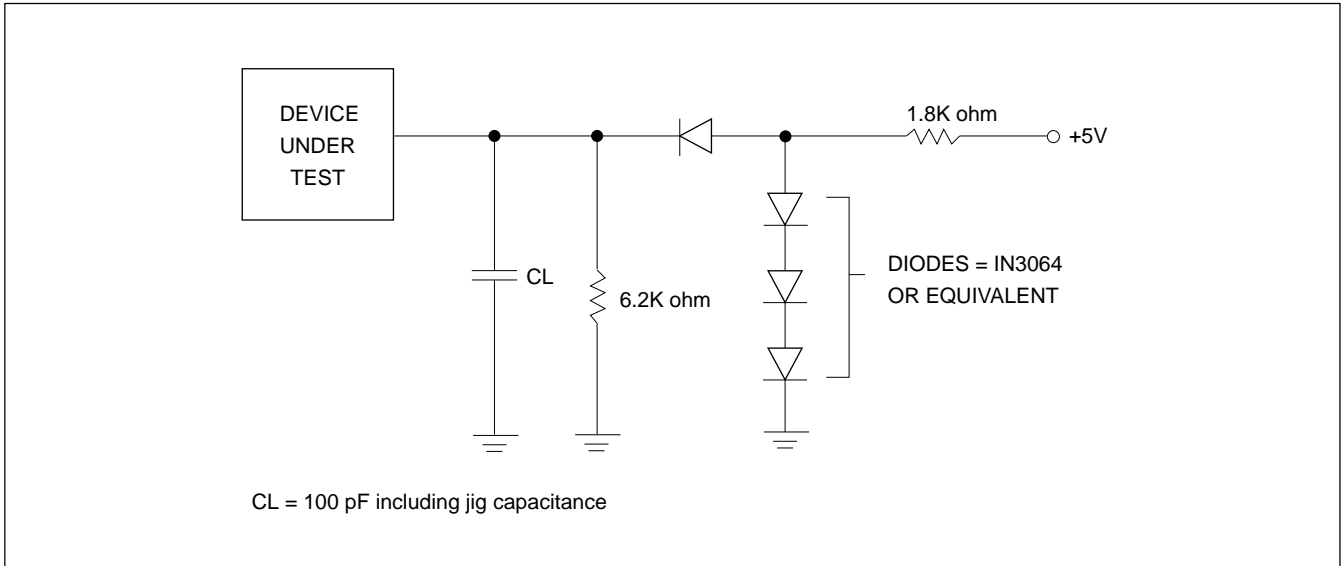

SWITCHING TEST WAVEFORMS

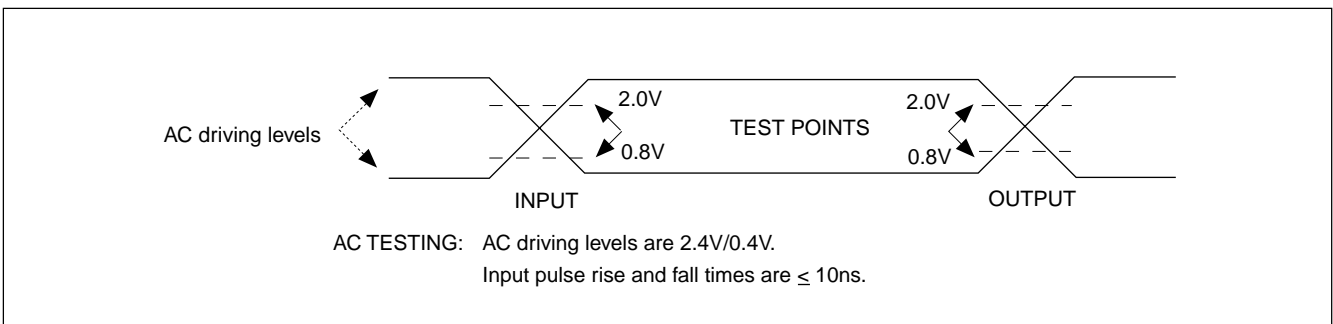



ABSOLUTE MAXIMUM RATINGS

RATING	VALUE
Ambient Operating Temperature	0°C to 70°C
Storage Temperature	-65°C to 125°C
Applied Input Voltage	-0.5V to 7.0V
Applied Output Voltage	-0.5V to VCC + 0.5V
VCC to Ground Potential	-0.5V to 7.0V
A9 & VPP	-0.5V to 13.5V

NOTICE:

Stresses greater than those listed under ABSOLUTE MAXIMUM RATINGS may cause permanent damage to the device. This is a stress rating only and functional operation of the device at these or any other conditions above those indicated in the operational sections of this specification is not implied. Exposure to absolute maximum rating conditions for extended period may affect reliability.

NOTICE:

Specifications contained within the following tables are subject to change.

DC/AC Operating Conditions for Read Operation

		MX27C8100			
		-10	-12	-15	-20
Operating Temperature	Commercial	0°C to 70°C	0°C to 70°C	0°C to 70°C	0°C to 70°C
Vcc Power Supply		5V ± 10%	5V ± 10%	5V ± 10%	5V ± 10%

DC CHARACTERISTICS

SYMBOL	PARAMETER	MIN.	MAX.	UNIT	CONDITIONS
VOH	Output High Voltage	2.4		V	IOH = -0.4mA
VOL	Output Low Voltage		0.4	V	IOL = 2.1mA
VIH	Input High Voltage	2.0	VCC + 0.5	V	
VIL	Input Low Voltage	-0.3	0.8	V	
ILI	Input Leakage Current	-10	10	uA	VIN = 0 to 5.5V
ILO	Output Leakage Current	-10	10	uA	VOUT = 0 to 5.5V
ICC3	VCC Power-Down Current		100	uA	$\overline{CE} = VCC \pm 0.3V$
ICC2	VCC Standby Current		1.5	mA	$\overline{CE} = VIH$
ICC1	VCC Active Current		60	mA	$\overline{CE} = VIL, f=5MHz, I_{out} = 0mA$
IPP	VPP Supply Current Read		10	uA	$\overline{CE} = \overline{OE} = VIL, VPP = 5.5V$

CAPACITANCE TA = 25°C, f = 1.0 MHz (Sampled only)

SYMBOL	PARAMETER	TYP.	MAX.	UNIT	CONDITIONS
CIN	Input Capacitance	8	12	pF	VIN = 0V
COUT	Output Capacitance	8	12	pF	VOUT = 0V
CVPP	VPP Capacitance	18	25	pF	VPP = 0V



MX27C8100

AC CHARACTERISTICS

SYMBOL	PARAMETER	27C8100-10		27C8100-12		27C8100-15		27C8100-20		UNIT	CONDITIONS
		MIN.	MAX.	MIN.	MAX.	MIN.	MAX.	MIN.	MAX.		
tACC	Address to Output Delay		100		120		150		200	ns	$\overline{CE} = \overline{OE} = \text{VIL}$
tCE	Chip Enable to Output Delay		100		120		150		200	ns	$\overline{OE} = \text{VIL}$
tOE	Output Enable to Output Delay		40		50		65		80	ns	$\overline{CE} = \text{VIL}$
tDF	\overline{OE} High to Output Float, or \overline{CE} High to Output Float	0	30	0	35	0	50	0	50	ns	
tOH	Output Hold from Address, \overline{CE} or \overline{OE} which ever occurred first	0		0		0		0		ns	
tBHA	\overline{BYTE} Access Time		100		120		150		200	ns	
tOHB	\overline{BYTE} Output Hold Time	0		0		0		0		ns	
tBHZ	\overline{BYTE} Output Delay Time		70		70		70		70	ns	
tBLZ	\overline{BYTE} Output Set Time	10		10		10		10		ns	

DC PROGRAMMING CHARACTERISTICS TA = 25°C ± 5°C

SYMBOL	PARAMETER	MIN.	MAX.	UNIT	CONDITIONS
VOH	Output High Voltage	2.4		V	IOH = -0.40mA
VOL	Output Low Voltage		0.4	V	IOL = 2.1mA
VIH	Input High Voltage	2.0	VCC + 0.5	V	
VIL	Input Low Voltage	-0.3	0.8	V	
ILI	Input Leakage Current	-10	10	uA	VIN = 0 to 5.5V
VH	A9 Auto Select Voltage	11.5	12.5	V	
ICC3	VCC Supply Current (Program & Verify)		50	mA	
IPP2	VPP Supply Current(Program)		30	mA	$\overline{CE} = \text{VIL}, \overline{OE} = \text{VIH}$
VCC1	Fast Programming Supply Voltage	6.00	6.50	V	
VPP1	Fast Programming Voltage	12.5	13.0	V	

AC PROGRAMMING CHARACTERISTICS TA = 25°C ± 5°C

SYMBOL	PARAMETER	MIN.	TYP.	MAX.	UNIT
tAS	Address Setup Time	2.0			us
tOES	OE Setup Time	2.0			us
tDS	Data Setup Time	2.0			us
tAH	Address Hold Time	0			us
tDH	Data Hold Time	2.0			us
tDFP	Chip Enable to Output Float Delay	0		130	ns
tVCS	VCC Setup Time	2.0			us
tVPS	\overline{BYTE} /VPP Setup Time	2.0			us
tPW	\overline{CE} initial Program Pulse Width		50		us
tOE	Data valid from \overline{OE}			150	ns

WAVEFORMS READ CYCLE(WORD MODE)

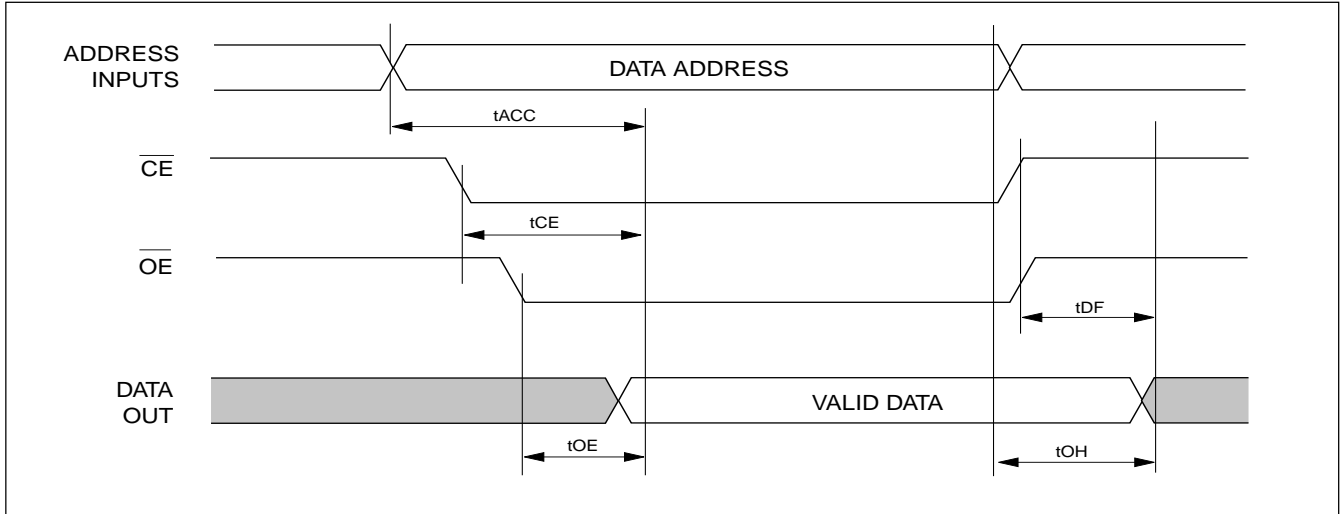

READ CYCLE(BYTE MODE)

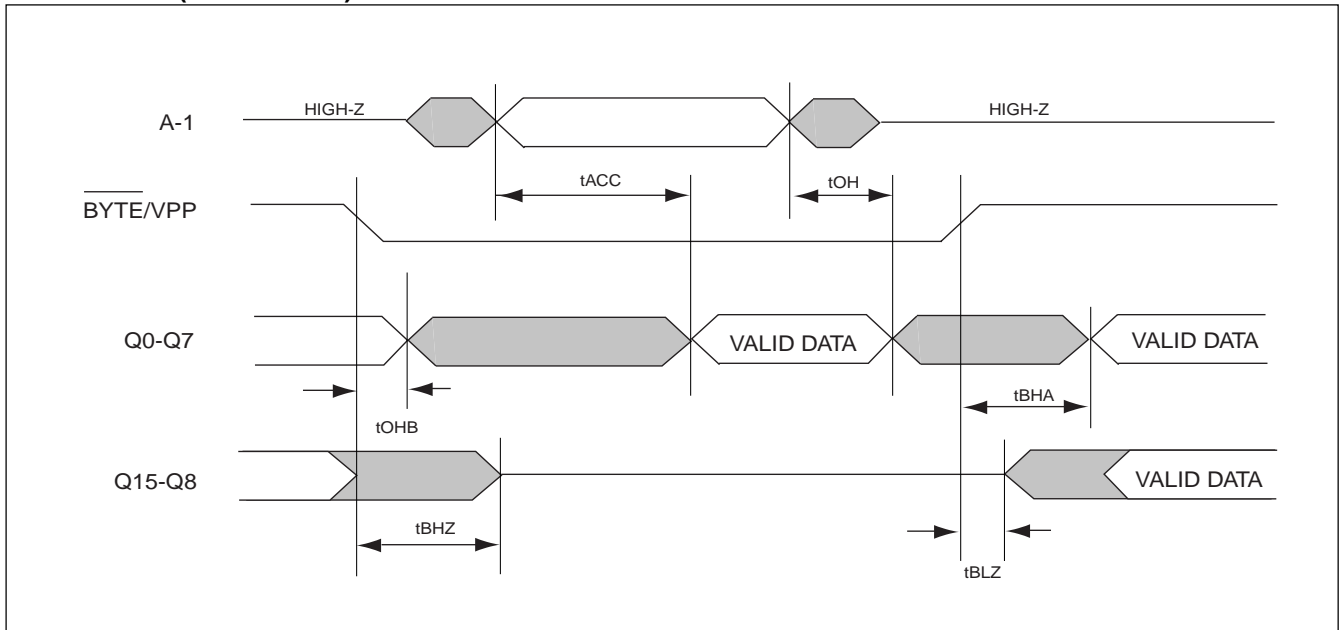

WAVEFORMS

FAST PROGRAMMING ALGORITHM WAVEFORMS

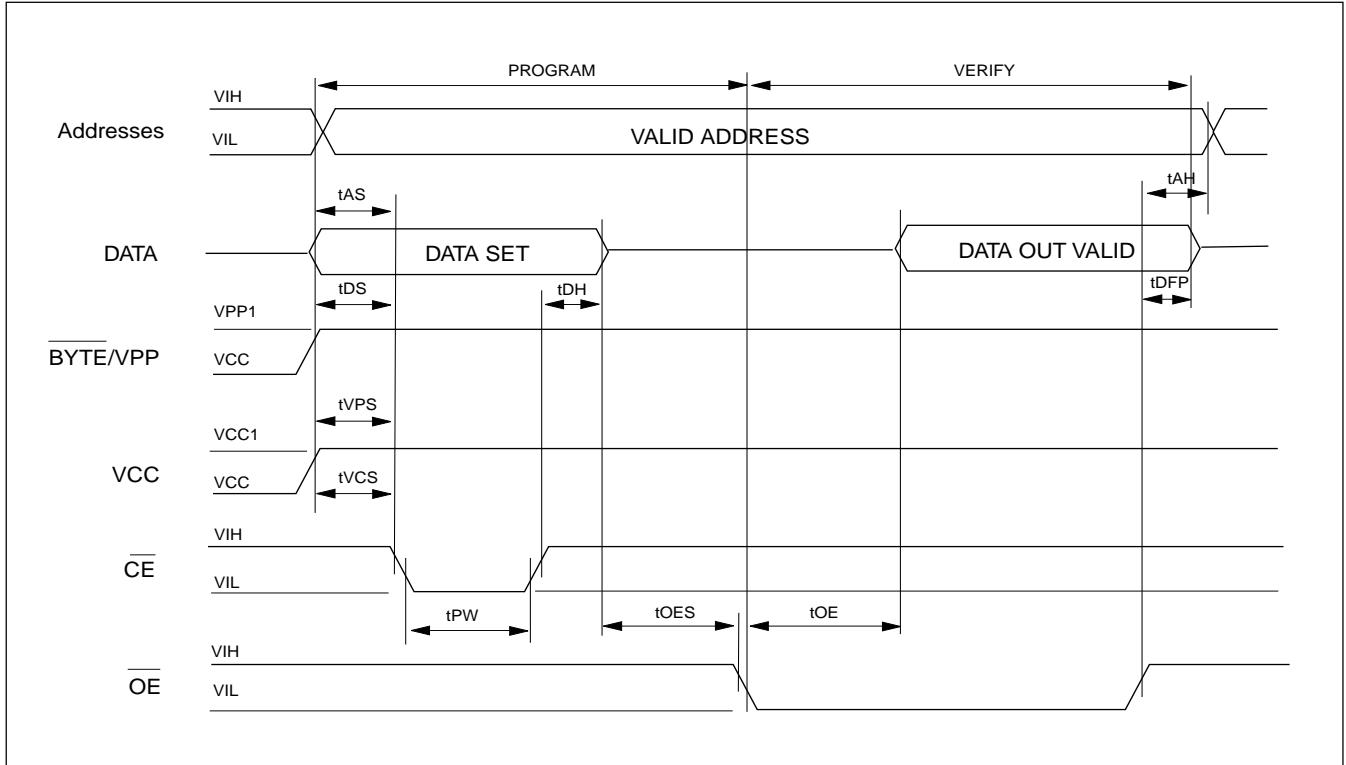



MX27C8100

ORDERING INFORMATION

PLASTIC PACKAGE

PART NO.	ACCESS TIME (ns)	OPERATING CURRENT MAX.(mA)	STANDBY CURRENT MAX.(uA)	PACKAGE
MX27C8100PC-10	100	60	100	42 Pin DIP(ROM pin out)
MX27C8100PC-12	120	60	100	42 Pin DIP(ROM pin out)
MX27C8100PC-15	150	60	100	42 Pin DIP(ROM pin out)
MX27C8100PC-20	200	60	100	42 Pin DIP(ROM pin out)
MX27C8100MC-10	100	60	100	44 Pin SOP(ROM pin out)
MX27C8100MC-12	120	60	100	44 Pin SOP(ROM pin out)
MX27C8100MC-15	150	60	100	44 Pin SOP(ROM pin out)
MX27C8100MC-20	200	60	100	44 Pin SOP(ROM pin out)



MX27C8100

PACKAGE INFORMATION 42-PIN PLASTIC DIP(600 mil)

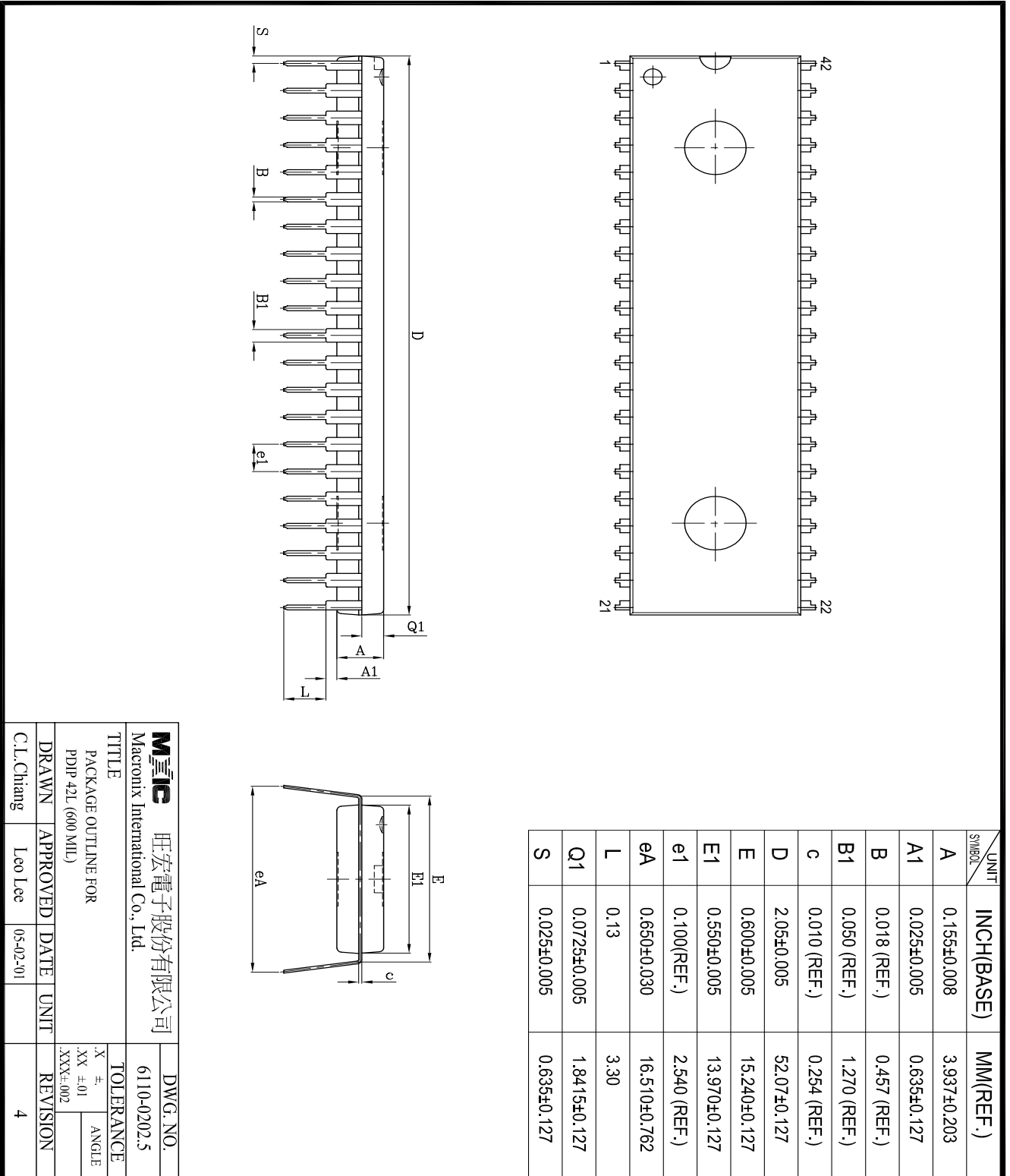

旺宏電子股份有限公司 Macronix International Co., Ltd.		DWG. NO. 6110-0202.5	
TITLE PACKAGE OUTLINE FOR PDIP-42L (600 MIL)			
TOLERANCE X # XX ±01 XXX±.002	ANGLE REVISION 4		
DRAWN C.L.Chang	APPROVED Leo Lee	DATE 05-02-01	UNIT

44-PIN PLASTIC SOP

Symbol	Dimension in mm (Base)			Dimension in Inch (Ref.)		
	Min	Nom	Max	Min	Nom	Max
A	—	—	3.00	—	—	0.118
A1	0.10	—	—	0.004	—	—
A2	2.57	2.69	2.82	0.101	0.106	0.111
b	0.41 REF			0.016 REF		
c	0.20 REF			0.008 REF		
D	28.37	28.50	28.63	1.117	1.122	1.127
E	15.77	16.03	16.28	0.621	0.631	0.641
E1	12.47	12.60	12.73	0.491	0.496	0.501
e	1.27 REF			0.050 REF		
L	0.58	0.79	0.99	0.023	0.031	0.039
θ	5°			5°		

REFERENCE DOCUMENT: JEDEC SPEC MO-175

Mxic 旺宏電子股份有限公司 Macronix International Co., Ltd.		DWG. NO. 6110-0207	
TITLE PACKAGE OUTLINE FOR SOP 44L (500 MIL)		TOLERANCE X ± XX ±01 .XXX±.002	
DRAWN C.L.Chiang	APPROVED Rick Chiu	DATE 11-1-08-01	UNIT INCH
		REVISION 3	



Revision History

Revision No.	Description	Page	Date
2.0	1) Eliminate Interactive Programming Mode. 2) Programming pulse change from 100us to 50us		5/30/1997
2.1	IPP : 100uA----> 10uA		8/8/1997
2.2	Modify Package Information	P12,13	JAN/12/2000
2.3	Modify Package Information: change title	P12	NOV/12/2001
	Modify Package Information: add coplanarity parameter	P13	



MX27C8100

MACRONIX INTERNATIONAL Co., LTD.

HEADQUARTERS:

TEL:+886-3-578-6688

FAX:+886-3-563-2888

EUROPE OFFICE:

TEL:+32-2-456-8020

FAX:+32-2-456-8021

JAPAN OFFICE:

TEL:+81-44-246-9100

FAX:+81-44-246-9105

SINGAPORE OFFICE:

TEL:+65-348-8385

FAX:+65-348-8096

TAIPEI OFFICE:

TEL:+886-2-2509-3300

FAX:+886-2-2509-2200

MACRONIX AMERICA, INC.

TEL:+1-408-453-8088

FAX:+1-408-453-8488

CHICAGO OFFICE:

TEL:+1-847-963-1900

FAX:+1-847-963-1909

[http : //www.macronix.com](http://www.macronix.com)
