



TK73200

## ADJUSTABLE LOW DROPOUT REGULATOR

### FEATURES

- Up to 5 A Output Current Capability with External PNP Transistor
- Internal Short Circuit Protection
- Excellent Load Regulation
- CMOS/TTL-Compatible On/Off Switch
- Internal Reverse Bias Current Protection Switch
- Internal Thermal Shutdown
- Wide Adjustable Output Voltage Range (2.0 V to 12.0 V)
- Continuous and Pulsed Current Modes

### DESCRIPTION

The TK73200 is a controller IC for an adjustable low dropout voltage regulator. The TK73200 and the external PNP power transistor provide adjustable output voltages from 2 to 12 V and output current from 100 mA to 5 A. By utilizing an external PNP power transistor, low dropout voltage at high current can be readily achieved. The internal electronic switch can be controlled by TTL or CMOS logic levels. The device is in the “on” state when the control pin is pulled to a high logic level. A pin for a bypass capacitor, which connects to the internal circuitry, is provided to lower the overall output noise level.

The current limit characteristics can be configured as continuous (constant current) or pulsed (cycling). An internal thermal shutdown circuit limits the junction temperatures to below 150 °C.

### APPLICATIONS

- Battery Powered Systems
- Cellular/Cordless Telephones
- Radio Control Systems
- Wireless Communications Systems
- Portable Instrumentations
- Portable Computers
- Personal Digital Assistants
- Local Area Network (LAN) Receivers
- Power Recovery for Microprocessors

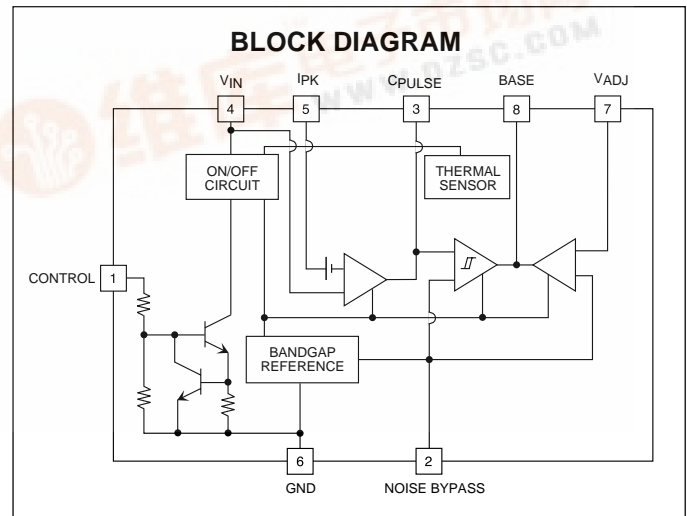
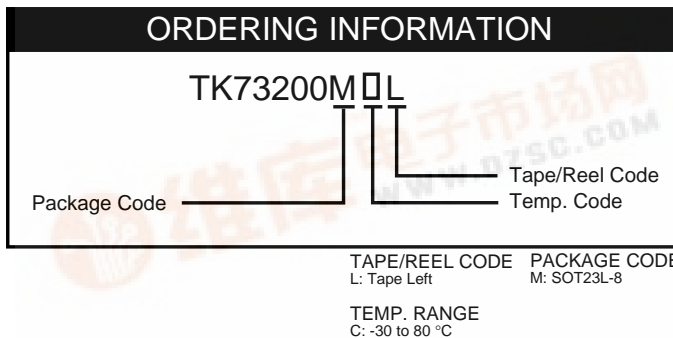
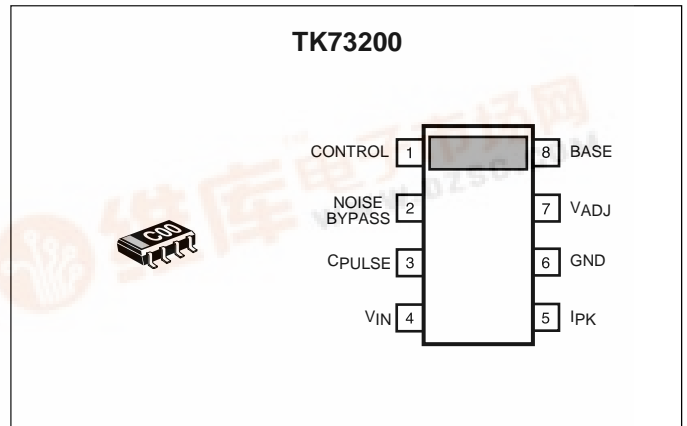

# TK73200

## ABSOLUTE MAXIMUM RATINGS (NOTE 5)

Supply Voltage Range .....	19 V	Operating Temperature Range .....	-30 to +80 °C
Power Dissipation (Note 1) .....	600 mW	Extended Temperature Range .....	-40 to +85 °C
Reverse Bias Voltage Range .....	6 V	Operating Voltage Range .....	1.8 to 14.0 V
Noise Bypass Pin Terminal Voltage Range .....	5 V	Junction Temperature .....	150 °C
Control Pin Terminal Voltage Range .....	14 V	Lead Soldering Temperature (10 s) .....	235 °C
Storage Temperature Range .....	-55 to +150 °C		

## TK73200 ELECTRICAL CHARACTERISTICS

Test conditions:  $V_{IN} = V_{OUT(TYP)} + 1 V$ ,  $T_A = 25 °C$ , unless otherwise specified.

SYMBOL	PARAMETER	TEST CONDITIONS	MIN	TYP	MAX	UNITS
$I_Q$	Quiescent Current	$I_{OUT} = 0 mA$ , Excluding $I_{CONT}$		250	360	$\mu A$
$I_{STBY}$	Standby Current	$V_{IN} = 8 V$ , Output OFF			0.1	$\mu A$
$I_{OUT}$	Output Current	External Transistor Dependent		N/A		A
$V_{DROP}$	Dropout Voltage	External Transistor Dependent		N/A		V
$V_{OUT}$	Output Voltage	Set by External Resistors	2		12	V
Line Reg	Line Regulation	$V_{IN} = V_{OUT(TYP)} + 1 V$ to $V_{OUT(TYP)} + 6 V$ (Note 2)		3.0	20	mV
Load Reg	Load Regulation	External Transistor Dependent		10		mV
$I_{BASE(L)}$	Base Current LOW	$1.8 V \leq V_{IN} \leq 4 V$	15			mA
$I_{BASE(H)}$	Base Current HIGH	$4.1 V \leq V_{IN} \leq 12 V$	40			mA
$V_{SENSE}$	Current Limit Detect Voltage	Continuous Current Limit Mode	80	100	120	mV
		Pulse Current Limit Mode	70	90	110	mV
RR	Ripple Rejection	$f = 400 Hz$ , $C_L = 10 \mu F$ , $C_N = 0.1 \mu F$ , $V_{IN} = V_{OUT(TYP)} = 1.5 V$ , $I_{OUT} = 30 mA$ , $V_{RIPPLE} = 100 mV_{rms}$ , (Note 3)		57		dB
$V_{NO}$	Output Noise	$f = 1 kHz$ , BPF = 400 Hz to 30 kHz, (Note 3)		0.13		$\mu V/\sqrt{Hz}$
$I_{PULSE}$	$C_{PULSE}$ Pin Terminal Current	(Note 4)	15	25	45	$\mu A$
$\Delta V_{OUT}/\Delta T$	Temperature Coefficient			20		ppm/°C
$V_{ref}$	Reference Voltage		1.22	1.25	1.28	V
<b>CONTROL TERMINAL SPECIFICATIONS</b>						
$I_{CONT}$	Control Current	$V_{CONT} = 1.8 V$ , Output ON		6.5	20	$\mu A$
$V_{CONT(ON)}$	Control Voltage (ON)	Output ON	1.8			V
$V_{CONT(OFF)}$	Control Voltage (OFF)	Output OFF			0.6	V

---

**TK73200 ELECTRICAL CHARACTERISTICS (STANDARD DEVICES) CONT.**

Note 1: Power dissipation is 600 mW when mounted as recommended. Derate at 4.8 mW/°C for operation above 25 °C.

Note 2: Refer to: "Definition of Terms."

Note 3: Ripple rejection and noise voltage are affected by the value and characteristics of the capacitor used.

Note 4: This pin is used for Pulse Current Limit Mode. When selecting Continuous Current Limit Mode, this pin is connected to GND.

Note 5: The voltage applied to any pin must be greater than -0.4 V.

Gen. Note: Parameters with min. or max. values are 100% tested at  $T_A = 25\text{ °C}$ .

# TK73200

## TEST CIRCUIT

Note: Transistor: 2SB1115

$C_N = 0.1 \mu\text{F}$

$C_P = 0.1 \mu\text{F}$

$C_{IN} = 1 \mu\text{F}$

$C_L = 4.7 \mu\text{F}$

$R_P = 330 \text{ k}$

Continuous Current Limit Mode:

$I_{SET} \text{ (mA)} = 100 \text{ mV} / R_{IPK} \text{ (}\Omega\text{)}$

Pulse Current Limit Mode:

$I_{SET} \text{ (mA)} = 90 \text{ mV} / R_{IPK} \text{ (}\Omega\text{)}$

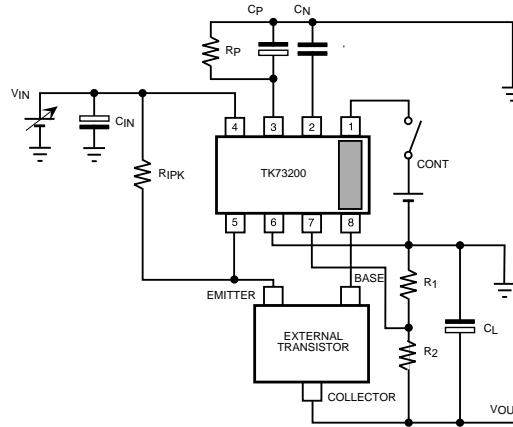

$$V_{OUT} = 1.25 (1 + R_2 / R_1)$$

$$20 \text{ k}\Omega \leq R_1 \leq 68 \text{ k}\Omega$$

$$2.0 \text{ V} \leq V_{OUT} \leq 12 \text{ V}$$

## TYPICAL PERFORMANCE CHARACTERISTICS

$T_A = 25 \text{ }^\circ\text{C}$ , external transistor is 2SB1115(NEC), unless otherwise specified.

LINE REGULATION 1

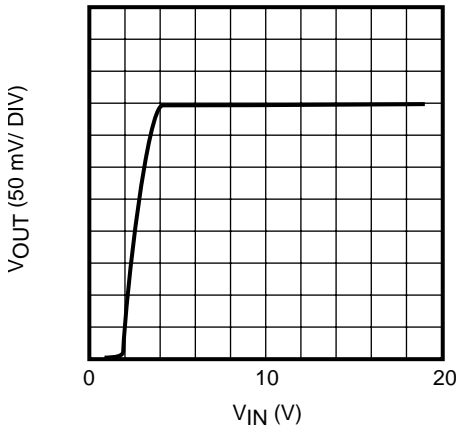

LINE REGULATION 2

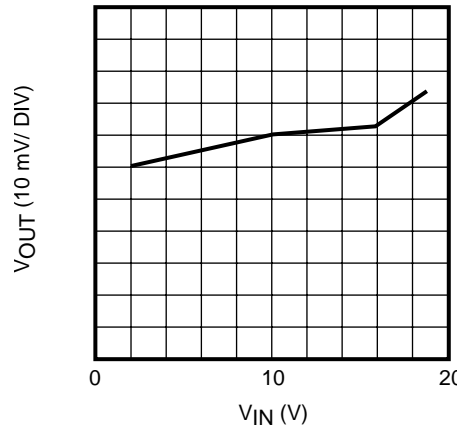

LOAD REGULATION

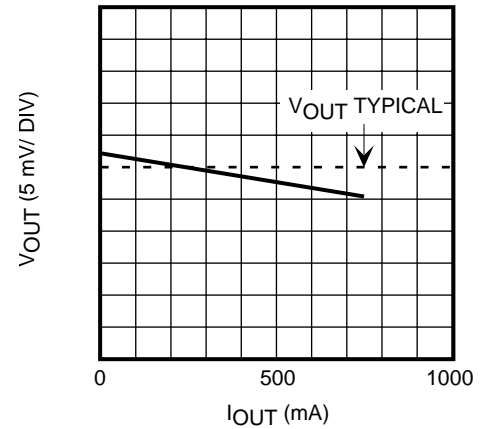

QUIESCENT CURRENT vs. INPUT VOLTAGE

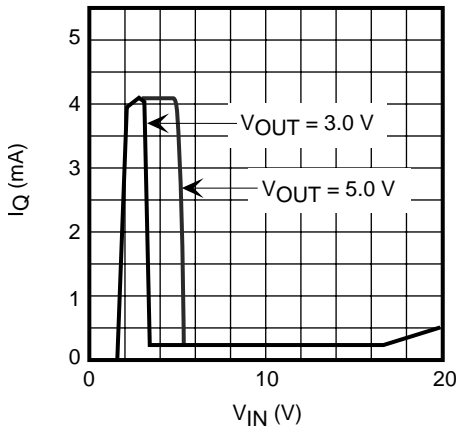

DROPOUT VOLTAGE vs. OUTPUT CURRENT AND EXTERNAL TRANSISTORS

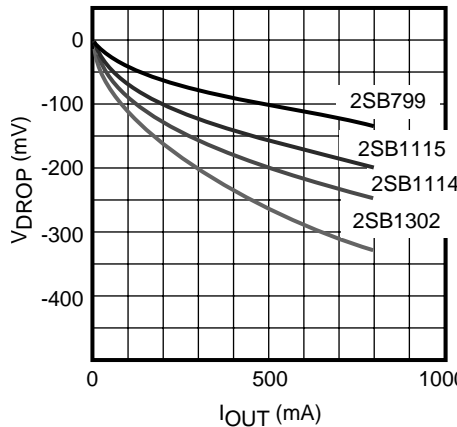

GROUND CURRENT vs. OUTPUT CURRENT

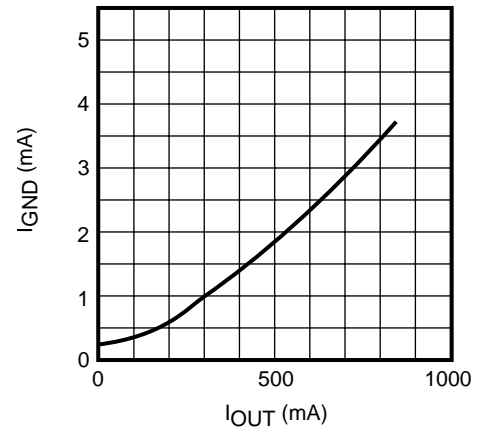

**TYPICAL PERFORMANCE CHARACTERISTICS (CONT.)**

$T_A = 25\text{ }^\circ\text{C}$ , external transistor is 2SB1115(NEC), unless otherwise specified.

**CURRENT LIMIT DETECTOR VOLTAGE vs. INPUT VOLTAGE**

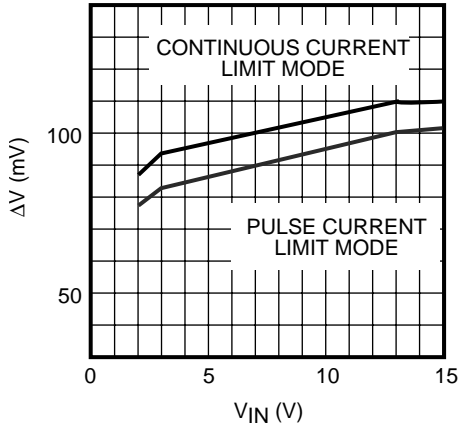

**BASE CURRENT DRIVE vs. INPUT VOLTAGE**

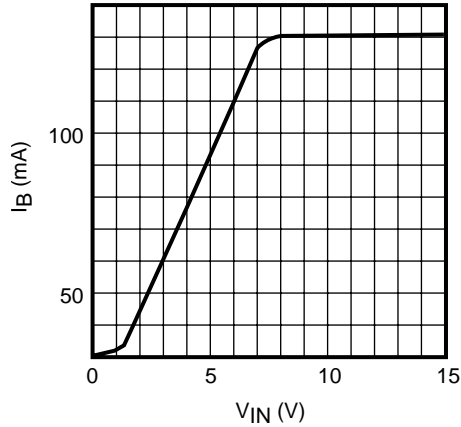

**REVERSE BIAS CURRENT (VIN = 0 TO 6 V)**

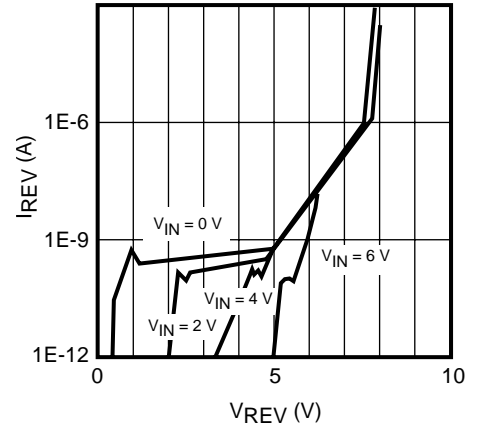

**QUIESCENT CURRENT vs. INPUT VOLTAGE (OFF MODE)**

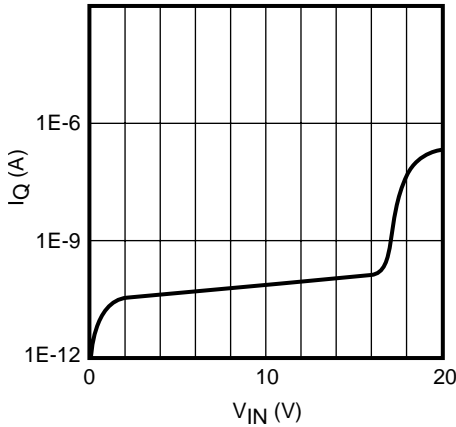

**RIPPLE REJECTION**

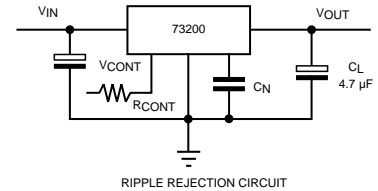
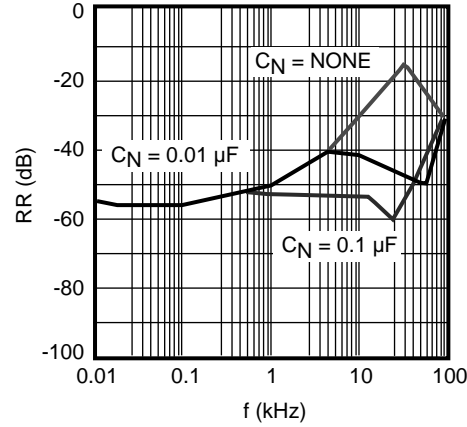

**CONTROL CURRENT vs. TEMPERATURE**

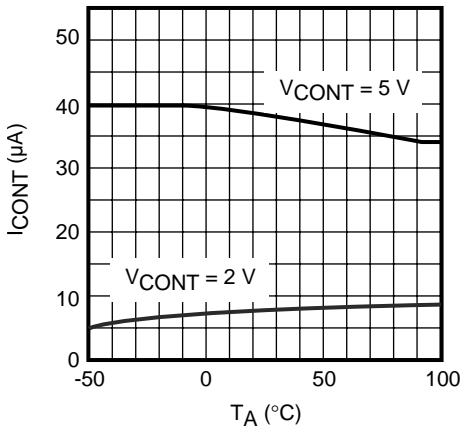

**CONTROL VOLTAGE (OUTPUT ON POINT) vs. TEMPERATURE**

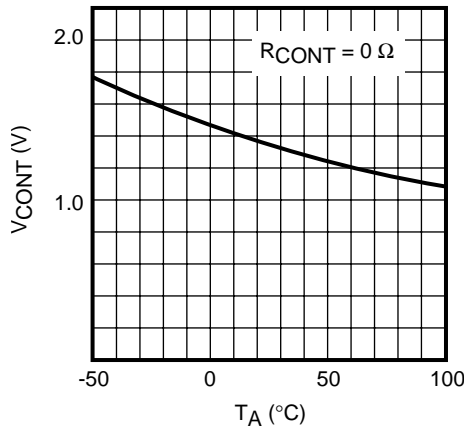

**OUTPUT VOLTAGE VARIATION vs. TEMPERATURE**

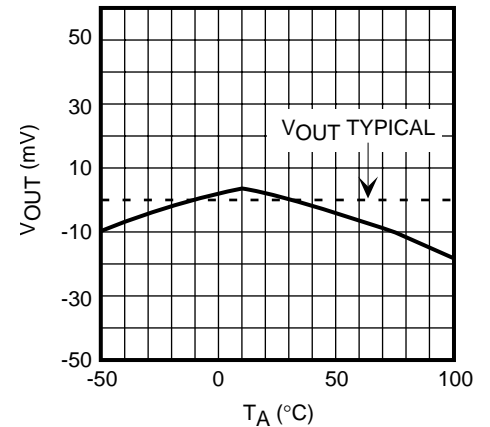

**TYPICAL PERFORMANCE CHARACTERISTICS (CONT.)**

$T_A = 25\text{ }^\circ\text{C}$ , external transistor is 2SB1115(NEC), unless otherwise specified.

**CONTROL PIN VOLTAGE vs. CONTROL CURRENT**

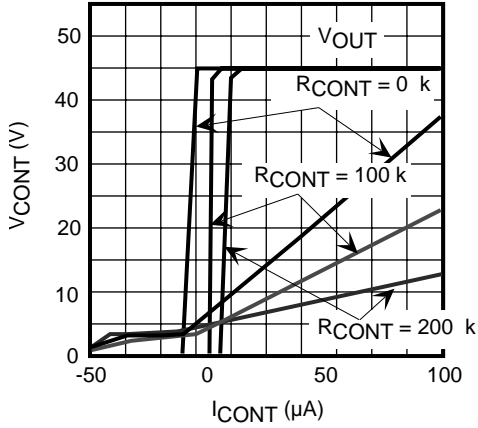

**ON/OFF TRANSIENT**

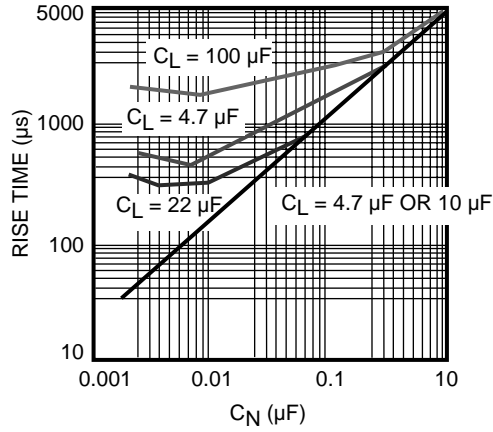

**ON/OFF STEP RESPONSE**

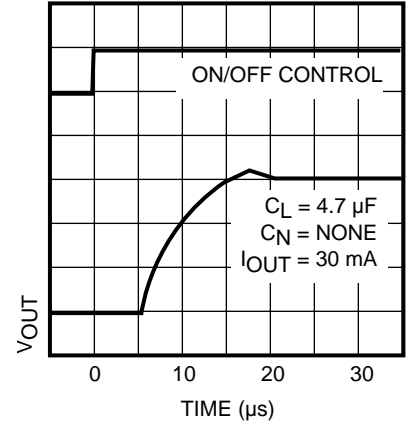

**LOAD CURRENT STEP RESPONSE**

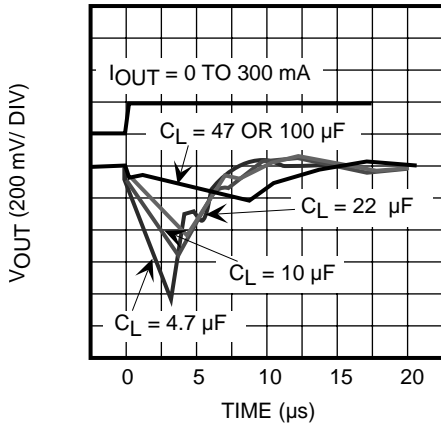

**LINE VOLTAGE STEP RESPONSE**

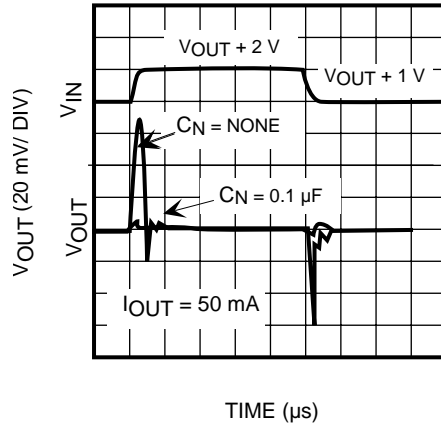

---

## DEFINITION AND EXPLANATION OF TECHNICAL TERMS

### OUTPUT VOLTAGE ( $V_{OUT}$ )

The output voltage is specified with  $V_{IN} = (V_{OUT(TYP)} + 1 \text{ V})$  and  $I_{OUT} = 30 \text{ mA}$ .

### DROPOUT VOLTAGE ( $V_{DROP}$ )

The dropout voltage is the difference between the input voltage and the output voltage at which point the regulator starts to fall out of regulation. Below this value, the output voltage will fall as the input voltage is reduced. It is dependent upon the load current, the external transistor and the junction temperature.

### BASE CONTROL CURRENT ( $I_{BASE}$ )

The base control current is the drive current for the base of the external transistor.

### OUTPUT CURRENT ( $I_{OUT}$ )

The output current depends on the characteristics of the external transistor and current limit setting.

### LINE REGULATION (Line Reg)

Line regulation is the ability of the regulator to maintain a constant output voltage as the input voltage changes. The line regulation is specified as the input voltage is changed from  $V_{IN} = V_{OUT(TYP)} + 1 \text{ V}$  to  $V_{IN} = V_{OUT(TYP)} + 6 \text{ V}$ .

### LOAD REGULATION (Load Reg)

Load regulation is the ability of the regulator to maintain a constant output voltage as the load current changes. It is a pulsed measurement to minimize temperature effects. Load regulation depends on the external transistor.

### QUIESCENT CURRENT ( $I_Q$ )

The quiescent current is the current which flows through the ground terminal under no load conditions ( $I_{OUT} = 0 \text{ mA}$ ) and excludes the control pin current.

### GROUND CURRENT ( $I_{GND}$ )

Ground current is the current which flows through the ground pin(s). It is defined as  $I_{IN} - I_{OUT}$ , excluding control current.

### RIPPLE REJECTION RATIO (RR)

Ripple rejection is the ability of the regulator to attenuate the ripple content of the input voltage at the output. It is specified with 100 mVrms, 400 Hz superimposed on the input voltage, where  $V_{IN} = V_{OUT(TYP)} + 1.5 \text{ V}$ . The output decoupling capacitor is set to 10  $\mu\text{F}$ , the noise bypass capacitor is set to 0.1  $\mu\text{F}$ , and the load current is set to 30 mA. Ripple rejection is the ratio of the ripple content of the output vs. the input and is expressed in dB.

### STANDBY CURRENT ( $I_{STBY}$ )

Standby current is the current which flows into the regulator when the output is turned off by the control function ( $V_{CONT} = 0 \text{ V}$ ). It is measured with  $V_{IN} = 8 \text{ V}$ .

### SENSOR CIRCUITS

#### Overcurrent Sensor

The overcurrent sensor protects the device if the output is shorted to ground.

#### Thermal Sensor

The thermal sensor protects the device if the junction temperature exceeds the safe value ( $T_j = 150 \text{ }^\circ\text{C}$ ). This temperature rise can be caused by extreme heat, excessive power dissipation caused by large output voltage drops, or excessive output current. The regulator will shut off when the temperature exceeds the safe value. As the junction temperature decreases, the regulator will begin to operate again. Under sustained fault conditions, the regulator output will oscillate as the device turns off then resets. Damage may occur to the device under extreme fault conditions.

#### Reverse Voltage Protection

Reverse voltage protection prevents damage due to the output voltage being higher than the input voltage. This fault condition can occur when the output capacitor remains charged and the input is reduced to zero, or when an external voltage higher than the input voltage is applied to the output side.

**DEFINITION AND EXPLANATION OF TECHNICAL TERMS (CONT.)**

**PACKAGE POWER DISSIPATION (P<sub>D</sub>)**

This is the power dissipation level at which the thermal sensor is activated. The IC contains an internal thermal sensor which monitors the junction temperature. When the junction temperature exceeds the monitor threshold of 150 °C, the IC is shut down. The junction temperature rises as the difference between the input power (V<sub>IN</sub> x I<sub>IN</sub>) and the output power (V<sub>OUT</sub> x I<sub>OUT</sub>) increases. The rate of temperature rise is greatly affected by the mounting pad configuration on the PCB, the board material, and the ambient temperature. When the IC mounting has good thermal conductivity, the junction temperature will be low even if the power dissipation is great. When mounted on the recommended mounting pad, the power dissipation of the SOT23L-8 is increased to 600 mW. For operation at ambient temperatures over 25 °C, the power dissipation of the SOT23L-8 device should be derated at 4.8 mW/°C. To determine the power dissipation for shutdown when mounted, attach the device on the actual PCB and deliberately increase the output current (or raise the input voltage) until the thermal protection circuit is activated. Calculate the power dissipation of the device by subtracting the output power from the input power. These measurements should allow for the ambient temperature of the PCB. The value obtained from P<sub>D</sub>/(150 °C - T<sub>A</sub>) is the derating factor. The PCB mounting pad should provide maximum thermal conductivity in order to maintain low device temperatures. As a general rule, the lower the temperature, the better the reliability of the device. The thermal resistance when mounted is expressed as follows:

$$T_j = \theta_{jA} \times P_D + T_A$$

For Toko ICs, the internal limit for junction temperature is 150 °C. If the ambient temperature (T<sub>A</sub>) is 25 °C, then:

$$150 \text{ °C} = \theta_{jA} \times P_D + 25 \text{ °C}$$

$$\theta_{jA} = 125 \text{ °C} / P_D$$

P<sub>D</sub> is the value when the thermal sensor is activated. A simple way to determine P<sub>D</sub> is to calculate V<sub>IN</sub> x I<sub>IN</sub> when the output side is shorted. Input current gradually falls as temperature rises. You should use the value when thermal equilibrium is reached.

The range of usable currents can also be found from the graph below.

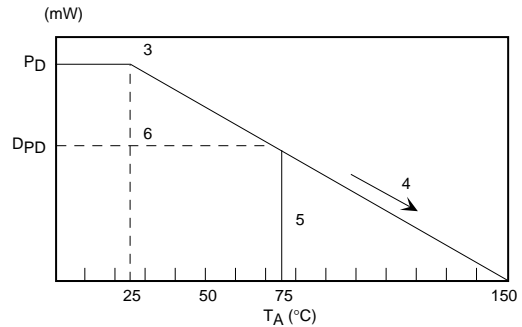

Procedure:

- 1) Find P<sub>D</sub>
- 2) P<sub>D1</sub> is taken to be P<sub>D</sub> x (Note: It is not necessary to connect a ceramic capacitor in parallel with an aluminum or tantalum output capacitor. (~0.8 - 0.9))
- 3) Plot P<sub>D1</sub> against 25 °C
- 4) Connect P<sub>D1</sub> to the point corresponding to the 150 °C with a straight line.
- 5) In design, take a vertical line from the maximum operating temperature (e.g., 75 °C) to the derating curve.
- 6) Read off the value of P<sub>D</sub> against the point at which the vertical line intersects the derating curve. This is taken as the maximum power dissipation, D<sub>PD</sub>.

The maximum operating current is:

$$I_{OUT} = (D_{PD} / (V_{IN(MAX)} - V_{OUT}))$$

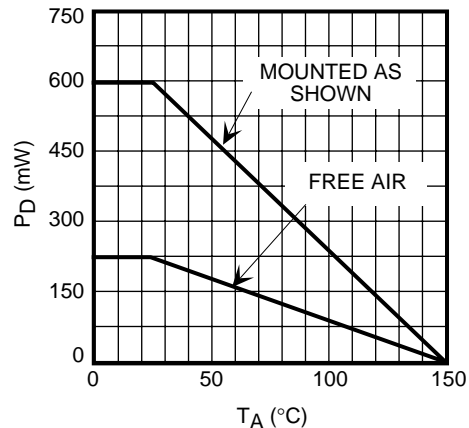

**SOT23L-8 POWER DISSIPATION CURVE**



## APPLICATION INFORMATION

### INPUT-OUTPUT CAPACITORS

The output capacitor is necessary for stable operation. The regulator may oscillate if the output capacitor is too small or missing. The output capacitor size is determined by load, transient response and external transistor used. Evaluation in the circuit is recommended to ensure performance requirements are satisfied. A minimum of 4.7  $\mu\text{F}$  is necessary for stability, with twice that value recommended. The minimum recommended input capacitor is 1  $\mu\text{F}$ . Problems do not occur with larger values of capacitance. However, extremely low ESR may result in unstable operation. Thus, the use of large value ceramic capacitors is not recommended on the output.

### EVALUATION BOARD

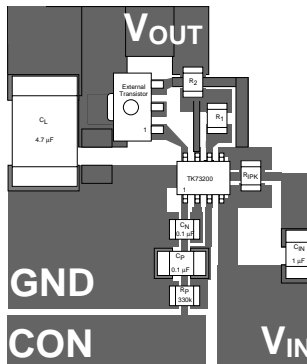

TOKO

AP008-99

### SOT23L-8 BOARD LAYOUT

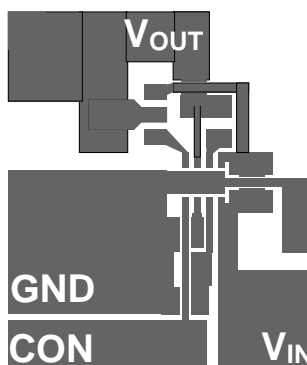

TOKO

AP008-99

### PULSE CURRENT LIMIT MODE

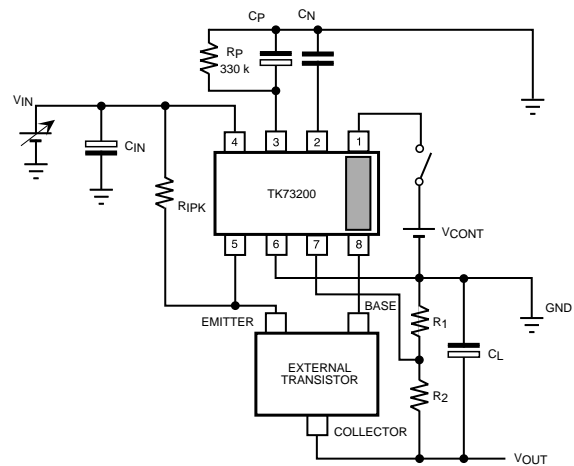

The equation for the pulse output current limit is as follows:

$$I_{SET} \text{ (mA)} = 90 \text{ (mV)} / R_{IPK} \text{ (\Omega)}$$

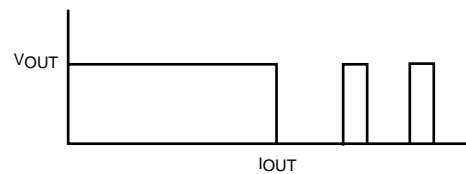

During the initial turn-on, charge (surge) current flows to the output capacitor. This IC has a possibility for the current limit to operate and to turn off the output by the charge current of the output capacitor. Therefore, the relationship between  $C_L$  and  $C_p$  is set as shown in the graph below:

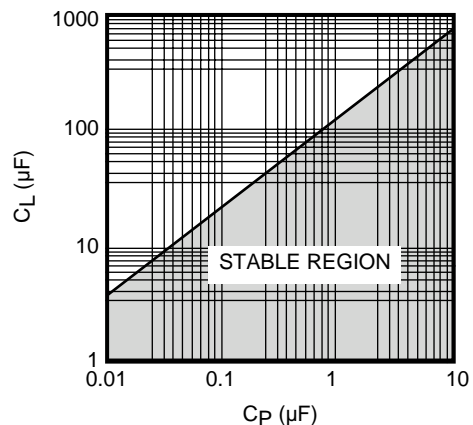

## APPLICATION INFORMATION (CONT.)

### CONTINUOUS CURRENT LIMIT MODE

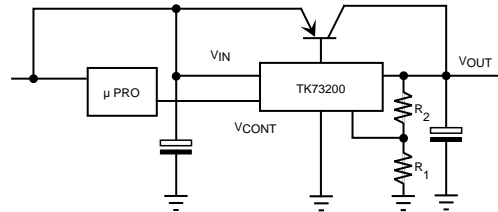
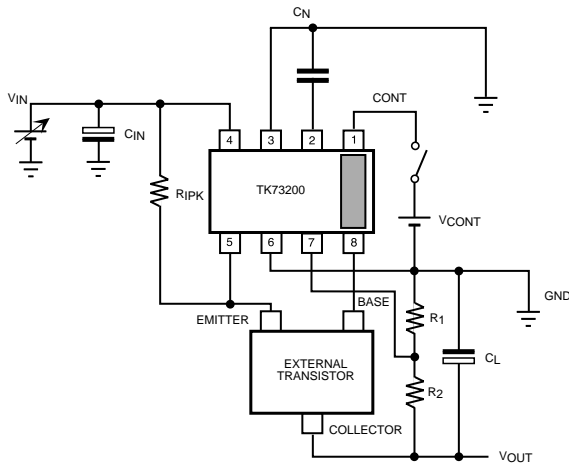

The high output voltage accuracy and low dropout voltage are maintained when the IC is turned ON/OFF by using the control pin as illustrated above.

In the continuous current limit mode, the  $C_{PULSE}$  pin (pin 3) is directly connected to ground. The output current limit is set by  $R_{IPK}$  according to the following equation:

$$I_{SET} \text{ (mA)} = 100 \text{ (mV)} / R_{IPK} \text{ (}\Omega\text{)}$$

If the continuous current limit mode is also used for output short circuit protection, the  $I_{SET}$  value is set 50% to 100% more than the maximum operating current. The current transistor is selected from the  $I_{SET}$  value. The output voltage drops when the output current exceeds the  $I_{SET}$  value. However, the output voltage returns to normal once the output current decreases below the  $I_{SET}$  value.

### HIGH-SIDE SWITCHING

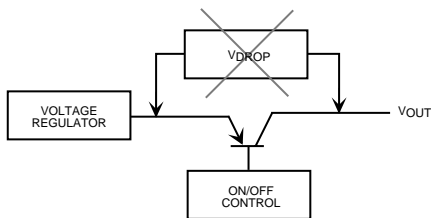

High-side switching should not be implemented by an external transistor as shown above. This results in additional voltage drop and loss of accuracy.

## APPLICATION INFORMATION (CONT.)

### EXTERNAL PNP POWER TRANSISTOR

This IC can use any kind of external transistor. The external transistor selection is a function of the load current,  $H_{fe}$  and power dissipation. See following chart:

LOAD CURRENT	RECOMMENDED EXTERNAL TRANSISTOR	RECOMMENDED $R_{IPK}$ ( $\Omega$ )
0 ~ 180 mA	2SB624, 2SB1115, 2SB799 (NEC), 2SB970 (Matsushita)	0.33 ~ 0.39
0 ~ 300 mA	2SB1115, 2SB799 (NEC)	0.22 ~ 0.27
0 ~ 500 mA	2SB1114, 2SB1115 (NEC), 2SB1302 (Sanyo), 2SA1203, 2SA1213, 2SA1734 (Toshiba)	0.12 ~ 0.15
0 ~ 1 A	2SA1242, 2SA1736 (Toshiba), 2SB1302, 2SA1896 (Sanyo)	0.056 ~ 0.068
0 ~ 2 A	2SA1451, 2SA1242 (Toshiba)	0.033 ~ 0.039
0 ~ 3 A	2SA1451 (Toshiba), 2SA1645 (NEC)	0.022 ~ 0.027
0 ~ 4 A	2SA1451 (Toshiba), 2SB904 (Sanyo), 2SA1645 (NEC)	0.012 ~ 0.015

### VOLTAGE BACKUP OPERATION (HOLDUP TIME)

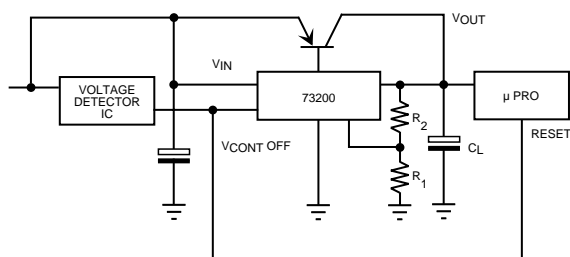

$C_L$  becomes the backup power supply when the microprocessor is reset with the voltage detector IC simultaneously with turning OFF the TK73200.  $C_L$  provides the holdup time necessary to do an orderly shutdown of the microprocessor.

### PARALLEL ON/OFF CONTROL OPERATION

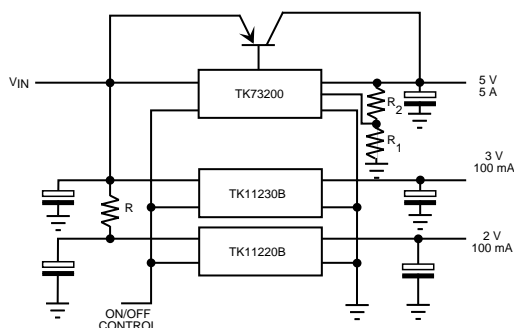

The figure above illustrates multiple regulators being controlled by a single ON/OFF control signal. The series resistor R is put in the input line of the low output voltage regulator in order to prevent overdissipation. The voltage dropped across the resistor reduces the large input-to-output voltage across the regulator, reducing the power dissipation in the device.

PACKAGE OUTLINE

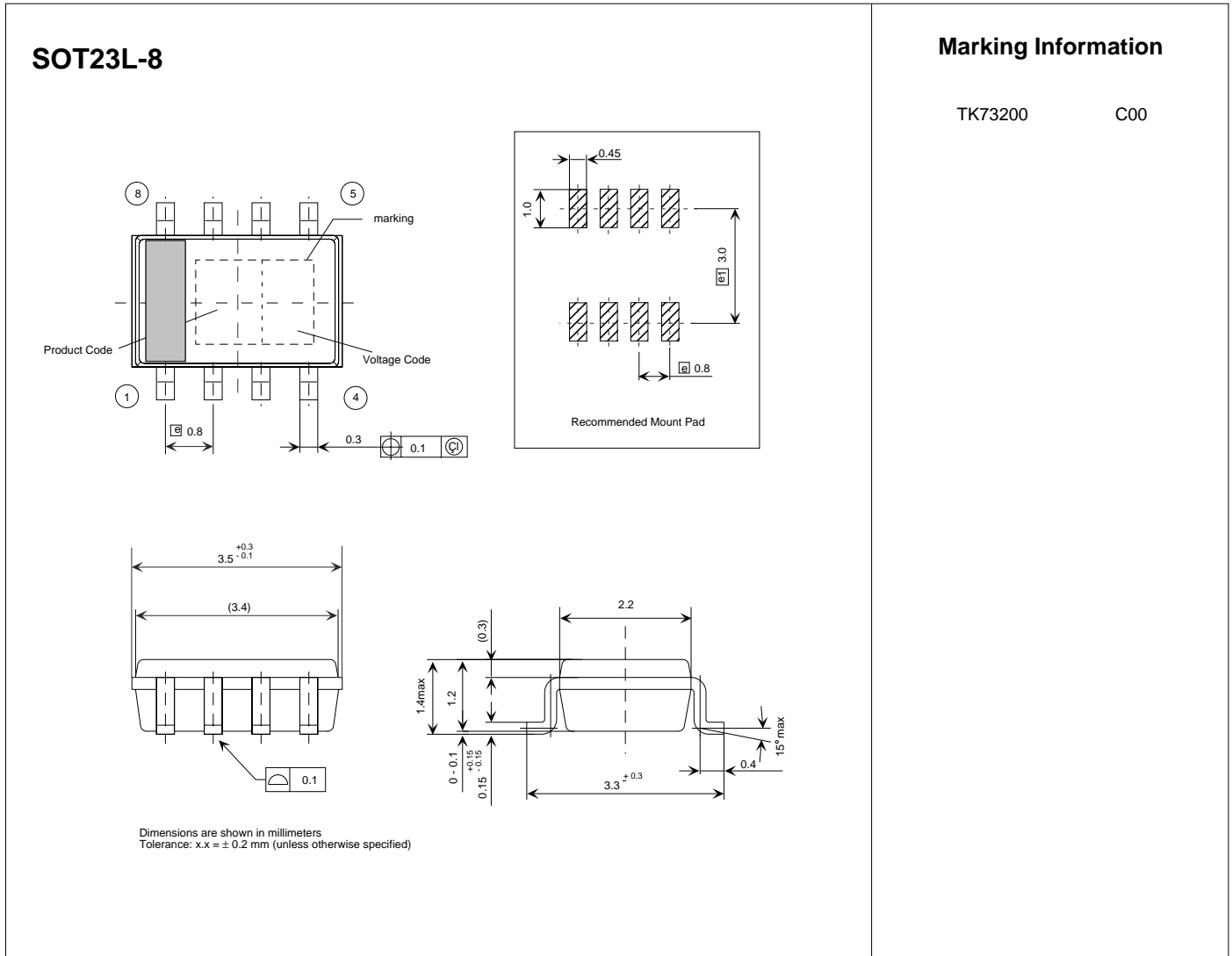

Toko America, Inc. Headquarters  
 1250 Feehanville Drive, Mount Prospect, Illinois 60056  
 Tel: (847) 297-0070 Fax: (847) 699-7864

TOKO AMERICA REGIONAL OFFICES

Midwest Regional Office  
 Toko America, Inc.  
 1250 Feehanville Drive  
 Mount Prospect, IL 60056  
 Tel: (847) 297-0070  
 Fax: (847) 699-7864

Western Regional Office  
 Toko America, Inc.  
 2480 North First Street, Suite 260  
 San Jose, CA 95131  
 Tel: (408) 432-8281  
 Fax: (408) 943-9790

Eastern Regional Office  
 Toko America, Inc.  
 107 Mill Plain Road  
 Danbury, CT 06811  
 Tel: (203) 748-6871  
 Fax: (203) 797-1223

Semiconductor Technical Support  
 Toko Design Center  
 4755 Forge Road  
 Colorado Springs, CO 80907  
 Tel: (719) 528-2200  
 Fax: (719) 528-2375

Visit our Internet site at <http://www.tokoam.com>

The information furnished by TOKO, Inc. is believed to be accurate and reliable. However, TOKO reserves the right to make changes or improvements in the design, specification or manufacture of its products without further notice. TOKO does not assume any liability arising from the application or use of any product or circuit described herein, nor for any infringements of patents or other rights of third parties which may result from the use of its products. No license is granted by implication or otherwise under any patent or patent rights of TOKO, Inc.