



Microsemi

8700 E. Thomas Rd.
Scottsdale, AZ 85252
PH: (480) 941-6300
FAX: (480) 947-1503

Features

- Zener Voltage 3.9 to 100V
- Voltage Tolerances; $\pm 5\%$, $\pm 10\%$ (See Note 1)
- Low profile cost effective TO-220 package

Maximum Ratings

Junction and Storage Temperatures: - 65°C to + 175°C
DC Power Dissipation: 10 Watts
Power Derating: 200 mW/°C above 100°C base temperature (see figure 2)
Forward Voltage @ 2.0A: 1.5 Volts

Mechanical Characteristics

Case: Industry Standard TO-220
Finish: All external surfaces are corrosion resistant and terminal solderable.
Weight: 2.3 grams
Mounting Position: Any
Thermal Resistance: 5°C/W (Typical) junction to base.
Polarity: Standard polarity is anode to base (pin 2) And pins 1 and 3 are cathode. Reverse polarity (cathode to base) is also available with R suffix.

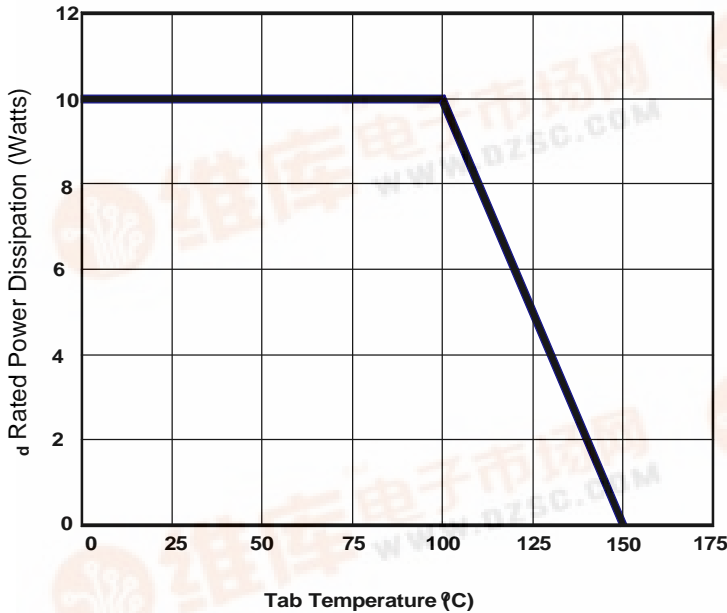
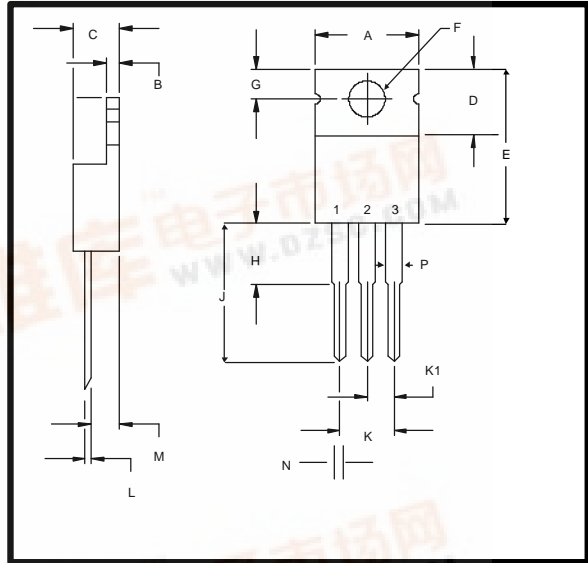

Figure 2
Power Derating Curve

**10EZ3.9
thru
10EZ100**

**Silicon
10 WATT
Zener Diodes**



DIM	INCHES		MILIMETER		NOTES
	MIN	MAX	MIN	MAX	
A	.390	.415	9.91	10.54	
B	.045	.055	1.14	1.40	
C	.180	.190	4.57	4.83	
D	.245	.260	6.22	6.60	
E	.590	.605	14.99	15.37	
F	.139	.147	3.53	3.73	DIA.
G	.100	.120	2.54	3.05	
H	—	.250		6.35	
J	.540	.570	13.72	14.48	
K	.190	.210	4.83	5.33	
K1	.090	.110	2.29	2.79	
L	.021	.025	5.33	6.40	
M	.080	.115	2.03	2.92	
N	.028	.038	.710	.970	
P	.045	.055	1.14	1.40	



Microsemi Part Number	Nominal Zener Voltage V_Z @ I_{ZT} Volts (Note 2)	Zener Test Current (I_{ZT}) mA	Max. Dynamic Impedance (Note 3)		Max DC Zener Current (I_{ZM}) @ 75°C Base Temp. (Note 4) mA	Typical Temperature Coefficient α_{VZ} %/°C	Max** Leakage Current	
			Z_{ZT} @ I_{ZT} OHMS	Z_{ZK} @ 1mA (I_{ZK}) OHMS			I_R @ V_R μ A	Volts
10EZ3.9	3.9	640	2.0	400	2380	— .046	100	0.5
10EZ4.3	4.3	580	1.5	400	2130	— .033	100	0.5
10EZ4.7	4.7	530	1.2	500	1940	— .015	80	1.0
10EZ5.1	5.1	490	1.1	550	1780		10	1.0
10EZ5.6	5.6	445	1.0	600	1620	\pm .010	10	1.0
10EZ6.2	6.2	405	1.1	750	1460	+ .049	10	2.0
10EZ6.8	6.8	370	1.2	500	1320	.040	150	5.2
10EZ7.5	7.5	335	1.3	250	1180	.045	100	5.7
10EZ8.2	8.2	305	1.5	250	1040	.048	50	5.2
10EZ9.1	9.1	275	2.0	250	960	.051	25	6.9
10EZ10	10	250	3	250	860	.055	25	7.6
10EZ11	11	230	3	250	780	.060	10	8.4
10EZ12	12	210	3	250	720	.065	10	9.1
10EZ13	13	190	3	250	660	.065	10	9.9
10EZ14	14	180	3	250	600	.070	10	10.5
10EZ15	15	170	3	250	560	.070	10	11.4
10EZ16	16	155	4	250	530	.070	10	12.2
10EZ17	17	145	4	250	500	.075	10	13.0
10EZ18	18	140	4	250	460	.075	10	13.7
10EZ19	19	130	4	250	440	.075	10	14.0
10EZ20	20	125	4	250	420	.075	10	15.2
10EZ22	22	115	5	250	380	.080	10	16.7
10EZ24	24	105	5	250	350	.080	10	18.2
10EZ25	25	100	6	250	310	.080	10	18.2
10EZ27	27	95	7	250	300	.085	10	20.6
10EZ30	30	85	8	300	280	.085	10	22.8
10EZ33	33	75	9	300	260	.085	10	25.1
10EZ36	36	70	10	300	230	.085	10	27.4
10EZ39	39	65	11	300	210	.090	10	29.7
10EZ43	43	60	12	400	195	.090	10	32.7
10EZ45	45	55	13	400	185	.090	10	33.0
10EZ47	47	55	14	400	175	.090	10	35.8
10EZ50	50	50	15	500	165	.090	10	36.0
10EZ51	51	50	15	500	160	.090	10	38.8
10EZ52	52	50	15	500	160	.090	10	39.0
10EZ56	56	45	16	500	150	.090	10	42.6
10EZ62	62	40	17	600	130	.090	10	47.1
10EZ68	68	37	18	600	120	.090	10	51.7
10EZ75	75	33	22	600	110	.090	10	56.0
10EZ82	82	30	25	700	100	.090	10	62.2
10EZ91	91	28	35	800	85	.090	10	69.2
10EZ100	100	25	40	900	80	.090	10	76.0

NOTE 1. 10EZ3.9 – 10EZ100A series: suffix A indicates \pm 5% tolerance, no suffix indicates \pm 10% tolerance. If tighter tolerance is required, consult factory.

NOTE 2. The electrical characteristics are measured after allowing the device to stabilize for 90 seconds with 30°C base temperature. Voltage change with other current values are described in Micronote 202.

NOTE 3. The zener impedance (Z_{ZT}) is derived from the 60 Hz ac voltage, which results when an ac current having an rms value equal to 10% of the dc zener current (I_{ZT} or I_{ZK}) is superimposed on I_{ZT} or I_{ZK} . Dynamic impedance variations with other current values are described in Micronote 202.

NOTE 4. These values of I_{ZM} may be exceeded in the case of individual diodes. The values shown are calculated for the worst case which is at the high voltage end of its tolerance range (for \pm 5%). Allowance has also been made for the rise in zener voltage above V_{ZT} , which results from zener impedance and the increase in junction temperature as power dissipation approaches 10 watts.