



CY7C1021B
CY7C10211B

1-Mbit (64K x 16) Static RAM

Features

- **Temperature Ranges**
 - Commercial: 0°C to 70°C
 - Industrial: -40°C to 85°C
 - Automotive: -40°C to 125°C
- **High speed**
 - $t_{AA} = 10$ ns (Commercial & Industrial)
 - $t_{AA} = 15$ ns (Automotive)
- **CMOS for optimum speed/power**
- **Low active power**
 - 825 mW (max.)
- **Automatic power-down when deselected**
- **Independent control of upper and lower bits**
- **Available in 44-pin TSOP II and 400-mil SOJ**
- **Also available in Lead (Pb)-Free 44-pin TSOP II**

Functional Description^[1]

The CY7C1021B/10211B is a high-performance CMOS static RAM organized as 65,536 words by 16 bits. This device has an automatic power-down feature that significantly reduces power consumption when deselected.

Writing to the device is accomplished by taking Chip Enable (CE) and Write Enable (WE) inputs LOW. If Byte Low Enable (BLE) is LOW, then data from I/O pins (I/O₁ through I/O₈), is written into the location specified on the address pins (A₀ through A₁₅). If Byte High Enable (BHE) is LOW, then data from I/O pins (I/O₉ through I/O₁₆) is written into the location specified on the address pins (A₀ through A₁₅).

Reading from the device is accomplished by taking Chip Enable (CE) and Output Enable (OE) LOW while forcing the Write Enable (WE) HIGH. If Byte Low Enable (BLE) is LOW, then data from the memory location specified by the address pins will appear on I/O₁ to I/O₈. If Byte High Enable (BHE) is LOW, then data from memory will appear on I/O₉ to I/O₁₆. See the truth table at the back of this data sheet for a complete description of read and write modes.

The input/output pins (I/O₁ through I/O₁₆) are placed in a high-impedance state when the device is deselected (CE HIGH), the outputs are disabled (OE HIGH), the BHE and BLE are disabled (BHE, BLE HIGH), or during a write operation (CE LOW, and WE LOW).

The CY7C1021B/10211B is available in standard 44-pin TSOP Type II and 400-mil-wide SOJ packages. Customers should use part number CY7C10211B when ordering parts with 10-ns t_{AA} , and CY7C1021B when ordering 12- and 15-ns t_{AA} .

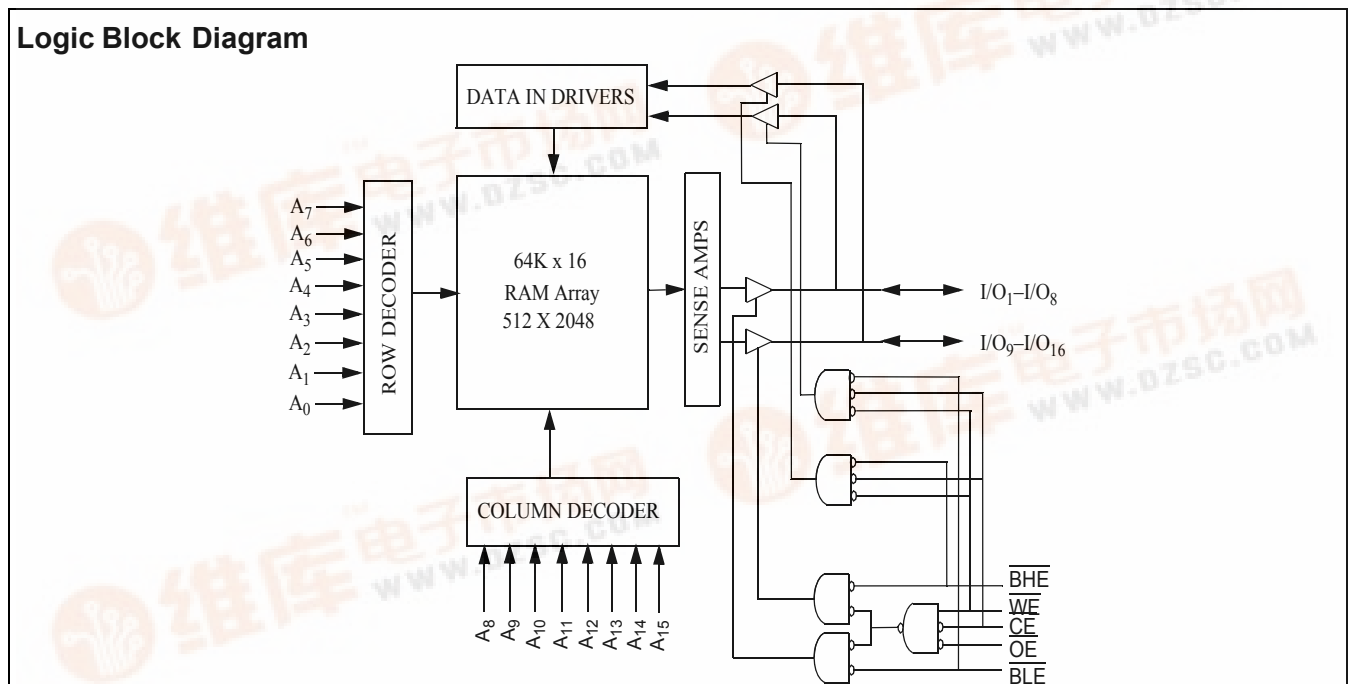

Note:

1. For best-practice recommendations, please refer to the Cypress application note "System Design Guidelines" on <http://www.cypress.com>.





Selection Guide

		7C10211B-10	7C1021B-12	7C1021B-15
Maximum Access Time (ns)		10	12	15
Maximum Operating Current (mA)	Com'l / Ind'l	150	140	130
	Automotive	-	-	150
Maximum CMOS Standby Current (mA)	Com'l / Ind'l	10	10	10
	Automotive	-	-	15
	L Version	0.5	0.5	0.5

Pin Configurations

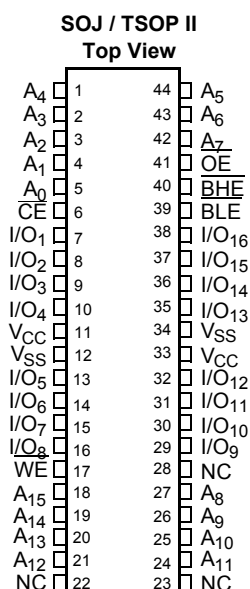

Pin Definitions

Pin Name	SOJ, TSOP–Pin Number	I/O Type	Description
A ₀ –A ₁₅	1–5, 18–21, 24–27, 42–44	Input	Address Inputs used to select one of the address locations.
I/O ₁ –I/O ₁₆	7–10, 13–16, 29–32, 35–38	Input/Output	Bidirectional Data I/O lines. Used as input or output lines depending on operation.
NC	22, 23, 28	No Connect	No Connects. Not connected to the die.
WE	17	Input/Control	Write Enable Input, active LOW. When selected LOW, a Write is conducted. When deselected HIGH, a Read is conducted.
CE	6	Input/Control	Chip Enable Input, active LOW. When LOW, selects the chip. When HIGH, deselects the chip.
BHE, BLE	39, 40	Input/Control	Byte Write Select Inputs, active LOW. BLE controls I/O ₈ –I/O ₁ , BHE controls I/O ₁₆ –I/O ₉ .
OE	41	Input/Control	Output Enable, active LOW. Controls the direction of the I/O pins. When LOW, the I/O pins are allowed to behave as outputs. When deasserted HIGH, I/O pins are three-stated, and act as input data pins.
V _{SS}	12, 34	Ground	Ground for the device. Should be connected to ground of the system.
V _{CC}	11, 33	Power Supply	Power Supply inputs to the device.



Maximum Ratings

(Above which the useful life may be impaired. For user guidelines, not tested.)

Storage Temperature-65°C to +150°C
 Ambient Temperature with Power Applied.....-55°C to +125°C
 Supply Voltage on V_{CC} to Relative GND^[2]-0.5V to +7.0V
 DC Voltage Applied to Outputs in High Z State^[2].....-0.5V to V_{CC}+0.5V
 DC Input Voltage^[2].....-0.5V to V_{CC}+0.5V
 Current into Outputs (LOW).....20 mA

Static Discharge Voltage.....>2001V (per MIL-STD-883, Method 3015)

Latch-Up Current.....>200 mA

Operating Range

Range	Ambient Temperature (T _A) ^[3]	V _{CC}
Commercial	0°C to +70°C	5V ± 10%
Industrial	-40°C to +85°C	5V ± 10%
Automotive	-40°C to +125°C	5V ± 10%

Electrical Characteristics Over the Operating Range

Parameter	Description	Test Conditions	7C10211B-10		7C1021B-12		7C1021B-15		Unit		
			Min.	Max.	Min.	Max.	Min.	Max.			
V _{OH}	Output HIGH Voltage	V _{CC} = Min., I _{OH} = -4.0 mA	2.4		2.4		2.4		V		
V _{OL}	Output LOW Voltage	V _{CC} = Min., I _{OL} = 8.0 mA		0.4		0.4		0.4	V		
V _{IH}	Input HIGH Voltage		2.2	6.0	2.2	6.0	2.2	6.0	V		
V _{IL}	Input LOW Voltage ^[2]		-0.5	0.8	-0.5	0.8	-0.5	0.8	V		
I _{IX}	Input Load Current	GND ≤ V _I ≤ V _{CC}	Com'l / Ind'l		-1	+1	-1	+1	-1	+1	μA
			Automotive		-	-	-	-	-4	+4	μA
I _{OZ}	Output Leakage Current	GND ≤ V _I ≤ V _{CC} , Output Disabled	Com'l / Ind'l		-1	+1	-1	+1	-1	+1	μA
			Automotive		-	-	-	-	-4	+4	μA
I _{OS}	Output Short Circuit Current ^[4]	V _{CC} = Max., V _{OUT} = GND		-300		-300		-300	mA		
I _{CC}	V _{CC} Operating Supply Current	V _{CC} = Max., I _{OUT} = 0 mA, f = f _{MAX} = 1/t _{RC}	Com'l / Ind'l			150		140		130	mA
			Automotive			-		-		150	mA
I _{SB1}	Automatic CE Power-Down Current—TTL Inputs	Max. V _{CC} , $\overline{CE} \geq V_{IH}$, V _{IN} ≥ V _{IH} or V _{IN} ≤ V _{IL} , f = f _{MAX}	Com'l / Ind'l			40		40		40	mA
			Automotive			-		-		50	mA
I _{SB2}	Automatic CE Power-Down Current—CMOS Inputs	Max. V _{CC} , $\overline{CE} \geq V_{CC} - 0.3V$, V _{IN} ≥ V _{CC} - 0.3V, or V _{IN} ≤ 0.3V, f = 0	Com'l / Ind'l			10		10		10	mA
			Automotive			-		-		15	mA
			L Version			0.5		0.5		0.5	mA

Thermal Resistance^[5]

Parameter	Description	Test Conditions	44-lead SOJ	44-lead TSOP-II	Unit
θ _{JA}	Thermal Resistance (Junction to Ambient)	Test conditions follow standard test methods and procedures for measuring thermal impedance, per EIA / JESD51.	64.32	76.89	°C/W
θ _{JC}	Thermal Resistance (Junction to Case)		31.03	14.28	°C/W

Notes:

- V_{IL} (min.) = -2.0V and V_{IH} (max) = V_{CC} + 0.5V for pulse durations of less than 20 ns.
- T_A is the "Instant On" case temperature.
- Not more than one output should be shorted at one time. Duration of the short circuit should not exceed 30 seconds.
- Tested initially and after any design or process changes that may affect these parameters.

Capacitance^[5]

Parameter	Description	Test Conditions	Max.	Unit
C _{IN}	Input Capacitance	T _A = 25°C, f = 1 MHz, V _{CC} = 5.0V	8	pF
C _{OUT}	Output Capacitance		8	pF

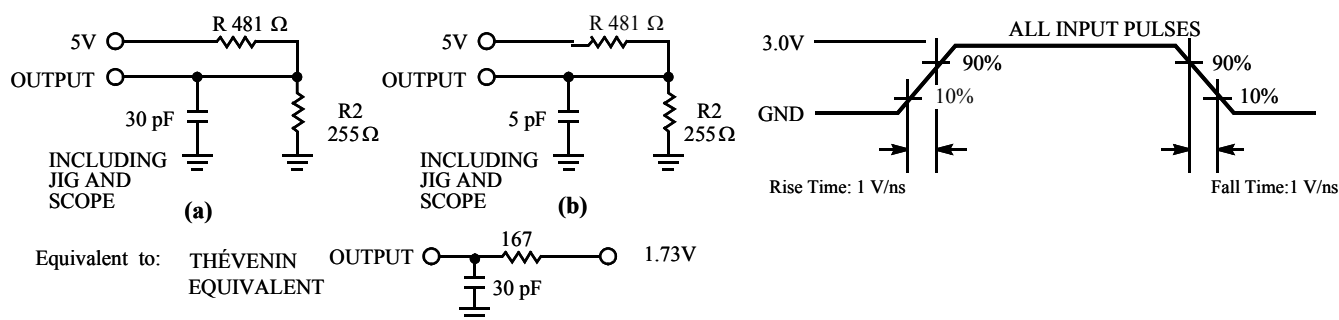
AC Test Loads and Waveforms

Switching Characteristics^[6] Over the Operating Range

Parameter	Description	7C10211B-10		7C1021B-12		7C1021B-15		Unit
		Min.	Max.	Min.	Max.	Min.	Max.	
Read Cycle								
t _{RC}	Read Cycle Time	10		12		15		ns
t _{AA}	Address to Data Valid		10		12		15	ns
t _{OHA}	Data Hold from Address Change	3		3		3		ns
t _{ACE}	$\overline{\text{CE}}$ LOW to Data Valid		10		12		15	ns
t _{DOE}	$\overline{\text{OE}}$ LOW to Data Valid		5		6		7	ns
t _{LZOE}	$\overline{\text{OE}}$ LOW to Low Z ^[7]	0		0		0		ns
t _{HZOE}	$\overline{\text{OE}}$ HIGH to High Z ^[7, 8]		5		6		7	ns
t _{LZCE}	$\overline{\text{CE}}$ LOW to Low Z ^[7]	3		3		3		ns
t _{HZCE}	$\overline{\text{CE}}$ HIGH to High Z ^[7, 8]		5		6		7	ns
t _{PU}	$\overline{\text{CE}}$ LOW to Power-Up	0		0		0		ns
t _{PD}	$\overline{\text{CE}}$ HIGH to Power-Down		10		12		15	ns
t _{DBE}	Byte Enable to Data Valid		5		6		7	ns
t _{LZBE}	Byte Enable to Low Z	0		0		0		ns
t _{HZBE}	Byte Disable to High Z		5		6		7	ns
Write Cycle^[9]								
t _{WC}	Write Cycle Time	10		12		15		ns
t _{SCE}	$\overline{\text{CE}}$ LOW to Write End	8		9		10		ns
t _{AW}	Address Set-Up to Write End	7		8		10		ns
t _{HA}	Address Hold from Write End	0		0		0		ns
t _{SA}	Address Set-Up to Write Start	0		0		0		ns
t _{SD}	Data Set-Up to Write End	5		6		8		ns
t _{HD}	Data Hold from Write End	0		0		0		ns

Notes:

- Test conditions assume signal transition time of 3 ns or less, timing reference levels of 1.5V, input pulse levels of 0 to 3.0V, and output loading of the specified I_{OL}/I_{OH} and 30-pF load capacitance.
- At any given temperature and voltage condition, t_{HZCE} is less than t_{LZCE}, t_{HZOE} is less than t_{LZOE}, and t_{HZWE} is less than t_{LZWE} for any given device.
- t_{HZOE}, t_{HZBE}, t_{HZCE}, and t_{HZWE} are specified with a load capacitance of 5 pF as in part (b) of AC Test Loads. Transition is measured ±500 mV from steady-state voltage.
- The internal write time of the memory is defined by the overlap of $\overline{\text{CE}}$ LOW, $\overline{\text{WE}}$ LOW and BHE / BLE LOW. $\overline{\text{CE}}$, $\overline{\text{WE}}$ and BHE / BLE must be LOW to initiate a write, and the transition of these signals can terminate the write. The input data set-up and hold timing should be referenced to the leading edge of the signal that terminates the write.



Switching Characteristics^[6] Over the Operating Range (continued)

Parameter	Description	7C10211B-10		7C1021B-12		7C1021B-15		Unit
		Min.	Max.	Min.	Max.	Min.	Max.	
t_{LZWE}	\overline{WE} HIGH to Low Z ^[7]	3		3		3		ns
t_{HZWE}	\overline{WE} LOW to High Z ^[7, 8]		5		6		7	ns
t_{BW}	Byte Enable to End of Write	7		8		9		ns

Switching Waveforms

Read Cycle No. 1 ^[10, 11]

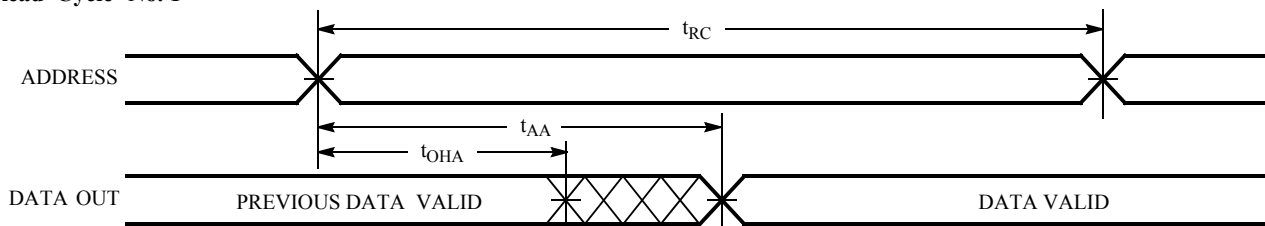

Read Cycle No. 2 (\overline{OE} Controlled) ^[11, 12]

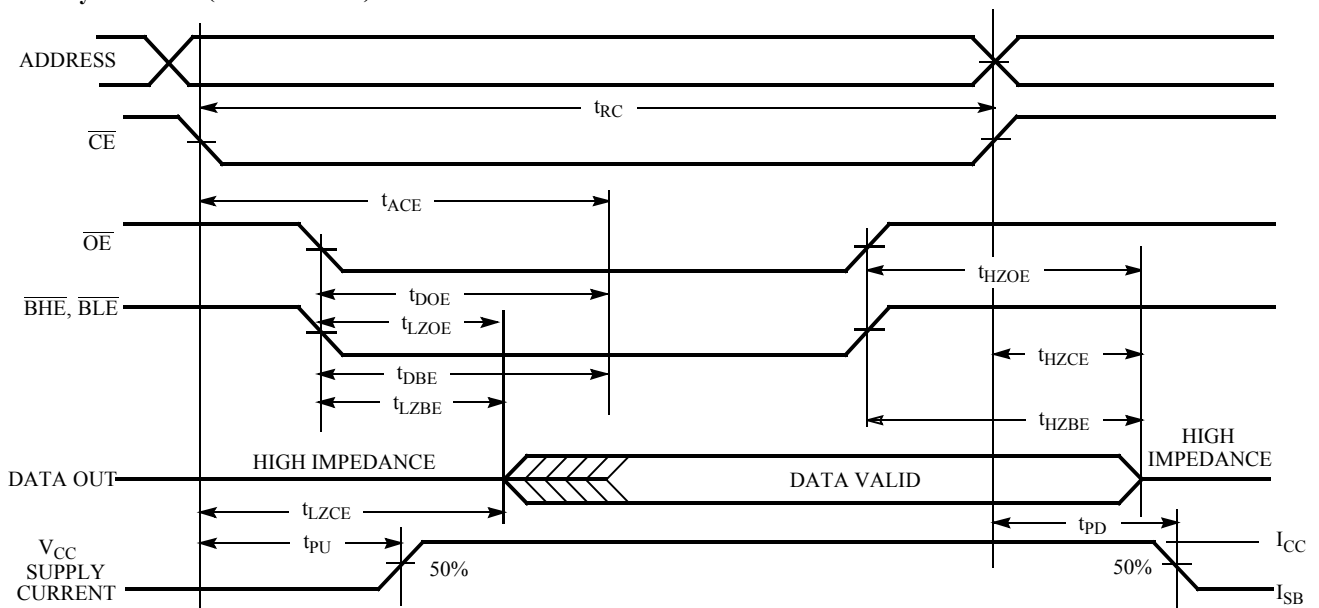

Notes:

- 10. Device is continuously selected. \overline{OE} , \overline{CE} , \overline{BHE} and/or \overline{BLE} = V_{IL} .
- 11. \overline{WE} is HIGH for read cycle.

Switching Waveforms (continued)

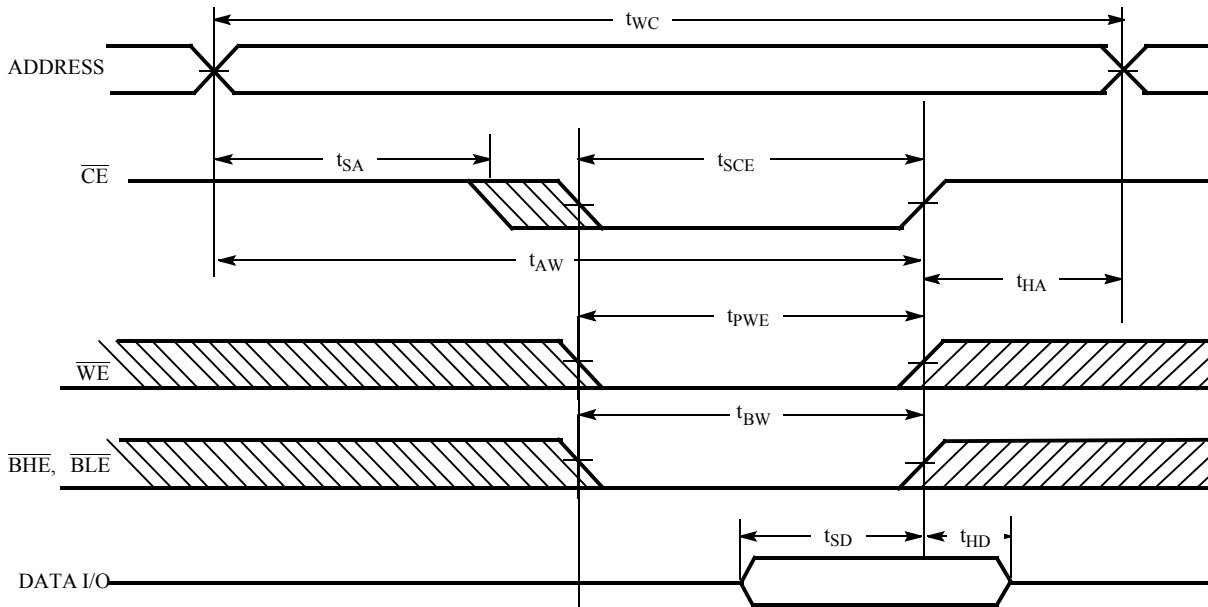
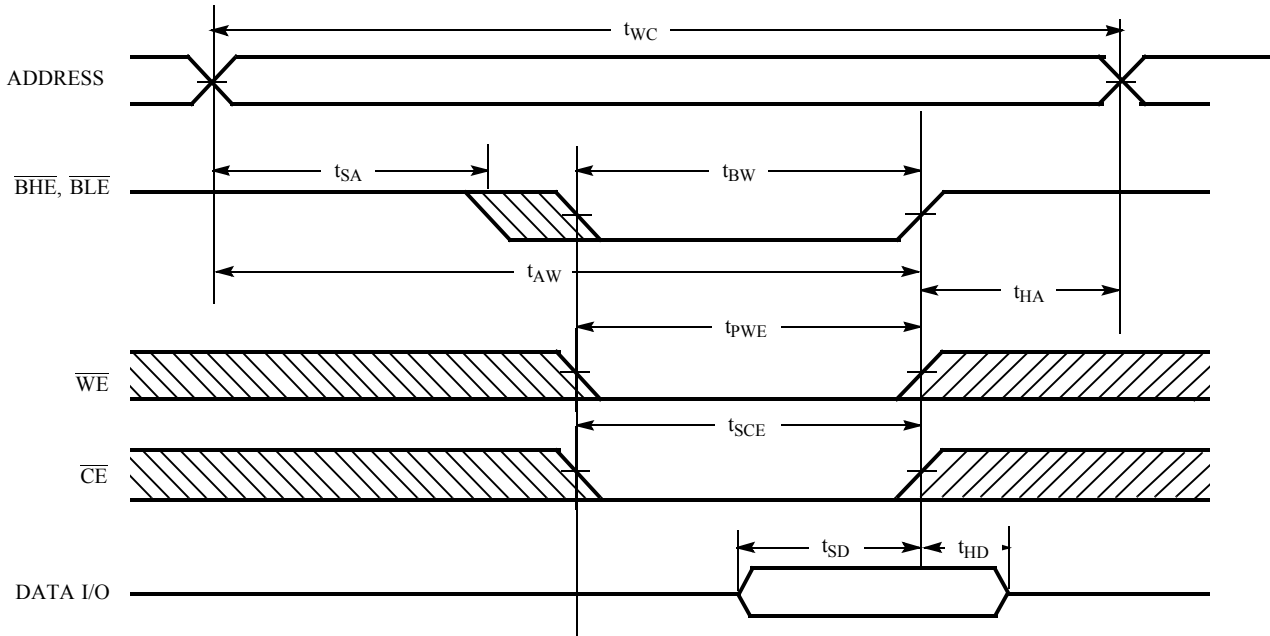
Write Cycle No. 1 (\overline{CE} Controlled) [13, 14]

Write Cycle No. 2 (\overline{BLE} or \overline{BHE} Controlled)

Notes:

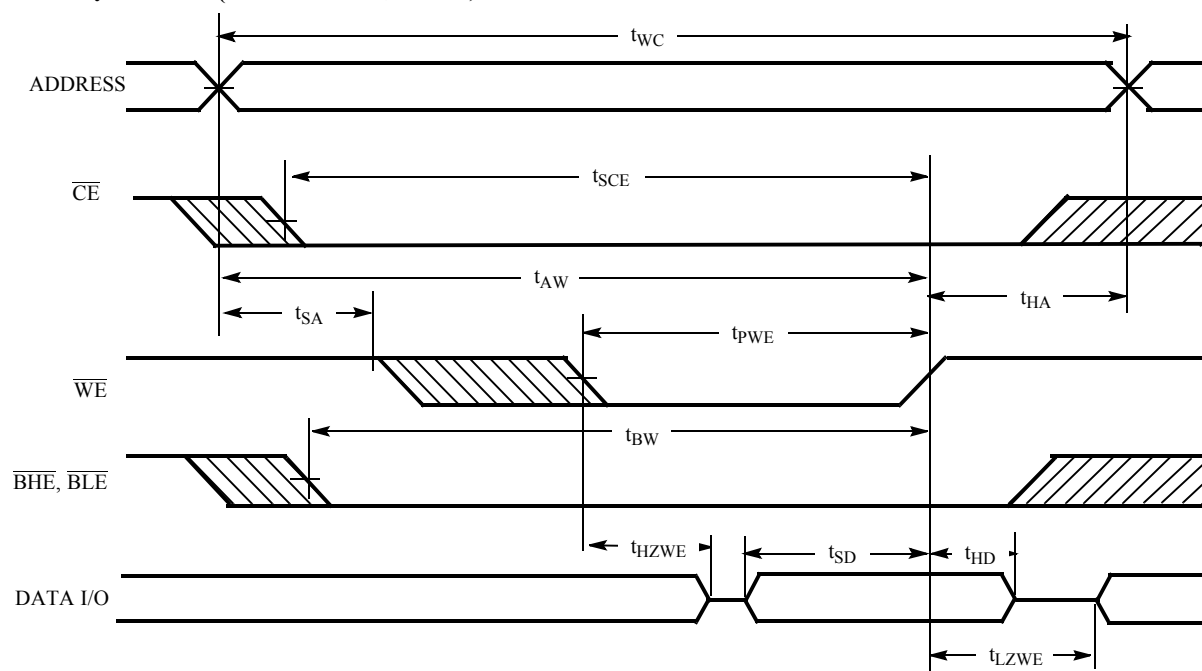
12. Address valid prior to or coincident with \overline{CE} transition LOW.
13. Data I/O is high impedance if \overline{OE} or \overline{BHE} and/or $\overline{BLE} = V_{IH}$.
14. If \overline{CE} goes HIGH simultaneously with \overline{WE} going HIGH, the output remains in a high-impedance state.

Switching Waveforms (continued)

Write Cycle No. 3 (\overline{WE} Controlled, LOW)

Truth Table

\overline{CE}	\overline{OE}	\overline{WE}	\overline{BLE}	\overline{BHE}	I/O ₁ -I/O ₈	I/O ₉ -I/O ₁₆	Mode	Power
H	X	X	X	X	High Z	High Z	Power-Down	Standby (I _{SB})
L	L	H	L	L	Data Out	Data Out	Read - All bits	Active (I _{CC})
			L	H	Data Out	High Z	Read - Lower bits only	Active (I _{CC})
			H	L	High Z	Data Out	Read - Upper bits only	Active (I _{CC})
L	X	L	L	L	Data In	Data In	Write - All bits	Active (I _{CC})
			L	H	Data In	High Z	Write - Lower bits only	Active (I _{CC})
			H	L	High Z	Data In	Write - Upper bits only	Active (I _{CC})
L	H	H	X	X	High Z	High Z	Selected, Outputs Disabled	Active (I _{CC})
L	X	X	H	H	High Z	High Z	Selected, Outputs Disabled	Active (I _{CC})

Ordering Information

Speed (ns)	Ordering Code	Package Name	Package Type	Operating Range
10	CY7C10211B-10VC	V34	44-Lead (400-Mil) Molded SOJ	Commercial
	CY7C10211B-10ZC	Z44	44-Lead TSOP Type II	Commercial
	CY7C10211BL-10ZC	Z44	44-Lead TSOP Type II	Commercial
12	CY7C1021B-12VC	V34	44-Lead (400-Mil) Molded SOJ	Commercial
	CY7C1021B-12VI	V34	44-Lead (400-Mil) Molded SOJ	Industrial
	CY7C1021BL-12VC	V34	44-Lead (400-Mil) Molded SOJ	Commercial
	CY7C1021B-12ZC	Z44	44-Lead TSOP Type II	Commercial
	CY7C1021B-12ZI	Z44	44-Lead TSOP Type II	Industrial
	CY7C1021BL-12ZC	Z44	44-Lead TSOP Type II	Commercial



Ordering Information (continued)

Speed (ns)	Ordering Code	Package Name	Package Type	Operating Range
15	CY7C1021B-15VC	V34	44-pin (400-Mil) Molded SOJ	Commercial
	CY7C1021B-15VI	V34	44-pin (400-Mil) Molded SOJ	Industrial
	CY7C1021BL-15VC	V34	44-pin (400-Mil) Molded SOJ	Commercial
	CY7C1021B-15VE	V34	44-pin (400-Mil) Molded SOJ	Automotive
	CY7C1021B-15ZC	Z44	44-pin TSOP Type II	Commercial
	CY7C1021B-15ZXC	Z44	Lead (Pb)-Free, 44-pin TSOP Type II	Commercial
	CY7C1021B-15ZI	Z44	44-pin TSOP Type II	Industrial
	CY7C1021BL-15ZC	Z44	44-pin TSOP Type II	Commercial
	CY7C1021B-15ZE	Z44	44-pin TSOP Type II	Automotive

Package Diagrams

44-Lead (400-Mil) Molded SOJ V34

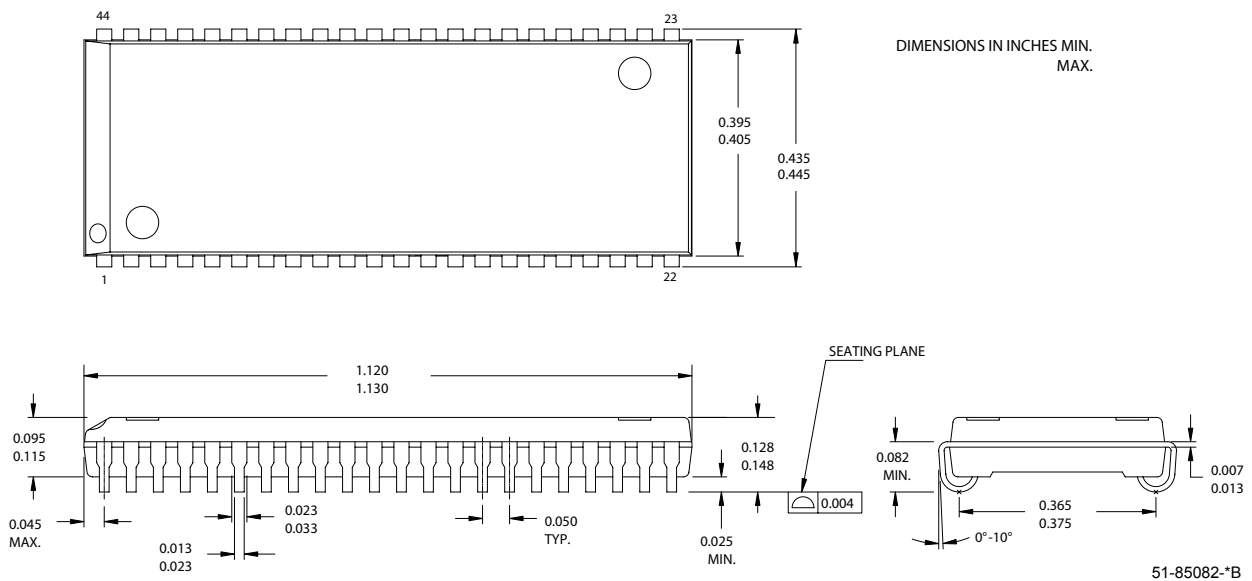

Package Diagrams (continued)

44-Pin TSOP II Z44

DIMENSION IN MM (INCH)
 MAX
 MIN

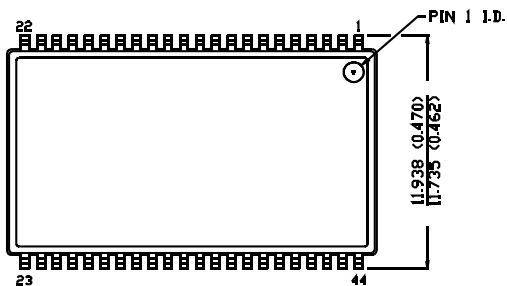

TOP VIEW

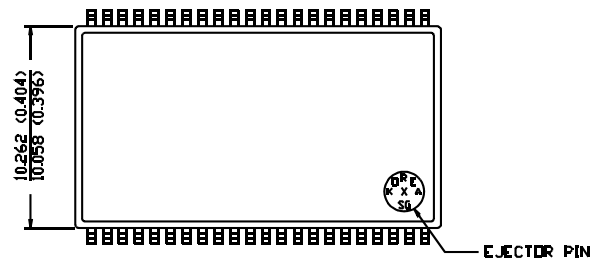

BOTTOM VIEW

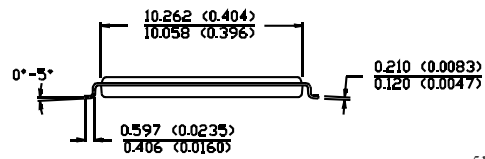
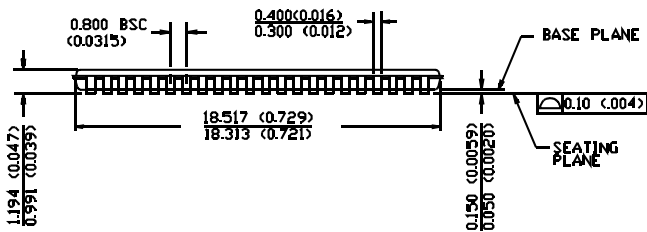

51-85087-*A

All products and company names mentioned in this document may be the trademarks of their respective holders.



CY7C1021B
CY7C10211B

Document History Page

Document Title: CY7C1021B/CY7C10211B 64K x 16 Static RAM				
Document Number: 38-05145				
REV.	ECN NO.	Issue Date	Orig. of Change	Description of Change
**	109889	09/22/01	SZV	Change from Spec number: 38-00951 to 38-05145
*A	238454	See ECN	RKF	1) Added Automotive Specs to Data Sheet 2) Added Pb-Free device offering in the Ordering Information