

<b>SANYO</b>	No.829H	<b>2SA1481/2SC2960</b>
		PNP/NPN Epitaxial Planar Silicon Transistors
<b>High-Speed Switching Applications</b>		

**Features**

- . Fast switching speed
- . High breakdown voltage

( ): 2SA1481

**Absolute Maximum Ratings at Ta=25°C**

			unit
Collector to Base Voltage	$V_{CB0}$	(-)60	V
Collector to Emitter Voltage	$V_{CEO}$	(-)50	V
Emitter to Base Voltage	$V_{EBO}$	(-)5	V
Collector Current	$I_C$	(-)150	mA
Collector Current(Pulse)	$I_{CP}$	(-)400	mA
Collector Dissipation	$P_C$	250	mW
Junction Temperature	$T_j$	150	°C
Storage Temperature	$T_{stg}$	-55 to +150	°C

**Electrical Characteristics at Ta=25°C**

		min	typ	max	unit
Collector Cutoff Current	$I_{CBO}$ $V_{CB}=(-)40V, I_E=0$			(-)0.1	$\mu A$
Emitter Cutoff Current	$I_{EBO}$ $V_{EB}=(-)4V, I_C=0$			(-)0.1	$\mu A$
DC Current Gain	$h_{FE}$ $V_{CE}=(-)6V, I_C=(-)1mA$	100*		560*	
Gain-Bandwidth Product	$f_T$ $V_{CE}=(-)6V, I_C=(-)1mA$		100		MHz
Output Capacitance	$c_{ob}$ $V_{CB}=(-)6V, f=1MHz$		2.7(4.0)		pF
C-E Saturation Voltage	$V_{CE(sat)}$ $I_C=(-)10mA, I_B=(-)1mA$		(-)0.1	(-)0.4	V
B-E Saturation Voltage	$V_{BE(sat)}$ $I_C=(-)10mA, I_B=(-)1mA$		(-)0.75	(-)1.1	V
C-B Breakdown Voltage	$V_{(BR)CBO}$ $I_C=(-)10\mu A, I_E=0$	(-)60			V
C-E Breakdown Voltage	$V_{(BR)CEO}$ $I_C=(-)1mA, R_{BE}=\infty$	(-)50			V
E-B Breakdown Voltage	$V_{(BR)EBO}$ $I_E=(-)10\mu A, I_C=0$	(-)5			V
Delay Time	$t_d$ See specified Test Circuit.		40	60	ns
Rise Time	$t_r$ "		80(120)	130(230)	ns
Storage Time	$t_{stg}$ "		230(190)	450(700)	ns
Fall Time	$t_f$ "		160(240)	250(390)	ns

\*: The 2SA1481/2SC2960 are classified by 1mA  $h_{FE}$  as follows:

100	E	200	160	F	320	280	G	560
-----	---	-----	-----	---	-----	-----	---	-----

**Switching Time Test Circuit**

(For PNP, the polarity is reversed.)

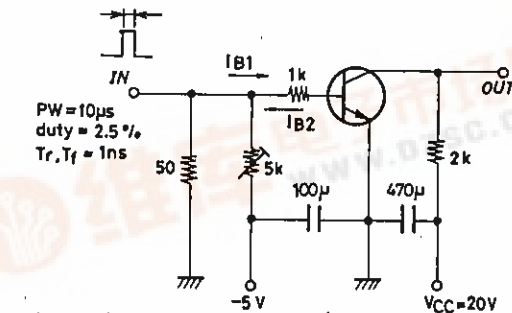

10 I<sub>B1</sub> = -10 I<sub>B2</sub> = I<sub>C</sub> = 10mA

Unit(Resistance:  $\Omega$ , Capacitance: F)

**Package Dimensions 2033**

(unit: mm)

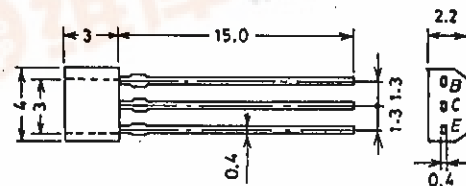

B: Base  
C: Collector  
E: Emitter  
SANYO: SPA



2SA1481/2SC2960

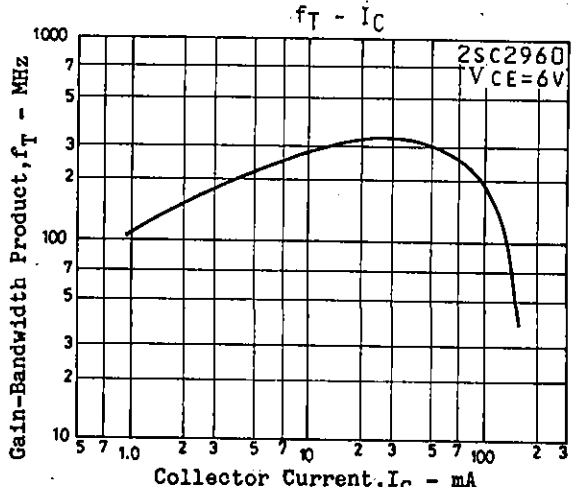
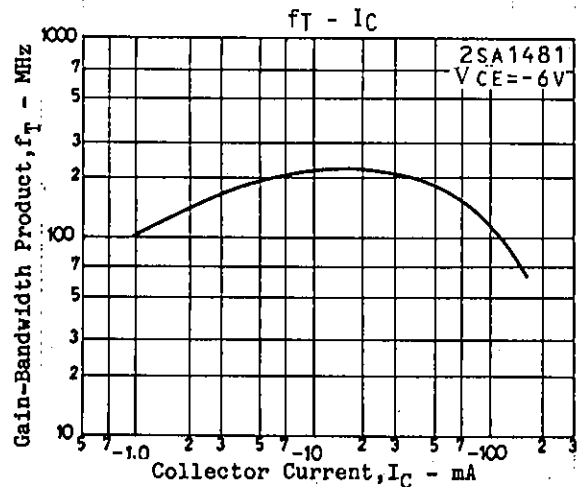
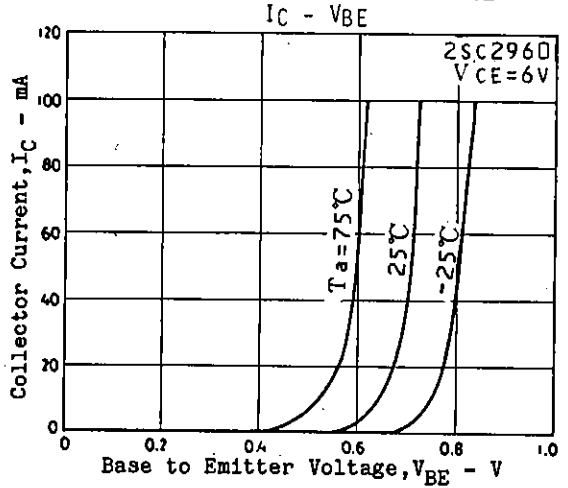
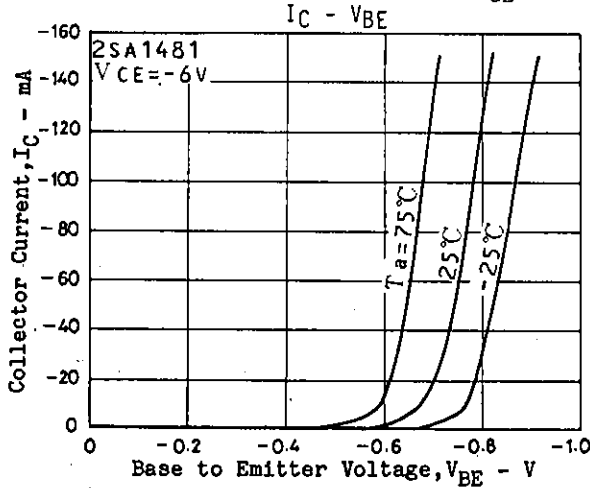
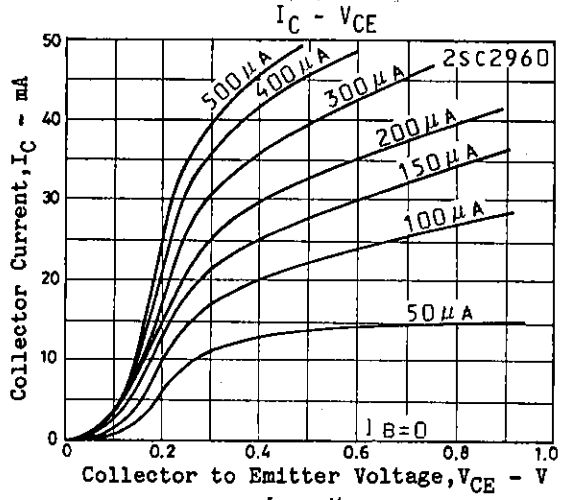
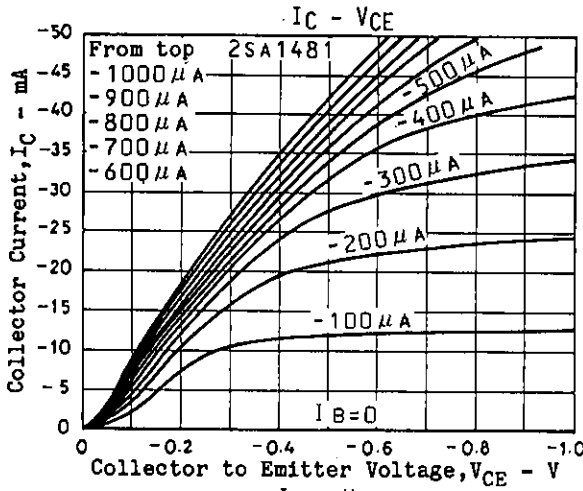
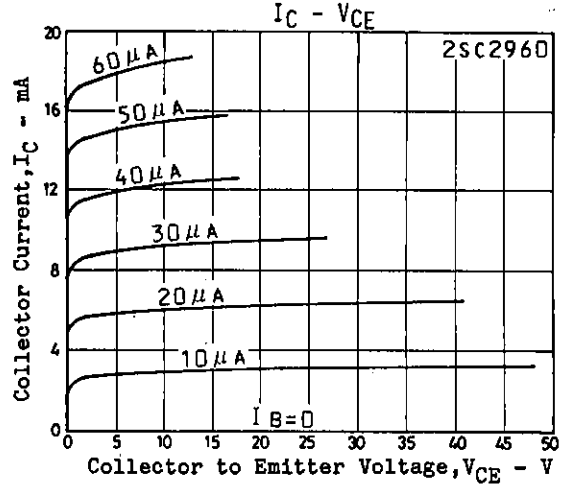
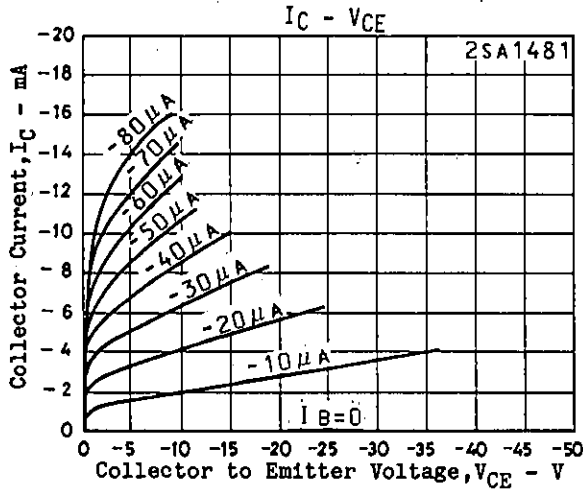

2SA1481/2SC2960

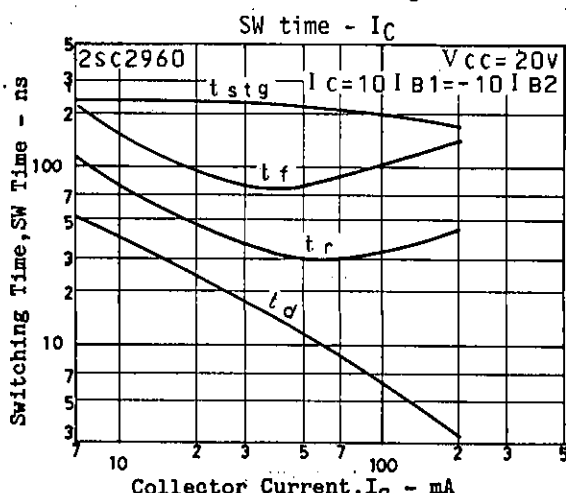
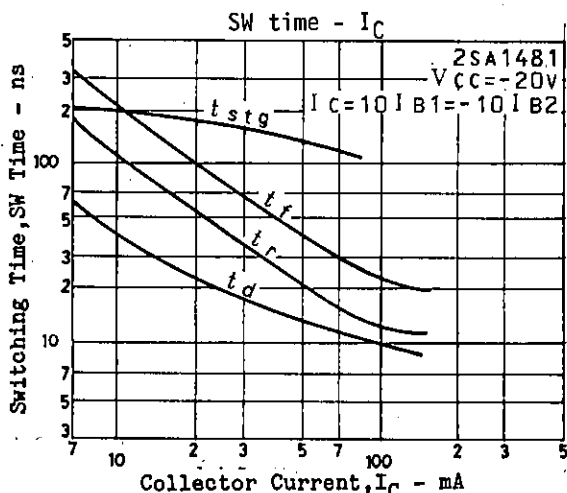
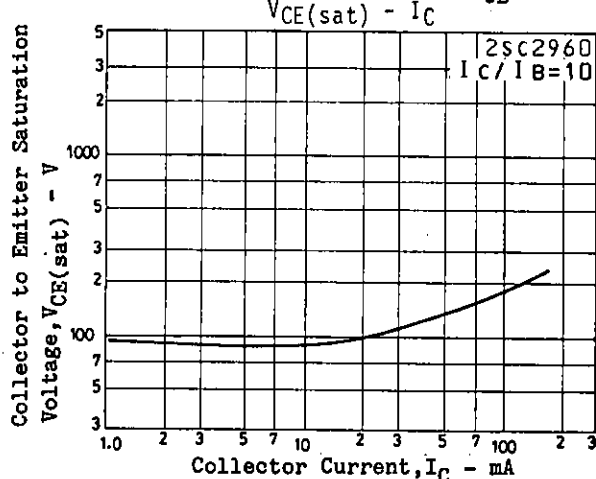
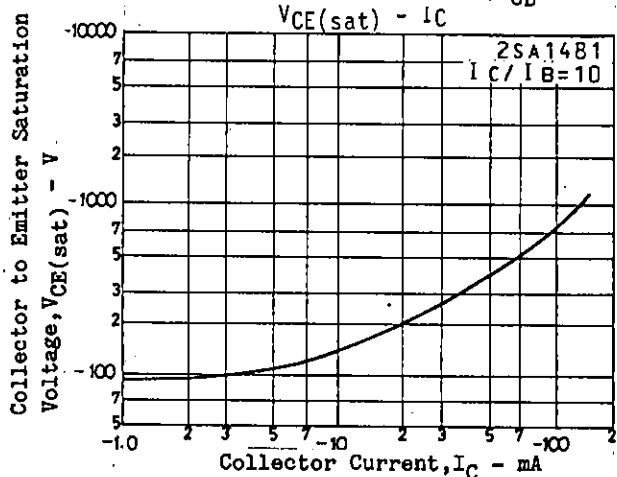
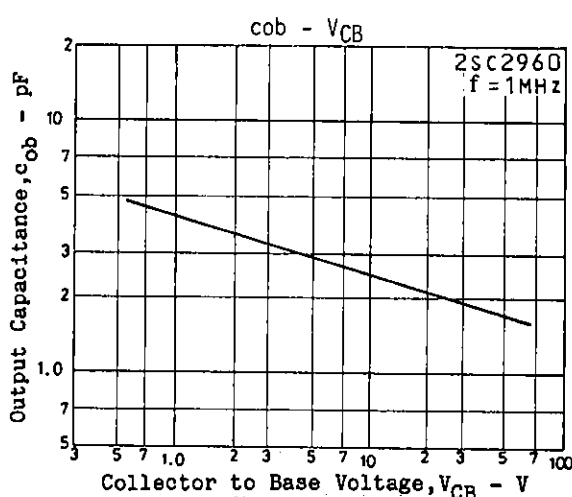
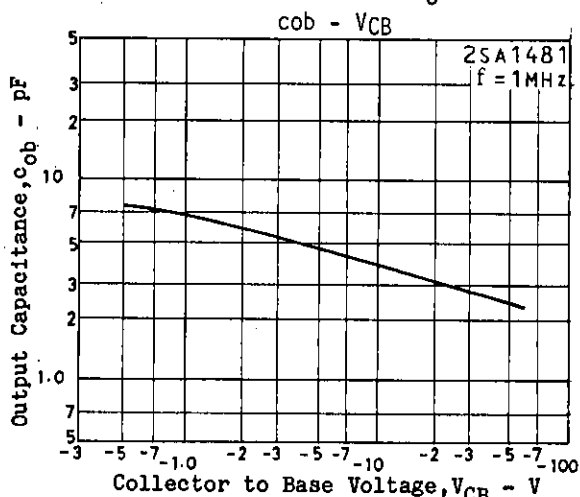
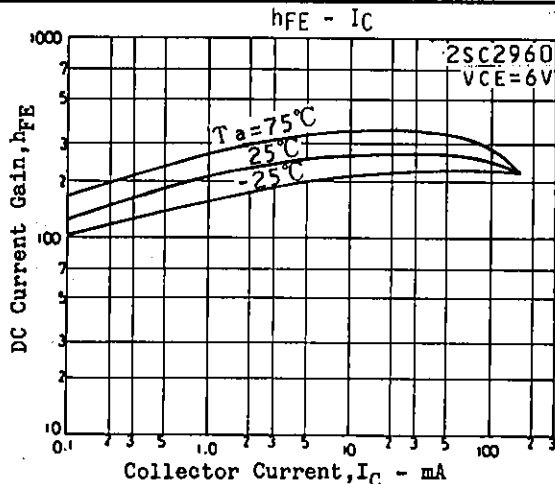
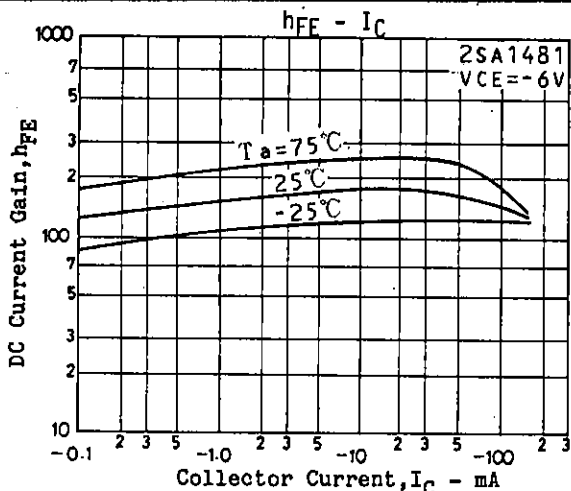

## 2SA1481/2SC2960

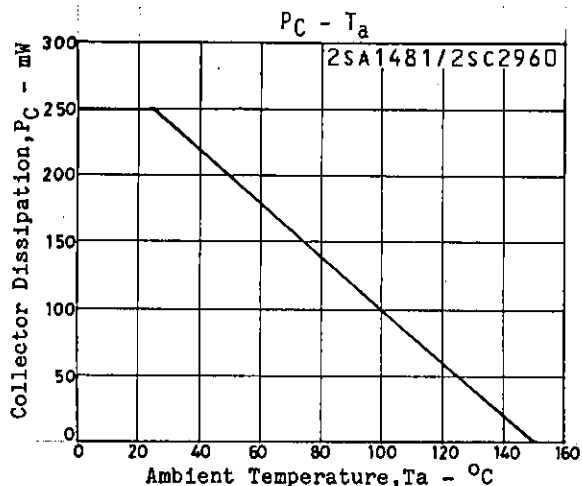
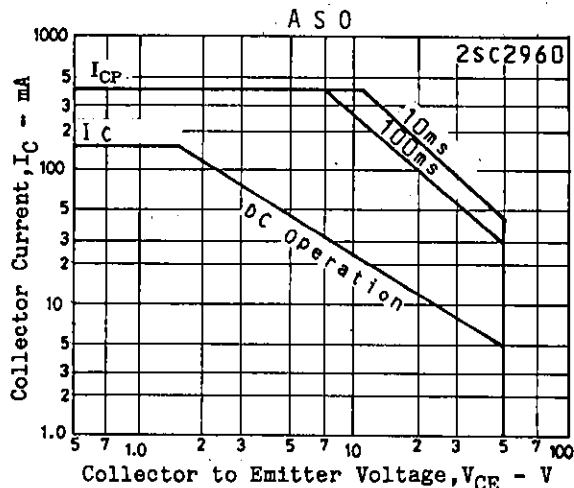
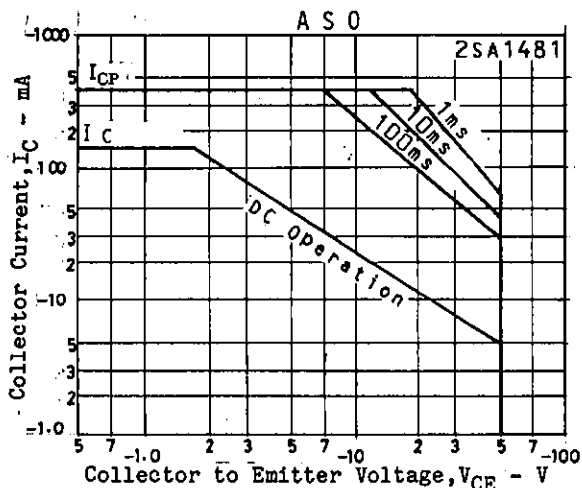

- No products described or contained herein are intended for use in surgical implants, life-support systems, aerospace equipment, nuclear power control systems, vehicles, disaster/crime-prevention equipment and the like, the failure of which may directly or indirectly cause injury, death or property loss.
- Anyone purchasing any products described or contained herein for an above-mentioned use shall:
  - ① Accept full responsibility and indemnify and defend SANYO ELECTRIC CO., LTD., its affiliates, subsidiaries and distributors and all their officers and employees, jointly and severally, against any and all claims and litigation and all damages, cost and expenses associated with such use:
  - ② Not impose any responsibility for any fault or negligence which may be cited in any such claim or litigation on SANYO ELECTRIC CO., LTD., its affiliates, subsidiaries and distributors or any of their officers and employees jointly or severally.
- Information (including circuit diagrams and circuit parameters) herein is for example only; it is not guaranteed for volume production. SANYO believes information herein is accurate and reliable, but no guarantees are made or implied regarding its use or any infringements of intellectual property rights or other rights of third parties.