



**Integrated
Circuit
Systems, Inc.**

ICS9148-58

Frequency Generator & Integrated Buffers for PENTIUM/Pro™

General Description

The ICS9148-58 is the single chip clock solution for Desktop/ Notebook designs using the VIA MVP3 style chipset. It provides all necessary clock signals for such a system.

Spread spectrum may be enabled through I2C programming. Spread spectrum typically reduces system EMI by 8dB to 10dB. This simplifies EMI qualification without resorting to board design iterations or costly shielding. The ICS9148-58 employs a proprietary closed loop design, which tightly controls the percentage of spreading over process and temperature variations.

Serial programming I²C interface allows changing functions, stop clock programming and frequency selection. The SD_SEL latched input allows the SDRAM frequency to follow the CPUCLK frequency(SD_SEL=1) or the AGP clock frequency(SD_SEL=0)

Block Diagram

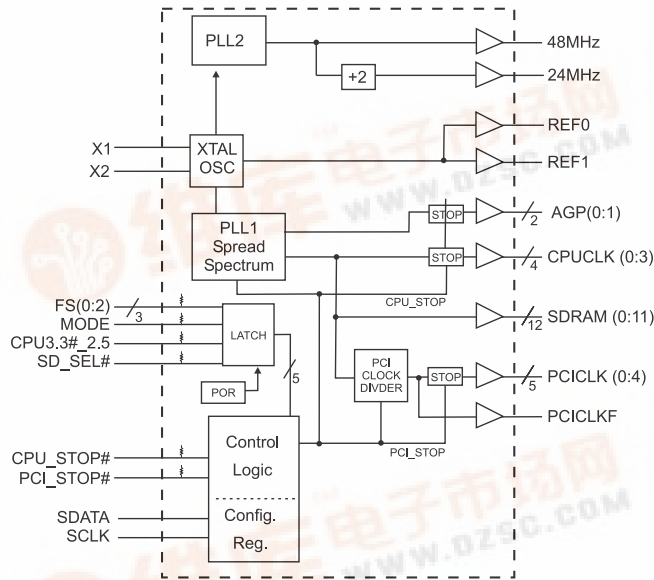

Power Groups

- VDD1 = REF (0:1), X1, X2
- VDD2 = PCICLK_F, PCICLK(0:5)
- VDD3 = SDRAM (0:11), supply for PLL core, 24 MHz, 48MHz
- VDD4 = AGP (0:1)
- VDDL = CPUCLK(0:3)

Features

- Generates the following system clocks:
 - 4 CPU(2.5V/3.3V) upto 100MHz.
 - 6 PCI(3.3V) @ 33.3MHz
 - 2AGP(3.3V) @ 2x PCI
 - 12 SDRAMs(3.3V) @ either CPU or AGP
 - 2 REF(3.3V) @ 14.318MHz
- Skew characteristics:
 - CPU – CPU ≤ 250ps
 - SDRAM – SDRAM ≤ 250ps
 - CPU – SDRAM ≤ 250ps
 - CPU(early) – PCI : 1-4ns
- Spread Spectrum 0 to -5% down spread.
- Serial I²C interface for Power Management, Frequency Select, Spread Spectrum.
- Efficient Power management scheme through PCI and CPU STOPCLOCKS.
- Uses external 14.318MHz crystal
- 48 pin 300mil SSOP.

Pin Configuration

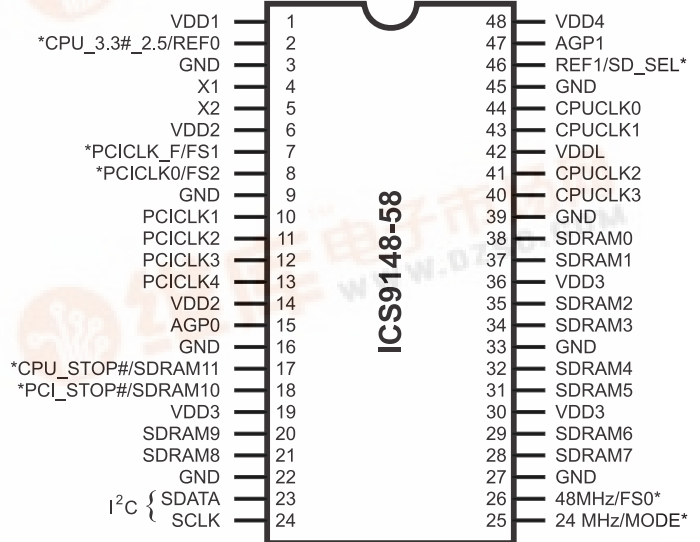

48-Pin SSOP

* Internal Pull-up Resistor of 240K to 3.3V on indicated inputs

ICS9148-58



Pin Descriptions

PIN NUMBER	PIN NAME	TYPE	DESCRIPTION
1	VDD1	PWR	Ref (0:2), XTAL power supply, nominal 3.3V
2	REF0	OUT	14.318 MHz reference clock.
	CPU3.3#_2.5 ^{1,2}	IN	Indicates whether VDDL2 is 3.3V or 2.5V. High=2.5V CPU, LOW=3.3V CPU ¹ . Latched input ²
3,9,16,22,27,33,39,45	GND	PWR	Ground
4	X1	IN	Crystal input, has internal load cap (33pF) and feedback resistor from X2
5	X2	OUT	Crystal output, nominally 14.318MHz. Has internal load cap (33pF)
6,14	VDD2	PWR	Supply for PCICLK_F and PCICLK (0:5), nominal 3.3V
7	PCICLK_F	OUT	Free running PCI clock output. Synchronous with CPUCLKs with 1-4ns skew (CPU early) This is not affected by PCI_STOP#
	FS1 ^{1,2}	IN	Frequency select pin. Latched Input. Along with other FS pins determines the CPU, SDRAM, PCI & AGP frequencies.
8	PCICLK0	OUT	PCI clock output. Synchronous CPUCLKs with 1-4ns skew (CPU early)
	FS2 ^{1,2}	IN	Frequency select pin. Latched Input Along with other FS pins determines the CPU, SDRAM, PCI & AGP frequencies.
10, 11, 12, 13	PCICLK(1:4)	OUT	PCI clock outputs. Synchronous CPUCLKs with 1-4ns skew (CPU early)
15, 47	AGP (0:1)	OUT	Advanced Graphic Port outputs, powered by VDD4.
17	CPU_STOP# ¹	IN	This asynchronous input halts CPUCLK (0:3) and AGP (0:1) clocks at logic 0 level, when input low (in Mobile Mode, MODE=0)
	SDRAM 11	OUT	SDRAM clock output. Frequency is selected by the SD_SEL latched input. SD_SEL = 1 at power on causes SDRAM frequency = CPU frequencies SD_SEL = 0 at power on causes SDRAM frequencies = AGP frequencies
18	PCI_STOP# ¹	IN	This asynchronous input halts PCICLK(0:5) clocks at logic 0 level, when input low (In mobile mode, MODE=0)
	SDRAM 10	OUT	SDRAM clock output. Frequency is selected by the SD_SEL latched input. SD_SEL = 1 at power on causes SDRAM frequency = CPU frequencies SD_SEL = 0 at power on causes SDRAM frequencies = AGP frequencies
20, 21,28, 29, 31, 32, 34, 35,37,38	SDRAM (0:9)	OUT	SDRAM clock outputs. Frequency is selected by the SD_SEL latched input. SD_SEL = 1 at power on causes SDRAM frequency = CPU frequencies SD_SEL = 0 at power on causes SDRAM frequencies = AGP frequencies
19,30,36	VDD3	PWR	Supply for SDRAM (0:11), CPU Core and 24, 48MHz clocks, nominal 3.3V.
23	SDATA	IN	Data input for I ² C serial input.
24	SCLK	IN	Clock input of I ² C input
25	24MHz	OUT	24MHz output clock, for Super I/O timing.
	MODE ^{1,2}	IN	Pin 17, pin 18 function select pin, 1=Desktop Mode, 0=Mobile Mode. Latched Input.
26	48MHz	OUT	48MHz output clock, for USB timing.
	FS0 ^{1,2}	IN	Frequency select pin. Latched Input Along with other FS pins determines the CPU, SDRAM, PCI & AGP frequencies.
40, 41, 43, 44	CPUCLK(0:3)	OUT	CPU clock outputs, powered by VDDL2. Low if CPU_STOP#=Low
42	VDDL	PWR	Supply for CPU (0:3), either 2.5V or 3.3V nominal
46	REF1	OUT	14.318MHz reference clock.
	SD_SEL	IN	Latched input at Power On selects either CPU (SDSEL=1) or AGP (SD_SEL=0) frequencies for the SDRAM clock outputs.
48	VDD4	PWR	Supply for AGP (0:1)

Notes:

- 1: Internal Pull-up Resistor of 240K to 3.3V on indicated inputs
- 2: Bidirectional input/output pins, input logic levels are latched at internal power-on-reset. Use 10Kohm resistor to program logic Hi to VDD or GND for logic low.



Mode Pin - Power Management Input Control

MODE, Pin 25 (Latched Input)	Pin 17	Pin 18
0	CPU_STOP# (INPUT)	PCI_STOP# (INPUT)
1	SDRAM 11 (OUTPUT)	SDRAM 10 (OUTPUT)

Power Management Functionality

CPU_STOP#	PCI_STOP#	AGP, CPUCLK Outputs	PCICLK (0:5)	PCICLK_F, REF, 24/48MHz and SDRAM	Crystal OSC	VCO
0	1	Stopped Low	Running	Running	Running	Running
1	1	Running	Running	Running	Running	Running
1	0	Running	Stopped Low	Running	Running	Running

CPU 3.3#_2.5V Buffer selector for CPUCLK drivers.

CPU3.3#_2.5 Input level (Latched Data)	Buffer Selected for operation at:
1	2.5V VDD
0	3.3V VDD

Functionality

V_{DD1,2,3,4} = 3.3V±5%, V_{DDL} = 2.5V±5% or 3.3±5%, TA=0 to 70°C
 Crystal (X1, X2) = 14.31818MHz

FS2	FS1	FS0	CPU (MHz)	SDRAM (MHz)		PCI (MHz)	AGP (MHz)
				SD_SEL=1	SD_SEL=0		
1	1	1	100.2	100.2	66.6	33.3	66.6
1	1	0	95.25	95.25	63.5	31.75	63.5
1	0	1	83.3	83.3	66.6	33.3	66.6
1	0	0	133.3	133.3	88.7	44.3	88.7
0	1	1	75	75	75	37.5	75
0	1	0	124	124	82.7	41.3	82.7
0	0	1	66.8	66.8	66.8	33.4	66.8
0	0	0	112	112	74.7	37.3	74.7



ICS9148-58

General I²C serial interface information

The information in this section assumes familiarity with I²C programming. For more information, contact ICS for an I²C programming application note.

How to Write:

- Send the address D2(H).
- Send two additional dummy bytes, a command code and byte count.
- Send the desired number of data bytes.

See the diagram below:

Clock Generator Address (7 bits)	ACK	+ 8 bits dummy command code	ACK	+ 8 bits dummy Byte count	ACK	Data Byte 1	ACK	Data Byte N	ACK
A(6:0) & R/W#									
D2(H)									

Note that the acknowledge bit is sent by the clock chip, and pulls the data line low. There is no minimum of data bytes that must be sent.

How to Read:

- Send the address D3(H).
- Send the byte count in binary coded decimal
- Read back the desired number of data bytes

See the diagram below:

Clock Generator Address (7 bits)	ACK	Byte Count	ACK	Data Byte 1	ACK	Data Byte N
A(6:0) & R/W#						
D3(H)						

The following specifications should be observed:

1. Operating voltage for I²C pins is 3.3V
2. Maximum data transfer rate (SCLK) is 100K bits/sec.

Note 1. Default at Power-up will be for latched logic inputs to define frequency. Bits 4, 5, 6 are default to 000, and if bit 3 is written to a 1 to use Bits 6:4, then these should be defined to desired frequency at same write cycle.

Note: PWD = Power-Up Default

I²C is a trademark of Philips Corporation

Serial Configuration Command Bitmap

Byte0: Functionality and Frequency Select Register (default = 0)

Bit	Description	PWD	
Bit 7	Reserved	0	
Bit 6:4	Bit6 Bit5 111	100.2 33.3 66.6	Note 1
	110	95.25 31.75 63.5	
	101	83.3 33.3 66.6	
	100	133.3 44.3 88.7	
	011	75 37.5 75	
	010	124 41.3 82.7	
	001	66.8 33.4 66.8	
	000	112 37.3 74.7	
Bit 3	0 - Frequency is selected by hardware select, Latched Inputs 1 - Frequency is selected by Bit 6:4 (above)	0	
Bit 2	0 - Spread Spectrum center spread type. ±.25% 1 - Spread Spectrum down spread type. 0 to -.5%	0	
Bit 1	0 - Normal 1 - Spread Spectrum Enabled	0	
Bit 0	0 - Running 1 - Tristate all outputs	0	



Byte 1: CPU, Active/Inactive Register (1 = enable, 0 = disable)

Bit	Pin #	PWD	Description
Bit 7	-	1	(Reserved)
Bit 6	-	1	(Reserved)
Bit 5	-	1	(Reserved)
Bit 4	-	1	(Reserved)
Bit 3	40	1	CPUCLK3 (Act/Inact)
Bit 2	41	1	CPUCLK2 (Act/Inact)
Bit 1	43	1	CPUCLK1 (Act/Inact)
Bit 0	44	1	CPUCLK0 (Act/Inact)

Notes:

1. Inactive means outputs are held LOW and are disabled from switching.

Byte 3: SDRAM Active/Inactive Register (1 = enable, 0 = disable)

Bit	Pin #	PWD	Description
Bit 7	28	1	SDRAM7 (Act/Inact)
Bit 6	29	1	SDRAM6 (Act/Inact)
Bit 5	31	1	SDRAM5 (Act/Inact)
Bit 4	32	1	SDRAM4 (Act/Inact)
Bit 3	34	1	SDRAM3 (Act/Inact)
Bit 2	35	1	SDRAM2 (Act/Inact)
Bit 1	37	1	SDRAM1 (Act/Inact)
Bit 0	38	1	SDRAM0 (Act/Inact)

Notes:

1. Inactive means outputs are held LOW and are disabled from switching.

Byte 5: Peripheral Active/Inactive Register (1 = enable, 0 = disable)

Bit	Pin #	PWD	Description
Bit 7	-	1	(Reserved)
Bit 6	-	1	(Reserved)
Bit 5	-	1	(Reserved)
Bit 4	47	1	AGP1 (Act/Inact)
Bit 3	-	1	(Reserved)
Bit 2	-	1	(Reserved)
Bit 1	46	1	REF1 (Act/Inact)
Bit 0	2	1	REF0 (Act/Inact)

Notes:

1. Inactive means outputs are held LOW and are disabled from switching.

Byte 2: PCI Active/Inactive Register (1 = enable, 0 = disable)

Bit	Pin #	PWD	Description
Bit 7	-	1	(Reserved)
Bit 6	7	1	PCICLK_F (Act/Inact)
Bit 5	15	1	AGP0 (Act/Inact)
Bit 4	14	1	PCICLK4 (Act/Inact)
Bit 3	12	1	PCICLK3 (Act/Inact)
Bit 2	11	1	PCICLK2 (Act/Inact)
Bit 1	10	1	PCICLK1 (Act/Inact)
Bit 0	8	1	PCICLK0 (Act/Inact)

Notes:

1. Inactive means outputs are held LOW and are disabled from switching.

Byte 4: SDRAM Active/Inactive Register (1 = enable, 0 = disable)

Bit	Pin #	PWD	Description
Bit 7	-	1	(Reserved)
Bit 6	-	1	(Reserved)
Bit 5	-	1	(Reserved)
Bit 4	-	1	(Reserved)
Bit 3	17	1	SDRAM11 (Act/Inact) (Desktop Mode Only)
Bit 2	18	1	SDRAM10 (Act/Inact) (Desktop Mode Only)
Bit 1	20	1	SDRAM9 (Act/Inact)
Bit 0	21	1	SDRAM8 (Act/Inact)

Notes:

1. Inactive means outputs are held LOW and are disabled from switching.



CPU_STOP# Timing Diagram

CPU_STOP# is an asynchronous input to the clock synthesizer. It is used to turn off the CPU clocks for low power operation. CPU_STOP# is synchronized by the ICS9148-58. The minimum that the CPU clock is enabled (CPU_STOP# high pulse) is 100 CPU clocks. All other clocks will continue to run while the CPU clocks are disabled. The CPU clocks will always be stopped in a low state and start in such a manner that guarantees the high pulse width is a full pulse. CPU clock on latency is less than 4 CPU clocks and CPU clock off latency is less than 4 CPU clocks.

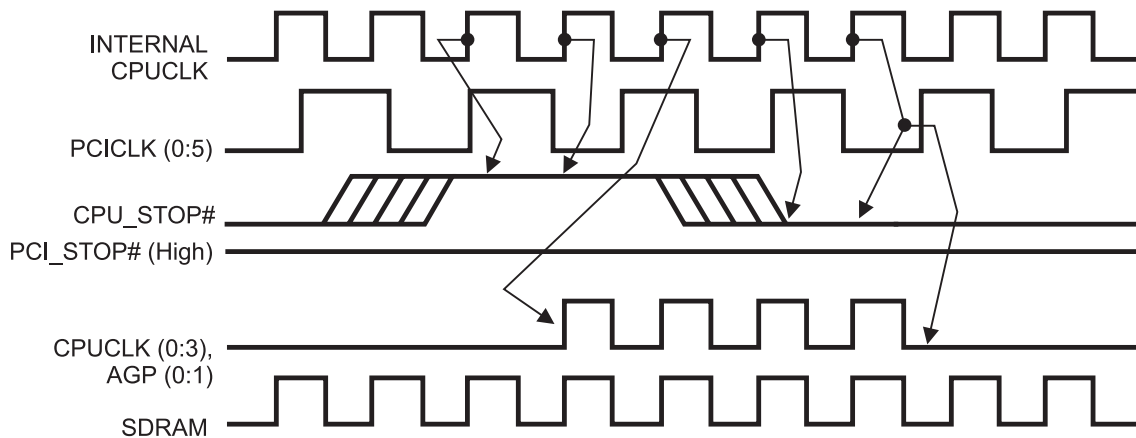

Notes:

1. All timing is referenced to the internal CPU clock.
2. CPU_STOP# is an asynchronous input and metastable conditions may exist. This signal is synchronized to the CPU clocks inside the ICS9148-58.
3. All other clocks continue to run undisturbed. (including SDRAM outputs).



PCI_STOP# Timing Diagram

PCI_STOP# is an asynchronous input to the ICS9148-58. It is used to turn off the PCICLK (0:5) clocks for low power operation. PCI_STOP# is synchronized by the ICS9148-58 internally. The minimum that the PCICLK (0:5) clocks are enabled (PCI_STOP# high pulse) is at least 10 PCICLK (0:5) clocks. PCICLK (0:5) clocks are stopped in a low state and started with a full high pulse width guaranteed. PCICLK (0:5) clock on latency cycles are only one rising PCICLK clock off latency is one PCICLK clock.

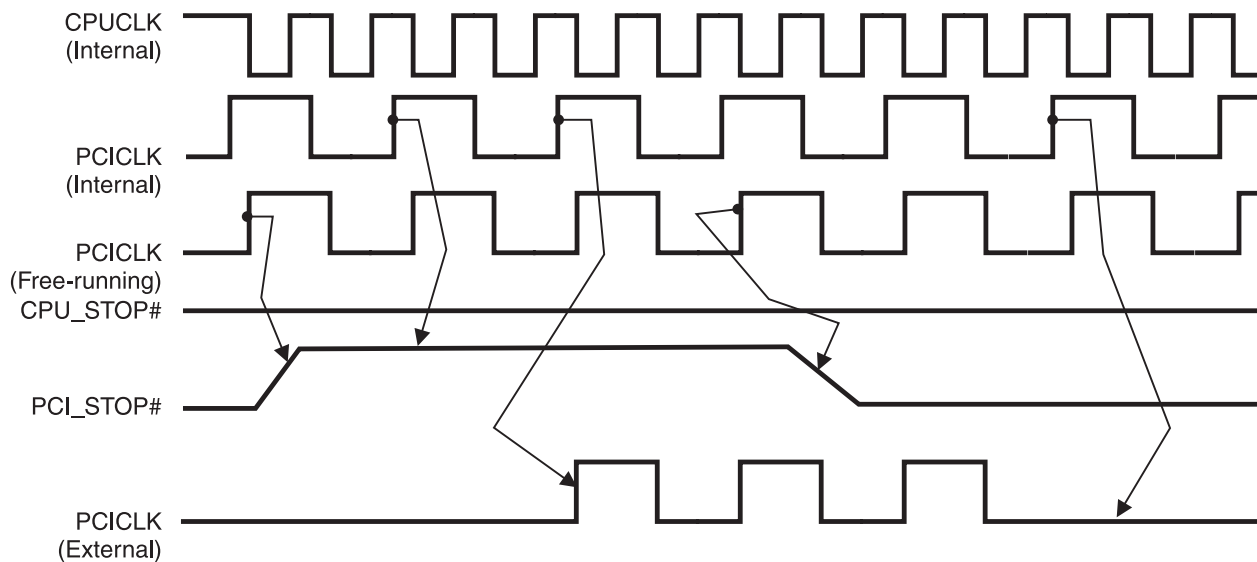

Notes:

1. All timing is referenced to the Internal CPUCLK (defined as inside the ICS9148 device.)
2. PCI_STOP# is an asynchronous input, and metastable conditions may exist. This signal is required to be synchronized inside the ICS9148.
3. All other clocks continue to run undisturbed.
4. CPU_STOP# is shown in a high (true) state.



ICS9148-58

Shared Pin Operation - Input/Output Pins

Pins 1 and 2 on the **ICS9148-58** serve as dual signal functions to the device. During initial power-up, they act as input pins. The logic level (voltage) that is present on these pins at this time is read and stored into a 4-bit internal data latch. At the end of Power-On reset, (see AC characteristics for timing values), the device changes the mode of operations for these pins to an output function. In this mode the pins produce the specified buffered clocks to external loads.

To program (load) the internal configuration register for these pins, a resistor is connected to either the VDD (logic 1) power supply or the GND (logic 0) voltage potential. A 10 Kilohm(10K) resistor is used to provide both the solid CMOS programming voltage needed during the power-up programming period and to provide an insignificant load on the output clock during the subsequent operating period.

Figs. 1 and 2 show the recommended means of implementing this function. In Fig. 1 either one of the resistors is loaded onto the board (selective stuffing) to configure the device's internal logic. Figs. 2a and b provide a single resistor loading option where either solder spot tabs or a physical jumper header may be used.

These figures illustrate the optimal PCB physical layout options. These configuration resistors are of such a large ohmic value that they do not effect the low impedance clock signals. The layouts have been optimized to provide as little impedance transition to the clock signal as possible, as it passes through the programming resistor pad(s).

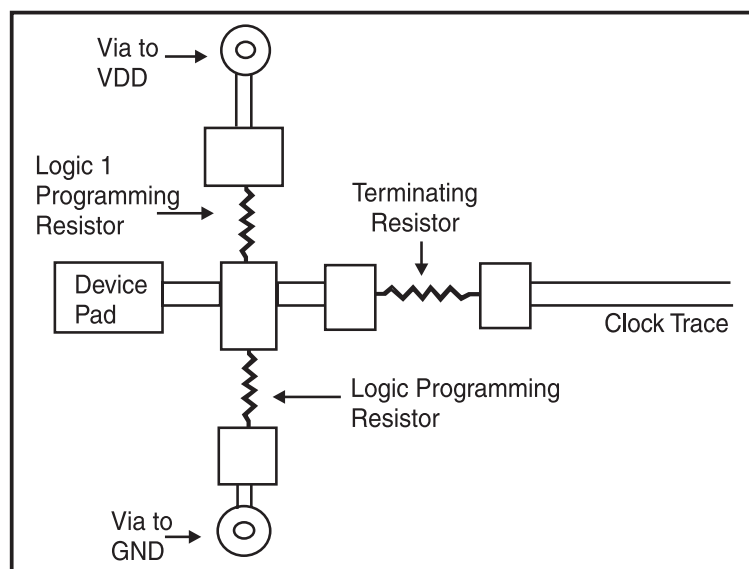

Fig. 1

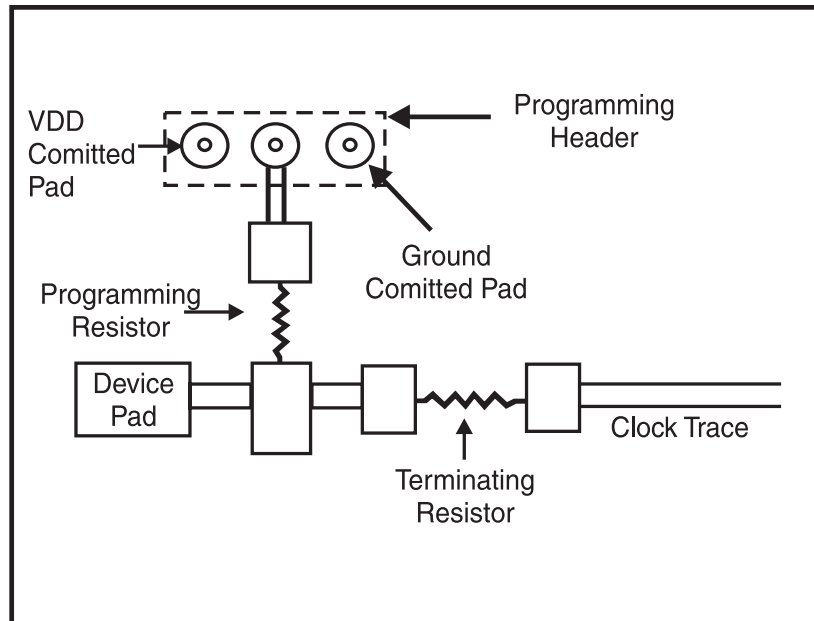

Fig. 2a

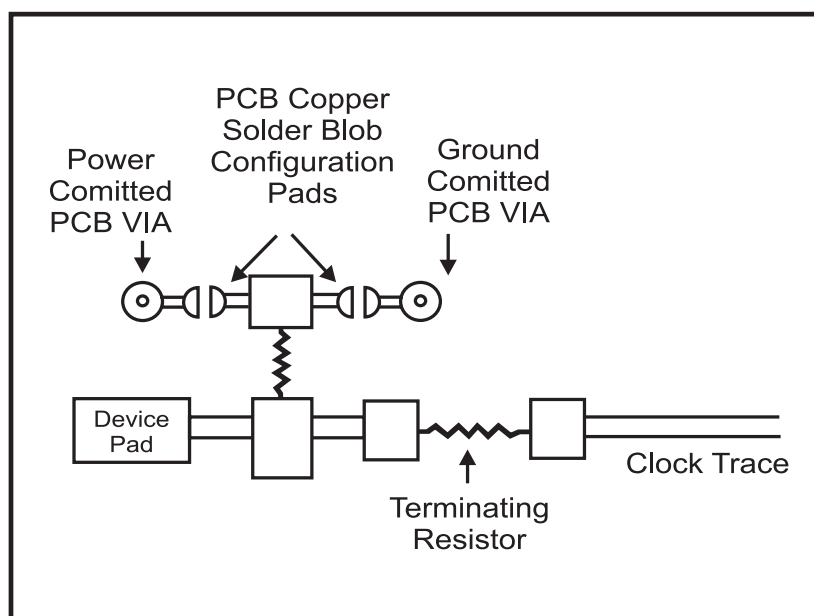

Fig. 2b



ICS9148-58

Absolute Maximum Ratings

Supply Voltage	7.0 V
Logic Inputs	GND-0.5 V to V _{DD} +0.5 V
Ambient Operating Temperature	0°C to +70°C
Storage Temperature	-65°C to +150°C

Stresses above those listed under *Absolute Maximum Ratings* may cause permanent damage to the device. These ratings are stress specifications only and functional operation of the device at these or any other conditions above those listed in the operational sections of the specifications is not implied. Exposure to absolute maximum rating conditions for extended periods may affect product reliability.

Electrical Characteristics - Input/Supply/Common Output Parameters

T_A = 0 - 70°C; Supply Voltage V_{DD} = V_{DDL} = 3.3 V +/-5% (unless otherwise stated)

PARAMETER	SYMBOL	CONDITIONS	MIN	TYP	MAX	UNITS
Input High Voltage	V _{IH}		2		V _{DD} +0.3	V
Input Low Voltage	V _{IL}		V _{SS} -0.3		0.8	V
Input High Current	I _{IH}	V _{IN} = V _{DD}		0.1	5	μA
Input Low Current	I _{IL1}	V _{IN} = 0 V; Inputs with no pull-up resistors	-5	2.0		μA
Input Low Current	I _{IL2}	V _{IN} = 0 V; Inputs with pull-up resistors	-200	-100		μA
Operating Supply Current	I _{DD3.3OP}	C _L = 0 pF; 66.8 MHz		100	160	mA
		C _L = 0 pF; 133 MHz		200	320	
Input frequency	F _i	V _{DD} = 3.3 V;	12	14.318	16	MHz
Input Capacitance ¹	C _{IN}	Logic Inputs			5	pF
	C _{INX}	X1 & X2 pins	27	36	45	pF
Transition Time ¹	T _{trans}	To 1st crossing of target Freq.			3	ms
Settling Time ¹	T _s	From 1st crossing to 1% target Freq.			2	ms
Clk Stabilization ¹	T _{STAB}	From V _{DD} = 3.3 V to 1% target Freq.			3	ms
Skew ¹	T _{CPU-PCI}	V _T = 1.5 V; CPU leads	1	3	4	ns
	T _{CPU-SDRAM}	V _T = 1.5 V; Window		100	250	ps

¹Guaranteed by design, not 100% tested in production.

Electrical Characteristics - Input/Supply/Common Output Parameters

T_A = 0 - 70°C; Supply Voltage V_{DD} = 3.3 V +/-5%, V_{DDL} = 2.5 V +/-5% (unless otherwise stated)

PARAMETER	SYMBOL	CONDITIONS	MIN	TYP	MAX	UNITS
Operating Supply Current	I _{DD2.5OP}	C _L = 0 pF; 66.8 MHz		10	20	mA
		C _L = 0 pF; 133 MHz		20	40	
Skew ¹	T _{CPU-PCI}	V _T = 1.5 V; CPU leads	1	3	4	ns
	T _{CPU-SDRAM}	V _T = 1.5 V; Window		100	250	ps

¹Guaranteed by design, not 100% tested in production.



Electrical Characteristics - CPU

T_A = 0 - 70°C; V_{DD} = V_{DDL} = 3.3 V +/-10%; C_L = 10 - 20 pF (unless otherwise stated)

PARAMETER	SYMBOL	CONDITIONS	MIN	TYP	MAX	UNITS
Output High Voltage	V _{OH2A}	I _{OH} = -28 mA	2.5	2.6		V
Output Low Voltage	V _{OL2A}	I _{OL} = 27 mA		0.35	0.4	V
Output High Current	I _{OH2A}	V _{OH} = 2.0 V		-29	-23	mA
Output Low Current	I _{OL2A}	V _{OL} = 0.8 V	33	37		mA
Rise Time	t _{r2A} ¹	V _{OL} = 0.4 V, V _{OH} = 2.4 V		1.75	2	ns
Fall Time	t _{f2A} ¹	V _{OH} = 2.4 V, V _{OL} = 0.4 V		1.1	2	ns
Duty Cycle	d _{t2A} ¹	V _T = 1.5 V	45	50	55	%
Skew	t _{sk2A} ¹	V _T = 1.5 V		50	250	ps
Jitter, One Sigma	t _{j1s2A} ¹	V _T = 1.5 V		65	150	ps
Jitter, Absolute	t _{jabs2A} ¹	V _T = 1.5 V	-250	165	250	ps

¹Guaranteed by design, not 100% tested in production.

Electrical Characteristics - CPU

T_A = 0 - 70°C; V_{DD} = 3.3 V +/-5%, V_{DDL} = 2.5 V +/-5%; C_L = 10 - 20 pF (unless otherwise stated)

PARAMETER	SYMBOL	CONDITIONS	MIN	TYP	MAX	UNITS
Output High Voltage	VOH2B	I _{OH} = -8 mA	2	2.2		V
Output Low Voltage	VOL2B	I _{OL} = 12 mA		0.3	0.4	V
Output High Current	IOH2B	V _{OH} = 1.7 V		-20	-16	mA
Output Low Current	IOL2B	V _{OL} = 0.7 V	19	26		mA
Rise Time	tr2B ¹	V _{OL} = 0.4 V, V _{OH} = 2.0 V		1.5	1.8	ns
Fall Time	tf2B ¹	V _{OH} = 2.0 V, V _{OL} = 0.4 V		1.6	1.8	ns
Duty Cycle	dt2B ¹	V _T = 1.25 V	40	47	55	%
Skew	tsk2B ¹	V _T = 1.25 V		60	250	ps
Jitter, Single Edge Displacement ²	tjsed2B ¹	V _T = 1.25 V		200	250	ps
Jitter, One Sigma	tj1s2B ¹	V _T = 1.25 V		65	150	ps
Jitter, Absolute	tjabs2B ¹	V _T = 1.25 V	-300	160	300	ps

¹Guaranteed by design, not 100% tested in production.

² Edge displacement of a period relative to a 10-clock-cycle rolling average period.



ICS9148-58

Electrical Characteristics - PCI

$T_A = 0 - 70^\circ\text{C}$; $V_{DD} = V_{DDL} = 3.3 \text{ V} \pm 10\%$; $C_L = 30 \text{ pF}$ (unless otherwise stated)

PARAMETER	SYMBOL	CONDITIONS	MIN	TYP	MAX	UNITS
Output High Voltage	V_{OH1}	$I_{OH} = -28 \text{ mA}$	2.4	3		V
Output Low Voltage	V_{OL1}	$I_{OL} = 23 \text{ mA}$		0.2	0.4	V
Output High Current	I_{OH1}	$V_{OH} = 2.0 \text{ V}$		-60	-40	mA
Output Low Current	I_{OL1}	$V_{OL} = 0.8 \text{ V}$	41	50		mA
Rise Time	t_{r1}^1	$V_{OL} = 0.4 \text{ V}, V_{OH} = 2.4 \text{ V}$		1.8	2	ns
Fall Time	t_{f1}^1	$V_{OH} = 2.4 \text{ V}, V_{OL} = 0.4 \text{ V}$		1.6	2	ns
Duty Cycle	d_{t1}^1	$V_T = 1.5 \text{ V}$	45	51	55	%
Skew	t_{sk1}^1	$V_T = 1.5 \text{ V}$		130	250	ps
Jitter, One Sigma ¹	t_{j1s1a}	$V_T = 1.5 \text{ V}$, synchronous		40	150	ps
	t_{j1s1b}	$V_T = 1.5 \text{ V}$, asynchronous		200	250	ps
Jitter, Absolute ¹	t_{abs1a}	$V_T = 1.5 \text{ V}$, synchronous	-250	135	250	ps
	t_{abs1b}	$V_T = 1.5 \text{ V}$, asynchronous	-650	500	650	ps

¹Guaranteed by design, not 100% tested in production.

Electrical Characteristics - SDRAM

$T_A = 0 - 70^\circ\text{C}$; $V_{DD} = V_{DDL} = 3.3 \text{ V} \pm 5\%$; $C_L = 30 \text{ pF}$

PARAMETER	SYMBOL	CONDITIONS	MIN	TYP	MAX	UNITS
Output High Voltage	V_{OH1}	$I_{OH} = -28 \text{ mA}$	2.4	3		V
Output Low Voltage	V_{OL1}	$I_{OL} = 23 \text{ mA}$		0.2	0.4	V
Output High Current	I_{OH1}	$V_{OH} = 2.0 \text{ V}$		-60	-40	mA
Output Low Current	I_{OL1}	$V_{OL} = 0.8 \text{ V}$	41	50		mA
Rise Time ¹	T_{r1}	$V_{OL} = 0.4 \text{ V}, V_{OH} = 2.4 \text{ V}$		1.75	2	ns
Fall Time ¹	T_{f1}	$V_{OH} = 2.4 \text{ V}, V_{OL} = 0.4 \text{ V}$		1.5	2	ns
Duty Cycle ¹	D_{t1}	$V_T = 1.5 \text{ V}$	45	50	55	%
Skew ¹	T_{sk1}	$V_T = 1.5 \text{ V}$		200	500	ps
Jitter, One Sigma ¹	T_{j1s1}	$V_T = 1.5 \text{ V}$		50	150	ps
Jitter, Absolute ¹	T_{jabs1}	$V_T = 1.5 \text{ V}$ (with synchronous PCI)	-250		+250	ps
Jitter, Absolute ¹	T_{jabs1}	$V_T = 1.5 \text{ V}$ (with asynchronous PCI)	-400		400	ps

¹Guaranteed by design, not 100% tested in production.



Electrical Characteristics - AGP

T_A = 0 - 70C; V_{DD} = V_{DDL} = 3.3 V +/-10%; C_L = 30 pF (unless otherwise stated)

PARAMETER	SYMBOL	CONDITIONS	MIN	TYP	MAX	UNITS
Output High Voltage	V _{OH1}	I _{OH} = -28 mA	2.4	3		V
Output Low Voltage	V _{OL1}	I _{OL} = 23 mA		0.2	0.4	V
Output High Current	I _{OH1}	V _{OH} = 2.0 V		-60	-40	mA
Output Low Current	I _{OL1}	V _{OL} = 0.8 V	41	50		mA
Rise Time	t _{r1} ¹	V _{OL} = 0.4 V, V _{OH} = 2.4 V		1.1	2	ns
Fall Time	t _{f1} ¹	V _{OH} = 2.4 V, V _{OL} = 0.4 V		1	2	ns
Duty Cycle	d _{t1} ¹	V _T = 1.4 V	45	49	55	%
Skew	t _{sk1} ¹	V _T = 1.5 V		130	250	ps
Jitter, One Sigma ¹	t _{j1s1}	V _T = 1.5 V		2	3	%
Jitter, Absolute ¹	t _{abs1a}	V _T = 1.5 V, synchronous	-5	2.5	5	%
	t _{abs1b}	V _T = 1.5 V, asynchronous	-6	4.5	6	%

¹Guaranteed by design, not 100% tested in production.

Electrical Characteristics - 24MHz, 48MHz, REF0

T_A = 0 - 70C; V_{DD} = V_{DDL} = 3.3 V +/-10%; C_L = 10 -20 pF (unless otherwise stated)

PARAMETER	SYMBOL	CONDITIONS	MIN	TYP	MAX	UNITS
Output High Voltage	V _{OH5}	I _{OH} = -16 mA	2.4	2.6		V
Output Low Voltage	V _{OL5}	I _{OL} = 9 mA		0.3	0.4	V
Output High Current	I _{OH5}	V _{OH} = 2.0 V		-32	-22	mA
Output Low Current	I _{OL5}	V _{OL} = 0.8 V	16	25		mA
Rise Time	t _{r5} ¹	V _{OL} = 0.4 V, V _{OH} = 2.4 V		2	4	ns
Fall Time	t _{f5} ¹	V _{OH} = 2.4 V, V _{OL} = 0.4 V		1.9	4	ns
Duty Cycle	d _{t5} ¹	V _T = 1.5 V	45	54	57	%
Jitter, One Sigma	t _{j1s5} ¹	V _T = 1.5 V		1	3	%
Jitter, Absolute	t _{jabs5} ¹	V _T = 1.5 V	-5	-	5	%

¹Guaranteed by design, not 100% tested in production.



ICS9148-58

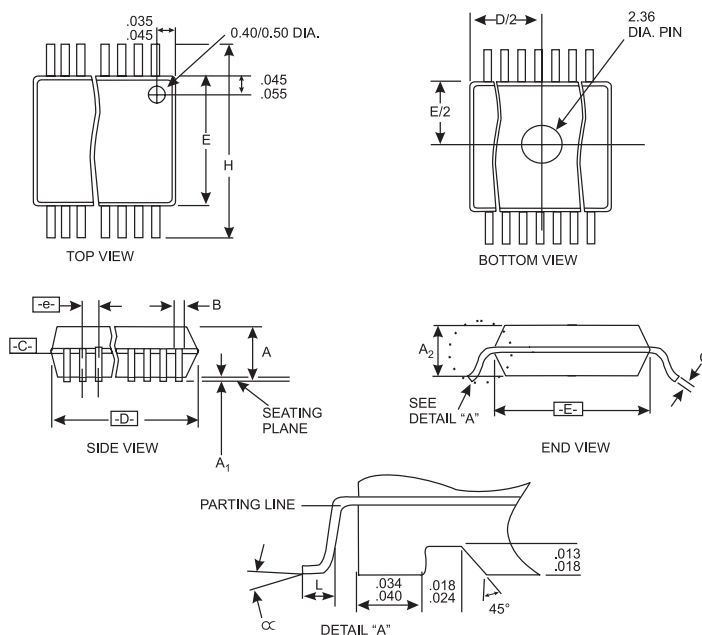

SSOP Package

SYMBOL	COMMON DIMENSIONS			VARIATIONS	D			N
	MIN.	NOM.	MAX.		MIN.	NOM.	MAX.	
A	.095	.101	.110	AC	.620	.625	.630	48
A1	.008	.012	.016					
A2	.088	.090	.092					
B	.008	.010	.0135					
C	.005	-	.010					
D	See Variations							
E	.292	.296	.299					
e	0.025 BSC							
H	.400	.406	.410					
h	.010	.013	.016					
L	.024	.032	.040					
N	See Variations							
∞	0°	5°	8°					
X	.085	.093	.100					

Ordering Information

ICS9148F-58

Example:

ICS XXXX F - PPP

