

IR CONFIDENTIAL

DOCUMENT AND THE DATA DISCLOSED HEREWITH IS NOT TO BE REPRODUCED, DISCLOSED, COPIED OR IN PART REPRODUCED WITHOUT PERMISSION OF VICOR CORP.

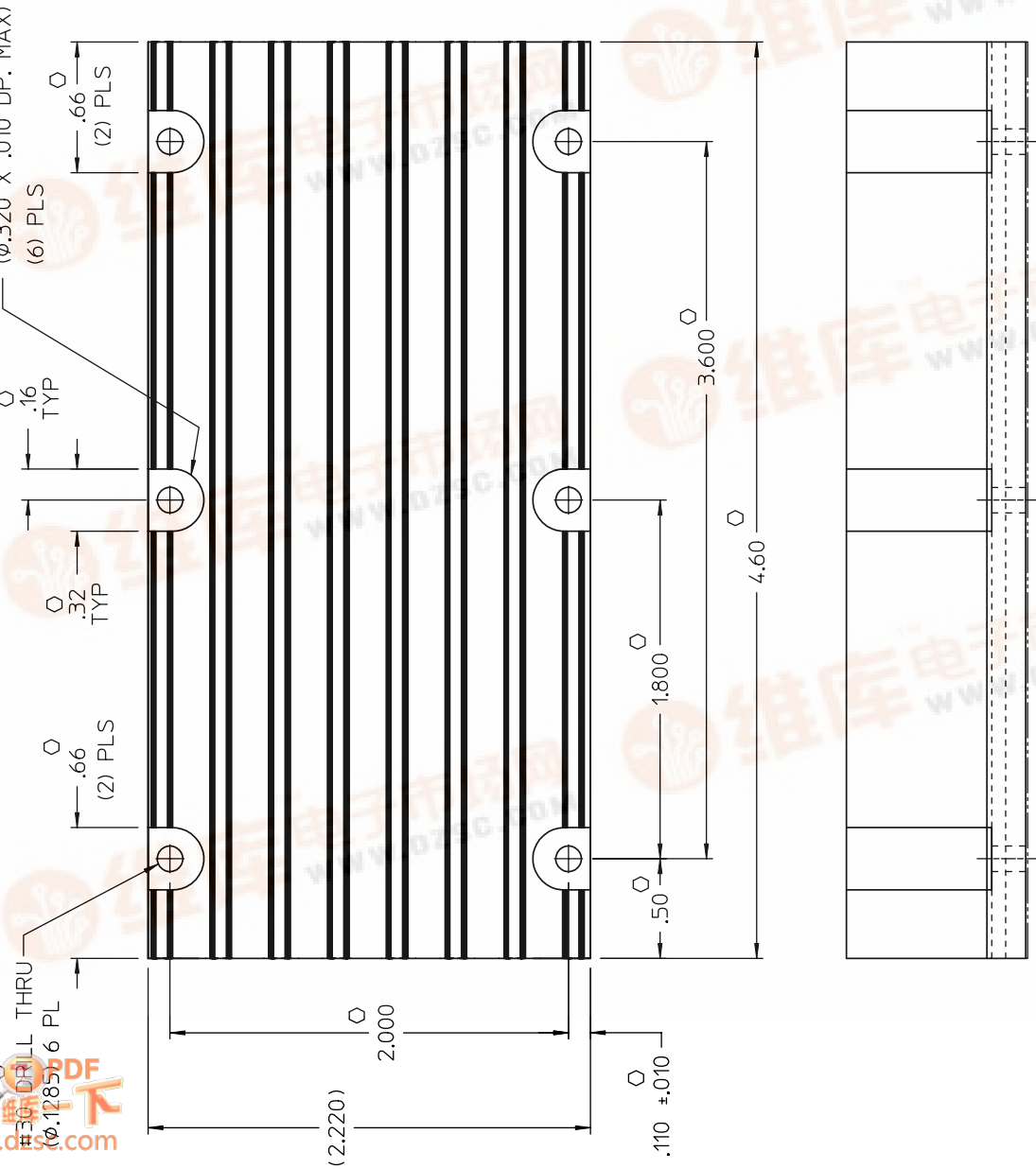

查询17443-B供应商

捷多邦, 专业PCB打样工厂, 24小时加急出货

REV.	DESCRIPTION	DATE	APPROVED
#6	.190 WAS .170; REVISED NOTES	9/23/97	SWN
#7	TWO PLACE DIMS WERE THREE PLACE	10/10/97	SWN
#8	(2.220) WAS (2.200); ADDED .010 TOL	10/10/97	SWN
#9	REMOVED P/N STAMPING NOTE 4	8/26/98	SWN
#A	ADDED SPOTFACES	1/6/99	SWN
#B	ADDED NOTE 4, CRITICAL CHA. *O*	10/7/99	SWN

DRAWN BY: RENAUD		DATE: 4/97
UNLESS OTHERWISE SPECIFIED, DIMENSIONS ARE IN INCHES. TOLERANCES ARE: FRACTIONS DECIMALS ANGLES		
PRACTICES: XXS=+.01 .XX=+.005		
THIRD ANGLE PROJECTION		
SIZE: C	FSC# NO: 67131	DWG NO: 17443
REV: #B		REV: #B
SCALE: 2=1	SHEET 1 OF 1	

VICOR

HTSNK "A" LONG .9H
LOW FLOW, THRU HOLE

- NOTES
1. MAKE FROM VICOR EXTRUSION P/N 15948.
 2. REMOVE ALL BURRS AND SHARP EDGES.
 3. FINISH: CLEAR CHROMATE.
 4. *O* DENOTES CRITICAL CHARACTERISTICS FOR LOT INSPECTION.