

4-BIT SINGLE-CHIP MICROCONTROLLER
FOR SMALL GENERAL-PURPOSE INFRARED REMOTE CONTROL TRANSMITTER

DESCRIPTION

μ PD17215, 17216, 17217, 17218 (hereafter called μ PD17215 subseries) are 4-bit single-chip microcontrollers for small general-purpose infrared remote control transmitters.

It employs a 17K architecture of general-purpose register type devices for the CPU, and can directly execute operations between memories instead of the conventional method of executing operations through the accumulator. Moreover, all the instructions are 16-bit 1-word instructions which can be programmed efficiently.

In addition, a one-time PROM model, μ PD17P218, to which data can be written only once, is also available. It is convenient either for evaluating the μ PD17215 subseries programs or small-scale production of application systems.

Detailed functions are described in the following manual. Be sure to read this manual when designing your system.

μ PD172 \times Subseries User's Manual: IEU-1317

FEATURES

- Infrared remote controller carrier generator circuit (REM output)
- 17K architecture: General-purpose register system
- Program memory (ROM), Data memory (RAM)

	μ PD17215	μ PD17216	μ PD17217	μ PD17218
Program memory (ROM)	4 K bytes (2048 \times 16)	8 K bytes (4096 \times 16)	12 K bytes (6144 \times 16)	16 K bytes (8192 \times 16)
Data memory (RAM)	111 \times 4 bits		223 \times 4 bits	

- 8-bit timer : 1 channel
- Basic internal timer / Watchdog timer: 1 channel ($\overline{\text{WDOUT}}$ output)
- Instruction execution time (can be changed in two steps)
 - at fx 4 MHz : 4 μ s (high-speed mode)/8 μ s (ordinary mode)
 - at fx 8 MHz : 2 μ s (high-speed mode)/4 μ s (ordinary mode)
- External interrupt pin (INT) : 1
- I/O pins : 20
- Supply voltage : $V_{\text{DD}} = 2.2$ to 5.5 V (at fx = 4 MHz (high-speed mode))
 $V_{\text{DD}} = 2.0$ to 5.5 V (at fx = 4 MHz (ordinary mode))
- Low-voltage detector circuit (mask option)

Unless otherwise specified, the μ PD17215 is treated as the representative model throughout this document.

The information in this document is subject to change without notice.

APPLICATION

Preset remote controllers, toys, portable systems, etc.

ORDERING INFORMATION

Part Number	Package
μ PD17215CT-xxx	28-pin plastic shrink DIP (400 mil)
μ PD17215GT-xxx	28-pin plastic SOP (375 mil)
μ PD17216CT-xxx	28-pin plastic shrink DIP (400 mil)
μ PD17216GT-xxx	28-pin plastic SOP (375 mil)
μ PD17217CT-xxx	28-pin plastic shrink DIP (400 mil)
μ PD17217GT-xxx	28-pin plastic SOP (375 mil)
μ PD17218CT-xxx	28-pin plastic shrink DIP (400 mil)
μ PD17218GT-xxx	28-pin plastic SOP (375 mil)

Remark: xxx is ROM code number.

PIN CONFIGURATION (TOP VIEW)

- 28-pin plastic SOP (375 mil)
μPD17215GT-xxx, 17216GT-xxx, 17217GT-xxx, 17218GT-xxx
- 28-pin plastic shrink DIP (400 mil)
μPD17215CT-xxx, 17216CT-xxx, 17217CT-xxx, 17218CT-xxx

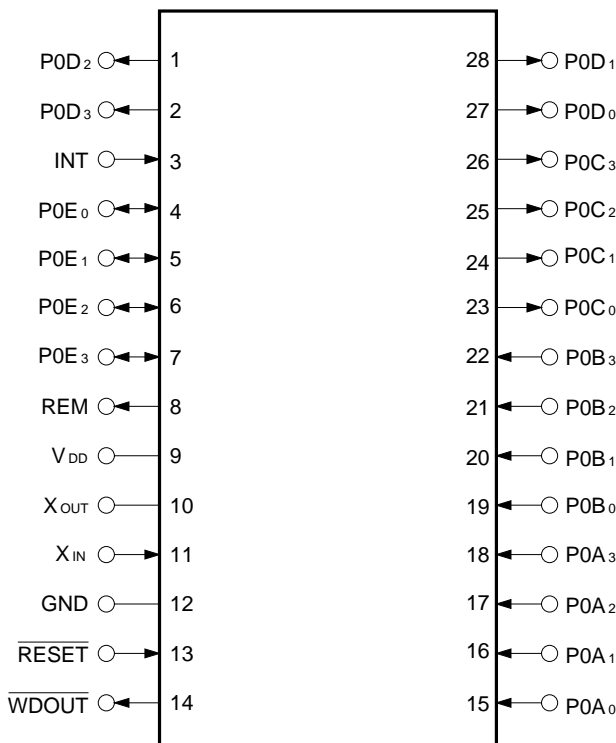

- GND : Ground
- INT : External interrupt request signal input
- P0A0-P0A3 : Input port (CMOS input)
- P0B0-P0B3 : Input port (CMOS input)
- P0C0-P0C3 : Output port (N-ch open-drain output)
- P0D0-P0D3 : Output port (N-ch open-drain output)
- P0E0-P0E3 : I/O port (CMOS push-pull output)
- REM : Remote controller output (CMOS push-pull output)
- RESET : Reset input
- VDD : Power supply
- WDOUT : Hang-up/low voltage detection output (N-ch open-drain output)
- XIN, XOUT : Oscillator connection

BLOCK DIAGRAM

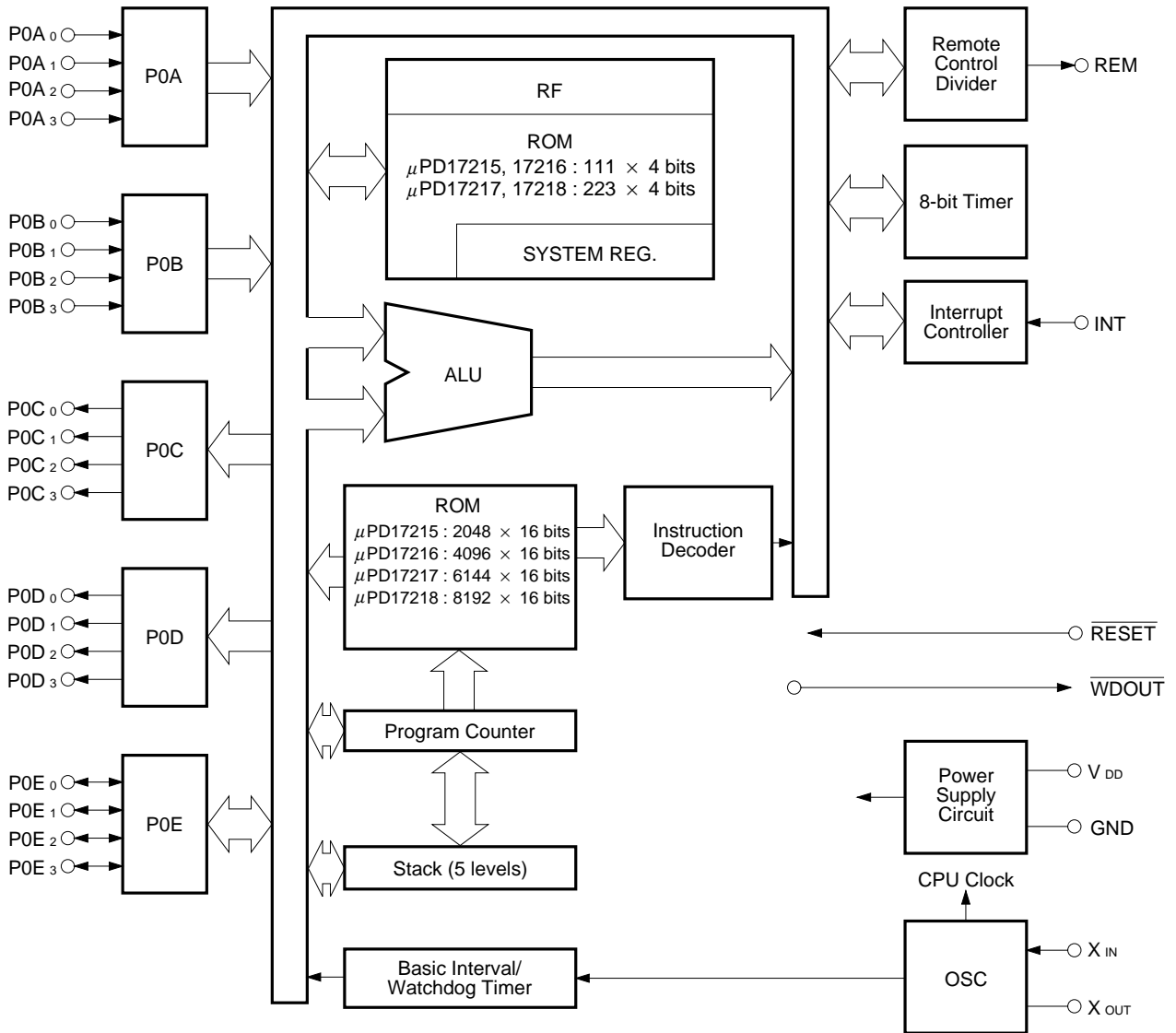

CONTENTS

1. PIN FUNCTIONS	7
1.1 Pin Function List	7
1.2 Input/Output Circuits	8
1.3 Processing of Unused Pins.....	9
1.4 Notes on Using INT and RESET Pins	9
2. MEMORY SPACE.....	10
2.1 Program Counter (PC)	10
2.2 Program Memory (ROM)	10
2.3 Stack	12
2.4 Data Memory (RAM)	14
2.5 Register File (RF)	21
3. PORTS	24
3.1 Port 0A (P0A0-P0A3)	24
3.2 Port 0B (P0B0-P0B3)	24
3.3 Port 0C (P0C0-P0C3)	24
3.4 Port 0D (P0D0-P0D3)	24
3.5 Port 0E (P0E0-P0E3)	24
3.6 INT Pin	25
3.7 Switching Bit I/O	26
3.8 Specifying Pull-up Resistor Connection	27
4. CLOCK GENERATOR CIRCUIT	28
4.1 Instruction Execution Time (CPU Clock) Selection	28
5. 8-BIT TIMER AND REMOTE CONTROLLER CARRIER GENERATOR CIRCUIT	29
5.1 Configuration of 8-bit Timer (with modulo function).....	29
5.2 Function of 8-bit Timer (with modulo function)	31
5.3 Carrier Generator Circuit for Remote Controller	32
6. BASIC INTERVAL TIMER/WATCHDOG TIMER	36
6.1 Source Clock for Basic Interval Timer	36
6.2 Controlling Basic Interval Timer	36
6.3 Operation Timing for Watchdog Timer	38
7. INTERRUPT FUNCTIONS	39
7.1 Interrupt Sources	39
7.2 Hardware of Interrupt Control Circuit	40
7.3 Interrupt Sequence	44

8. STANDBY FUNCTIONS 46

8.1 HALT Mode 46

8.2 HALT Instruction Execution Conditions 47

8.3 STOP Mode 47

8.4 STOP Instruction Execution Conditions 49

8.5 Releasing Standby Mode 49

9. RESET 50

9.1 Reset by Reset Signal Input 50

9.2 Reset by Watchdog Timer (Connect $\overline{\text{RESET}}$ and $\overline{\text{WDOUT}}$ pins) 50

9.3 Reset by Stack Pointer (Connect $\overline{\text{RESET}}$ and $\overline{\text{WDOUT}}$ pins) 51

10. LOW-VOLTAGE DETECTOR CIRCUIT (CONNECT $\overline{\text{RESET}}$ AND $\overline{\text{WDOUT}}$ PINS) 51

11. ASSEMBLER RESERVED WORDS 52

11.1 Mask Option Directives 52

11.2 Reserved Symbols 53

12. INSTRUCTION SET 58

12.1 Instruction Set Outline 58

12.2 Legend 59

12.3 List of Instruction Sets 60

12.4 Assembler (AS17K) Built-In Macro Instruction 62

13. ELECTRICAL SPECIFICATIONS 63

14. CHARACTERISTIC WAVEFORMS (REFERENCE VALUE) 70

15. APPLICATION CIRCUIT EXAMPLE 73

16. PACKAGE DRAWINGS 74

17. RECOMMENDED SOLDERING CONDITIONS 76

APPENDIX A. DIFFERENCES AMONG μPD17215, 17216, 17217, 17218 AND μPD17P218 77

APPENDIX B. FUNCTIONAL COMPARISON OF μPD17215 SUBSERIES RELATED PRODUCTS 78

APPENDIX C. DEVELOPMENT TOOLS 79

1. PIN FUNCTIONS

1.1 Pin Function List

No.	Symbol	Function	Output Form	On Reset
15 16 17 18	P0A ₀ P0A ₁ P0A ₂ P0A ₃	4-bit CMOS input port with pull-up resistor. Can be used for key return input of key matrix. When at least one of these pins goes low, standby function is released.	-	Input
19 20 21 22	P0B ₀ P0B ₁ P0B ₂ P0B ₃	4-bit CMOS input port with pull-up resistor. Can be used for key return input of key matrix. When at least one of these pins goes low, standby function is released.	-	Input
23 24 25 26	P0C ₀ P0C ₁ P0C ₂ P0C ₃	4-bit N-ch open-drain output port. Can be used for key source output of key matrix.	N-ch Open- drain	Low- level output
27 28 1 2	P0D ₀ P0D ₁ P0D ₂ P0D ₃	4-bit N-ch open-drain output port. Can be used for key source output of key matrix.	N-ch Open- drain	Low- level output
4 5 6 7	P0E ₀ P0E ₁ P0E ₂ P0E ₃	4-bit input/output port. Can be set in inputset in input or output mode in 1-bit units. In output mode, this port functions as a highcurrent CMOS output port. In input mode, function as CMOS input and can bespecified to connect pull-up resistor by program.	CMOS push- pull	Input
8	REM	Outputs transfer signal for infrared remotecontroller. Active-high output.	CMOS push- pull	Low-level output
13	$\overline{\text{RESET}}$	System reset input. CPU can be reset when low-level signal is input to this pin. While low-level signal is input, oscillator circuit is stopped. Can be connected to pull-upresistor by mask option.	-	Input
9	V _{DD}	Power supply	-	-
12	GND	Ground	-	-
3	INT	External interrupt request signal input	-	Input
14	$\overline{\text{WDOU}}$	Output detecting hang-up and drop in supply voltage.This pin outputs at low level either when an overflow occurs in the watchdog timer, when an overflow/underflow occurs in the stack, or when the supply voltage drops below a specified level (mask option). Connect this pin to the $\overline{\text{RESET}}$ pin.	N-ch Open- drain	High- impedance Low-level output at low voltage detection
11 10	X _{IN} X _{OUT}	Connects ceramic oscillator for system clock oscillation	-	(Oscillation stops)

★ 1.2 Input/Output Circuits

The equivalent input/output circuit for each μ PD17215 pin is shown below.

(1) P0A, P0B

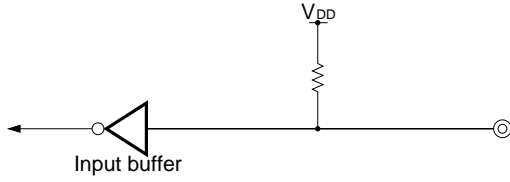

(2) P0C, P0D

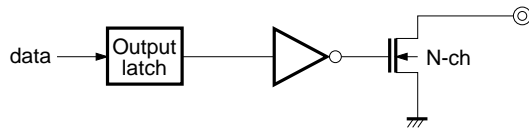

(3) P0E

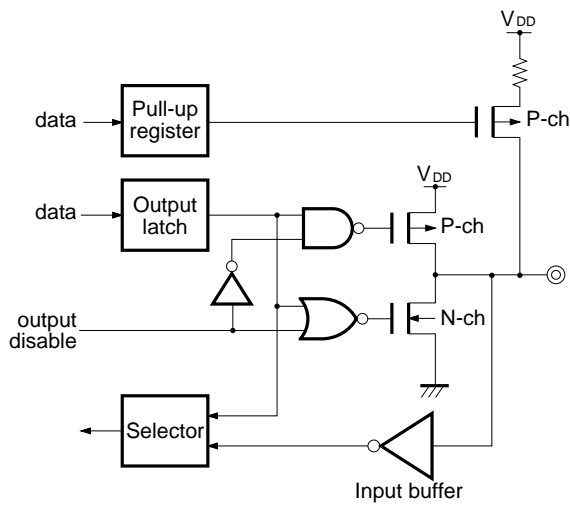

(4) $\overline{\text{RESET}}$

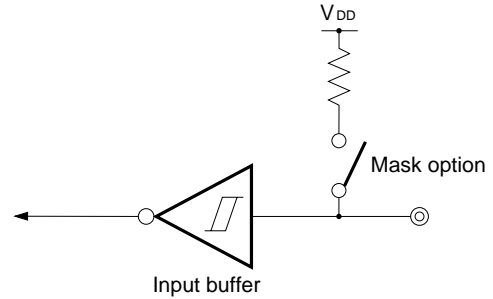

Schmitt trigger input with hysteresis characteristics

(5) INT

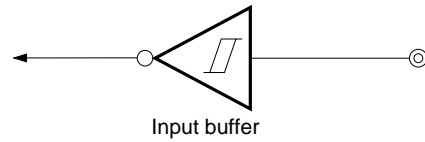

Schmitt trigger input with hysteresis characteristics

(6) REM

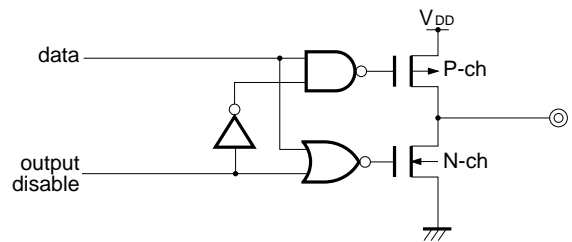

(7) $\overline{\text{WDOUT}}$

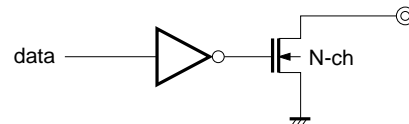

1.3 Processing of Unused Pins

Process the unused pins as follows:

Table 1-1 Processing of Unused Pins

Pin	Recommended Connection
P0A ₀ -P0A ₃	Connect to V _{DD}
P0B ₀ -P0B ₃	Connect to V _{DD}
P0C ₀ -P0C ₃	Connect to GND
P0D ₀ -P0D ₃	Connect to GND
P0E ₀ -P0E ₃	Input : Connect to V _{DD} or GND Output : Open
REM	Open
INT	Connect to GND
WDO _{UT}	Connect to GND

1.4 Notes on Using INT and RESET Pins

In addition to the functions shown in 1.1 PIN FUNCTIONS, the INT and RESET pins also have a function to set a test mode (for IC testing) in which the internal operations of the μPD17215 are tested.

When a voltage higher than V_{DD} is applied to either of these pins, the test mode is set. This means that, even during ordinary operation, the μPD17215 may be set in the test mode if a noise exceeding V_{DD} is applied.

For example, if the wiring length of the INT or RESET pin is too long, noise superimposed on the wiring line of the pin main cause the above problem.

Therefore, keep the wiring length of these pins as short as possible to suppress the noise; otherwise, take noise preventive measures as shown below by using external components.

- Connect diode with low V_F between V_{DD} and INT/RESET pin
- Connect capacitor between V_{DD} and INT/RESET pin

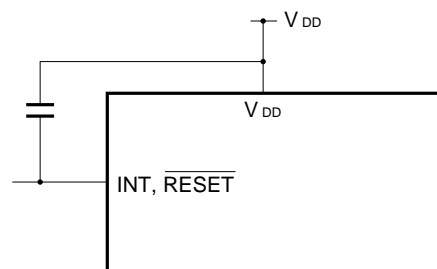
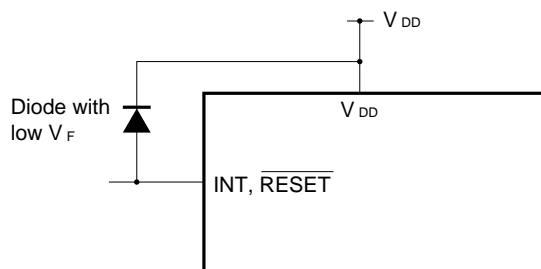

If the test mode is set by the INT pin, low level is output from the WDO_{UT} pin. In this case, connect the WDO_{UT} and RESET pin.

2. MEMORY SPACE

2.1 Program Counter (PC)

The program counter (PC) specifies an address of the program memory (ROM). The program counter is a 11/12/13-bit binary counter as shown in Fig. 2-1. Its contents are initialized to address 0000H at reset.

Fig. 2-1 Configuration of Program Counter

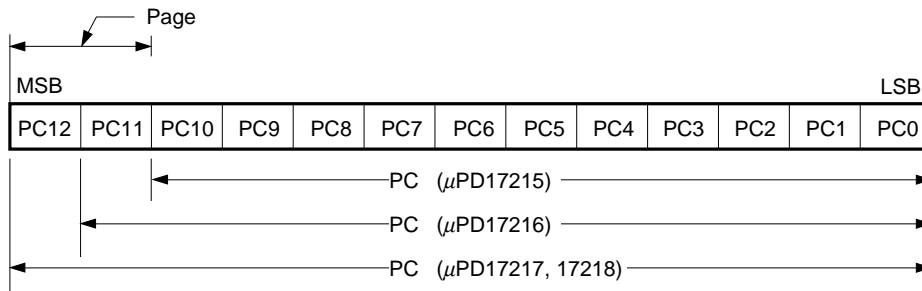

2.2 Program Memory (ROM)

The configuration of the program memory is as follows:

Part Number	Capacity	Address
μPD17215	2048 x 16 bits	0000H-07FFH
μPD17216	4096 x 16 bits	0000H-0FFFH
μPD17217	6144 x 16 bits	0000H-17FFH
μPD17218	8192 x 16 bits	0000H-1FFFH

The program memory stores a program, interrupt vector table, and fixed data table.

The program memory is addressed by the program counter.

Fig. 2-2 shows the program memory map. The entire range of the program memory can be addressed by the BD addr, BR @AR, CALL @AR, MOV T DBF, and @AR instructions. Note, however, that the subroutine entry addresses that can be specified by the CALL addr instruction are from 0000H to 07FFH.

Fig. 2-2 Program Memory Map

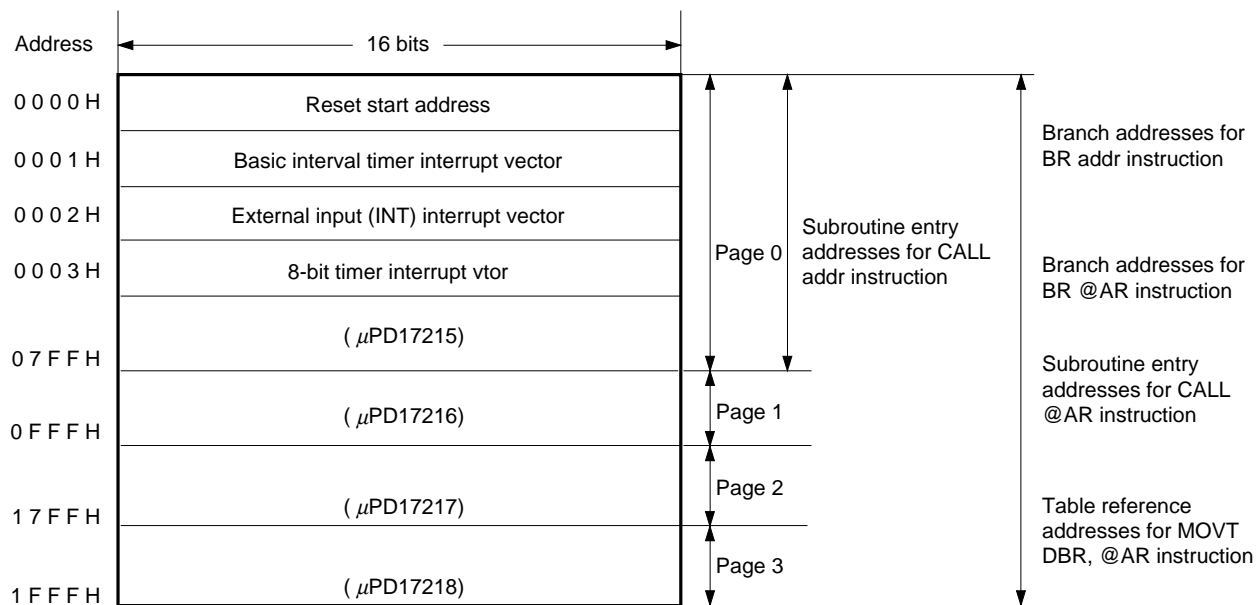

2.3 Stack

A stack is a register to save a program return address and the contents of system registers (to be described later) when a subroutine is called or when an interrupt is accepted.

2.3.1 Stack configuration

Fig. 2-3 shows the stack configuration.

A stack consists of a stack pointer (a 4-bit binary counter, the upper 1-bit fixed to 0), five 11-bit (μPD17215)/12-bit (μPD17216)/13-bit (μPD17217, 17218) address stack registers, and three 5-bit (μPD17215, 17216)/6-bit (μPD17217, 17218) interrupt stack registers.

Fig. 2-3 Stack Configuration

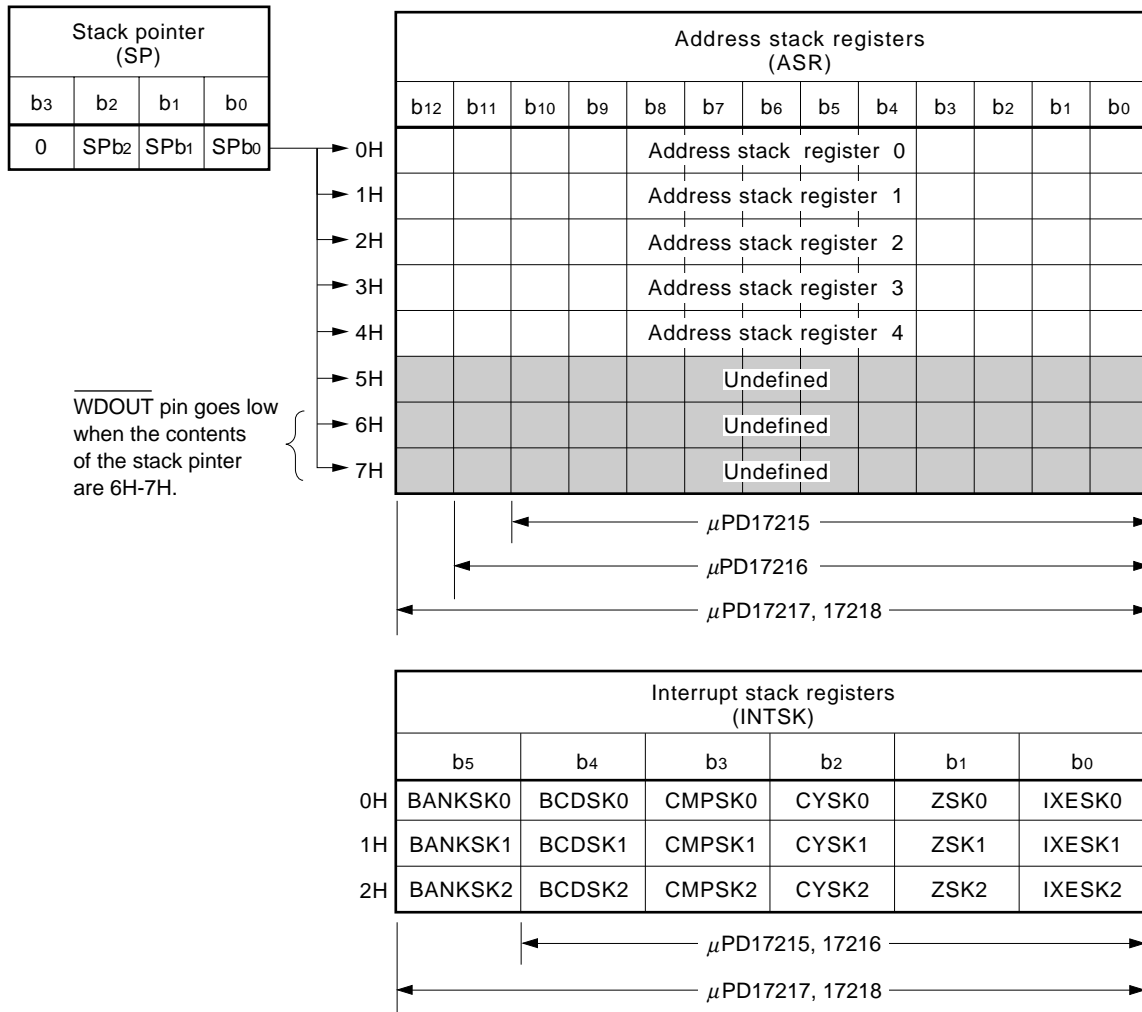

2.3.2 Function of stack

The address stack register stores a return address when the subroutine call instruction or table reference instruction (first instruction cycle) is executed or when an interrupt is accepted. It also stores the contents of the address registers (ARs) when a stack manipulation instruction (PUSH AR) is executed.

The WDOUT pin goes low if a subroutine call or interrupt exceeding 5 levels is executed.

The interrupt stack register (INTSK) saves the contents of the bank register (BANK) and program status word (PSWORD) when an interrupt is accepted. The saved contents are restored when an interrupt return (RETI) instruction is executed.

INTSK saves data each time an interrupt is accepted, but **the data stored first is lost if more than 3 levels of interrupts occur.**

2.3.3 Stack Pointer (SP) and Interrupt Stack Pointer

Table 2-1 shows the operations of the stack pointer (SP).

The stack pointer can take eight values, 0H-07. Because there are only five stack registers available, however, **the WDOUT pin goes low if the value of SP is 6 or greater.**

Table 2-1 Operations of Stack Pointer

Instruction	Value of Stack Pointer (SP)	Counter of Interrupt Stack Register
CALL addr CALL @AR MOVT DBF, @AR (1st Instruction Cycle) PUSH AR	-1	0
When Interrupt Is Accepted	-1	-1
RET RETSK MOVT DBF, @AR (2nd Instruction Cycle) POP AR	+1	0
RETI	+1	+1

2.4 Data Memory (RAM)

Data memory (random access memory) stores data for operations and control. It can be read-/write-accessed by instructions.

2.4.1 Memory configuration

Figure 2-4 shows the configuration of the data memory (RAM).

The data memory consists of two “banks”: BANK0 and BANK1.

In each bank, every 4 bits of data is assigned an address. The higher 3 bits of the address indicate a “row address” and the lower 4 bits of the address indicate a “column address”. For example, a data memory location indicated by row address 1H and column address 0AH is termed a data memory location at address 1AH. Each address stores data of 4 bits (= a “nibble”).

In addition, the data memory is divided into following six functional blocks:

(1) System register (SYSREG)

A system register (SYSREG) is resident on addresses 74H to 7FH (12 nibbles long) of each bank. In other nibbles, each bank has a system register at its addresses 74H to 7FH.

(2) Data buffer (DBF)

A data buffer is resident on addresses 0CH to 0FH (4 nibbles long) of bank 0 of data memory.
The reset value is 0320H.

(3) General register (GR)

A general register is resident on any row (16 nibbles long) of any bank of data memory.
The row address of the general register is pointed by the general pointer (RP) in the system register (SYSREG).

(4) Port register

A port data register is resident on addresses 6FH, and 70H to 73H (5 nibbles) of BANK0 of data memory.
No data can be written to the addresses 70H to 73H of BANK1 (the values of addresses 70H to 73H of BANK0 are read in this case).

μ PD17215 and 17216 are not provided with BANK1.

(5) General-purpose data memory

The general-purpose data memory area is an area of the data memory excluding the system register area, and the port register area. This memory area has a total of 223 nibbles (111 nibbles in BANK0 and 112 nibbles in BANK1).

μPD17215 and 17216 are not provided with BANK1.

Fig. 2-4 Configuration of Data Memory

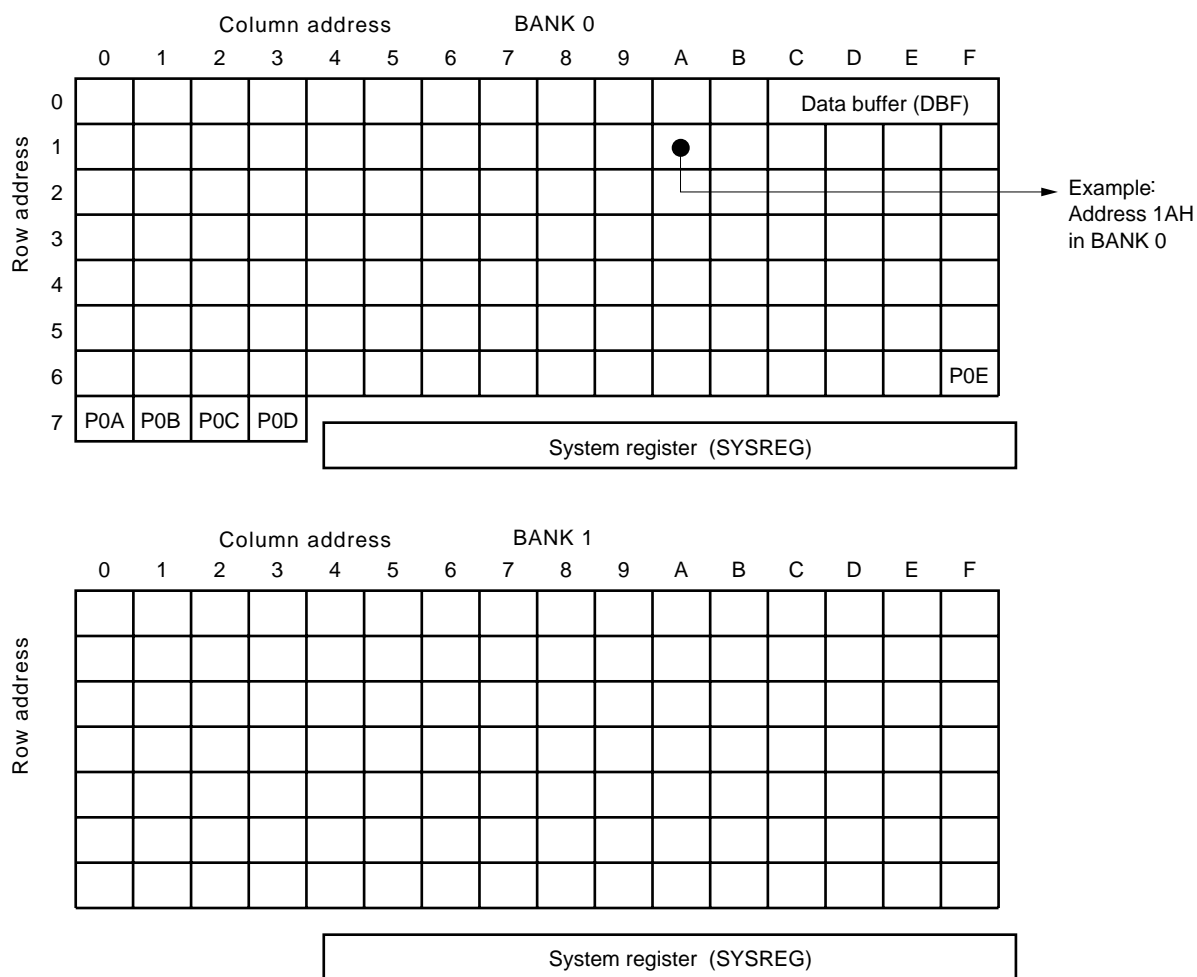

Caution: No data can be written to the addresses 70H to 73H of BANK1 (the value of P0A to P0D are read in this case).

2.4.2 System registers (SYSREG)

The system registers are registers that are directly related to control of the CPU. These registers are mapped to addresses 74H-7FH on the data memory and can be referenced regardless of bank specification.

The system registers include the following registers:

- Address registers (AR0-AR3)*
- Window register (WR)
- Bank register (BANK)*
- Memory pointer enable flag (MPE)
- Memory pointers (MPH, MPL)
- Index registers (IXH, IXM, IXL)
- General register pointers (RPH, RPL)
- Program status word (PSWORD)

*: The address register (AR3) and the bank register (BANK) are fixed to 0 in the μPD17215 and 17216.

Fig. 2-5 Configuration of System Register

Address	74H	75H	76H	77H	78H	79H	7AH	7BH	7CH	7DH	7EH	7FH
Name	Address register (AR)				Window register (WR)	Bank register (BANK)	Index register (IX)			General register pointer (RP)		Program status word (PSWORD)
Symbol	AR 3	AR 2	AR 1	AR 0	WR	BANK	IXH	IXM	IXL	RPH	RPL	PSW
							MPH	MPL				
Bit	b3 b2 b1 b0	b3 b2 b1 b0	b3 b2 b1 b0	b3 b2 b1 b0	b3 b2 b1 b0	b3 b2 b1 b0	b3 b2 b1 b0	b3 b2 b1 b0	b3 b2 b1 b0	b3 b2 b1 b0	b3 b2 b1 b0	b3 b2 b1 b0
Data	(AR) (μPD17217, 17218) (AR) (μPD17216) (AR) (μPD17215)				(WR)	(BANK) 0 0 0 *	MPE	(IX) *			(RP) *	B C C I C M Y X D P Z E
Initial Value At Reset	0 0 0 0				Undefined	0 0 0 0	0 0 0 0	0 0 0 0	0 0 0 0	0 0 0 0	0 0 0 0	0 0 0 0

*: This bit is fixed to 0 in the μPD17215 and 17216.

2.4.3 General register (GR)

A general register is a 16-word register on the data memory and used for arithmetic operations and transfer of data to and from the data memory.

(1) Configuration of general register

Figure 2-6 shows the configuration of the general register.

A general register occupies 16 nibbles (16 x 4 bits) on a selected row address of the data memory.

The row address is selected by the general register pointer (RP) of the system register. The RP having four significant bits in the μPD17217 and 17218 can point to any row address in the range of 0H to 7H of each bank (BANK0 and BANK1).

In the μPD17215 and 17216, 3 bits are available in the RP. These bits can point to any row address in the range of 0H to 7H of BANK0.

(2) Functions of the general register

The general register enables an arithmetic operation and data transfer between the data memory and a selected general register by a single instruction. As a general register is a part of the data memory, you can say that the general register enables arithmetic operation and data transfer between two locations of the data memory. Similarly, the general register can be accessed by a Data Memory Manipulation instruction as it is a part of the data memory.

Fig. 2-6 Configuration of General Registers

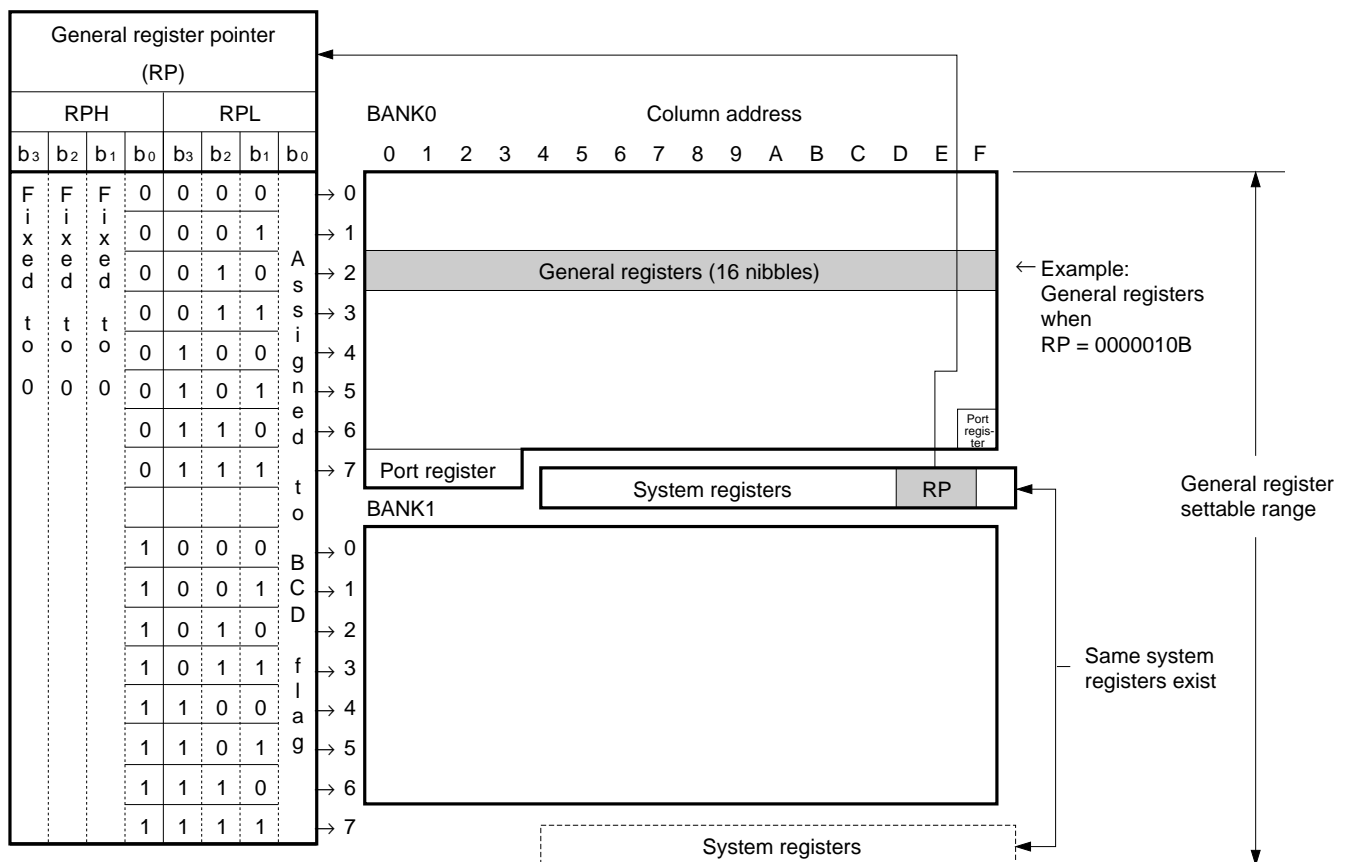

2.4.4 Data buffer (DBF)

The data buffer on the addresses 0CH to 0FH of data memory is used for data transfer to and from peripheral hardware and for storage of data during table reference.

(1) Functions of the Data Buffer

The data buffer has two major functions: a function to transfer to and from hardware and a function to read constant data from the program memory (for table reference). Figure 2-7 shows the relationship between the data buffer and peripheral hardware.

Fig. 2-7 Data Buffer and Peripheral Hardware

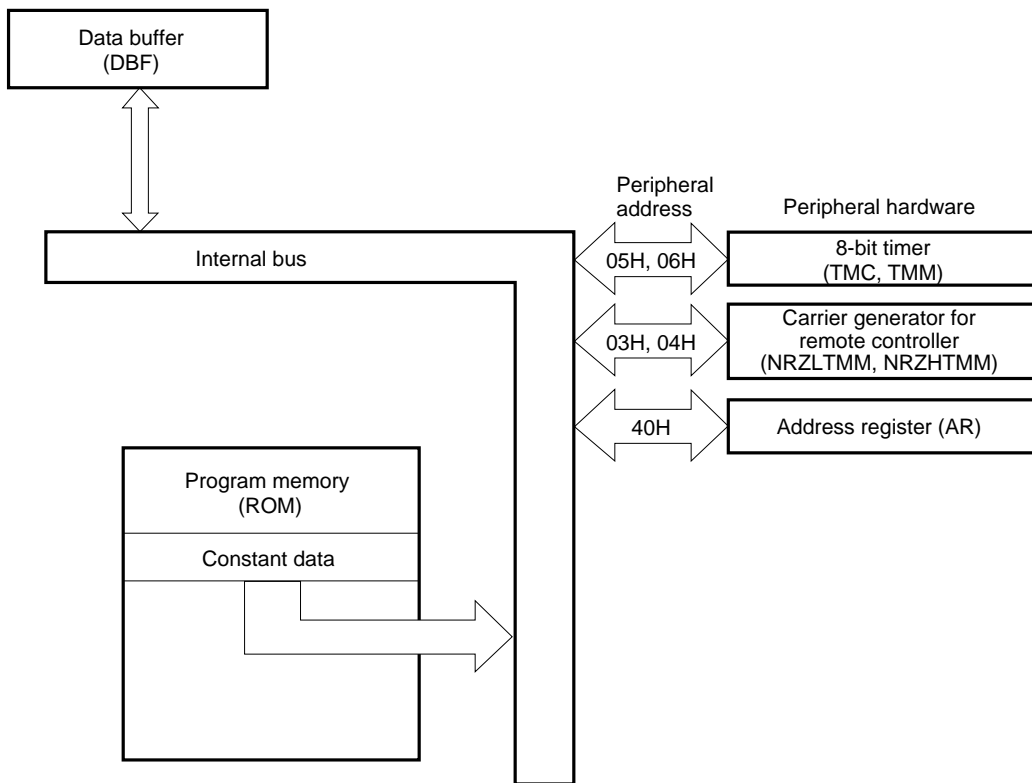

Table 2-2 Relations between Hardware Peripherals and Data Buffer

Hardware Peripherals	Peripheral Register Transferring Data with Data Buffer				
	Name	Symbol	Peripheral Address	Data Buffer	PUT/GET
8-Bit Timer	8-bit counter	TMC	05H	DBF0, DBF1	GET only
	8-bit modulo register	TMM	06H	DBF0, DBF1	PUT only
Remote Controller Carrier Generator	NRZ low level period setting modulo register	NRZLTMM	03H	DBF0, DBF1	PUT GET
	NRZ high level period setting modulo register	NRZHTMM	04H	DBF0, DBF1	PUT (clear bit 3 of DBF1 to 0) GET (bits 3 of DBF1 is always 0)
Address Register	Address register	AR	40H	DBF0-DBF3	PUT (bits 0 to 3 of AR3 and bit 3 of AR2 are any)*1 GET (bits 0 to 3 of AR3 and bit 3 of AR2 are always 0)*2

*1: In the μPD17216: bits 0 to 3 of AR3 are any, in the μPD17217, 17218: bits 1 to 3 of AR3 are any

*2: In the μPD17216: bits 0 to 3 of AR3 are always 0, in the μPD17217, 17218: bits 1 to 3 of AR3 are always 0

(2) Table reference

A MOVT instruction reads constant data from a specified location of the program memory (ROM) and sets it in the data buffer.

The function of the MOVT instruction is explained below.

MOVT DBF, @AR: Reads data from a program memory location pointed to by the address register (AR) and sets it in the data buffer (DBF).

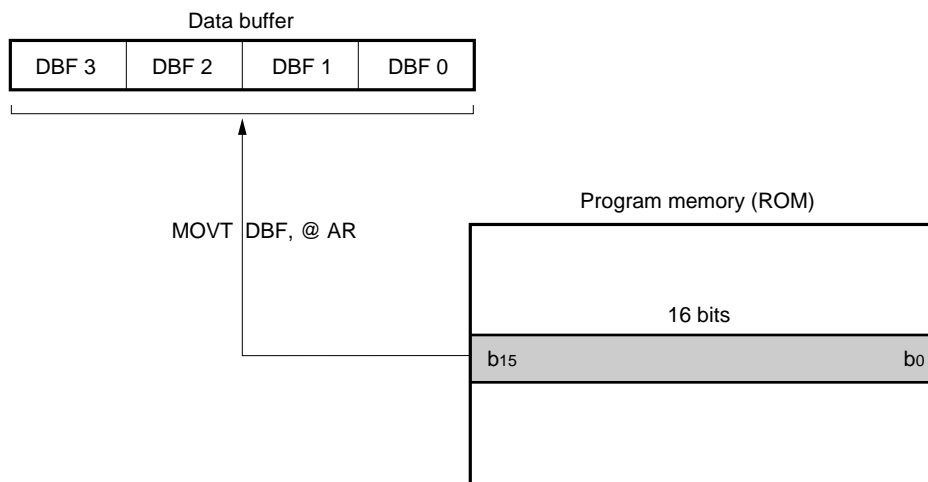

(3) Note on using data buffer

When transferring data to/from the peripheral hardware via the data buffer, the unused peripheral addresses, write-only peripheral registers (only when executing PUT), and read-only peripheral registers (only when executing GET) must be handled as follows:

- When device operates
Nothing changes even if data is written to the read-only register.
If the unused address is read, an undefined value is read. Nothing changes even if data is written to that address.
- Using assembler
An error occurs if an instruction is executed to read a write-only register.
Again, an error occurs if an instruction is executed to write data to a read-only register.
An error also occurs if an instruction is executed to read or write an unused address.
- If an in-circuit emulator (IE-17K or IE-17K-ET) is used (when instruction is executed for patch processing)
An undefined value is read if an attempt is made to read the data of a write-only register, but an error does not occur.
Nothing changes even if data is written to a read-only register, and an error does not occur.
An undefined value is read if an unused address is read; nothing changes even if data is written to this address. An error does not occur.

2.5 Register File (RF)

The register file mainly consists of registers that set the conditions of the peripheral hardware.

These registers can be controlled by dedicated instructions PEEK and POKE, and the embedded macro instructions of AS17K, SETn, CLRn, and INITFLG.

2.5.1 Configuration of register file

Fig. 2-8 shows the configuration of the register file and how the register file is accessed by the PEEK and POKE instructions.

The control registers are controlled by using dedicated instructions PEEK and POKE. Since the control registers are assigned to addresses 00H-3FH regardless of the bank, the addresses 00H-3FH of the general-purpose data memory cannot be accessed when the PEEK or POKE instruction is used.

The addresses that can be accessed by the PEEK and POKE instructions are the addresses 00H-3FH of the control registers and 40H-7FH of the general-purpose data memory. The register file consists of these addresses.

The control registers are assigned to addresses 80H-BFH on the IE-17K to facilitate debugging.

Fig. 2-8 Register File Access with PEEK or POKE Instructions

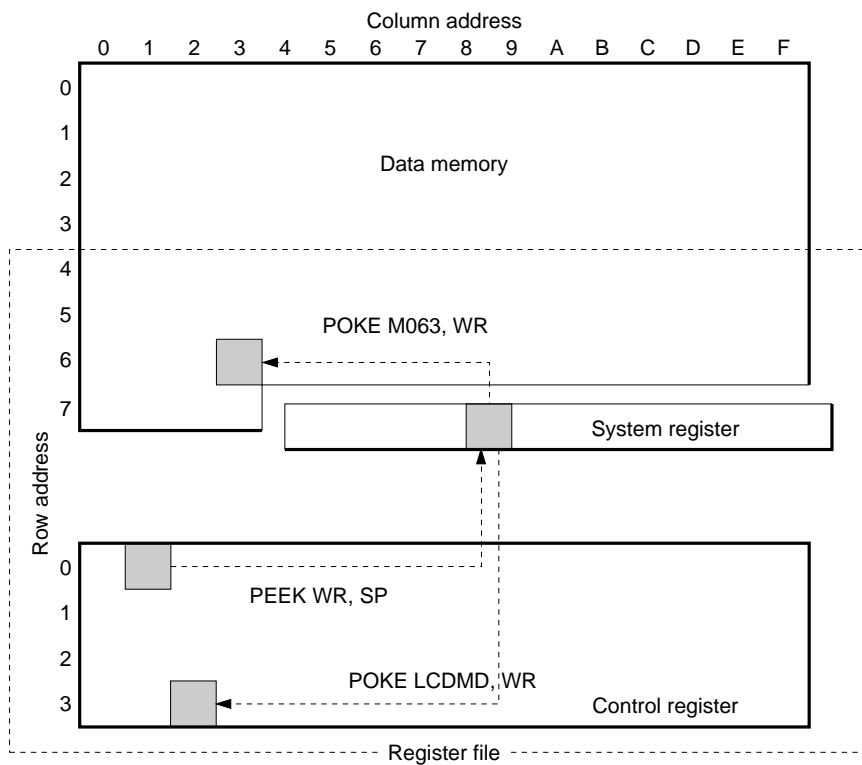

2.5.2 Control registers

The control registers consists of a total of 64 nibbles (64 x 4 bits) of the addresses 00H-3FH of the register file.

Of these, however, only 14 nibbles are actually used. The remaining 50 nibbles are unused registers that are inhibited from being read or written.

When the “PEEK WR, rf” instruction is executed, the contents of the register file addressed by “rf” are read to the window register.

When the “POKE rf, WR” instruction is executed, the contents of the window register are written to the register file addressed by “rf”.

When using the assembler (AS17K), the macro instructions listed below, which are embedded as flag type symbol manipulation instructions, can be used. The macro instructions allow the contents of the register file to be manipulated in bit units.

For the configuration of the control register, refer to Fig. 11-1 Register File List.

- SETn : Sets flag to “1”
- CLRn : Sets flag to “0”
- SKTn : Skips if all flags are “1”
- SKFn : Skips if all flags are “0”
- NOTn : Complements flag
- INITFLG: Initializes flag

2.5.3 Notes on using register files

When using the register files, bear in mind the points described below. For details, refer to μPD172xx subseries User’s Manual (IEU-1317).

- (1) When manipulating control registers (read-only and unused registers)
 - When manipulating the write-only (W), the read-only (R) and unused control registers by using the assembler or in-circuit emulator, keep in mind the following points:
 - When device operates
 - Nothing changes even if data is written to the read-only register.
 - If the unused register is read, an undefined value is read; nothing is changed even if data is written to this register.
 - Using assembler
 - An error occurs if instruction is executed to read data to the write-only register.
 - An error occurs if an instruction is executed to write data to the read-only register.
 - An error also occurs if an instruction is executed to read or write the unused address.
 - When an in-circuit emulator (IE-17K or IE-17K-ET) is used (when instruction is executed for patch processing)
 - An undefined value is read if the write-only register is read, and an error does not occur.
 - Nothing changes even if data is written to the read-only register, and an error does not occur.
 - An undefined value is read if the unused address is read; nothing changes even if data is written to this address. An error does not occur.

(2) Symbol definition of register file

An error occurs if a register file address is directly specified as a numeral by the operand “rf” of the “PEEK WR, rf” or “POKE rf, WR” instruction if the 17K Series Assembler (AS17K) is being used.

Therefore, the addresses of the register file must be defined in advance as symbols.

To define the addresses of the control registers as symbols, define them as the addresses 80H-BFH of BANK0. The portion of the register file overlapping the data memory (40H-7FH), however, can be defined as symbols as is.

3. PORTS

3.1 Port 0A (P0A₀-P0A₃)

This is a 4-bit input port. Data is read through port register P0A (address 70H). This port is a CMOS input port with a pull-up resistor, and can be used for key return input for a key matrix.

When a low-level signal is input to at least one of the pins in this port in the standby mode, the standby mode is released.

3.2 Port 0B (P0B₀-P0B₃)

This is a 4-bit input port. Data is read through port register P0B (address 71H). This port is a CMOS input port with a pull-up resistor, and can be used for key return input for a key matrix.

When a low-level signal is input to at least one of the pins in this port in the standby mode, the standby mode is released.

3.3 Port 0C (P0C₀-P0C₃)

This is a 4-bit output port. The contents of the output latch are read and output data is set through port register P0C (address 72H). This port is an N-ch open-drain output port, and can be used as the key source of a key matrix.

In the standby mode, this port outputs low-level signals.

3.4 Port 0D (P0D₀-P0D₃)

This is a 4-bit output port. The contents of the output latch are read and output data is set through port register P0D (address 73H). This port is an N-ch open-drain output port, and can be used as the key source for a key matrix.

In the standby mode, this port outputs low-level signals.

3.5 Port 0E (P0E₀-P0E₃)

This is a 4-bit I/O port which can be set in either the input or output mode in 1-bit units by the P0EBIO (address 27H) of the register file.

To read the input data or to set the output data, use the P0E register (address 6F). When data is read in the output mode, the contents of the output latch are read.

Connection of a pull-up resistor can be specified in 1-bit units by the P0EBPU (address 17H) of the register file. (When the pull-up resistor is connected, note that the pull-up resistor is not disconnected even when the output mode is set.)

On reset, this port functions as an input port.

3.6 INT Pin

This pin inputs an external interrupt request signal. At either the rising or falling edge of the signal input to this pin, the IRQ flag (RF: address 3EH, bit 0) is set.

The status of this pin can be read by using the INT flag (RF: address 0FH, bit 0). When the high level is input to the pin, the INT flag is set to “1”; when the low level is input, the flag is reset to “0” (refer to 7.2.1 INT).

Fig. 3-1 Relations between Port Register and Each Pin

Bank	Address	Port	Bit	Output Form	Contents to Be Read		Contents to Be Written		On Reset					
					Input Mode	Output Mode	Input Mode	Output Mode						
0	70H	Port 0A	b ₃	P0A ₃	Input only	Pin status	---	---	Input mode (w/pull-up resistor)					
			b ₂	P0A ₂										
			b ₁	P0A ₁										
			b ₀	P0A ₀										
	71H	Port 0B	b ₃	P0B ₃										
			b ₂	P0B ₂										
			b ₁	P0B ₁										
			b ₀	P0B ₀										
	72H	Port 0C	b ₃	P0C ₃						N-ch open-drain (Output only)	---	---	---	Output mode (Low level output)
			b ₂	P0C ₂										
			b ₁	P0C ₁										
			b ₀	P0C ₀										
	73H	Port 0D	b ₃	P0D ₃										
			b ₂	P0D ₂										
			b ₁	P0D ₁										
			b ₀	P0D ₀										
6FH	Port 0E	b ₃	P0E ₃	COMS push-pull	Pin status	---	Output latch	Input mode (w/pull-up resistor)						
		b ₂	P0E ₂											
		b ₁	P0E ₁											
		b ₀	P0E ₀											

3.7 Switching Bit I/O

The I/O which can be set in the input or output mode in bit units is called a bit I/O. P0E is a bit I/O port, which can be set in the input or output mode in bit units by the register file shown below. When the mode is changed from input to output, the P0E output latch contents are output to the port lines, as soon as the mode has been changed.

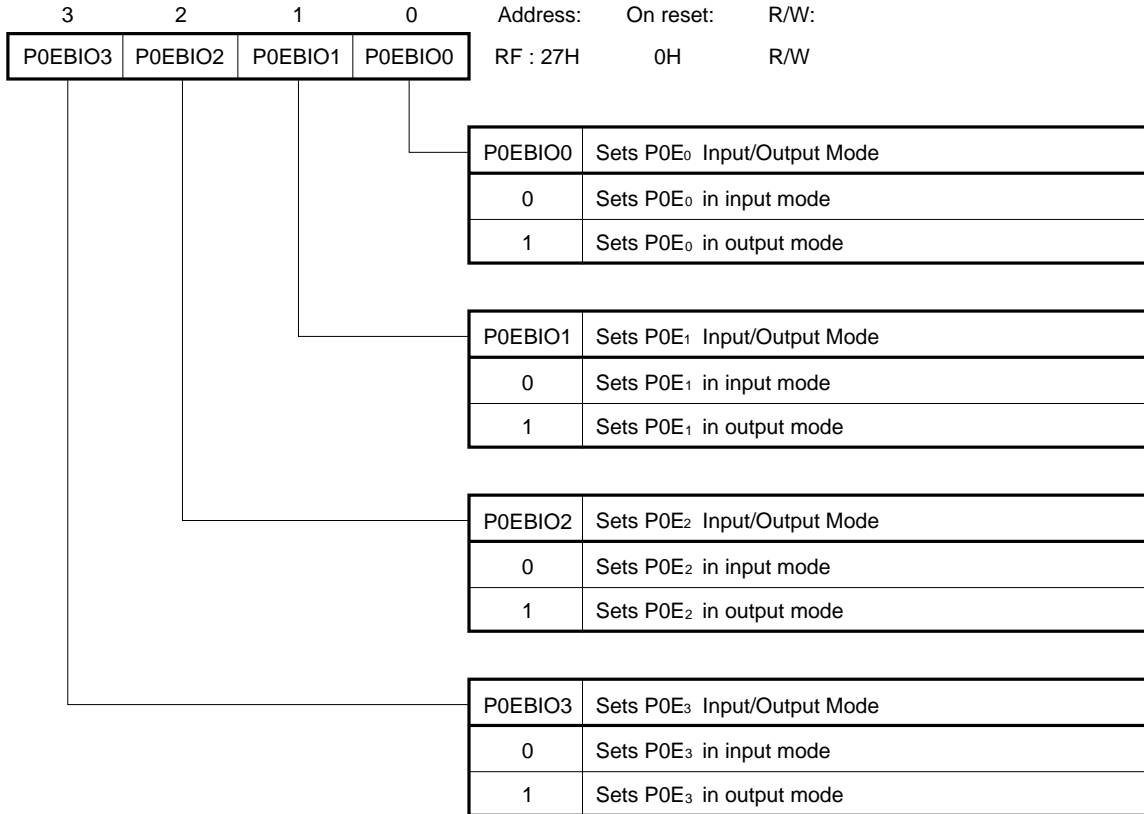

3.8 Specifying Pull-up Resistor Connection

Whether or not a pull-up resistor is connected to port P0E can be specified by the following registers of the register file in 1-bit units when the port is in the input mode*.

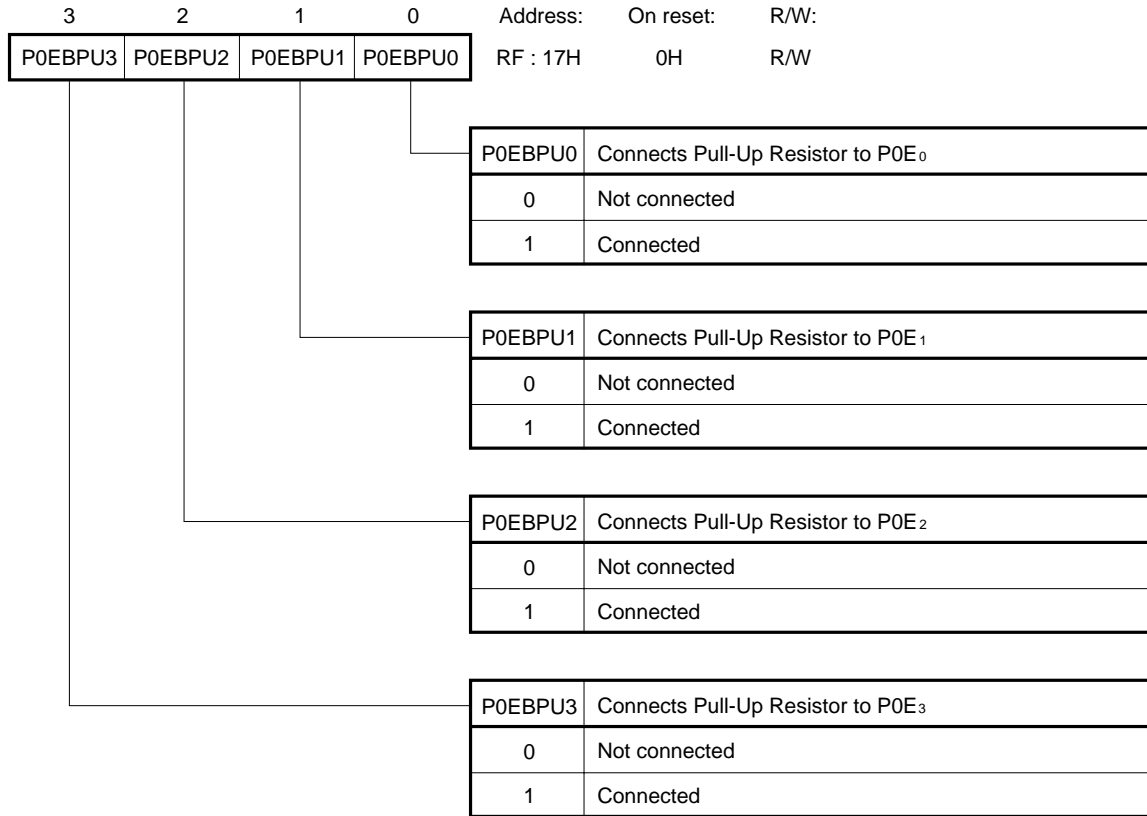

*: To disconnect the pull-up resistor in the output mode, clear the corresponding bit of the P0EBPU register.

4. CLOCK GENERATOR CIRCUIT

4.1 Instruction Execution Time (CPU Clock) Selection

The μPD17215 is equipped with a clock oscillator circuit that supplies clocks to the CPU and hardware peripherals. Instruction execution time can be changed in two steps (ordinary mode and high-speed mode) without changing the oscillation frequency.

To change the instruction execution time, change the mode of SYSCK (RF: address 02H) of the register file by using the POKE instruction.

Note, that the mode is actually only changed when the instruction next to the POKE instruction has been executed.

When using the high-speed mode, pay attention to the supply voltage. (Refer to 13. ELECTRICAL SPECIFICATIONS.)
At reset, the ordinary mode is set.

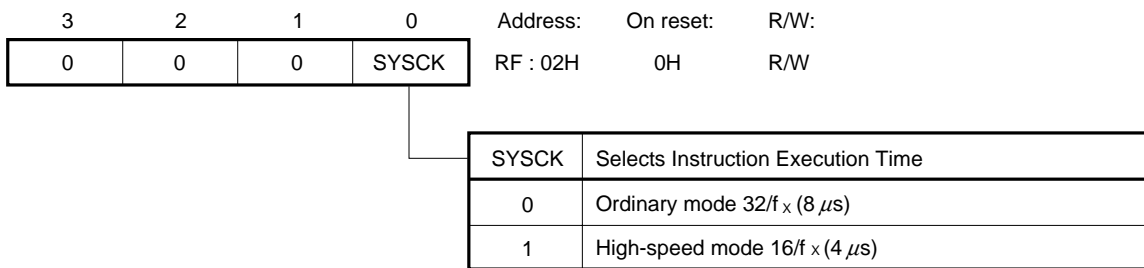

Figures in (): indicate figures when system clock $f_x = 4$ MHz.

5. 8-BIT TIMER AND REMOTE CONTROLLER CARRIER GENERATOR CIRCUIT

The μPD17215 is equipped with the 8-bit timer which is mainly used to generate the leader pulse of the remote controller signal, and to output codes.

5.1 Configuration of 8-bit Timer (with modulo function)

Figure 5-1 shows the configuration of the 8-bit timer.

As shown in this figure, the 8-bit timer consists of an 8-bit counter (TMC), an 8-bit modulo register (TMM), a comparator that compares the value of the timer with the value of the modulo register, and a selector that selects the operation clock of the 8-bit timer.

To start/stop the 8-bit timer, and to reset the 8-bit counter, TMEN (address 33H, bit 3) and TMRES (address 33H, bit 2) of the register file are used. To select the operation clock of the 8-bit timer, use TMCK1 (address 33H, bit 1) and TMCK0 (address 33H, bit 0) of the register file.

The value of the 8-bit counter is read by using the GET instruction through DBF (data buffer). No value can be set to the 8-bit counter. A value is set to the modulo register by using the PUT instruction through DBF. The value of the modulo register cannot be read.

When the value of the counter coincides with that of the modulo register, an interrupt flag (IRQTM: address 3FH, bit 0) of the register file is set.



Caution: Do not clear TMM to 0 (IRQTM is not set).

Fig. 5-1 Configuration of 8-bit Timer and Remote Controller Carrier Generator Circuit

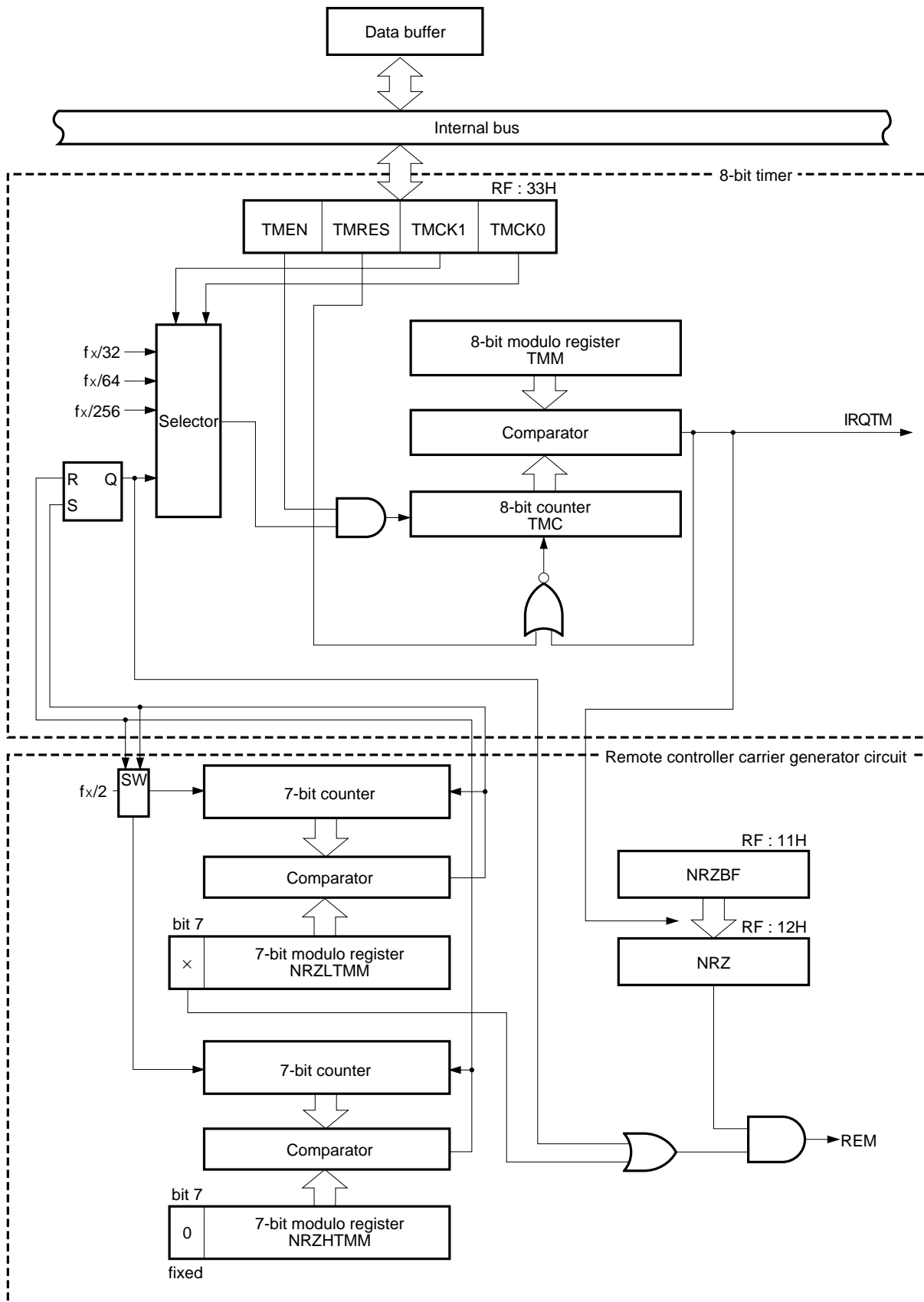

Remark: TMM, TMC, NRZLTMM, and NRZHTMM are peripheral registers.

5.2 Function of 8-bit Timer (with modulo function)

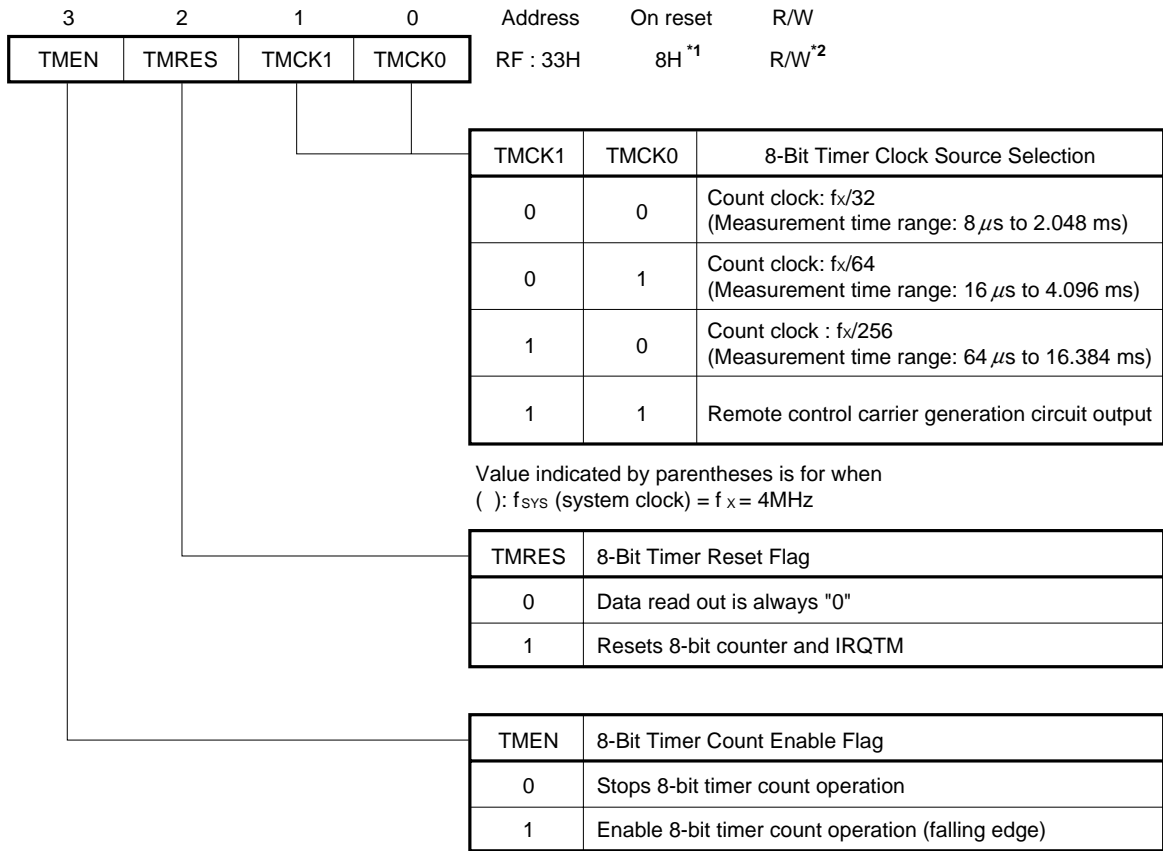

*1: When the STOP mode is released, bit 3 must be set.
 *2: Bit 2 is a write-only bit.

NRZLTMM

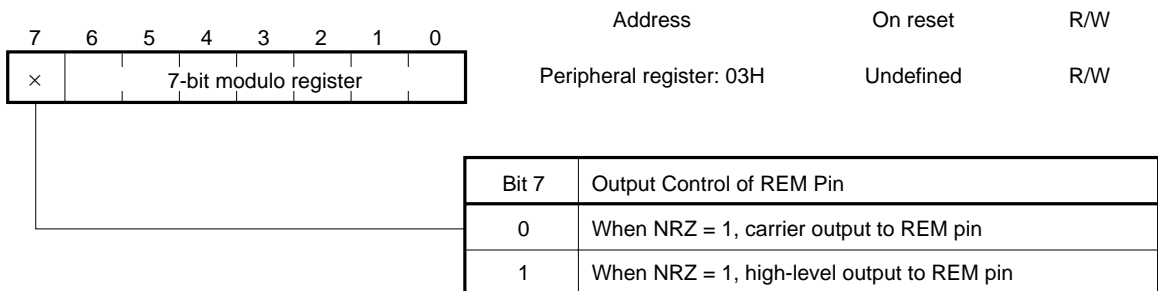

NRZHTMM

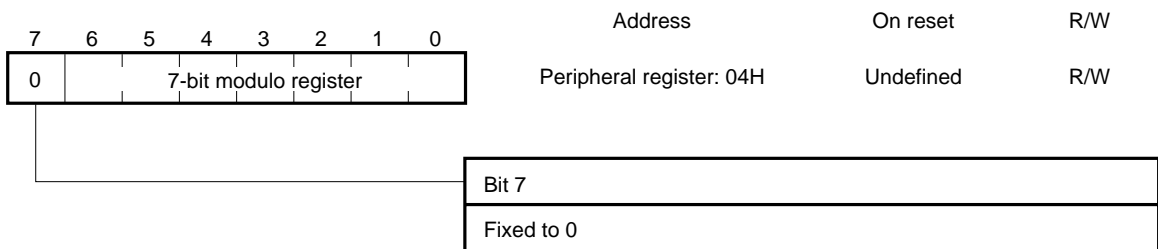

5.3 Carrier Generator Circuit for Remote Controller

μ PD17215 is provided with a carrier generator circuit for the remote controller.

The remote controller carrier generator circuit consists of a 7-bit counter, NRZ high-level period setting modulo register (NRZHTMM), and NRZ low-level period setting modulo register (NRZLTMM). The high-level and low-level periods are set in the corresponding modulo registers through the DBF to determine the carrier duty factor and carrier frequency.

The system clock (f_x) is divided by two and is input to the 7-bit counter. Therefore, when a 4-MHz oscillator is used, 2 MHz (0.5 μ s) is input to the counter as the clock; when a 32-kHz oscillator (f_{XT}) is used, 16 kHz is input.

The NRZ high-level output period setting modulo register is called NRZHTMM, and the NRZ low-level period setting modulo register is called NRZLTMM. Data is written to these registers by the PUT instruction. The contents for these register are read by the GET instruction.

Bit 7 of NRZLTMM specifies whether the carrier or high level is output to the REM pin. To output the carrier, be sure to clear bit 7 to 0.

5.3.1 Remote controller signal output control

The REM pin, which outputs the carrier, is controlled by bits NRZ and NRZBF for the register file and timer 0. While the NRZ content is "1", the clock generated by the remote controller carrier generator circuit is output to the REM pin; while the NRZ content is "0", the REM pin outputs a low level. The NRZBF content is automatically transferred to NRZ by the interrupt signal generated by timer 0. If data is set in NRZBF in advance, the REM pin status changes in synchronization with the timer 0 counting operation.

If the interrupt signal is generated from timer 0 with the REM pin at the high level, NRZ being "1", and the carrier clock at the high level, the REM pin output is not in accordance with the updated content of NRZ, until the carrier clock goes low. This processing is useful for holding the high level pulse width from the output carrier constant (refer to the figure below).

When the content of NRZ is "0", the remote controller carrier generator circuit stops. However, if the clock for timer 0 is output from the remote controller carrier generator circuit, the clock continues to operate, even when the NRZ content becomes "0".

An actual example showing a remote controller signal output to the REM pin is presented below.

When bit 7 of NRZLTMM is 0 (carrier output)

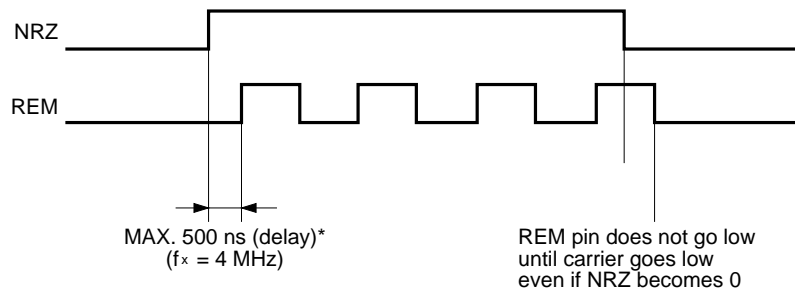

*: Value when (TMCK1, TMCK0) \neq (1, 1).

When (TMCK1, TMCK0) = (1, 1), the value differs depending on how NRZ is manipulated. If NRZ is set by an instruction, the width of the first high-level pulse may be shortened. If NRZ is set by data transferred from NRZBF, the high-level pulse is delayed by the low-level pulse of the carrier clock.

When bit 7 of NRZLTMM is 0 (carrier not output)

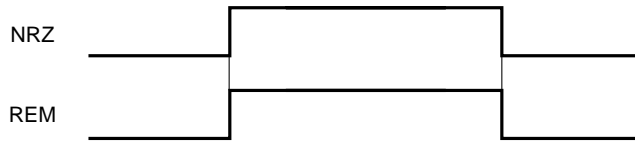

3	2	1	0	Address	On reset	R/W
0	0	0	NRZ	RF : 12H	0H	R/W

NRZ	NRZ Data
0	Outputs low level to REM pin
1	Outputs a carrier to REM pin or high level output

3	2	1	0	Address	On reset	R/W
0	0	0	NRZBF	RF : 11H	0H	R/W

NRZBF	NRZ Data Output Next
0	NRZ buffer bit. Transferred to NRZ by interrupt signal for 8-bit timer.
1	

Setting carrier frequency and duty factor

Where the system clock frequency is f_x and carrier frequency is f_c :

$$\ell \text{ (division ratio)} = f_x / (2 \times f_c)$$

ℓ is divided into m:n and is set in the modulo registers as follows:

$$\text{High-level period set value} = \{\ell \times m / (m + n)\} - 1$$

$$\text{Low-level period set value} = \{\ell \times n / (m + n)\} - 1$$

Example: Where $f_c = 38 \text{ kHz}$, duty factor (high-level period) = 1/3, and $f_x = 4 \text{ MHz}$,

$$\ell = 4 \text{ MHz} / (2 \times 38 \text{ kHz}) = 52.6$$

$$m:n = 1:2$$

From the above, the value of the modulo register is:

$$\text{High-level period} \approx 17$$

$$\text{Low-level period} \approx 34$$

Therefore, the carrier frequency is 37.74 kHz.

Table 5-1 Carrier Frequency List ($f_x = 4 \text{ MHz}$)

Set value		$t_H (\mu s)$	$t_L (\mu s)$	$1/f_c (\mu s)$	$f_c (\text{kHz})$	Duty
NRZHTMM	NRZLTMM					
00H	00H	0.5	0.5	1.0	1000	1/2
01H	02H	1.0	1.5	2.5	400	2/5
04H	04H	2.5	2.5	5.0	200	1/2
09H	09H	5.0	5.0	10.0	100	1/2
0FH	10H	8.0	8.0	16.5	60.6	1/2
0FH	21H	8.0	17.0	25.0	40.0	1/3
11H	21H	9.0	17.0	26.0	38.5	1/3
11H	22H	9.0	17.5	26.5	37.7	1/3
19H	35H	13.0	27.0	40.0	25.0	1/3
3FH	3FH	32.0	32.0	64.0	15.6	1/2
7FH	7FH	64.0	64.0	120.0	7.8	1/2

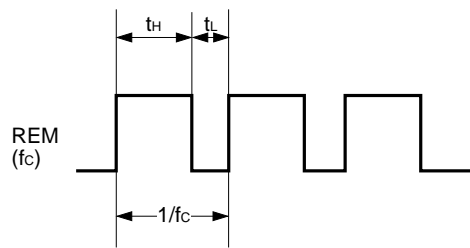

5.3.2 Countermeasures against noise during transmission (carrier output)

When a signal is transmitted from the transmitter of a remote controller, a peak current of 0.5 to 1 A may flow through the infrared LED. Since two batteries are usually used as the power source of the transmitter, several Ω of equivalent resistance (r) exists in the power source as shown in Fig. 5-2. This resistance increases to 10 to 20 Ω if the supply voltage drops to 2 V. While the carrier is output from the REM pin (while the infrared LED lights), therefore, a high-frequency noise may be generated on the power lines due to the voltage fluctuation that may take place especially during switching.

To minimize the influence on the microcontroller of this high-frequency noise, take the following measures:

- <1> Separate the power lines of the microcontroller from the power lines of the infrared LED with the terminals of the batteries at the center. Use thick power lines and keep the wiring short.
- <2> Locate the oscillator as close as possible to the microcontroller and shield it with GND lines (as indicated by the shaded portion in the figure below).
- <3> Locate the capacitor for stabilization of the power supply closely to the power lines of the microcontroller. Also, use a capacitor to eliminate high-frequency noise.
- <4> To prevent data from changing, do not execute an interrupt that requires read/write processing and stack, such as key scan interrupt, and the CALL/RET instruction, while the carrier is output.
- <5> To improve the reliability in case of program hang-up, use the watchdog timer (connect the $\overline{\text{WDOUT}}$ and $\overline{\text{RESET}}$ pins).

Fig. 5-2 Example of Countermeasures against Noise

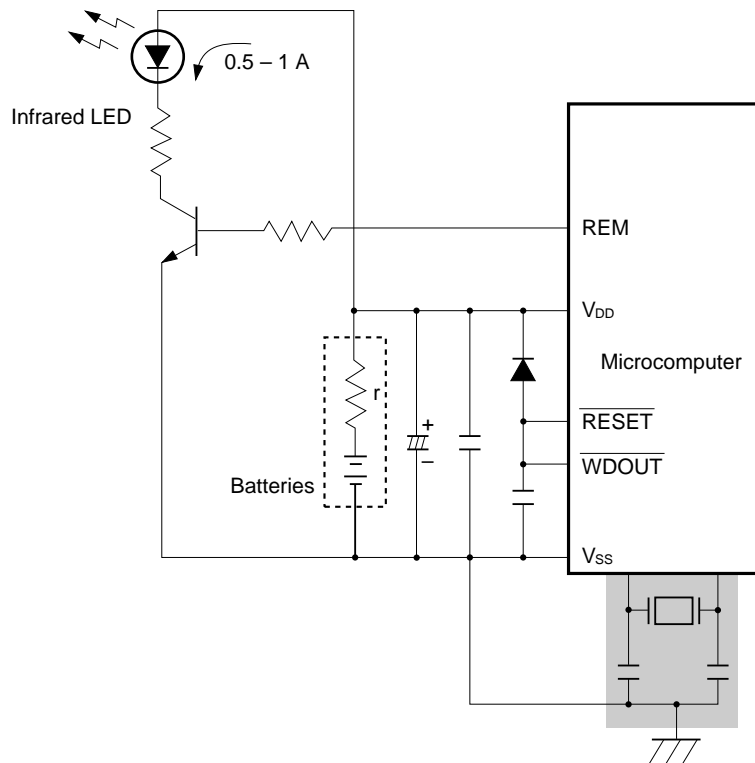

- Remarks**
- 1: The INT and $\overline{\text{RESET}}$ pins are multiplexed with test pins (refer to 1.4 NOTES ON USING OF INT AND $\overline{\text{RESET}}$ PINS).
 - 2: In this figure, the $\overline{\text{RESET}}$ pin is connected to a pull-up resistor by mask option.

6. BASIC INTERVAL TIMER/WATCHDOG TIMER

The basic interval timer has a function to generate the interval timer interrupt signal and watchdog timer reset signal.

6.1 Source Clock for Basic Interval Timer

The system clock (f_x) is divided, to generate the source clock for the basic interval timer. The input clock frequency for the basic interval timer is $f_x/2^7$. When the CPU is set in the STOP mode, the basic interval timer also stops.

6.2 Controlling Basic Interval Timer

The basic interval timer is controlled by the bits on the register file. That is, the basic interval timer is reset by BTMRES. The frequency for the interrupt signal, output by the basic interval timer, is selected by BTMMD, and the watchdog timer is reset by WDTRES.

Fig. 6-1 Basic Interval Timer Configuration

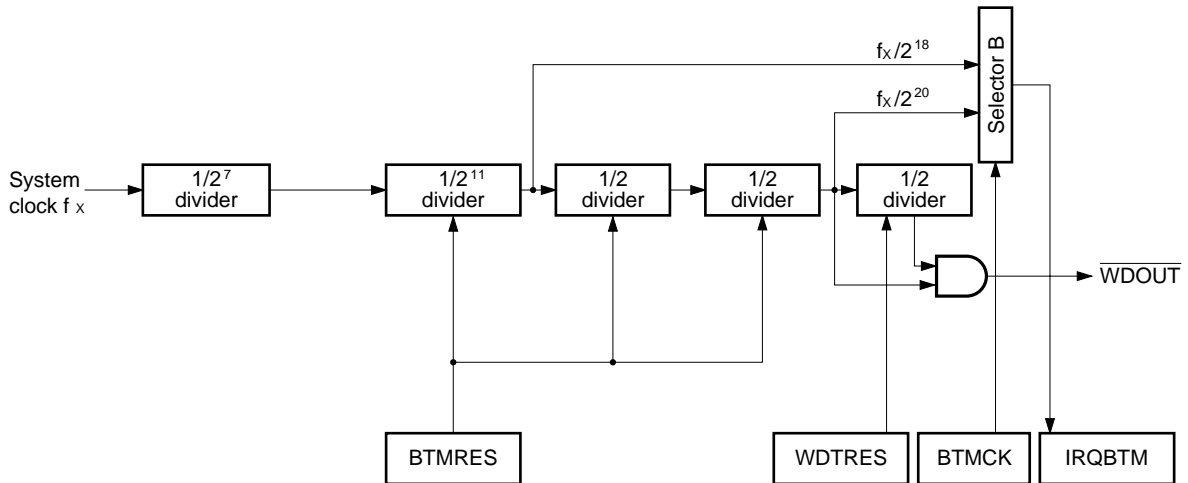

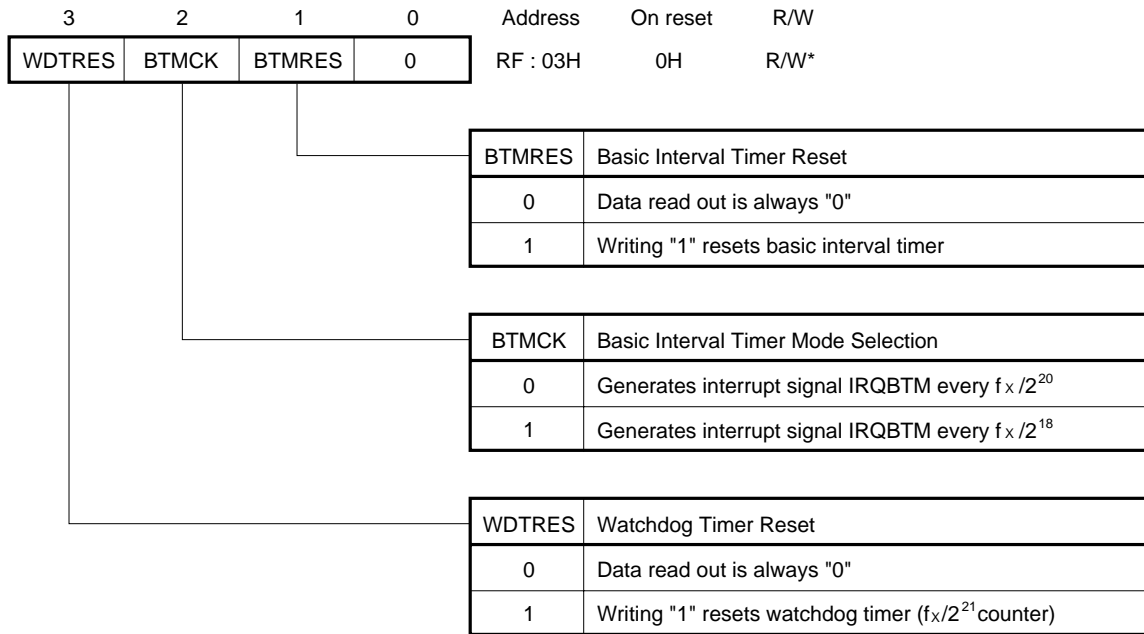

*: Bits 1 and 3 are write-only bits.

6.3 Operation Timing for Watchdog Timer

The basic interval timer can be used as a watchdog timer.

Unless the watchdog timer is reset within a fixed time*, it judges that “the program has hung up”, and the μ PD17215 is reset. It is therefore necessary to reset through programming the watchdog timer within a fixed time.

The watchdog timer can be reset by setting WDTRES to 1.

*: Fixed time: approx. 340 ms (at 4 MHz)

- Cautions 1:** The watchdog timer cannot be reset in the shaded range in Fig. 6-2. Therefore, set WDTRES before both the $f_x/2^{21}$ and $f_x/2^{20}$ signals go high.
- 2:** Refer to 9. RESET for the $\overline{\text{WDOUT}}$ pin function.

Fig. 6-2 Watchdog Timer Operation Timing

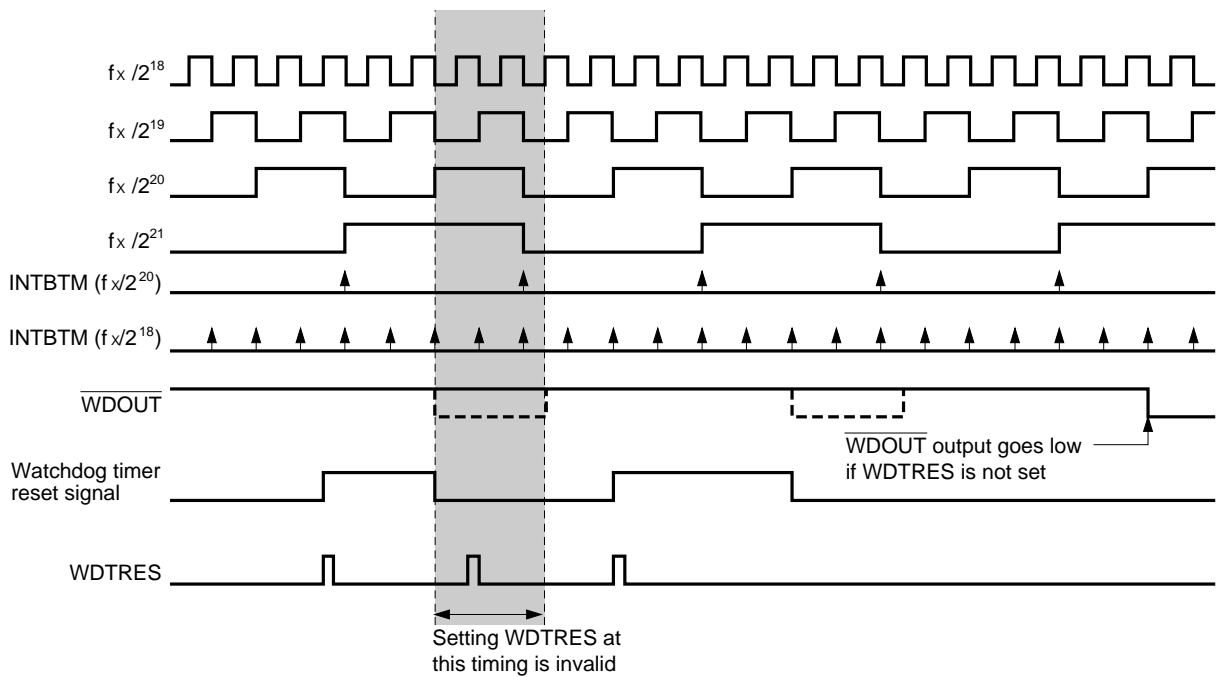

7. INTERRUPT FUNCTIONS

7.1 Interrupt Sources

μPD17217 is provided with three interrupt sources.

When an interrupt has been accepted, the program execution automatically branches to a predetermined address, which is called a vector address. A vector address is assigned to each interrupt source, as shown in Table 7-1.

Table 7-1 Vector Address

Priority	Interrupt Source	Ext/Int	Vector Address
1	8-bit timer	Internal	0003H
2	INT pin rising and falling edges	External	0002H
3	Basic interval timer	Internal	0001H

When more than one interrupt request is issued at the same time, the interrupts are accepted in sequence, starting from the one with the highest priority.

Whether an interrupt is enabled or disabled is specified by the EI or DI instruction. The basic condition under which an interrupt is accepted is that the interrupt is enabled by the EI instruction. While the DI instruction is executed, or while an interrupt is accepted, the interrupt is disabled.

To enable accepting an interrupt after the interrupt has been processed, the EI instruction must be executed before the RETI instruction. Accepting the interrupt is enabled by the EI instruction after the instruction next to the EI instruction has been executed. Therefore, no interrupt can be accepted between the EI and RETI instructions.

Caution: In interrupt processing, only the BCD, CMP, CY, Z, IXE flags are automatically saved to the stack by the hardware, to a maximum of three levels. Also, within the interrupt processing contents, when peripheral hardware (timer, A/D converter, etc.) is accessed, the DBF and WR contents are not saved by the hardware. Accordingly, it is recommended that at the beginning of interrupt processing DBF and WR be saved by software to RAM, and immediately before finishing interrupt processing the saved contents be returned to their original location.

7.2 Hardware of Interrupt Control Circuit

This section describes the flags of the interrupt control circuit.

(1) Interrupt request flag and interrupt enable flag

The interrupt request flag (IRQxxx) is set to 1 when an interrupt request is generated, and is automatically cleared to 0 when the interrupt processing is executed.

An interrupt enable flag (IPxxx) is provided to each interrupt request flag. When the IPxxx flag is 1, the interrupt is enabled; when it is 0, the interrupt is disabled.

(2) EI/DI instruction

Whether an accepted interrupt is executed or not is specified by the EI or DI instruction.

When the EI instruction is executed, INTE (interrupt enable flag), which enables the interrupt, is set to 1. The INTE flag is not registered on the register file. Consequently, the status of this flag cannot be checked by an instruction.

The DI flag clears the INTE flag to 0 to disable all the interrupts.

The INTE flag is also cleared to 0 at reset, disabling all the interrupts.

Table 7-2 Interrupt Request Flags and Interrupt Enable Flag

Interrupt Request Flag	Signal Setting Interrupt Request Flag	Interrupt Enable Flag
IRQTM	Reset by 8-bit timer.	IPTM
IRQ	Set when edge of INT pin input signal is detected	IP
IRQBTM	Reset by basic interval timer.	IPBTM

7.2.1 INT

This flag reads the INT pin status.

When a high level is input to the INT pin, this flag is set to “1”; when a low level is input, the flag is reset to “0”.

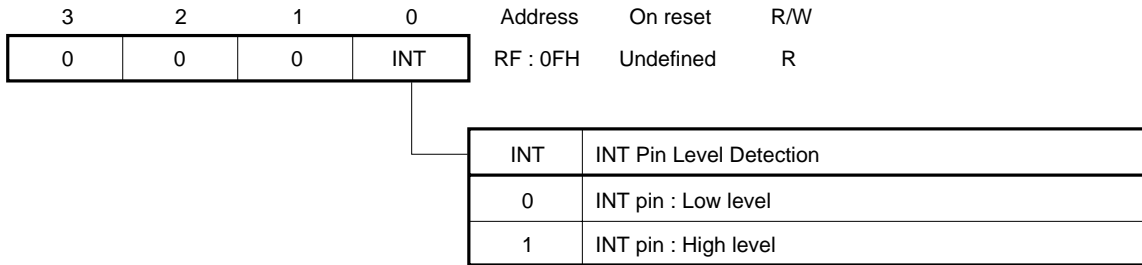

7.2.2 IEG

This pin selects the interrupt edge to be detected on the INT pin.

When this flag is “0”, the interrupt is detected at the rising edge; when it is “1”, the interrupt is detected at the falling edge.

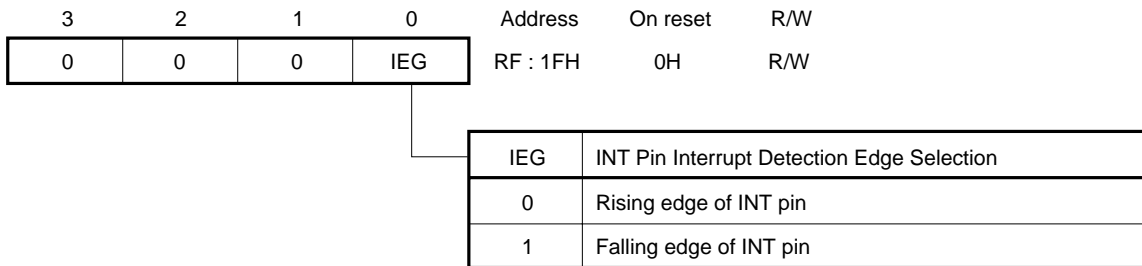

7.2.3 Interrupt enable flag

This flag enables each interrupt source. When this flag is “1”, the corresponding interrupt is enabled; when it is “0”, the interrupt is disabled.

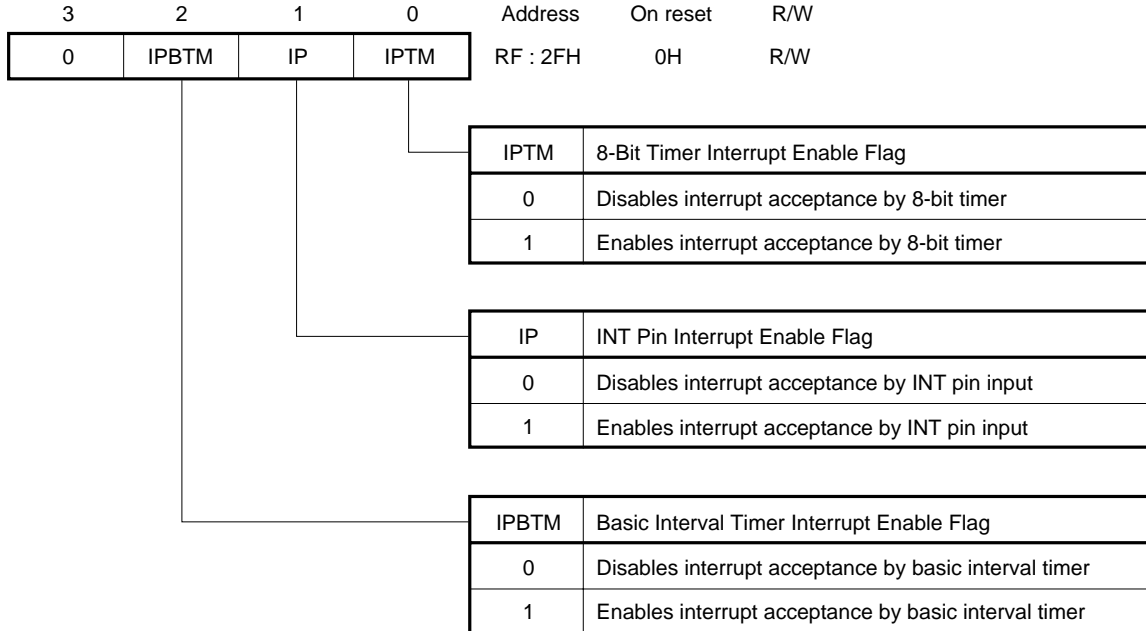

7.2.4 IRQ

This is an interrupt request flag that indicates the interrupt request status.

When an interrupt request is generated, this flag is set to “1”. When the interrupt has been accepted, the interrupt request flag is reset to “0”.

The interrupt request flag can be read or written by the program. Therefore, when it is set to “1”, an interrupt can be generated by the software. By writing “0” to the flag, the interrupt pending status can be canceled.

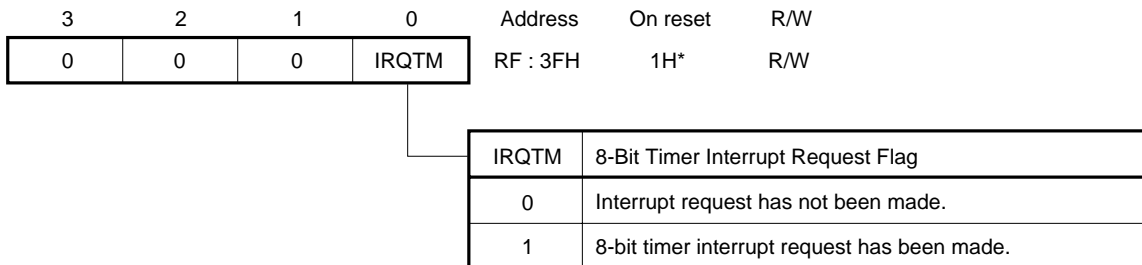
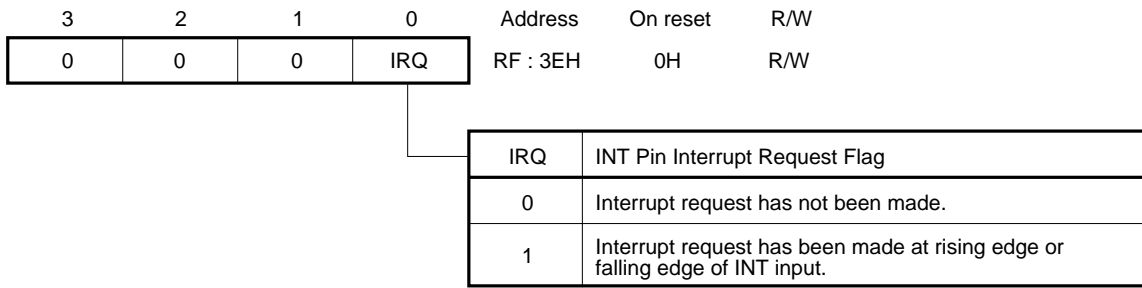
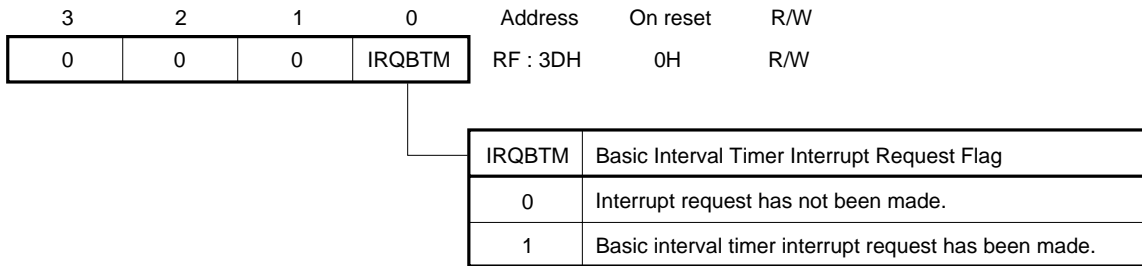

*: 1H is also set after releasing STOP mode.

7.3 Interrupt Sequence

If IRQ_{xxx} flag is set to "1" when IP_{xxx} flag is "1", interrupt processing is started after the instruction cycle of the instruction executed when IRQ_{xxx} flag was set has ended. Since the MOVT instruction, EI instruction, and the instruction which matches the condition to skip use two instruction cycles, the interrupt enabled while this instruction is executed is processed after the second instruction cycle is over.

If IP_{xxx} flag is "0", the interrupt processing is not performed even if IRQ_{xxx} flag is set, until IP_{xx} flag is set.

If two or more interrupts are enabled simultaneously, the interrupts are processed starting from the one with the highest priority. The interrupt with the lower priority is kept pending until the processing of the interrupt with the higher priority is finished.

7.3.1 Operations when interrupt is accepted

When an interrupt has been accepted, the CPU performs processing in the following sequence:

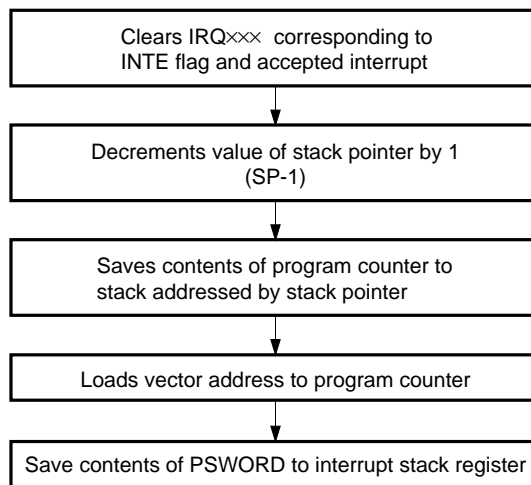

One instruction cycle is required to perform the above processing.

7.3.2 Returning from interrupt processing routine

To return from an interrupt processing routine, use the RETI instruction.
Then the following processing is executed within an instruction cycle.

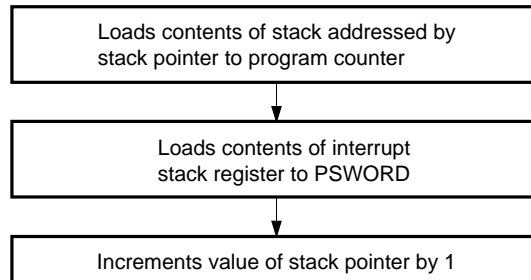

To enable an interrupt after the processing of an interrupt has been finished, the EI instruction must be executed immediately before the RETI instruction.

Accepting the interrupt is enabled by the EI instruction after the instruction next to the EI instruction has been executed. Therefore, the interrupt is not accepted between the EI and RETI instructions.

8. STANDBY FUNCTIONS

μPD17215 is provided with HALT and STOP modes as standby functions. By using the standby function, current dissipation can be reduced.

In the HALT mode, the program is not executed, but the system clock f_x is not stopped. This mode is maintained, until the HALT mode release condition is satisfied.

In the STOP mode, the system clock is stopped and program execution is stopped. This mode is maintained, until the STOP mode release condition is satisfied.

The HALT mode is set, when the HALT instruction has been executed. The STOP mode is set, when the STOP instruction has been executed.

8.1 HALT Mode

In this mode, program execution is temporarily stopped, with the main clock continuing oscillating, to reduce current dissipation. Use the HALT instruction to set the HALT mode.

The HALT mode releasing condition can be specified by the operand for the HALT instruction, as shown in Table 8-1.

After the HALT mode has been released, the operation is performed as shown in Table 8-1 and Figure 8-2.

Caution: Do not execute an instruction that clears the interrupt request flag (IRQxxx) for which the interrupt enable flag (IPxxx) is set immediately before the HALT 8H instruction; otherwise, the HALT mode may not be set.

Table 8-1 HALT Mode Releasing Conditions

Operand Value	Releasing Conditions
0010B (02H)	When interrupt request (IRQTM) occurs for 8-bit timer
1000B (08H)	<1> When interrupt request (IRQTM, IRQWTM, or IRQ), whose interrupt enable flag (IPTM, IPBTM, or IP) is set, occurs <2> When any of P0A ₀ -P0A ₃ and P0B ₀ -P0B ₃ pins goes low
Other Than Above	Inhibited

Table 8-2 Operations After HALT Mode Release (1/2)

(a) HALT 08H

HALT Mode Released by:	Interrupt Status	Interrupt Enable Flag	Operations after HALT Mode Release
Low-Level Input of P0A ₀ -P0A ₃ , P0B ₀ -P0B ₃	Don't care	Don't care	Instruction next to HALT is executed
When Release Condition Is Satisfied by Interrupt	DI	Disabled	Standby mode is not released
		Enabled	Instruction next to HALT is executed
	EI	Disabled	Standby mode is not released
		Enabled	Branches to interrupt vector address

Table 8-2 Operations After HALT Mode Release (2/2)

(b) HALT 02H

HALT Mode Released by:	Interrupt Status	Interrupt Enable Flag	Operations after HALT Mode Release
8-Bit Timer	DI	Disabled	Instructions are executed from the instruction next to the HALT instruction.
		Enabled	
	EI	Disabled	Branches to interrupt vector address
		Enabled	

8.2 HALT Instruction Execution Conditions

The HALT instruction can be executed, only under special conditions, as shown in Table 8-3, to prevent the program from hangup.

If the conditions in Table 8-3 are not satisfied, the HALT instruction is treated as an NOP instruction.

Table 8-3 HALT Instruction Execution Conditions

Operand Value	Execution Conditions
0010B (02H)	When all interrupt request flags (IRQTM) of 8-bit timer are reset
1000B (08H)	<1> When interrupt request flag is reset, corresponding to interrupt whose interrupt enable flag (IPTM, IPBTM, or IP) is set <2> When high level is input to all P0A0-P0A3 and P0B0-P0B3 pins
Other Than Above	Inhibited

8.3 STOP Mode

In the STOP mode, the system clock (f_x) oscillation is stopped and the program execution is stopped to minimize current dissipation.

To set the STOP mode, use the STOP instruction.

The STOP mode releasing condition can be specified by the STOP instruction operand, as shown in Table 8-4.

After the STOP mode has released, the operation is performed as follows:

- <1> Resets IRQTM.
- <2> Starts the basic interval timer and watchdog timer (does not reset).
- <3> Resets and starts the 8-bit timer.
- <4> Executes the instruction next to [STOP 8H] when the current value of the 8-bit counter coincides with the value of the modulo register (IRQTM is set).

The μPD17215 oscillator circuit is stopped, when the STOP instruction has been executed (i.e., in the STOP mode). Oscillation is not resumed, until the STOP mode is released. After the STOP mode has been released, the HALT mode is set. Set the time required to release the HALT mode by using the timer with modulo function.

The time that elapses, after the STOP mode has been released by occurrence of an interrupt, until an operation mode is set, is shown in the following table.

8-Bit Modulo Register Set Value (TMM)	Time Required to Set Operation Mode after STOP Mode Release
	At 4 MHz
40H	4.160 ms (64 μs × 65)
FFH	16.384 ms (64 μs × 256)

Remark: Set the 8-bit modulo timer before executing STOP instruction.

Caution: Do not execute an instruction that clears the interrupt request flag (IRQxxx) for which the interrupt enable flag (IPxxx) is set immediately before the STOP 8H instruction; otherwise, the STOP mode may not be set.

Table 8-4 STOP Mode Releasing Conditions

Operand Value	Releasing Conditions
1000B (08H)	When any of P0A ₀ -P0A ₃ and P0B ₀ -P0B ₃ pins goes low
Others	Inhibited

8.4 STOP Instruction Execution Conditions

The STOP instruction can be executed, only under special conditions, as shown in Table 8-5, to prevent the program from hangup.

If the conditions in Table 8-5 are not satisfied, the STOP instruction is treated as an NOP instruction.

Table 8-5 STOP Instruction Execution Conditions

Operand Value	Execution Conditions
1000B (08H)	High level input for all P0A ₀ -P0A ₃ and P0B ₀ -P0B ₃ pins
Others	Inhibited

8.5 Releasing Standby Mode

Operations for releasing the STOP and HALT modes will be as shown in Fig. 8-1.

Fig. 8-1 Operations After Standby Mode Release

(a) Releasing STOP mode by interrupt

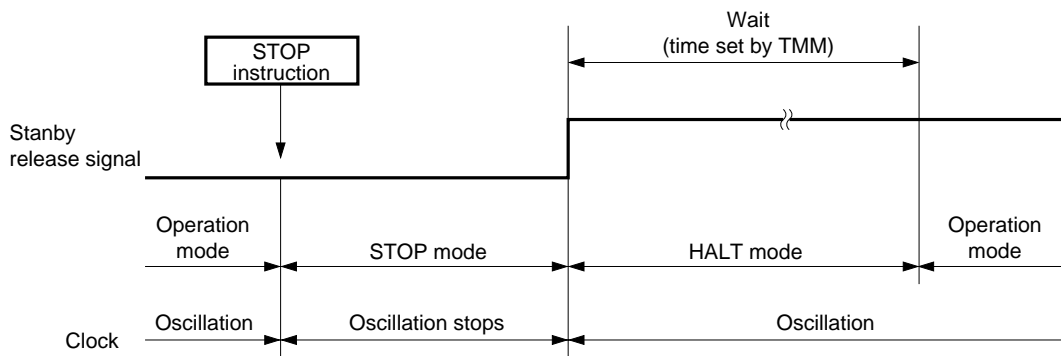

(b) Releasing HALT mode by interrupt

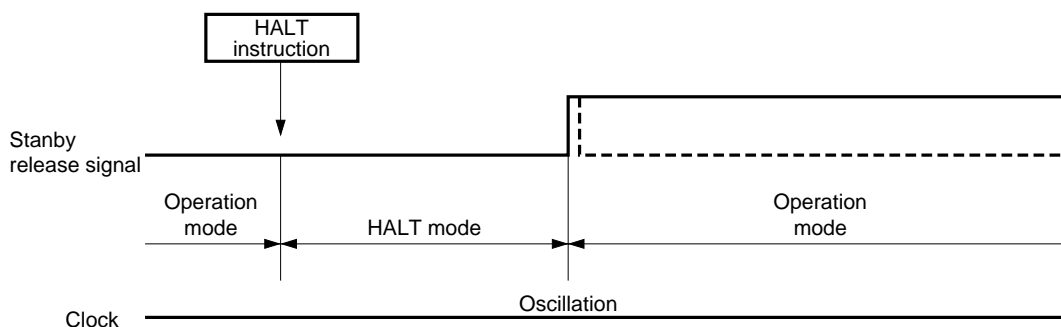

Remark: The dotted line indicates the operation to be performed when the interrupt request, releasing the standby mode, has been accepted.

9. RESET

9.1 Reset by Reset Signal Input

When a low-level signal more than 50 μ s is input to the $\overline{\text{RESET}}$ pin, μ PD17215 is reset.

When the system is reset, the oscillator circuit remains in the HALT mode and then enters an operation mode, like when the STOP mode has been released. The wait time, after the reset signal has been removed, is 16.384 ms ($f_x = 4$ MHz).

On power application, input the reset signal at least once because the internal circuitry operations are not stable. When μ PD17215 is reset, the following initialization takes place:

- (1) Program counter is reset to 0.
- (2) Flags in the register file are initialized to their default values (for the default values, refer to Fig. 11-1 Register Files).
- (3) The default value (0320H) is written to the data buffer (DBF).
- (4) The hardware peripherals are initialized.
- (5) The system clock (f_x) stops oscillation.

When the $\overline{\text{RESET}}$ pin is made high, the system clock starts oscillating, and the program execution starts from address 0H about 16 ms (at 4 MHz) later.

Fig. 9-1 Reset Operation by $\overline{\text{RESET}}$ Input

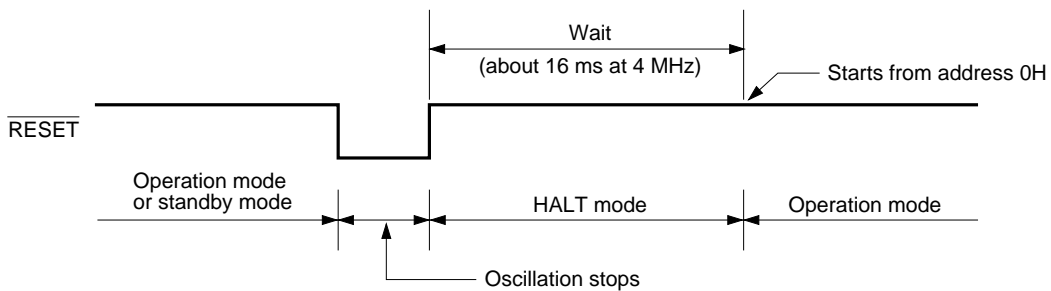

9.2 Reset by Watchdog Timer (Connect $\overline{\text{RESET}}$ and $\overline{\text{WDOUT}}$ pins)

When the watchdog timer operates during program execution, a low level is output to the $\overline{\text{WDOUT}}$ pin, and the program counter is reset to 0.

If the watchdog timer is not reset for a fixed period of time, the program can be restarted from address 0H.

Program so that the watchdog timer is reset at intervals of within 340 ms (at $f_x = 4$ MHz) (set the WDTRES flag).

9.3 Reset by Stack Pointer (Connect $\overline{\text{RESET}}$ and $\overline{\text{WDOUT}}$ pins)

When the value of the stack pointer reaches 6H or 7H during program execution, a low level is output to the $\overline{\text{WDOUT}}$ pin, and the program counter is reset to 0.

If the nesting level of the interrupt or subroutine call exceeds 5 (stack over flow), or if the return instruction is executed without correspondence between CALL and return (RET) instructions established, then regardless of a stack level of 0 (stack underflow), the program can be restarted from address 0H.

Table 9-1 Status of Each Hardware After Reset

Hardware		$\overline{\text{RESET}}$ Input During Standby Mode	$\overline{\text{RESET}}$ Input During Operation
Program Counter (PC)		0000H	0000H
Port	Input/output	Input	Input
	Output latch	0	0
Data Memory (RAM)	General-purpose data memory (Except DBF, port register)	Retains previous status	Undefined
	DBF	0320H	0320H
	System register (SYSREG)	0	0
	WR	Retains previous status	Undefined
Control Register		Refer to Fig. 11-1 Register Files	
8-bit Timer	Counter (TMC)	00H	00H
	Modulo register (TMM)	FFH	FFH
Remote Controller Carrier Generator	NRZ high level period setting modulo register (NRZHTMM)	Retains previous status	Undefined
	NRZ low level period setting modulo register (NRZLTMM)		
Basic Interval Timer/Watchdog Timer Counter		00H	00H

10. LOW-VOLTAGE DETECTOR CIRCUIT (CONNECT $\overline{\text{RESET}}$ AND $\overline{\text{WDOUT}}$ PINS)

The low-voltage detector circuit outputs a low level from the $\overline{\text{WDOUT}}$ pin for initialization (reset) to prevent program hang-up that may take place when the batteries are replaced, if the circuit detects a low voltage.

A drop in the supply voltage is detected if the status of $T_A = -10$ to $+85^\circ\text{C}$, $V_{DD} = 0.8$ to 2.2 V lasts for 1 ms or longer. Note, however, that 1 ms is the guaranteed value and that the microcontroller may be reset even if the above low-voltage condition lasts for less than 1 ms.

Although the voltage at which the the reset function is effected ranges from 0.8 to 2.2 V, the program counter is prevented from hang-up even if the supply voltage drops until the reset function is effected, if the instruction execution time is from 8 to 32 μs. Note that some oscillators stop oscillating before the reset function is effected.

The low-voltage detector circuit can be set arbitrarily by the mask option.

Caution: Connect a diode and a capacitor to the $\overline{\text{RESET}}$ pin as shown below to stabilize the operation.

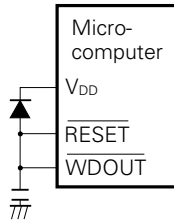

Remark: In this figure, the $\overline{\text{RESET}}$ pin is connected to a pull-up resistor by the mask option.

11. ASSEMBLER RESERVED WORDS

11.1 Mask Option Directives

When developing the μPD17215 program, mask options must be specified by using mask option directives in the program.

The $\overline{\text{RESET}}$ pin for μPD17215 requires a mask option to be specified.

11.1.1 OPTION and ENDOP directives

That portion of the program enclosed by the OPTION and ENDOP directives is called a mask option definition block. This block is described in the following format:

Description:

<u>Symbol</u>	<u>Mnemonic</u>	<u>Operand</u>	<u>Comment</u>
[Label:]	OPTION		[:Comment]
	⋮		
	ENDOP		

11.1.2 Mask option definition directives

Table 19-1 lists the directives that can be used in the mask option definition block.

Here is an example of mask option definition:

Description format:

<u>Symbol field</u>	<u>Mnemonic field</u>	<u>Operand field</u>	<u>Comment field</u>
	OPTION		
	OPTRES	PULLUP	; RESET pin has pull-up resistors.
	OPTPOC	USEPOC	; Internal low-voltage detector circuit
	ENDOP		

Table 11-1 Mask Option Definition Directives

Name	Directive	Operands	1st Operand	2nd Operand	3rd Operand	4th Operand
RESET	OPTRES	1	Mask option of RESET			
			PULLUP (w/pull-up resistor) OPEN (w/o pull-up resistor)			
POC	OPTPOC	1	USEPOC (low-voltage detector circuit provided)			
			NOUSEPOC (low-voltage detector circuit not provided)			

11.2 Reserved Symbols

The symbols defined by the μPD17215 device file are listed in Table 11-2.

The defined symbols are the following register file names, port names, and peripheral hardware names.

11.2.1 Register file

The names of the symbols assigned to the register file are defined. These registers are accessed by the PEEK and POKE instructions through the window register (WR). Fig. 11-1 shows the register file.

11.2.2 Registers and ports on data memory

The names of the registers assigned at addresses 00H through 7FH on the data memory and the names of ports assigned to address 70H and those that follow, and system register names are defined. Fig. 11-2 shows the data memory configuration.

11.2.3 Peripheral hardware

The names of peripheral hardware accessed by the GET and PUT instructions are defined. Table 11-3 shows the peripheral hardware.

Table 11-2 Reserved Symbols (1/2)

Symbol Name	Attribute	Value	R/W	Description
DBF3	MEM	0.0CH	R/W	Bits 15-12 of data buffer
DBF2	MEM	0.0DH	R/W	Bits 11-8 of data buffer
DBF1	MEM	0.0EH	R/W	Bits 7-4 of data buffer
DBF0	MEM	0.0FH	R/W	Bits 3-0 of data buffer
AR3	MEM	0.74H	R	Bits 15-12 of address register
AR2	MEM	0.75H	R/W	Bits 11-8 of address register
AR1	MEM	0.76H	R/W	Bits 7-4 of address register
AR0	MEM	0.77H	R/W	Bits 3-0 of address register
WR	MEM	0.78H	R/W	Window register
BANK	MEM	0.79H	R	Bank register
IXH	MEM	0.7AH	R	Bits 11-8 of index register
MPH	MEM	0.7AH	R	Bits 7-4 of memory pointer
MPE	FLG	0.7AH.3	R/W	Memory pointer enable flag
IXM	MEM	0.7BH	R/W	Bits 7-4 of index register
MPL	MEM	0.7BH	R/W	Bits 3-0 of memory pointer
IXL	MEM	0.7CH	R/W	Bits 3-0 of index register
RPH	MEM	0.7DH	R	Bits 7-4 of register pointer
RPL	MEM	0.7EH	R/W	Bits 3-0 of register pointer
PSW	MEM	0.7FH	R/W	Program status word
BCD	FLG	0.7EH.0	R/W	BCD flag
CMP	FLG	0.7FH.3	R/W	Compare flag
CY	FLG	0.7FH.2	R/W	Carry flag
Z	FLG	0.7FH.1	R/W	Zero flag
IXE	FLG	0.7FH.0	R/W	Index register enable flag
P0A0	FLG	0.70H.0	R/W	Bit 0 of port 0A
P0A1	FLG	0.70H.1	R/W	Bit 1 of port 0A
P0A2	FLG	0.70H.2	R/W	Bit 2 of port 0A
P0A3	FLG	0.70H.3	R/W	Bit 3 of port 0A
P0B0	FLG	0.71H.0	R/W	Bit 0 of port 0B
P0B1	FLG	0.71H.1	R/W	Bit 1 of port 0B
P0B2	FLG	0.71H.2	R/W	Bit 2 of port 0B
P0B3	FLG	0.71H.3	R/W	Bit 3 of port 0B
P0C0	FLG	0.72H.0	R/W	Bit 0 of port 0C
P0C1	FLG	0.72H.1	R/W	Bit 1 of port 0C
P0C2	FLG	0.72H.2	R/W	Bit 2 of port 0C
P0C3	FLG	0.72H.3	R/W	Bit 3 of port 0C
P0D0	FLG	0.73H.0	R/W	Bit 0 of port 0D
P0D1	FLG	0.73H.1	R/W	Bit 1 of port 0D
P0D2	FLG	0.73H.2	R/W	Bit 2 of port 0D
P0D3	FLG	0.73H.3	R/W	Bit 3 of port 0D

Table 11-2 Reserved Symbols (2/2)

Symbol Name	Attribute	Value	R/W	Description
P0E0	FLG	0.6FH.0	R/W	Bit 0, port 0E
P0E1	FLG	0.6FH.1	R/W	Bit 1, port 0E
P0E2	FLG	0.6FH.2	R/W	Bit 2, port 0E
P0E3	FLG	0.6FH.3	R/W	Bit 3, port 0E
SP	MEM	0.81H	R/W	Stack pointer
SYSCK	FLG	0.82H.0	R/W	Selects system clock
WDTRES	FLG	0.83H.3	R/W	Resets watchdog timer
BTMCK	FLG	0.83H.2	R/W	Selects basic interval timer mode
BTMRES	FLG	0.83H.1	R/W	Resets basic interval timer mode
INT	FLG	0.8FH.0	R	INT pin status
NRZBF	FLG	0.91H.0	R/W	NRZ buffer data
NRZ	FLG	0.92H.0	R/W	NRZ data
P0EBPU0	FLG	0.97H.0	R/W	Pull-up resistor setting flag for P0E ₀
P0EBPU1	FLG	0.97H.1	R/W	Pull-up resistor setting flag for P0E ₁
P0EBPU2	FLG	0.97H.2	R/W	Pull-up resistor setting flag for P0E ₂
P0EBPU3	FLG	0.97H.3	R/W	Pull-up resistor setting flag for P0E ₃
IEG	FLG	0.9FH.0	R/W	Selects interrupt edge for INT pin
P0EBIO0	FLG	0.0A7H.0	R/W	I/O setting flag, P0E ₀
P0EBIO1	FLG	0.0A7H.1	R/W	I/O setting flag, P0E ₁
P0EBIO2	FLG	0.0A7H.2	R/W	I/O setting flag, P0E ₂
P0EBIO3	FLG	0.0A7H.3	R/W	I/O setting flag, P0E ₃
IPBTM	FLG	0.0AFH.2	R/W	Interrupt enable flag of basic interval timer
IP	FLG	0.0AFH.1	R/W	INT interrupt enable flag
IPTM	FLG	0.0AFH.0	R/W	8-bit timer interrupt enable flag
TMEN	FLG	0.0B3H.3	R/W	8-bit timer count enable flag
TMRES	FLG	0.0B3H.2	R/W	8-bit timer reset flag
TMCK1	FLG	0.0B3H.1	R/W	Selects clock source for 8-bit timer
TMCK0	FLG	0.0B3H.0	R/W	Selects clock source for 8-bit timer
IRQBTM	FLG	0.0BDH.0	R/W	Basic interval timer interrupt request flag
IRQ	FLG	0.0BEH.0	R/W	INT interrupt request flag
IRQTM	FLG	0.0BFH.0	R/W	8-bit timer interrupt request flag
TMC	DAT	05H	R	8-bit counter
TMM	DAT	06H	W	8-bit modulo register
NRZLTMM	DAT	03H	R/W	NRZ low level period setting modulo register
NRZHTMM	DAT	04H	R/W	NRZ high level period setting modulo register
AR	DAT	40H	R/W	Address register

Fig. 11-1 Register Files (1/2)

Column Address \ Row Address		0	1	2	3	4	5	6	7
		*	*	*	*	*	*	*	*
0	Bit 3			0	0	0	WDTRES	0	
	Bit 2			1	0	0	BTMCK	0	
	Bit 1		SP	0	0	0	BTMRES	0	
	Bit 0			1	SYSCK	0	0	0	
1	Bit 3		0	0	0	0			P0EBPU3: 0
	Bit 2		0	0	0	0			P0EBPU2: 0
	Bit 1		0	0	0	0			P0EBPU1: 0
	Bit 0		NRZBF	0	NRZ	0			P0EBPU0: 0
2	Bit 3								P0EBIO3: 0
	Bit 2								P0EBIO2: 0
	Bit 1								P0EBIO1: 0
	Bit 0								P0EBIO0: 0
3	Bit 3				TMEN	1			
	Bit 2				TMRES	0			
	Bit 1				TMCK1	0			
	Bit 0				TMCK0	0			

*: On reset

Fig. 11-2 Data Memory Configuration

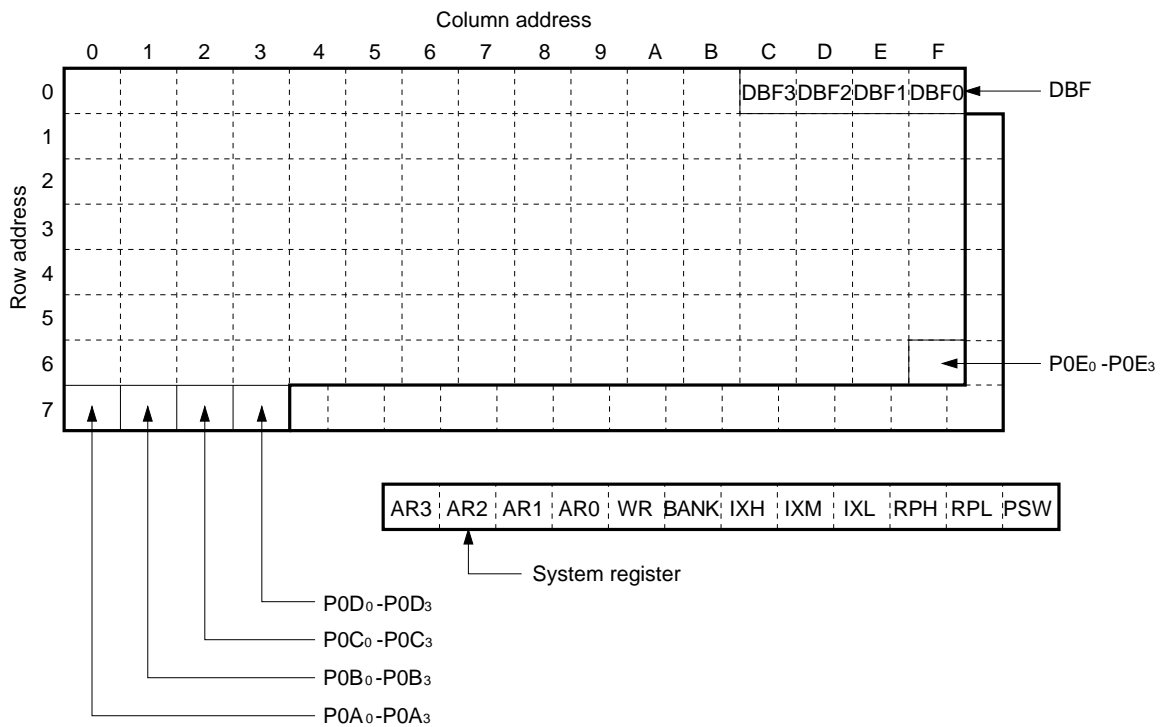

Fig. 11-1 Register Files (2/2)

Column Address / Row Address		8	9	A	B	C	D	E	F
		*	*	*	*	*	*	*	*
0	Bit 3								0 0
	Bit 2								0 0
	Bit 1								0 0
	Bit 0								INT P
1	Bit 3								0 0
	Bit 2								0 0
	Bit 1								0 0
	Bit 0								IEG 0
2	Bit 3								0 0
	Bit 2								IPBTM 0
	Bit 1								IP 0
	Bit 0								IPTM 0
3	Bit 3						0 0	0 0	0 0
	Bit 2						0 0	0 0	0 0
	Bit 1						0 0	0 0	0 0
	Bit 0						IRQBTM: 0	IRQ 0	IRQTM: 1

*: On reset

P: When INT pin is high level, 1 or when INT pin is low level, 0.

Table 11-3 Peripheral Hardware

Name	Address	Valid Bit	Description
TMC	05H	8	8-bit timer count register
TMM	06H	8	8-bit timer modulo register
NRZLTMM	03H	8	Low level period setting modulo register for remote controller carrier generation
NRZHTMM	04H	8	High level period setting modulo register for remote controller carrier generation
AR	40H	16	Address register

12. INSTRUCTION SET

12.1 Instruction Set Outline

b ₁₄ -b ₁₁		b ₁₅		0		1	
		BIN.	HEX.				
0 0 0 0	0	ADD	r, m	ADD	m, #n4		
0 0 0 1	1	SUB	r, m	SUB	m, #n4		
0 0 1 0	2	ADDC	r, m	ADDC	m, #n4		
0 0 1 1	3	SUBC	r, m	SUBC	m, #n4		
0 1 0 0	4	AND	r, m	AND	m, #n4		
0 1 0 1	5	XOR	r, m	XOR	m, #n4		
0 1 1 0	6	OR	r, m	OR	m, #n4		
0 1 1 1	7	INC	AR				
		INC	IX				
		MOVT	DBF, @AR				
		BR	@AR				
		CALL	@AR				
		RET					
		RETSK					
		EI					
		DI					
		RETI					
		PUSH	AR				
		POP	AR				
		GET	DBF, p				
		PUT	p, DBF				
		PEEK	WR, rf				
POKE	rf, WR						
RORC	r						
STOP	s						
HALT	h						
NOP							
1 0 0 0	8	LD	r, m	ST	m, r		
1 0 0 1	9	SKE	m, #n4	SKGE	m, #n4		
1 0 1 0	A	MOV	@r, m	MOV	m, @r		
1 0 1 1	B	SKNE	m, #n4	SKLT	m, #n4		
1 1 0 0	C	BR	addr (Page 0)	CALL	addr		
1 1 0 1	D	BR	addr (Page 1)	MOV	m, #n4		
1 1 1 0	E	BR	addr (Page 2)	SKT	m, #n		
1 1 1 1	F	BR	addr (Page 3)	SKF	m, #n		

12.2 Legend

AR	: Address register
ASR	: Address stack register specified by stack pointer
addr	: Program memory address (lower 11 bits)
BANK	: Bank register
CMP	: Compare register
CY	: Carry flag
DBF	: Data buffer
h	: Halt releasing condition
INTEF	: Interrupt enable flag
INTR	: Register automatically saved to stack in case of interrupt
INTSK	: Interrupt stack register
IX	: Index register
MP	: Data memory row address pointer
MPE	: Memory pointer enable flag
m	: Data memory address specified by m _R , m _C
m _R	: Data memory row address (high)
m _C	: Data memory column address (low)
n	: Bit position (4 bits)
n4	: Immediate data (4 bits)
PAGE	: Page (bit 11 and 12 of program counter)
PC	: Program counter
p	: Peripheral address
p _H	: Peripheral address (higher 3 bits)
p _L	: Peripheral address (lower 4 bits)
r	: General register column address
rf	: Register file address
rf _R	: Register file address (higher 3 bits)
rf _C	: Register file address (lower 4 bits)
SP	: Stack pointer
s	: Stop releasing condition
WR	: Window register
(x)	: Contents addressed by x

12.3 List of Instruction Sets

Group	Mnemonic	Operand	Operation	Instruction Code			
				OP Code	Operand		
Addition	ADD	r, m	$(r) \leftarrow (r) + (m)$	00000	m _R	mc	r
		m, #n4	$(m) \leftarrow (m) + n4$	10000	m _R	mc	n4
	ADDC	r, m	$(r) \leftarrow (r) + (m) + CY$	00010	m _R	mc	r
		m, #n4	$(m) \leftarrow (m) + n4 + CY$	10010	m _R	mc	n4
	INC	AR	$AR \leftarrow AR + 1$	00111	000	1001	0000
		IX	$IX \leftarrow IX + 1$	00111	000	1000	0000
Subtraction	SUB	r, m	$(r) \leftarrow (r) - (m)$	00001	m _R	mc	r
		m, #n4	$(m) \leftarrow (m) - n4$	10001	m _R	mc	n4
	SUBC	r, m	$(r) \leftarrow (r) - (m) - CY$	00011	m _R	mc	r
		m, #n4	$(m) \leftarrow (m) - n4 - CY$	10011	m _R	mc	n4
Logical	OR	r, m	$(r) \leftarrow (r) \vee (m)$	00110	m _R	mc	r
		m, #n4	$(m) \leftarrow (m) \vee n4$	10110	m _R	mc	n4
	AND	r, m	$(r) \leftarrow (r) \wedge (m)$	00100	m _R	mc	r
		m, #n4	$(m) \leftarrow (m) \wedge n4$	10100	m _R	mc	n4
	XOR	r, m	$(r) \leftarrow (r) \nabla (m)$	00101	m _R	mc	r
		m, #n4	$(m) \leftarrow (m) \nabla n4$	10101	m _R	mc	n4
Judge	SKT	m, #n	$CMP \leftarrow 0$, if $(m) \wedge n = n$, then skip	11110	m _R	mc	n
	SKF	m, #n	$CMP \leftarrow 0$, if $(m) \wedge n = 0$, then skip	11111	m _R	mc	n
Compare	SKE	m, #n4	$(m)-n4$, skip if zero	01001	m _R	mc	n4
	SKNE	m, #n4	$(m)-n4$, skip if not zero	01011	m _R	mc	n4
	SKGE	m, #n4	$(m)-n4$, skip if not borrow	11001	m _R	mc	n4
	SKLT	m, #n4	$(m)-n4$, skip if borrow	11011	m _R	mc	n4
Rotate	RORC	r	$\leftarrow CY \rightarrow (r)_{b3} \rightarrow (r)_{b2} \rightarrow (r)_{b1} \rightarrow (r)_{b0}$	00111	000	0111	r
Transfer	LD	r, m	$(r) \leftarrow (m)$	01000	m _R	mc	r
	ST	m, r	$(m) \leftarrow (r)$	11000	m _R	mc	r
	MOV	@r, m	if MPE = 1 : $(MP, (r)) \leftarrow (m)$ if MPE = 0 : $(BANK, m_R, (r)) \leftarrow (m)$	01010	m _R	mc	r
		m, @r	if MPE = 1 : $(m) \leftarrow (MP, (r))$ if MPE = 0 : $(m) \leftarrow (BANK, m_R, (r))$	11010	m _R	mc	r
		m, #n4	$(m) \leftarrow n4$	11101	m _R	mc	n4
	MOVT	DBF, @AR	$SP \leftarrow SP - 1, ASR \leftarrow PC, PC \leftarrow AR$ $DBF \leftarrow (PC), PC \leftarrow ASR, SP \leftarrow SP + 1$	00111	000	0001	0000

Group	Mnemonic	Operand	Operation	Instruction Code			
				OP Code	Operand		
Transfer	PUSH	AR	$SP \leftarrow SP - 1, ASR \leftarrow AR$	00111	000	1101	0000
	POP	AR	$AR \leftarrow ASR, SP \leftarrow SP + 1$	00111	000	1100	0000
	PEEK	WR, rf	$WR \leftarrow (rf)$	00111	rf _R	0011	rf _C
	POKE	rf, WR	$(rf) \leftarrow WR$	00111	rf _R	0010	rf _C
	GET	DBF, p	$(DBF) \leftarrow (p)$	00111	p _H	1011	p _L
	PUT	p, DBF	$(p) \leftarrow (DBF)$	00111	p _H	1010	p _L
Branch	BR	addr	μPD17215	$PC_{10-0} \leftarrow addr$	01100	addr	
			μPD17216	$PC_{10-0} \leftarrow addr, PAGE \leftarrow 0$	01100		
				$PC_{10-0} \leftarrow addr, PAGE \leftarrow 1$	01101		
			μPD17217	$PC_{10-0} \leftarrow addr, PAGE \leftarrow 0$	01100		
				$PC_{10-0} \leftarrow addr, PAGE \leftarrow 1$	01101		
				$PC_{10-0} \leftarrow addr, PAGE \leftarrow 2$	01110		
			μPD17218	$PC_{10-0} \leftarrow addr, PAGE \leftarrow 0$	01100		
				$PC_{10-0} \leftarrow addr, PAGE \leftarrow 1$	01101		
				$PC_{10-0} \leftarrow addr, PAGE \leftarrow 2$	01110		
		$PC_{10-0} \leftarrow addr, PAGE \leftarrow 3$		01111			
@AR	$PC \leftarrow AR$	00111	000	0100	0000		
Sub-routine	CALL	addr	$SP \leftarrow SP - 1, ASR \leftarrow PC, PC_{10-0} \leftarrow addr, PAGE \leftarrow 0$	11100		addr	
		@AR	$SP \leftarrow SP - 1, ASR \leftarrow PC, PC \leftarrow AR$	00111	000	0101	0000
	RET		$PC \leftarrow ASR, SP \leftarrow SP + 1$	00111	000	1110	0000
	RETSK		$PC \leftarrow ASR, SP \leftarrow SP + 1$ and skip	00111	001	1110	0000
	RETI		$PC \leftarrow ASR, INTR \leftarrow INTSK, SP \leftarrow SP + 1$	00111	100	1110	0000
Interrupt	EI		$INTEF \leftarrow 1$	00111	000	1111	0000
	DI		$INTEF \leftarrow 0$	00111	001	1111	0000
Other	STOP	s	STOP	00111	010	1111	s
	HALT	h	HALT	00111	011	1111	h
	NOP		No operation	00111	100	1111	0000

12.4 Assembler (AS17K) Built-In Macro Instruction

Legend

flag n: FLG type symbol

< >: Contents in < > can be omitted

	Mnemonic	Operand	Operation	n
Built-in macro	SKTn	flag 1, ...flag n	if (flag 1) to (flag n) = all "1", then skip	1 ≤ n ≤ 4
	SKFn	flag 1, ...flag n	if (flag 1) to (flag n) = all "0", then skip	1 ≤ n ≤ 4
	SETn	flag 1, ...flag n	(flag 1) to (flag n) ← 1	1 ≤ n ≤ 4
	CLRn	flag 1, ...flag n	(flag 1) to (flag n) ← 0	1 ≤ n ≤ 4
	NOTn	flag 1, ...flag n	if (flag n) = "0", then (flag n) ← 1 if (flag n) = "1", then (flag n) ← 0	1 ≤ n ≤ 4
	INITFLG	<NOT> flag 1, ...<<NOT> flag n>	if description = NOT flag n, then (flag n) ← 0 if description = flag n, then (flag n) ← 1	1 ≤ n ≤ 4
	BANKn		(BANK) ← n	n = 0, 1

13. ELECTRICAL SPECIFICATIONS

Absolute Maximum Ratings (T_A = 25°C)

Item	Symbol	Conditions	Ratings	Unit	
Supply Voltage	V _{DD}		-0.3 to +7.0	V	
Input Voltage	V _I		-0.3 to V _{DD} +0.3	V	
Output Voltage	V _O		-0.3 to V _{DD} +0.3	V	
High-Level Output Current*	I _{OH}	REM pin	Peak value	-36.0	mA
			Effective value	-24.0	mA
		1 pin (P0E pin)	Peak value	-7.5	mA
			Effective value	-5.0	mA
		Total of P0E pins	Peak value	-22.5	mA
			Effective value	-15.0	mA
Low-Level Output Current*	I _{OL}	1 pin (P0C, P0D, P0E, REM or WDO _{UT} pin)	Peak value	7.5	mA
			Effective value	5.0	mA
		Total of P0C, P0D, WDO _{UT} pins	Peak value	22.5	mA
			Effective value	15.0	mA
		Total of P0E pins	Peak value	30.0	mA
			Effective value	20.0	mA
Operating Ambient Temperature	T _A		-40 to +85	°C	
Storage Temperature	T _{stg}		-65 to +150	°C	
Power Dissipation	P _d	T _A = 85 °C	180	mW	

*: Calculate effective value by this expression:

$$[\text{Effective value}] = [\text{Peak value}] \times \sqrt{\text{Duty}}$$

Caution: Even if one of the parameters exceeds its absolute maximum rating even momentarily, the quality of the product may be degraded. The absolute maximum rating therefore specifies the upper or lower limit of the value at which the product can be used without physical damages. Be sure not to exceed or fall below this value when using the product.

Recommended Operating Ranges ($V_{DD} = 2.0$ to 5.5 V, $T_A = -40$ to $+85^\circ\text{C}$)

Item	Symbol	Conditions		MIN.	TYP.	MAX.	Unit
Supply Voltage	V_{DD1}	$f_x = 1$ MHz	High-speed mode (Instruction execution time: $16 \mu\text{s}$)	2.0	3.0	5.5	V
	V_{DD2}	$f_x = 4$ MHz	Ordinary mode (Instruction execution time: $8 \mu\text{s}$)				
	V_{DD3}		High-speed mode (Instruction execution time: $4 \mu\text{s}$)				
	V_{DD4}	$f_x = 8$ MHz	High-speed mode (Instruction execution time: $2 \mu\text{s}$)	3.5	5.0	5.5	
Oscillation Frequency	f_x			1.0	4.0	8.0	MHz
Operating Temperature	T_a			-40	+25	+85	$^\circ\text{C}$
Low-Voltage Detector Circuit* (Mask Option)	T_{CY}	$T_a = -10$ to $+85^\circ\text{C}$		8		32	μs

*: Reset if the status of $V_{DD} = 0.8$ to 2.2 V lasts for 1 ms or longer. Program hang-up does not occur even if the voltage drops, until the reset function is effected (when the RESET pin and WDOOUT pin are connected). Some oscillators stop oscillating before the reset function is effected.

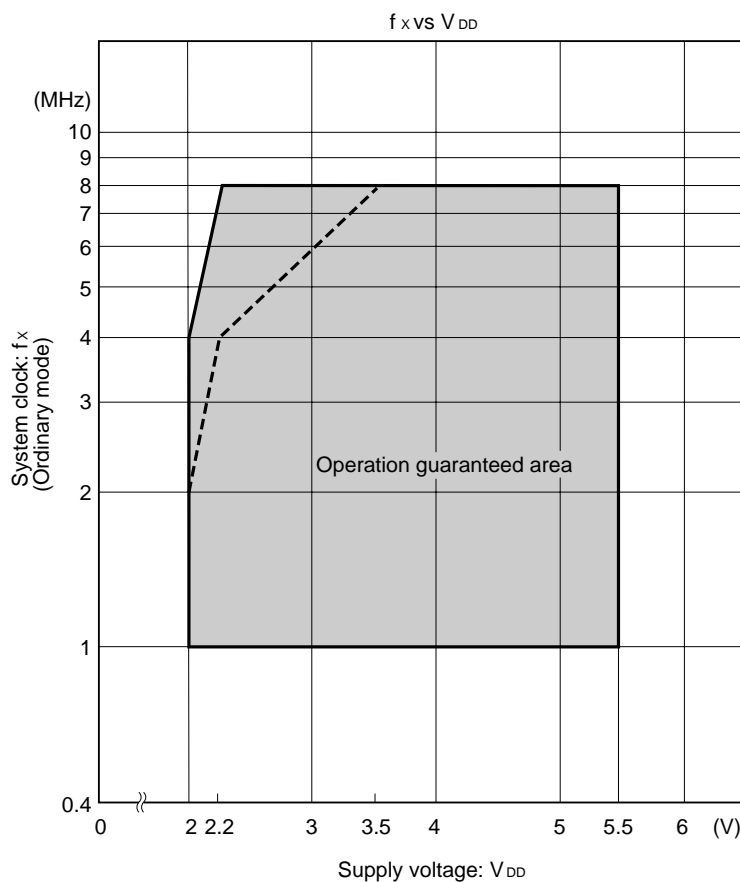

Remark: The region indicated by the broken line in the above figure is the guaranteed operating range in the high-speed mode.

System Clock Oscillator Circuit Characteristics ($T_A = -40$ to $+85^\circ\text{C}$, $V_{DD} = 2.0$ to 5.5 V)

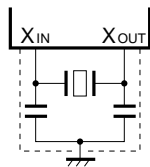
Resonator	Recommended Constants	Item	Conditions	MIN.	TYP.	MAX.	Unit
Ceramic		Oscillation frequency (f_x)*1		1.0	4.0	8.0	MHz
		Oscillation stabilization time*2	After V_{DD} reached MIN. in oscillation voltage range			4	ms

* 1: The oscillation frequency only indicates the oscillator characteristics.

2: The oscillation stabilization time is necessary for oscillation to be stabilized, after V_{DD} application or STOP mode release.

Caution: To use a system clock oscillator circuit, perform the wiring in the area enclosed by the dotted line in the above figure as follows, to avoid adverse wiring capacitance influences:

- Keep wiring length as short as possible.
- Do not cross a signal line with some other signal lines. Do not route the wiring in the vicinity of lines through which a large current flows.
- Always keep the oscillator circuit capacitor ground at the same potential as GND. Do not ground the capacitor to a ground pattern, through which a large current flows.
- Do not extract signals from the oscillator circuit.

External circuit example

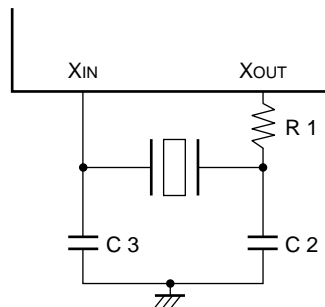

Ceramic resonators

Manufacturer	Product Name	Recommended Circuit Constants			Oscillation Voltage Range	
		C1 (pF)	C2 (pF)	R1 (kΩ)	MIN. (V)	MAX. (V)
Murata Mfg, Co., Ltd.	CSB1000J	100	100	4.7	2.0	5.5
	CSA2.00MG	30	30	–	2.0	5.5
	CSA4.00MG	30	30	–	2.0	5.5
	CSA6.00MG	30	30	–	2.0	5.5
	CSA8.00MTZ	30	30	–	2.1	5.5
	CST2.00MG	–	–	–	2.0	5.5
	CST4.00MGW	–	–	–	2.0	5.5
	CST6.00MGW	–	–	–	2.0	5.5
	CST8.00MTW	–	–	–	2.1	5.5
Kyocera Corp.	KBR-1000Y/F	100	100	–	2.0	5.5
	KBR-2.0MS	47	47	–	2.0	5.5
	KBR-4.0MSA	33	33	–	2.0	5.5
	KBR-4.0MKS/MWS	–	–	–	2.0	5.5
	KBR-6.0MSA	33	33	–	2.2	5.5
	KBR-6.0MKS/MWS	–	–	–	2.0	5.5
	KBR-8.0M	33	33	–	2.2	5.5
	PBRC2.00A	47	47	–	2.0	5.5
	PBRC3.58A	33	33	–	2.0	5.5
	PBRC4.00A	33	33	–	2.0	5.5
	PBRC6.00A	33	33	–	2.0	5.5
	PBRC8.00A	33	33	–	2.0	5.5
TDK Corp.	FCR2.0M3	33	33	–	2.0	5.5
	FCR2.0MC3	–	–	–	2.0	5.5
	FCR4.0M5	33	33	–	2.0	5.5
	FCR4.0MC5	–	–	–	2.0	5.5
	CCR4.0MC3	–	–	–	2.0	5.5
Matsushita Electronics Components Co., Ltd.	EFOEC2004A4	–	–	–	2.0	5.5
	EFOEC4004A4	–	–	–	2.0	5.5
	EFOEC6004A4	–	–	–	2.0	5.5
	EFOEC8004A4	–	–	–	2.0	5.5
	EFOEN2004A4	33	33	–	2.0	5.5
	EFOEN4004A4	33	33	–	2.0	5.5
	EFOEN6004A4	33	33	–	2.0	5.5
	EFOEN8004A4	33	33	–	2.0	5.5

DC Characteristics (V_{DD} = 2.0 to 5.5 V, T_A = -40 to +85°C)

Item	Symbol	Conditions		MIN.	TYP.	MAX.	Unit
High-Level Input Voltage	V _{IH1}	$\overline{\text{RESET}}$, INT pin		0.8V _{DD}		V _{DD}	V
	V _{IH2}	P0A, P0B		0.7V _{DD}		V _{DD}	V
	V _{IH3}	P0E	2.0 V ≤ V _{DD} < 3.0 V	V _{DD} -0.3		V _{DD}	V
	V _{IH4}	P0E	3.0 V ≤ V _{DD} ≤ 5.5 V	V _{DD} -0.5		V _{DD}	V
	V _{IH5}	X _{IN}		0.8V _{DD}		V _{DD}	V
Low-Level Input Voltage	V _{IL1}	$\overline{\text{RESET}}$, INT pin		0		0.2V _{DD}	V
	V _{IL2}	P0A, P0B		0		0.3V _{DD}	V
	V _{IL3}	P0E		0		0.35V _{DD}	V
	V _{IL4}	X _{IN}		0		0.2V _{DD}	V
High-Level Input Leakage Current	I _{LIH}	INT, $\overline{\text{RESET}}$, P0A, P0B, P0E	V _{IH} = V _{DD}			3.0	μA
Low-Level Input Leakage Current	I _{LIL1}	INT	V _{IL} = 0 V			-3.0	μA
	I _{LIL2}	P0E	V _{IL} = 0 V w/o pull-up resistor			-3.0	μA
High-Level Output Leakage Current	I _{LOH}	P0C, P0D, P0E, WDO _{UT}	V _{OH} = V _{DD}			3.0	μA
Low-Level Output Leakage Current	I _{LOL1}	$\overline{\text{WDOUT}}$	V _{OL} = 0 V			-3.0	μA
	I _{LOL2}	P0E	V _{OL} = 0 V w/o pull-up resistor			-3.0	μA
High-Level Input Current	I _{IH}	X _{IN}	V _{IH} = V _{DD}			20	μA
Low-Level Input Current	I _{IL}	X _{IN}	V _{IL} = 0 V			-20	μA
Internal Pull-Up Resistor	R _{U1}	$\overline{\text{RESET}}$, P0E	V _{DD} = 3 V ± 10%	25	50	100	kΩ
		$\overline{\text{RESET}}$, P0E	V _{DD} = 5 V ± 10%	25	50	100	kΩ
	R _{U2}	P0A, P0B	V _{DD} = 3 V ± 10%	100	200	400	kΩ
		P0A, P0B	V _{DD} = 5 V ± 10%	100	200	400	kΩ
★ High-Level Output Current	I _{OH}	REM	V _{OH} = 1.0 V, V _{DD} = 3 V	-6.0	-13.0		mA
★ High-Level Output Voltage	V _{OH}	P0E, REM	I _{OH} = -0.5 V mA	V _{DD} -0.3			V
★ Low-Level Output Voltage	V _{OL1}	P0C, P0D, REM, WDO _{UT}	I _{OL} = 0.5 mA			0.3	V
	V _{OL2}	P0E	I _{OL} = 1.5 mA			0.3	V
★ Low-Voltage Detector Circuit (Mask Option)	V _{DT1}			0.8	1.6	2.4	V
	V _{DT2}	T _A = -10 to +85°C		0.8	1.6	2.2	V
Data Retention Voltage	V _{DDR}	STOP mode		1.3			V

Item	Symbol	Conditions			MIN.	TYP.	MAX.	Unit
Supply Current	I _{DD1}	Operating mode (high-speed mode)	f _x = 8 MHz	V _{DD} = 5 V ± 10%		2	4	mA
	I _{DD2}				HALT mode	f _x = 8 MHz		0.9
	I _{DD3}	Operating mode (high-speed mode)	f _x = 4 MHz	V _{DD} = 5 V ± 10%		1.3	3.0	mA
				V _{DD} = 3 V ± 10%		0.5	1.0	mA
		Operating mode (ordinary mode)		V _{DD} = 5 V ± 10%		1.0	2.0	mA
				V _{DD} = 3 V ± 10%		0.4	0.8	mA
	I _{DD4}	HALT mode	f _x = 4 MHz	V _{DD} = 5 V ± 10%		0.8	1.8	mA
				V _{DD} = 3 V ± 10%		0.3	0.6	mA
				V _{DD} = 2 to 2.2 V		0.15	0.3	mA
	I _{DD5}	Operating mode (high-speed mode)	f _x = 1 MHz	V _{DD} = 3 V ± 10%		0.25	0.5	mA
				V _{DD} = 2 to 2.2 V		0.15	0.3	mA
	I _{DD6}	HALT mode	f _x = 1 MHz	V _{DD} = 3 V ± 10%		0.2	0.4	mA
				V _{DD} = 2 to 2.2 V		0.1	0.2	mA
	I _{DD7}	STOP mode (T _A = -40 to +85°C)		V _{DD} = 5 V ± 10%		1	30	μA
				V _{DD} = 3 V ± 10%		1	20	μA
				V _{DD} = 2 to 2.2 V		1	16	μA
	I _{DD8}	STOP mode (T _A = -20 to +70°C)		V _{DD} = 5 V ± 10%		1	20	μA
				V _{DD} = 3 V ± 10%		1	10	μA
V _{DD} = 2 to 2.2 V					1	8	μA	
I _{DD9}	STOP mode (T _A = 25°C)		V _{DD} = 5 V ± 10%		1	5	μA	
			V _{DD} = 3 V ± 10%		1	5	μA	
			V _{DD} = 2 to 2.2 V		1	5	μA	

AC Characteristics (V_{DD} = 2.0 to 5.5 V, T_A = -40 to +85°C)

Item	Symbol	Conditions	MIN.	TYP.	MAX.	Unit
CPU Clock Cycle Time* (Instruction Execution Time)	t _{cy1}	V _{DD} = 3.5 to 5.5 V	1.99		32.2	μs
	t _{cy2}	V _{DD} = 2.2 to 5.5 V	3.98		32.2	μs
	t _{cy3}		7.96		32.2	μs
INT High/Low Level Width	t _{IOH} , t _{IOL}	V _{DD} = 4.5 to 5.5 V	10			μs
			50			μs
RESET Low Level Width	t _{RSL}	V _{DD} = 4.5 to 5.5 V	10			μs
			50			μs

*: The CPU clock cycle time (instruction execution time) is determined by the oscillation frequency of the oscillator connected and SYSCK (RF: address 02H) of the register file.

The figure on the right shows the CPU clock cycle time t_{cy} vs. supply voltage V_{DD} characteristics (refer to 4. CLOCK GENERATOR CIRCUIT).

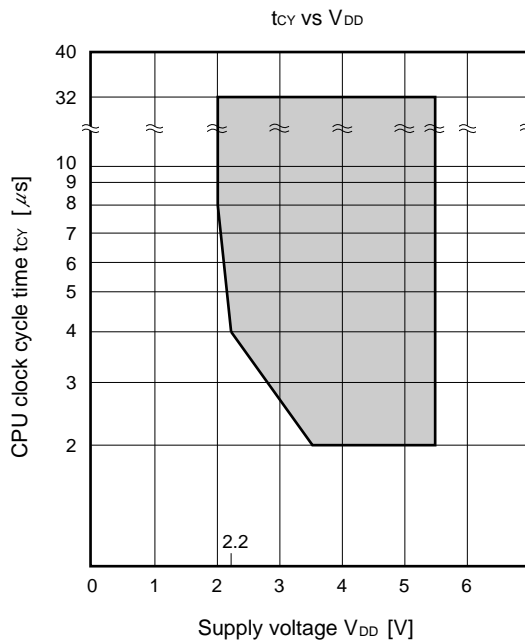

14. CHARACTERISTIC WAVEFORMS (REFERENCE VALUE)

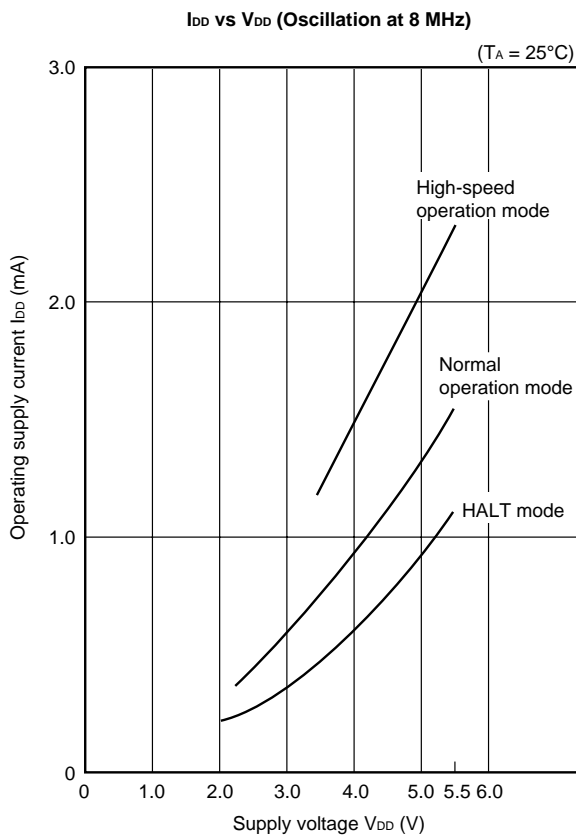
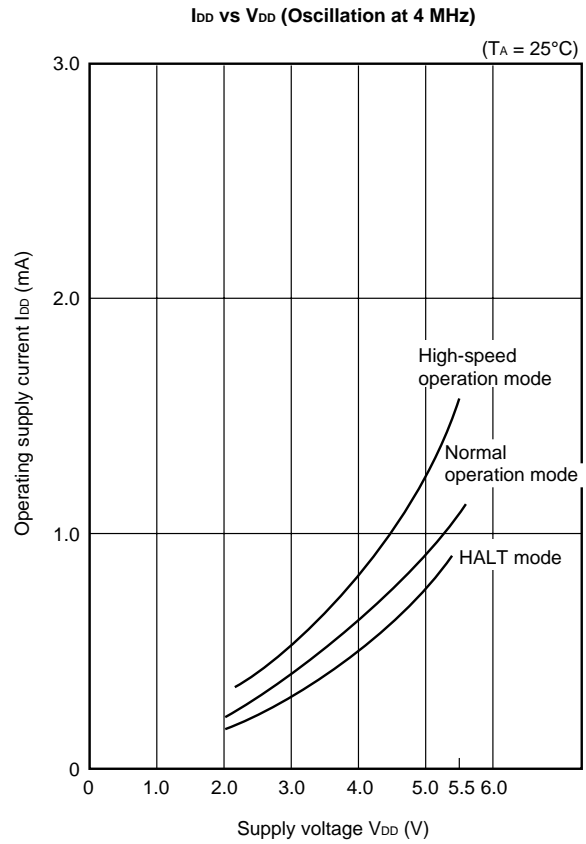
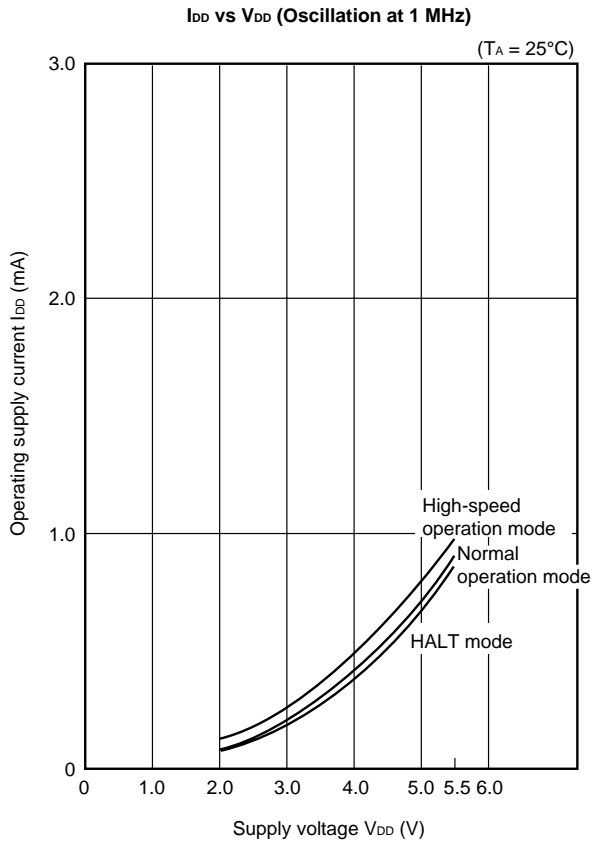

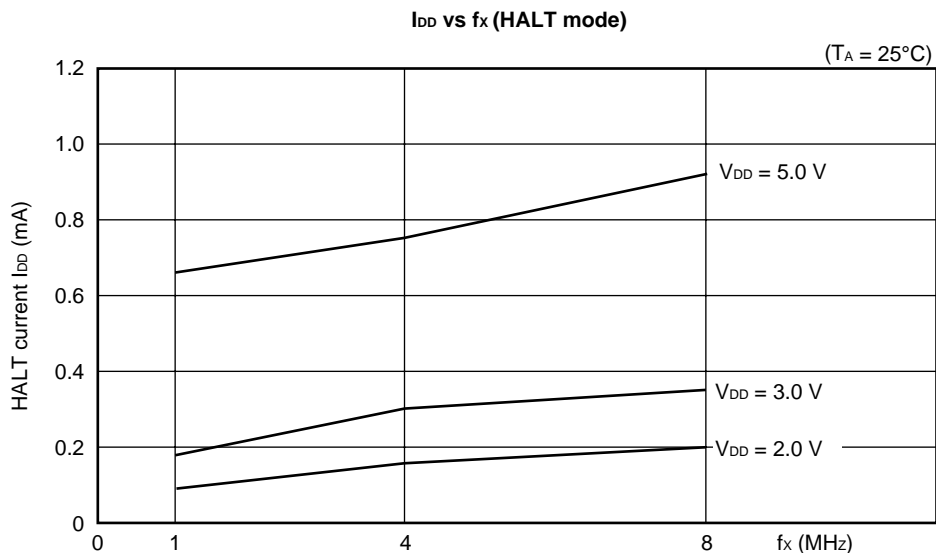
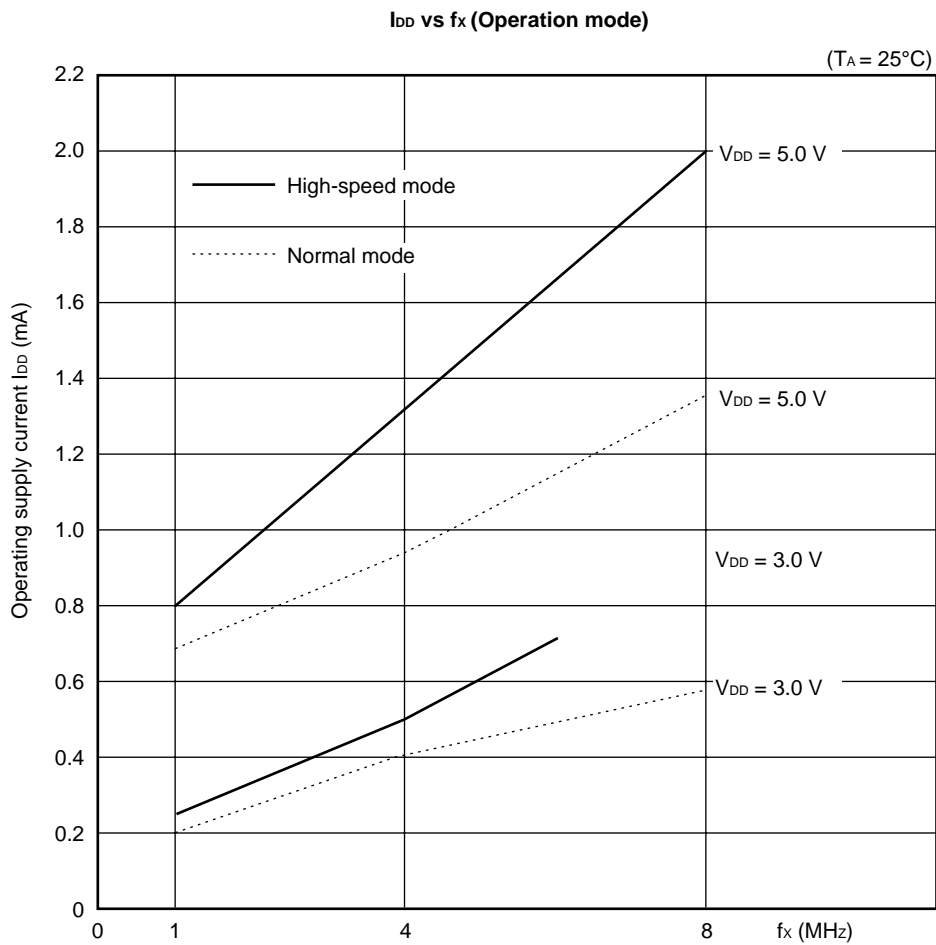

I_{OH} (REM) vs $V_{DD}-V_{OH}$

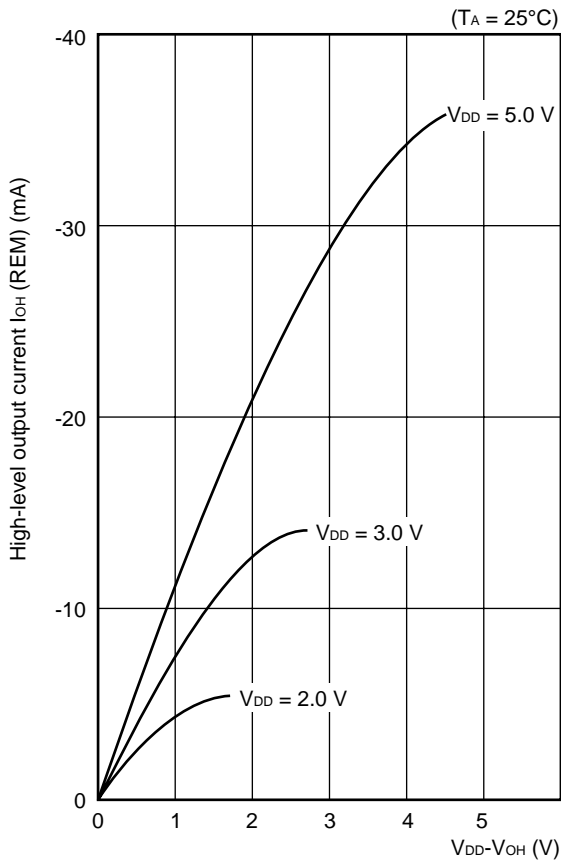

I_{OH} (P0E) vs $V_{DD}-V_{OH}$

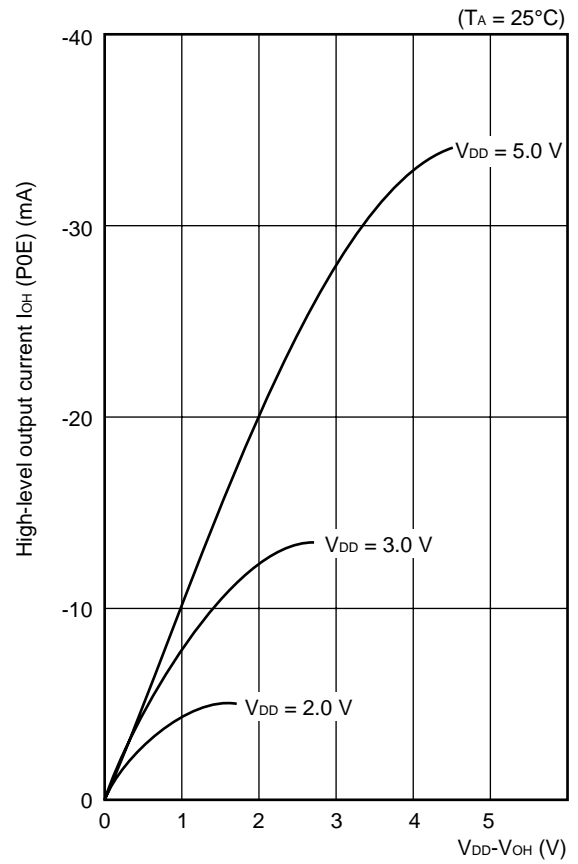

I_{OL} (REM/P0C/P0D) vs V_{OL}

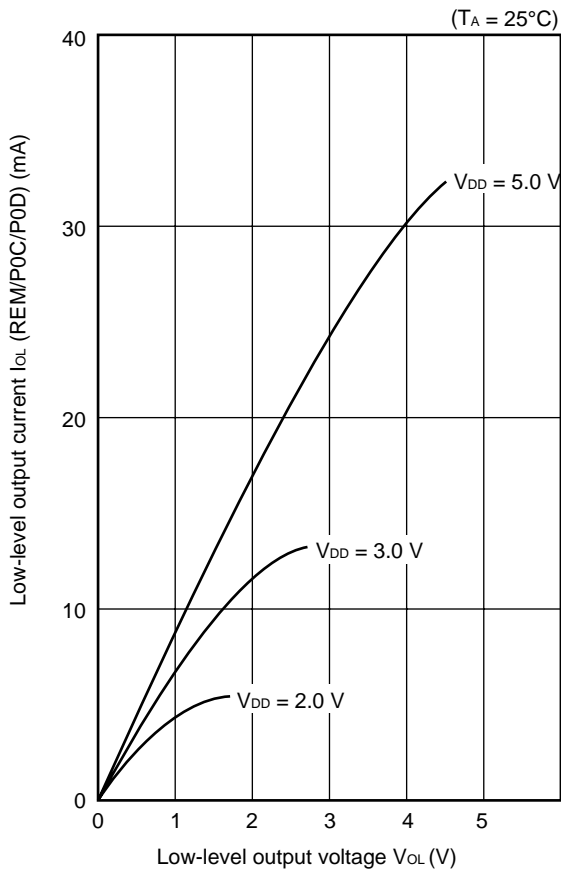

I_{OL} (P0E) vs V_{OL}

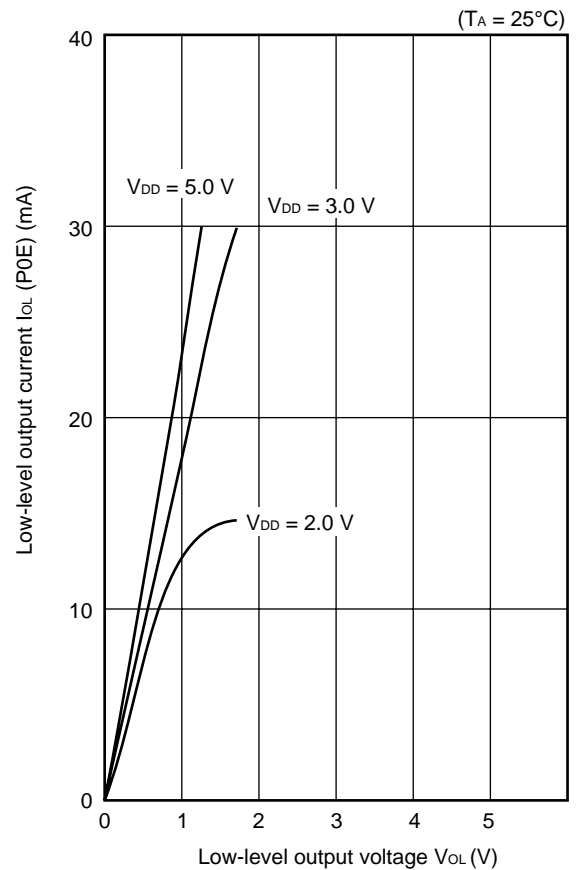

15. APPLICATION CIRCUIT EXAMPLE

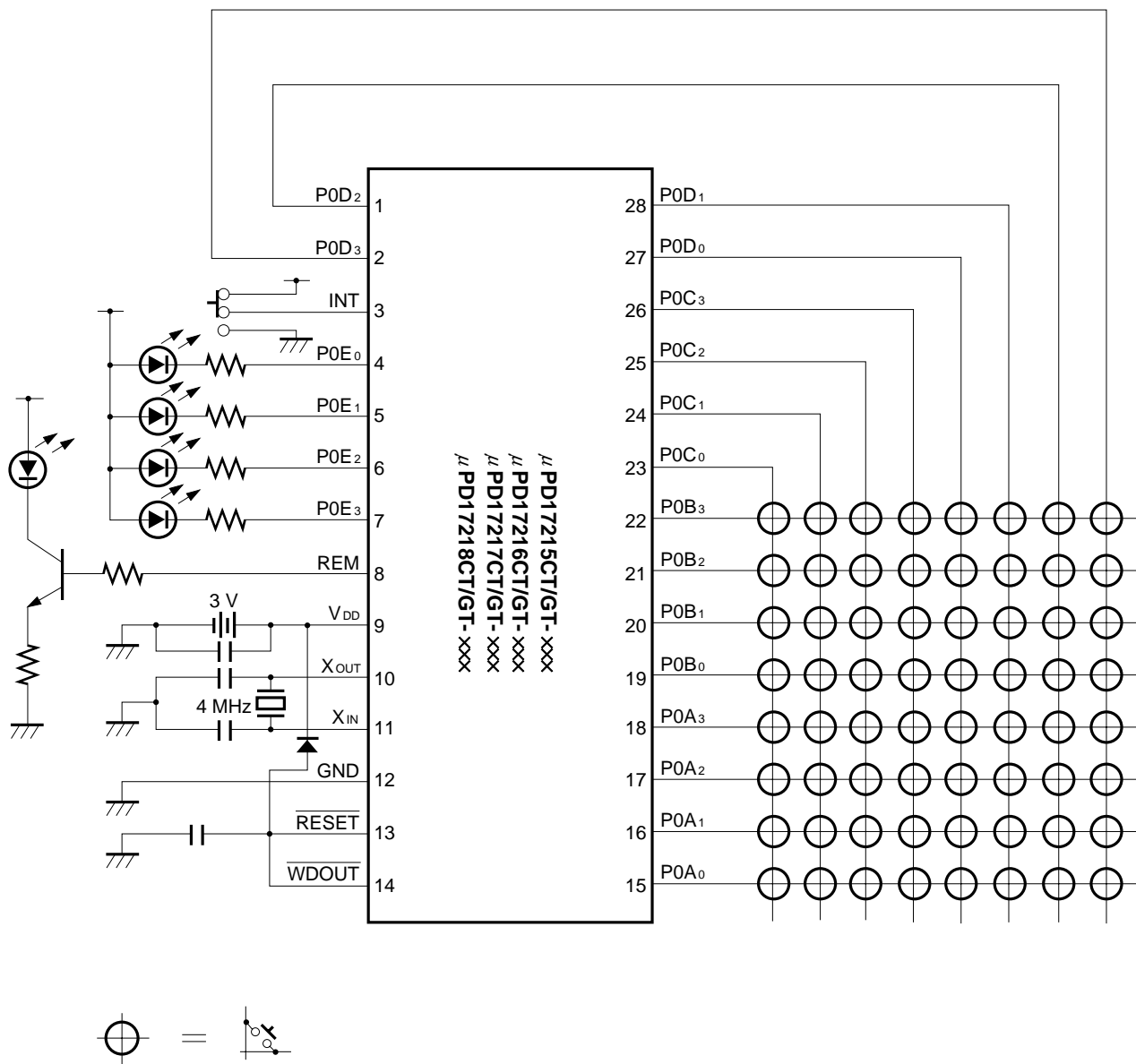

Remark: The $\overline{\text{RESET}}$ pin can be connected to a pull-up resistor by the mask option.

★ 16. PACKAGE DRAWINGS

28 PIN PLASTIC SHRINK DIP (400 mil)

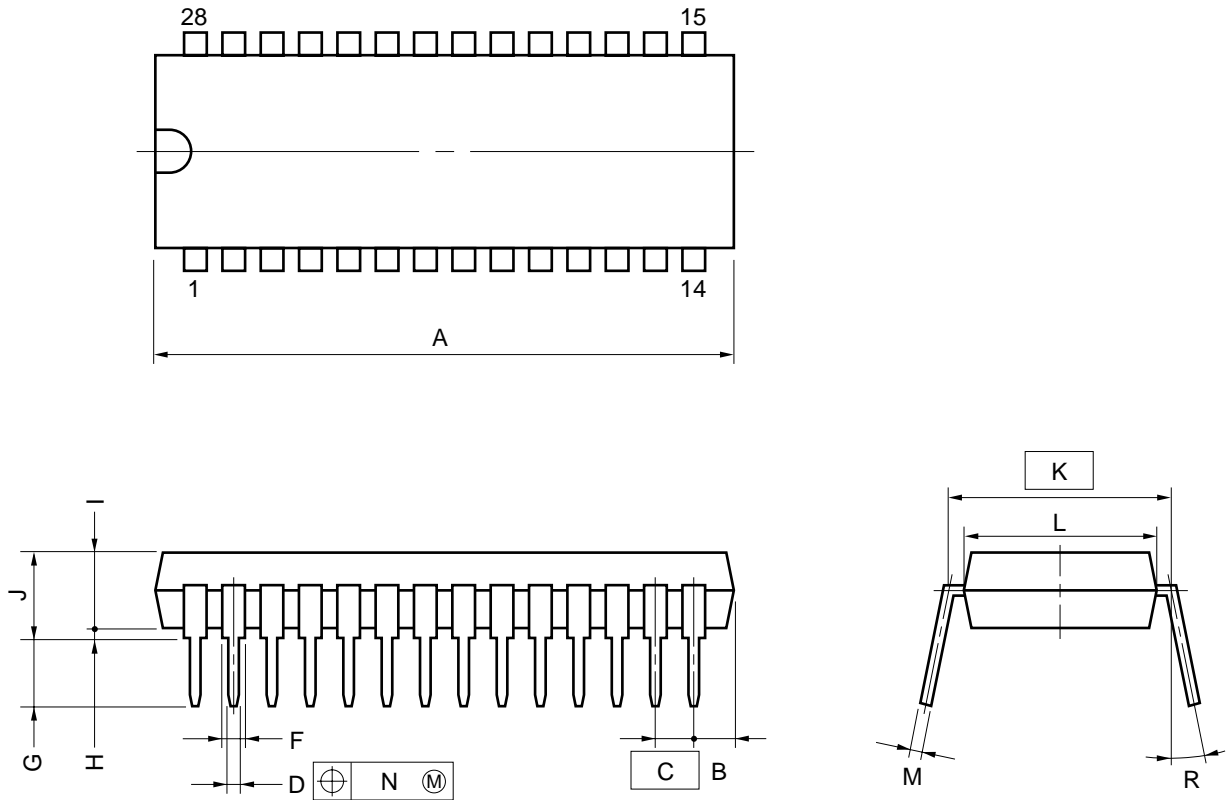

NOTES

- 1) Each lead centerline is located within 0.17 mm (0.007 inch) of its true position (T.P.) at maximum material condition.
- 2) Item "K" to center of leads when formed parallel.

ITEM	MILLIMETERS	INCHES
A	28.46 MAX.	1.121 MAX.
B	2.67 MAX.	0.106 MAX.
C	1.778 (T.P.)	0.070 (T.P.)
D	0.50±0.10	0.020 ^{+0.004} _{-0.005}
F	0.85 MIN.	0.033 MIN.
G	3.2±0.3	0.126±0.012
H	0.51 MIN.	0.020 MIN.
I	4.31 MAX.	0.170 MAX.
J	5.08 MAX.	0.200 MAX.
K	10.16 (T.P.)	0.400 (T.P.)
L	8.6	0.339
M	0.25 ^{+0.10} _{-0.05}	0.010 ^{+0.004} _{-0.003}
N	0.17	0.007
R	0~15°	0~15°

S28C-70-400B-1

28 PIN PLASTIC SOP (375 mil)

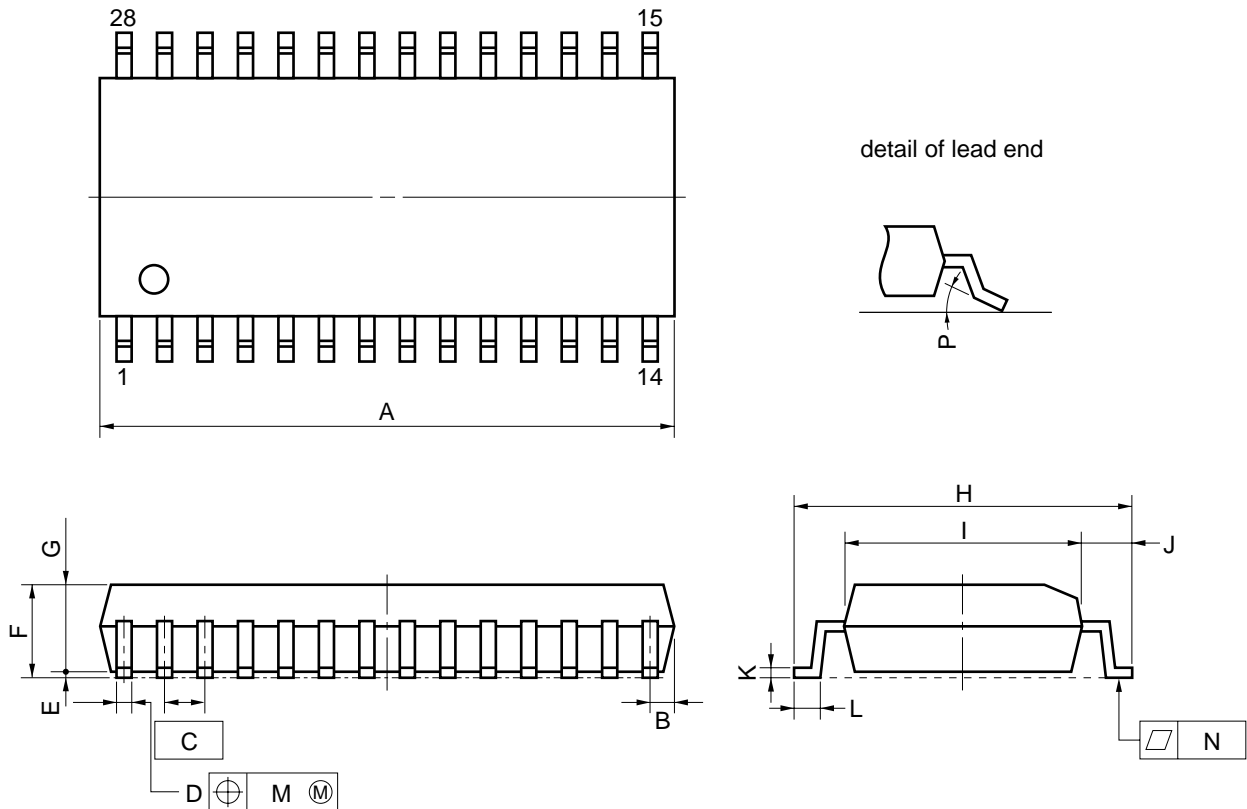

NOTE

Each lead centerline is located within 0.12 mm (0.005 inch) of its true position (T.P.) at maximum material condition.

ITEM	MILLIMETERS	INCHES
A	18.07 MAX.	0.712 MAX.
B	0.78 MAX.	0.031 MAX.
C	1.27 (T.P.)	0.050 (T.P.)
D	0.40 ^{+0.10} _{-0.05}	0.016 ^{+0.004} _{-0.003}
E	0.1±0.1	0.004±0.004
F	2.9 MAX.	0.115 MAX.
G	2.50	0.098
H	10.3±0.3	0.406 ^{+0.012} _{-0.013}
I	7.2	0.283
J	1.6	0.063
K	0.15 ^{+0.10} _{-0.05}	0.006 ^{+0.004} _{-0.002}
L	0.8±0.2	0.031 ^{+0.009} _{-0.008}
M	0.12	0.005
N	0.15	0.006
P	3° ^{+7°} _{-3°}	3° ^{+7°} _{-3°}

P28GM-50-375B-3

17. RECOMMENDED SOLDERING CONDITIONS

For the μPD17215, 17216, 17217, and 17218, soldering must be performed under the following conditions.

For details of recommended conditions for surface mounting, refer to information document "Semiconductor device mounting technology manual" (C10535E).

For other soldering methods, please consult with NEC personnel.

★

Table 17-1 Soldering Conditions of Surface Mount Tye

- μPD17215GT-xxx: 28-pin plastic SOP (375 mil)
- μPD17216GT-xxx: 28-pin plastic SOP (375 mil)
- μPD17217GT-xxx: 28-pin plastic SOP (375 mil)
- μPD17218GT-xxx: 28-pin plastic SOP (375 mil)

Soldering Method	Soldering Conditions	Symbol
Infrared Reflow	Package peak temperature: 235 °C, Time: 30 seconds max. (210 °C min.), Number of times: 2 max., Days: 7 days* (after that, prebaking is necessary for 20 hours at 125 °C) <Cautions> Products other than those supplied in thermal-resistant tray (magazine, taping, and non-thermal-resistant tray) cannot be baked in their packs.	IR35-207-2
VPS	Package peak temperature: 215 °C, Time: 40 seconds max. (210 °C min.), Number of times: 2 max., Days: 7 days* (after that, prebaking is necessary for 20 hours at 125 °C) <Cautions> Products other than those supplied in thermal-resistant tray (magazine, taping, and non-thermal-resistant tray) cannot be baked in their packs.	VP15-207-2
Partial Heating	Pin temperature: 300 °C max., Time: 3 seconds max. (per side of device)	—

*: The number of days the device can be stored after the dry pack was opened, under storage conditions of 25 °C and 65 % RH max.

Caution: Do not use two or more soldering methods in combination (except the partial heating method).

Table 17-2 Soldering Conditions of Through-Hole Tye

- μPD17215CT-xxx: 28-pin plastic shrink DIP (400 mil)
- μPD17216CT-xxx: 28-pin plastic shrink DIP (400 mil)
- μPD17217CT-xxx: 28-pin plastic shrink DIP (400 mil)
- μPD17218CT-xxx: 28-pin plastic shrink DIP (400 mil)

Soldering Method	Soldering Conditions
Wave Soldering (Only for pins)	Solder bath temperature: 260 °C max., Time: 10 seconds max.
Partial Heating	Pin temperature: 300 °C max., Time: 3 seconds max. (per pin)

Caution: The wave soldering must be performed at the lead part only. Note that the solder must not be directly contacted to the package body.

APPENDIX A. DIFFERENCES AMONG μPD17215, 17216, 17217, 17218 AND μPD17P218

μPD17P218 is equipped with PROM to which data can be written by the user instead of the internal mask ROM (program memory) of the μPD17218.

Table A-1 shows the differences between the μPD17215, 17216, 17217, 17218 and μPD17P218.

The differences among these five models are the program memory and mask option, and their CPU functions and internal hardware are identical. Therefore, the μPD17P218 can be used to evaluate the program developed for the μPD17215, 17216, 17217, and 17218 system. **Note, however, that some of the electrical specifications such as supply current and low-voltage detection voltage of the μPD17P218 are different from those of the μPD17215, 17216, 17217, and 17218.**

Table A-1 Differences among μPD17215, 17216, 17217, 17218 and μPD17P218

Item	Product Name	μPD17P218	μPD17215	μPD17216	μPD17217	μPD17218
Program Memory		One-time PROM	Mask ROM			
		16 K bytes (8192 × 16) (0000H-1FFFH)	4 K bytes (2048 × 16) (0000H-07FFFH)	8 K bytes (4096 × 16) (0000H-0FFFFH)	12 K bytes (6144 × 16) (0000H-17FFFH)	16 K bytes (8192 × 16) (0000H-1FFFH)
Data Memory		223 × 4 bits	111 × 4 bits		223 × 4 bits	
Pull-Up Resistor of $\overline{\text{RESET}}$ Pin		Provided	Any (mask option)			
Low-Voltage Detector Circuit *		Provided	Any (mask option)			
V _{PP} Pin, Operation Mode Select Pin		Provided	Not provided			
Instruction Execution Time		2 μs (8 MHz ceramic oscillator: in high-speed mode) 4 μs (4 MHz ceramic oscillator: in high-speed mode) 16 μs (1 MHz ceramic oscillator: in high-speed mode)				
Operation When P0C, P0D Are Standby		Retain output level immediately before standby mode				
Supply Voltage		V _{DD} = 2.2 to 5.5 V (at f _x = 4 MHz, in high-speed mode)				
Package		28-pin plastic SOP (375 mil) 28-pin plastic shrink DIP (400 mil)				

*: Although the circuit configuration is identical, its electrical characteristics differ depending on the product.

APPENDIX B. FUNCTIONAL COMPARISON OF μPD17215 SUBSERIES RELATED PRODUCTS

Product Name		Item						
		μPD17201A	μPD17207	μPD17202A	μPD17215	μPD17216	μPD17217	μPD17218
ROM Capacity (Bit)		3072 × 16	4096 × 16	2048 × 16		4096 × 16	6144 × 16	8192 × 16
RAM Capacity (Bit)		336 × 4		112 × 4	111 × 4		223 × 4	
LCD Controller/Driver		136 segments max.		96 segments max.	Not provided			
Infrared Remote Controller Carrier Generator (REM)		LED output is high-actives		LED output is low-actives	Internal (no LED output)			
I/O Ports		19 lines		16 lines	20 lines			
External Interrupt (INT)		1 line (rising-edge detection)		1 line (rising-edge, falling-edge, detection)				
Analog Input		4-channels (8-bit A/D)		Not provided				
Timer		2-channels { 8-bit timer Watch timer			2-channels { 8-bit timer Basic interval timer			
Watchdog Timer		Internal ($\overline{\text{WDOOUT}}$ output)						
Low-Voltage Detector Circuit*		Not provided			Internal ($\overline{\text{WDOOUT}}$ output)			
Serial Interface		1-channel		Not provided				
Stack		5 levels (3 levels for multiplexed interrupt)						
Instruction Execution Time	Main System Clock	4 μs (4 MHz: with ceramic or crystal oscillator)			<ul style="list-style-type: none"> · 2 μs (8 MHz ceramic oscillator: In high-speed mode) · 4 μs (4 MHz ceramic oscillator: In high-speed mode) · 16 μs (1 MHz ceramic oscillator: In high-speed mode) 			
	Subsystem Clock	488 ms (32.768 kHz: with crystall oscillator)			Not provided			
Supply Voltage (With Subsystem Clock)		$V_{DD} = 2.2$ to 5.5 V ($V_{DD} = 2.0$ to 5.5 V)			$V_{DD} = 2.2$ to 5.5 V			
Standby Function		STOP, HALT						
Package		80-pin plastic QFP		64-pin plastic QFP	28-pin plastic SOP 28-pin plastic shrink DIP			
One-Time PROM Products		μPD17P207		μPD17P202A	μPD17P218			

*: Note that although all the products have the same circuit construction, the electrical specifications differ dependant on each product.

APPENDIX C. DEVELOPMENT TOOLS

To develop the programs for the μPD17215 subseries, the following development tools are available:

Hardware

Name	Remarks
In-Circuit Emulator (IE-17K, IE-17K-ET *1, EMU-17K *2)	IE-17K, IE-17K-ET, and EMU-17K are the in-circuit emulators used in common with the 17K series microcomputer. IE-17K and IE-17K-ET are connected to a PC-9800 series or IBM PC/AT™ as the host machine with RS-232C. EMU-17K is inserted into the expansion slot of a PC-9800 series. By using these in-circuit emulators with a system evaluation board corresponding to the microcomputer, the emulators can emulate the microcomputer. A higher level debugging environment can be provided by using man-machine interface <i>SIMPLEHOST</i> ™. EMU-17K also has a function by which you can check the contents of data memory real-time.
SE Board (SE-17215)	This is an SE board for μPD17215 subseries. It can be used alone to evaluate a system or in combination with an in-circuit emulator for debugging.
Emulation Probe (EP-17K28CT)	EP-17K28CT is an emulation probe for 17K series 28-pin shrink DIP (400mil).
Emulation Probe (EP-17K28GT)	EP-17K28GT is an emulation probe for 17K series 28-pin SOP (375 mil). When used with EV-9500GT-28 ^{Note 3} , it connects an SE board to the target system.
Conversion Adapter (EV-9500GT-28 *3)	EV-9500GT-28 is a conversion adapter for 28-pin SOP (375 mil) and is used to connect EP-17K28GT to the target system.
PROM Programmer (AF-9703 *4, AF-9704 *4, AF-9705 *4, AF-9706 *4)	AF-9703, AF-9704, AF-9705, and AF-9706 are PROM programmers corresponding to μPD17P218. By connecting program adapter AF-9808J or AF-9808H to this PROM programmer, μPD17P218 can be programmed.
Program Adapter (AF-9808J *4, AF-9808H *4)	AF-9808J and AF-9808H are adapters that is used to program μPD17P218CT and μPD17P218GT respectively, and is used in combination with AF-9703, AF-9704, AF-9705, or AF-9706.

*1: Low-cost model: External power supply type

2: This is a product from I.C Corp. For details, consult I.C Corp. (Tel: Tokyo 03-3447-3793).

3: Two EV-9500GT-28s are supplied with the EP-17K28GT. Five EV-9500GT-28s are optionally available as a set.

4: These are products from Ando Electric Co., Ltd. For details, consult Ando Electric Co., Ltd. (Tel: Tokyo 03-3733-1163).

Software

Name	Outline	Host Machine	OS Media		Supply	Order Code
17K Series Assembler (AS17K)	AS17K is an assembler common to the 17K series products. When developing the program of the μPD17215 subseries, AS17K is used in combination with a device file (AS17215, AS17216, AS17217, or AS17218).	PC-9800 series	MS-DOS™		5" 2HD	μS5A10AS17K
					3.5" 2HD	μS5A13AS17K
		IBM PC/AT	PC DOS™		5" 2HC	μS7B10AS17K
					3.5" 2HC	μS7B13AS17K
Device File (AS17215 AS17216 AS17217 AS17218)	AS17215, AS17216, AS17217, and AS17218 are device files for μPD17215, 17216, 17217, and 17218 respectively, and are used in combination with an assembler for the 17K series (AS17K).	PC-9800 series	MS-DOS		5" 2HD	μS5A10AS17215 *
					3.5" 2HD	μS5A10AS17215 *
		IBM PC/AT	PC DOS		5" 2HC	μS5A10AS17215 *
					3.5" 2HC	μS5A10AS17215 *
Support Software (SIMPLE-HOST)	SIMPLEHOST is a software package that enables man-machine interface on the Windows™ when a program is developed by using an in-circuit emulator and a personal computer.	PC-9800 series	MS-DOS	Windows	5" 2HD	μS5A10IE17K
					3.5" 2HD	μS5A13IE17K
		IBM PC/AT	PC DOS		5" 2HC	μS7B10IE17K
					3.5" 2HC	μS7B13IE17K

*: μSxxxxAS17215 includes AS17215, AS17216, AS17217, and AS17218.

Remark: The corresponding OS versions are as follows:

OS	Version
MS-DOS	Ver. 3.30 to Ver. 5.00A *
PC DOS	Ver. 3.1 to Ver. 5.0 *
Windows	Ver. 3.0 to Ver. 3.1

*: Ver. 5.00/5.00A of MS-DOS and Ver. 5.0 of PC DOS have a task swap function, but this function cannot be used with this software.

[MEMO]

NOTES FOR CMOS DEVICES

① PRECAUTION AGAINST ESD FOR SEMICONDUCTORS

Note: Strong electric field, when exposed to a MOS device, can cause destruction of the gate oxide and ultimately degrade the device operation. Steps must be taken to stop generation of static electricity as much as possible, and quickly dissipate it once, when it has occurred. Environmental control must be adequate. When it is dry, humidifier should be used. It is recommended to avoid using insulators that easily build static electricity. Semiconductor devices must be stored and transported in an anti-static container, static shielding bag or conductive material. All test and measurement tools including work bench and floor should be grounded. The operator should be grounded using wrist strap. Semiconductor devices must not be touched with bare hands. Similar precautions need to be taken for PW boards with semiconductor devices on it.

② HANDLING OF UNUSED INPUT PINS FOR CMOS

Note: No connection for CMOS device inputs can be cause of malfunction. If no connection is provided to the input pins, it is possible that an internal input level may be generated due to noise, etc., hence causing malfunction. CMOS device behave differently than Bipolar or NMOS devices. Input levels of CMOS devices must be fixed high or low by using a pull-up or pull-down circuitry. Each unused pin should be connected to V_{DD} or GND with a resistor, if it is considered to have a possibility of being an output pin. All handling related to the unused pins must be judged device by device and related specifications governing the devices.

③ STATUS BEFORE INITIALIZATION OF MOS DEVICES

Note: Power-on does not necessarily define initial status of MOS device. Production process of MOS does not define the initial operation status of the device. Immediately after the power source is turned ON, the devices with reset function have not yet been initialized. Hence, power-on does not guarantee out-pin levels, I/O settings or contents of registers. Device is not initialized until the reset signal is received. Reset operation must be executed immediately after power-on for devices having reset function.

Regional Information

Some information contained in this document may vary from country to country. Before using any NEC product in your application, please contact the NEC office in your country to obtain a list of authorized representatives and distributors. They will verify:

- Device availability
- Ordering information
- Product release schedule
- Availability of related technical literature
- Development environment specifications (for example, specifications for third-party tools and components, host computers, power plugs, AC supply voltages, and so forth)
- Network requirements

In addition, trademarks, registered trademarks, export restrictions, and other legal issues may also vary from country to country.

NEC Electronics Inc. (U.S.)

Santa Clara, California
 Tel: 800-366-9782
 Fax: 800-729-9288

NEC Electronics (Germany) GmbH

Duesseldorf, Germany
 Tel: 0211-65 03 02
 Fax: 0211-65 03 490

NEC Electronics (UK) Ltd.

Milton Keynes, UK
 Tel: 01908-691-133
 Fax: 01908-670-290

NEC Electronics Italiana s.r.l.

Milano, Italy
 Tel: 02-66 75 41
 Fax: 02-66 75 42 99

NEC Electronics (Germany) GmbH

Benelux Office
 Eindhoven, The Netherlands
 Tel: 040-2445845
 Fax: 040-2444580

NEC Electronics (France) S.A.

Velizy-Villacoublay, France
 Tel: 01-30-67 58 00
 Fax: 01-30-67 58 99

NEC Electronics (France) S.A.

Spain Office
 Madrid, Spain
 Tel: 01-504-2787
 Fax: 01-504-2860

NEC Electronics (Germany) GmbH

Scandinavia Office
 Taebby, Sweden
 Tel: 08-63 80 820
 Fax: 08-63 80 388

NEC Electronics Hong Kong Ltd.

Hong Kong
 Tel: 2886-9318
 Fax: 2886-9022/9044

NEC Electronics Hong Kong Ltd.

Seoul Branch
 Seoul, Korea
 Tel: 02-528-0303
 Fax: 02-528-4411

NEC Electronics Singapore Pte. Ltd.

United Square, Singapore 1130
 Tel: 253-8311
 Fax: 250-3583

NEC Electronics Taiwan Ltd.

Taipei, Taiwan
 Tel: 02-719-2377
 Fax: 02-719-5951

NEC do Brasil S.A.

Sao Paulo-SP, Brasil
 Tel: 011-889-1680
 Fax: 011-889-1689

SIMPLEHOST is a trademark of NEC Corporation.

MS-DOS and Windows are trademarks of Microsoft Corporation.

PC/AT and PC DOS are trademarks of IBM Corporation.

The export of this product from Japan is regulated by the Japanese government. To export this product may be prohibited without governmental license, the need for which must be judged by the customer. The export or re-export of this product from a country other than Japan may also be prohibited without a license from that country. Please call an NEC sales representative.

No part of this document may be copied or reproduced in any form or by any means without the prior written consent of NEC Corporation. NEC Corporation assumes no responsibility for any errors which may appear in this document.

NEC Corporation does not assume any liability for infringement of patents, copyrights or other intellectual property rights of third parties by or arising from use of a device described herein or any other liability arising from use of such device. No license, either express, implied or otherwise, is granted under any patents, copyrights or other intellectual property rights of NEC Corporation or others.

While NEC Corporation has been making continuous effort to enhance the reliability of its semiconductor devices, the possibility of defects cannot be eliminated entirely. To minimize risks of damage or injury to persons or property arising from a defect in an NEC semiconductor device, customers must incorporate sufficient safety measures in its design, such as redundancy, fire-containment, and anti-failure features.

NEC devices are classified into the following three quality grades:

"Standard", "Special", and "Specific". The Specific quality grade applies only to devices developed based on a customer designated "quality assurance program" for a specific application. The recommended applications of a device depend on its quality grade, as indicated below. Customers must check the quality grade of each device before using it in a particular application.

Standard: Computers, office equipment, communications equipment, test and measurement equipment, audio and visual equipment, home electronic appliances, machine tools, personal electronic equipment and industrial robots

Special: Transportation equipment (automobiles, trains, ships, etc.), traffic control systems, anti-disaster systems, anti-crime systems, safety equipment and medical equipment (not specifically designed for life support)

Specific: Aircrafts, aerospace equipment, submersible repeaters, nuclear reactor control systems, life support systems or medical equipment for life support, etc.

The quality grade of NEC devices is "Standard" unless otherwise specified in NEC's Data Sheets or Data Books. If customers intend to use NEC devices for applications other than those specified for Standard quality grade, they should contact an NEC sales representative in advance.

Anti-radioactive design is not implemented in this product.