



DS1818 3.3V EconoReset with Pushbutton

www.dalsemi.com

FEATURES

- Automatically restarts a microprocessor after power failure
- Monitors pushbutton for external override
- Maintains reset for 150 ms after V_{CC} returns to an in-tolerance condition
- Reduces need for discrete components
- Precision temperature-compensated voltage reference and voltage sensor
- Accurate 5%, 10% or 20% power monitoring
- Low-cost TO-92 or space saving surface mount SOT-23 packages available
- Efficient open-drain output with internal 5.5 k Ω pull-up resistor
- Operating temperature -40°C to +85°C

PIN ASSIGNMENT

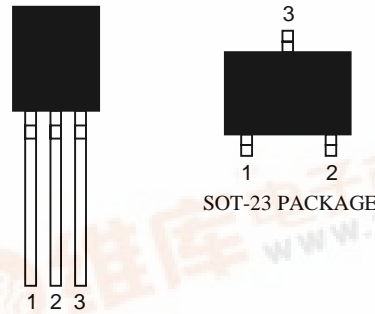

TO-92 PACKAGE
See Mech.
Drawings Section

PIN DESCRIPTION

TO-92

1	\overline{RST}	Active Low Reset Output
2	V_{CC}	Power Supply
3	GND	Ground

SOT-23

1	\overline{RST}	Active Low Reset Output
2	V_{CC}	Power Supply
3	GND	Ground

DESCRIPTION

The DS1818 EconoReset uses a precision temperature-compensated reference and comparator circuit to monitor the status of the power supply (V_{CC}). When an out-of-tolerance condition is detected, an internal power-fail signal is generated which forces reset to the active state. When V_{CC} returns to an in-tolerance condition, the reset signal is kept in the active state for approximately 150 ms to allow the power supply and processor to stabilize.

The DS1818 also monitors a pushbutton on the reset output. If the reset line is pulled low, a reset is generated upon release and the DS1818 output will be held in reset output low for typically 150 ms.



OPERATION - POWER MONITOR

The DS1818 provides the functions of detecting out-of-tolerance power supply conditions and warning a processor-based system of impending power failures. When V_{CC} is detected as out-of-tolerance, the \overline{RST} signal is asserted. On power-up, \overline{RST} is kept active for approximately 150 ms after the power supply has reached the selected tolerance. This allows the power supply and microprocessor to stabilize before \overline{RST} is released.

BLOCK DIAGRAM (OPEN-DRAIN OUTPUT) Figure 1

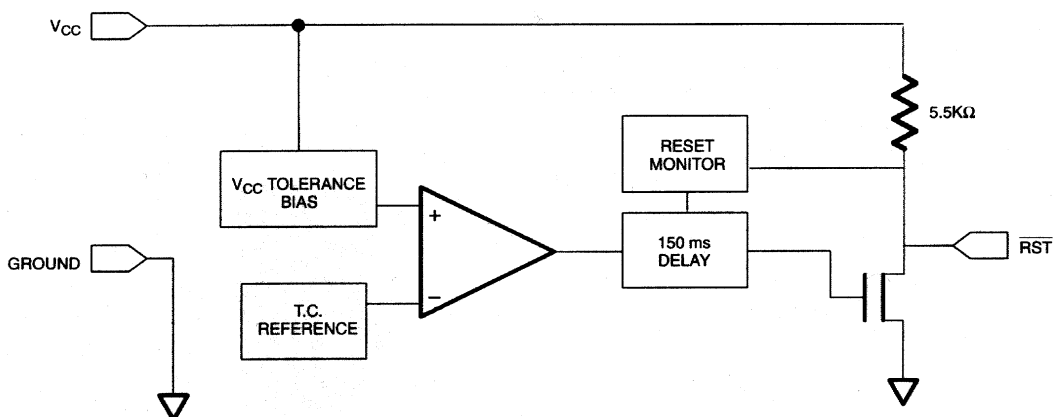

APPLICATION EXAMPLE Figure 2

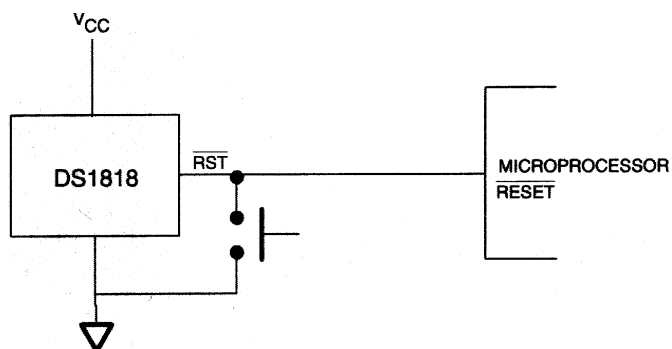

OPERATION - PUSHBUTTON RESET

The DS1818 provides a pushbutton switch for manual reset control. When the DS1818 is not in a reset cycle, a pushbutton reset can be generated by pulling the \overline{RST} pin low for at least $1\ \mu\text{s}$. When the pushbutton is held low, the \overline{RST} is forced active low and will remain active low for about 150 ms after the pushbutton is released. See Figure 2 for an application example and Figure 3 for the timing diagram.

TIMING DIAGRAM: PUSHBUTTON RESET Figure 3

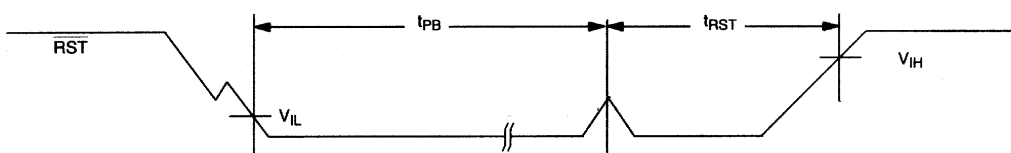

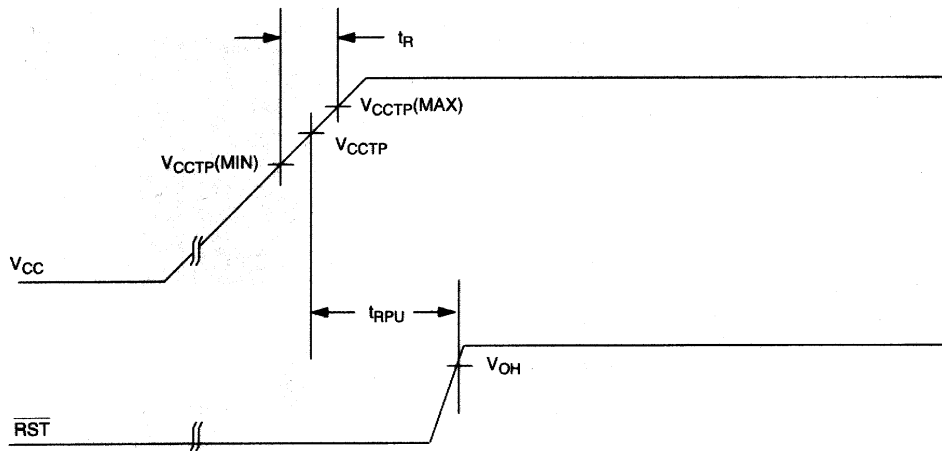
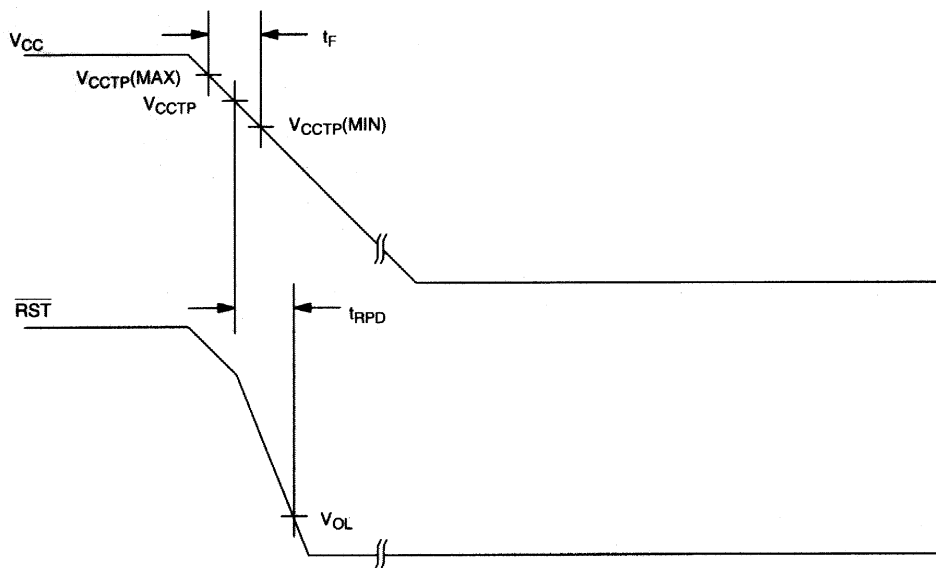
TIMING DIAGRAM: POWER-UP Figure 4**TIMING DIAGRAM: POWER-DOWN** Figure 5

ABSOLUTE MAXIMUM RATINGS*

Voltage on V_{CC} Pin Relative to Ground	-0.5V to +7.0V
Voltage on \overline{RST} Relative to Ground	-0.5V to +5 V_{CC} +0.5V
Operating Temperature	-40°C to +85°C
Storage Temperature	-55°C to +125°C
Soldering Temperature	260°C for 10 seconds

* This is a stress rating only and functional operation of the device at these or any other conditions above those indicated in the operation sections of this specification is not implied. Exposure to absolute maximum rating conditions for extended periods of time may affect reliability.

RECOMMENDED DC OPERATING CONDITIONS (-40°C to +85°C)

PARAMETER	SYMBOL	MIN	TYP	MAX	UNITS	NOTES
Supply Voltage	V_{CC}	1.0		5.5	V	1

DC ELECTRICAL CHARACTERISTICS (-40°C to +85°C; $V_{CC}=1.2V$ to 5.5V)

PARAMETER	SYMBOL	MIN	TYP	MAX	UNITS	NOTES
Output Current @ 0.4 V	I_{OL}	+10			mA	2, 3
Voltage Input Low	V_{IL}			0.4	V	1
Voltage Input High	V_{IH}	0.7 * V_{CC}			V	1
Operating Current $V_{CC} < 5.5V$	I_{CC}		28	35	μA	4
V_{CC} Trip Point (DS1818-5)	V_{CCTP}	2.98	3.06	3.15	V	1
V_{CC} Trip Point (DS1818-10)	V_{CCTP}	2.80	2.88	2.97	V	1
V_{CC} Trip Point (DS1818-20)	V_{CCTP}	2.47	2.55	2.64	V	1
Internal Pull-up Resistor	R_P	3.50	5.5	7.5	k Ω	7
Output Capacitance	C_{OUT}			10	pF	

AC ELECTRICAL CHARACTERISTICS (-40°C to +85°C; $V_{CC}=1.2V$ to 5.5V)

PARAMETER	SYMBOL	MIN	TYP	MAX	UNITS	NOTES
RESET Active Time	t_{RST}	100	150	250	ms	5
V_{CC} Detect to \overline{RST}	t_{RPD}		2	5	μs	
V_{CC} Slew Rate (V_{CCTP} (MAX) to V_{CCTP} (MIN))	t_F	300			μs	8
V_{CC} Slew Rate (V_{CCTP} (MIN) to V_{CCTP} (MAX))	t_R	0			ns	
V_{CC} Detect to \overline{RST}	t_{RPU}	100	150	250	ms	5, 6
Pushbutton Detect to \overline{RST}	t_{PB}	1			μs	
Pushbutton Reset	t_{PBRST}	100	150	250	ms	5

NOTES:

1. All voltages are referenced to ground.
2. Measured with $V_{CC} \geq 2.7V$.
3. A 1 k Ω external pull-up resistor may be required in some applications for proper operation of the microprocessor reset control circuit.
4. Measured with \overline{RST} output open.
5. Measured with $2.7V \leq V_{CC} \leq 3.3V$.
6. $t_R = 5 \mu s$.
7. V_{OH} and I_{OH} are a function of the value of R_P and the associated output load conditions.
8. The t_F value is for reference in defining values for t_{RPD} and should not be considered a requirement for proper operation or use of the device.

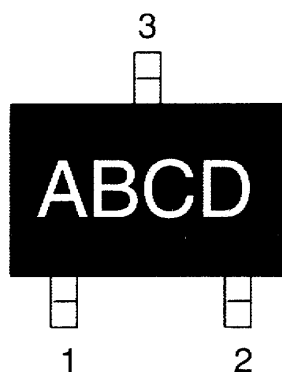
PART MARKING CODES

“A”, “B”, & “C” represent the device type.

810	-	DS1810
811	-	DS1811
812	-	DS1812
813	-	DS1813
815	-	DS1815
816	-	DS1816
817	-	DS1817
818	-	DS1818

“D” represents the device tolerance.

A	-	5%
B	-	10%
C	-	15%
D	-	20%