



August 2003

# LMV431/LMV431A/LMV431B

## Low-Voltage (1.24V) Adjustable Precision Shunt Regulators

### General Description

The LMV431, LMV431A and LMV431B are precision 1.24V shunt regulators capable of adjustment to 30V. Negative feedback from the cathode to the adjust pin controls the cathode voltage, much like a non-inverting op amp configuration (Refer to Symbol and Functional diagrams). A two resistor voltage divider terminated at the adjust pin controls the gain of a 1.24V band-gap reference. Shorting the cathode to the adjust pin (voltage follower) provides a cathode voltage of a 1.24V.

The LMV431, LMV431A and LMV431B have respective initial tolerances of 1.5%, 1% and 0.5%, and functionally lends themselves to several applications that require zener diode type performance at low voltages. Applications include a 3V to 2.7V low drop-out regulator, an error amplifier in a 3V off-line switching regulator and even as a voltage detector. These parts are typically stable with capacitive loads greater than 10nF and less than 50pF.

The LMV431, LMV431A and LMV431B provide performance at a competitive price.

### Features

- Low Voltage Operation/Wide Adjust Range (1.24V/30V)
- 0.5% Initial Tolerance (LMV431B)
- Temperature Compensated for Industrial Temperature Range (39 PPM/°C for the LMV431A)
- Low Operation Current (55µA)
- Low Output Impedance (0.25Ω)
- Fast Turn-On Response
- Low Cost

### Applications

- Shunt Regulator
- Series Regulator
- Current Source or Sink
- Voltage Monitor
- Error Amplifier
- 3V Off-Line Switching Regulator
- Low Dropout N-Channel Series Regulator

### Connection Diagrams

TO92: Plastic Package

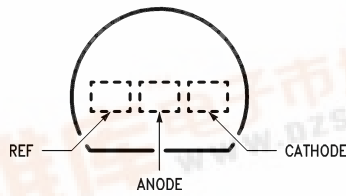

Top View

SOT23-3

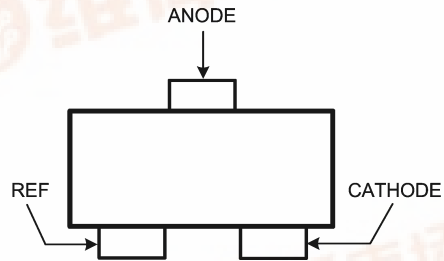

Top View

SOT23-5

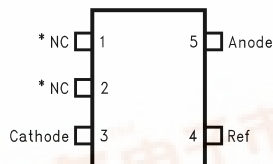

Top View

\*Pin 1 is not internally connected.

\*Pin 2 is internally connected to Anode pin. Pin 2 should be either floating or connected to Anode pin.

LMV431/LMV431A/LMV431B Low-Voltage (1.24V) Adjustable Precision Shunt Regulators



### Symbol and Functional Diagrams

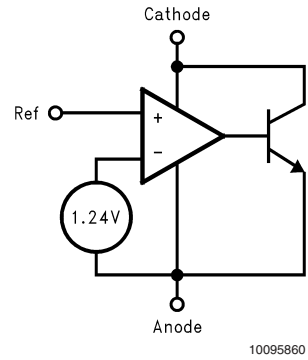
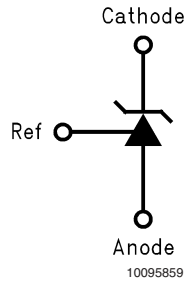

### Simplified Schematic

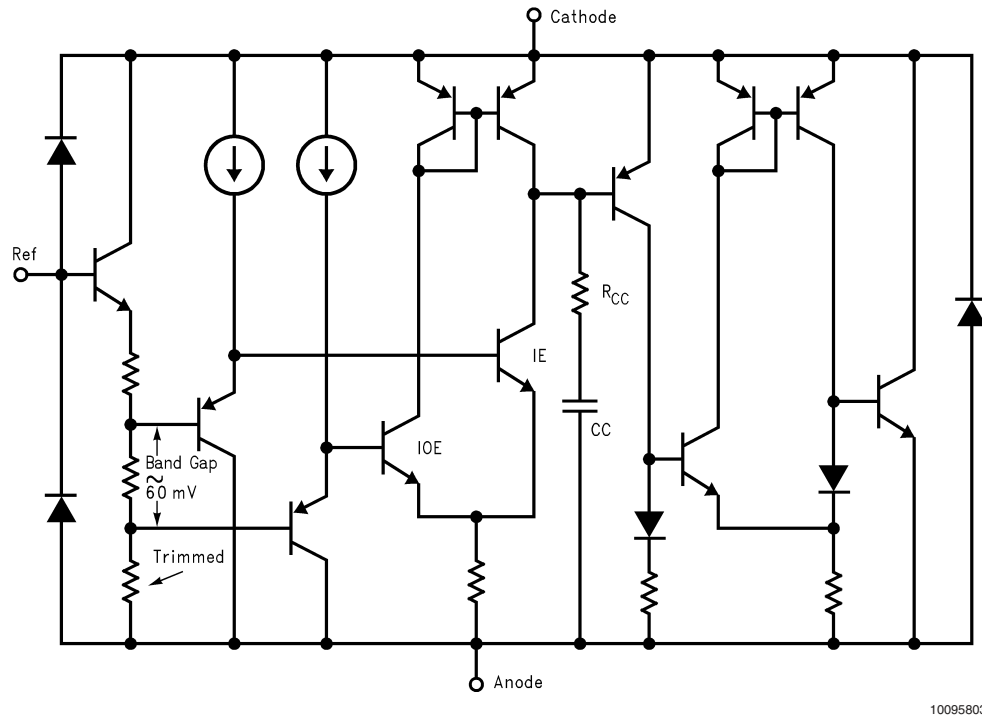

## Ordering Information

Package	Temperature Range	Voltage Tolerance	Part Number	Package Marking	NSC Drawing
TO92	Industrial Range -40°C to +85°C	1%	LMV431AIZ	LMV431AIZ	Z03A
		1.5%	LMV431IZ	LMV431IZ	
	Commercial Range 0°C to +70°C	0.5%	LMV431BCZ	LMV431BCZ	
		1%	LMV431ACZ	LMV431ACZ	
		1.5%	LMV431CZ	LMV431CZ	
SOT23-5	Industrial Range -40°C to +85°C	1%	LMV431AIM5	N08A	MF05A
		1%	LMV431AIM5X	N08A	
		1.5%	LMV431IM5	N08B	
		1.5%	LMV431IM5X	N08B	
	Commercial Range 0°C to +70°C	0.5%	LMV431BCM5	N09C	
		0.5%	LMV431BCM5X	N09C	
		1%	LMV431ACM5	N09A	
		1%	LMV431ACM5X	N09A	
		1.5%	LMV431CM5	N09B	
		1.5%	LMV431CM5X	N09B	
SOT23-3	Industrial Range -40° to +85°C	0.5%	LMV431BIMF	RLB	MF03A
		0.5%	LMV431BIMFX		
		1%	LMV431AIMF	RLA	
		1%	LMV431AIMFX		

## DC/AC Test Circuits for Table and Curves

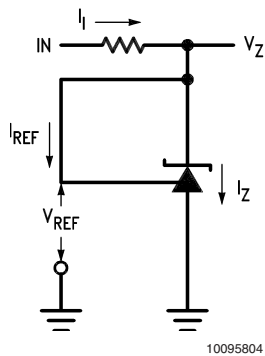
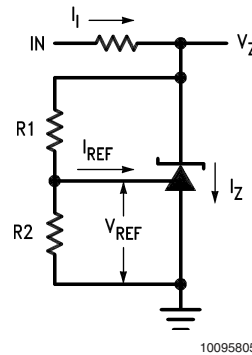

FIGURE 1. Test Circuit for  $V_Z = V_{REF}$



Note:  $V_Z = V_{REF} (1 + R1/R2) + I_{REF} \cdot R1$

FIGURE 2. Test Circuit for  $V_Z > V_{REF}$

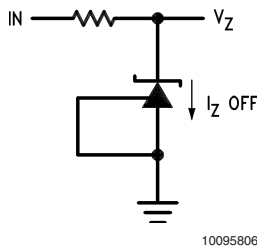

FIGURE 3. Test Circuit for Off-State Current

## Absolute Maximum Ratings (Note 1)

If Military/Aerospace specified devices are required, please contact the National Semiconductor Sales Office/Distributors for availability and specifications.

Storage Temperature Range	-65°C to +150°C
Operating Temperature Range	
Industrial (LMV431AI, LMV431I)	-40°C to +85°C
Commercial (LMV431AC, LMV431C, LMV431BC)	0°C to +70°C
Lead Temperature	
TO92 Package/SOT23 -5,-3 Package (Soldering, 10 sec.)	265°C
Internal Power Dissipation (Note 2)	
TO92	0.78W
SOT23-5, -3 Package	0.28W
Cathode Voltage	35V
Continuous Cathode Current	-30 mA to +30mA
Reference Input Current range	-.05mA to 3mA

Cathode Current	0.1 mA to 15mA
Temperature range	
LMV431AI	-40°C ≤ T <sub>A</sub> ≤ 85°C
Thermal Resistance (θ <sub>JA</sub> )(Note 3)	
SOT23-5, -3 Package	455 °C/W
TO-92 Package	161 °C/W
Derating Curve (Slope = -1/θ <sub>JA</sub> )	

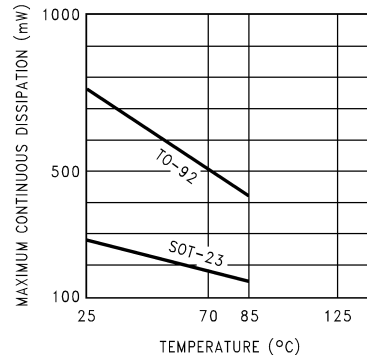

10095830

## Operating Conditions

Cathode Voltage V<sub>REF</sub> to 30V

## LMV431C Electrical Characteristics

T<sub>A</sub> = 25°C unless otherwise specified

Symbol	Parameter	Conditions	Min	Typ	Max	Units
V <sub>REF</sub>	Reference Voltage	V <sub>Z</sub> = V <sub>REF</sub> , I <sub>Z</sub> = 10mA (See Figure 1)	T <sub>A</sub> = 25°C 1.222	1.24	1.258	V
			T <sub>A</sub> = Full Range 1.21		1.27	
V <sub>DEV</sub>	Deviation of Reference Input Voltage Over Temperature (Note 4)	V <sub>Z</sub> = V <sub>REF</sub> , I <sub>Z</sub> = 10mA, T <sub>A</sub> = Full Range (See Figure 1)		4	12	mV
$\frac{\Delta V_{REF}}{\Delta V_Z}$	Ratio of the Change in Reference Voltage to the Change in Cathode Voltage	I <sub>Z</sub> = 10mA (see Figure 2) V <sub>Z</sub> from V <sub>REF</sub> to 6V R <sub>1</sub> = 10k, R <sub>2</sub> = ∞ and 2.6k		-1.5	-2.7	mV/V
I <sub>REF</sub>	Reference Input Current	R <sub>1</sub> = 10kΩ, R <sub>2</sub> = ∞ I <sub>1</sub> = 10mA (see Figure 2)		0.15	0.5	μA
∞I <sub>REF</sub>	Deviation of Reference Input Current over Temperature	R <sub>1</sub> = 10kΩ, R <sub>2</sub> = ∞, I <sub>1</sub> = 10mA, T <sub>A</sub> = Full Range (see Figure 2)		0.05	0.3	μA
I <sub>Z(MIN)</sub>	Minimum Cathode Current for Regulation	V <sub>Z</sub> = V <sub>REF</sub> (see Figure 1)		55	80	μA
I <sub>Z(OFF)</sub>	Off-State Current	V <sub>Z</sub> =6V, V <sub>REF</sub> = 0V (see Figure 3)		0.001	0.1	μA
r <sub>Z</sub>	Dynamic Output Impedance (Note 5)	V <sub>Z</sub> = V <sub>REF</sub> , I <sub>Z</sub> = 0.1mA to 15mA Frequency = 0Hz (see Figure 1)		0.25	0.4	Ω

## LMV431I Electrical Characteristics

$T_A = 25^\circ\text{C}$  unless otherwise specified

Symbol	Parameter	Conditions	Min	Typ	Max	Units
$V_{REF}$	Reference Voltage	$V_Z = V_{REF}$ , $I_Z = 10\text{mA}$ (See Figure 1)	$T_A = 25^\circ\text{C}$ 1.222	1.24	1.258	V
			$T_A = \text{Full Range}$ 1.202		1.278	
$V_{DEV}$	Deviation of Reference Input Voltage Over Temperature (Note 4)	$V_Z = V_{REF}$ , $I_Z = 10\text{mA}$ , $T_A = \text{Full Range}$ (See Figure 1)		6	20	mV
$\frac{\Delta V_{REF}}{\Delta V_Z}$	Ratio of the Change in Reference Voltage to the Change in Cathode Voltage	$I_Z = 10\text{mA}$ (see Figure 2) $V_Z$ from $V_{REF}$ to 6V $R_1 = 10\text{k}$ , $R_2 = \infty$ and 2.6k		-1.5	-2.7	mV/V
$I_{REF}$	Reference Input Current	$R_1 = 10\text{k}\Omega$ , $R_2 = \infty$ $I_1 = 10\text{mA}$ (see Figure 2)		0.15	0.5	$\mu\text{A}$
$\infty I_{REF}$	Deviation of Reference Input Current over Temperature	$R_1 = 10\text{k}\Omega$ , $R_2 = \infty$ , $I_1 = 10\text{mA}$ , $T_A = \text{Full Range}$ (see Figure 2)		0.1	0.4	$\mu\text{A}$
$I_{Z(MIN)}$	Minimum Cathode Current for Regulation	$V_Z = V_{REF}$ (see Figure 1)		55	80	$\mu\text{A}$
$I_{Z(OFF)}$	Off-State Current	$V_Z = 6\text{V}$ , $V_{REF} = 0\text{V}$ (see Figure 3)		0.001	0.1	$\mu\text{A}$
$r_Z$	Dynamic Output Impedance (Note 5)	$V_Z = V_{REF}$ , $I_Z = 0.1\text{mA}$ to 15mA Frequency = 0Hz (see Figure 1)		0.25	0.4	$\Omega$

## LMV431AC Electrical Characteristics

$T_A = 25^\circ\text{C}$  unless otherwise specified

Symbol	Parameter	Conditions	Min	Typ	Max	Units
$V_{REF}$	Reference Voltage	$V_Z = V_{REF}$ , $I_Z = 10\text{mA}$ (See Figure 1)	$T_A = 25^\circ\text{C}$ 1.228	1.24	1.252	V
			$T_A = \text{Full Range}$ 1.221		1.259	
$V_{DEV}$	Deviation of Reference Input Voltage Over Temperature (Note 4)	$V_Z = V_{REF}$ , $I_Z = 10\text{mA}$ , $T_A = \text{Full Range}$ (See Figure 1)		4	12	mV
$\frac{\Delta V_{REF}}{\Delta V_Z}$	Ratio of the Change in Reference Voltage to the Change in Cathode Voltage	$I_Z = 10\text{mA}$ (see Figure 2) $V_Z$ from $V_{REF}$ to 6V $R_1 = 10\text{k}$ , $R_2 = \infty$ and 2.6k		-1.5	-2.7	mV/V
$I_{REF}$	Reference Input Current	$R_1 = 1\text{k}\Omega$ , $R_2 = \infty$ $I_1 = 10\text{mA}$ (see Figure 2)		0.15	0.50	$\mu\text{A}$
$\infty I_{REF}$	Deviation of Reference Input Current over Temperature	$R_1 = 10\text{k}\Omega$ , $R_2 = \infty$ , $I_1 = 10\text{mA}$ , $T_A = \text{Full Range}$ (see Figure 2)		0.05	0.3	$\mu\text{A}$
$I_{Z(MIN)}$	Minimum Cathode Current for Regulation	$V_Z = V_{REF}$ (see Figure 1)		55	80	$\mu\text{A}$
$I_{Z(OFF)}$	Off-State Current	$V_Z = 6\text{V}$ , $V_{REF} = 0\text{V}$ (see Figure 3)		0.001	0.1	$\mu\text{A}$
$r_Z$	Dynamic Output Impedance (Note 5)	$V_Z = V_{REF}$ , $I_Z = 0.1\text{mA}$ to 15mA Frequency = 0 Hz (see Figure 1)		0.25	0.4	$\Omega$

**LMV431AI Electrical Characteristics** $T_A = 25^\circ\text{C}$  unless otherwise specified

Symbol	Parameter	Conditions	Min	Typ	Max	Units	
$V_{REF}$	Reference Voltage	$V_Z = V_{REF}$ , $I_Z = 10\text{mA}$ (See Figure 1)	$T_A = 25^\circ\text{C}$	1.228	1.24	1.252	V
			$T_A = \text{Full Range}$	1.215		1.265	
$V_{DEV}$	Deviation of Reference Input Voltage Over Temperature (Note 4)	$V_Z = V_{REF}$ , $I_Z = 10\text{mA}$ , $T_A = \text{Full Range}$ (See Figure 1)		6	20	mV	
$\frac{\Delta V_{REF}}{\Delta V_Z}$	Ratio of the Change in Reference Voltage to the Change in Cathode Voltage	$I_Z = 10\text{mA}$ (see Figure 2) $V_Z$ from $V_{REF}$ to 6V $R_1 = 10\text{k}$ , $R_2 = \infty$ and 2.6k		-1.5	-2.7	mV/V	
$I_{REF}$	Reference Input Current	$R_1 = 10\text{k}\Omega$ , $R_2 = \infty$ $I_1 = 10\text{mA}$ (see Figure 2)		0.15	0.5	$\mu\text{A}$	
$\infty I_{REF}$	Deviation of Reference Input Current over Temperature	$R_1 = 10\text{k}\Omega$ , $R_2 = \infty$ , $I_1 = 10\text{mA}$ , $T_A = \text{Full Range}$ (see Figure 2)		0.1	0.4	$\mu\text{A}$	
$I_{Z(MIN)}$	Minimum Cathode Current for Regulation	$V_Z = V_{REF}$ (see Figure 1)		55	80	$\mu\text{A}$	
$I_{Z(OFF)}$	Off-State Current	$V_Z = 6\text{V}$ , $V_{REF} = 0\text{V}$ (see Figure 3)		0.001	0.1	$\mu\text{A}$	
$r_Z$	Dynamic Output Impedance (Note 5)	$V_Z = V_{REF}$ , $I_Z = 0.1\text{mA}$ to 15mA Frequency = 0Hz (see Figure 1)		0.25	0.4	$\Omega$	

**LMV431BC Electrical Characteristics** $T_A = 25^\circ\text{C}$  unless otherwise specified

Symbol	Parameter	Conditions	Min	Typ	Max	Units	
$V_{REF}$	Reference Voltage	$V_Z = V_{REF}$ , $I_Z = 10\text{mA}$ (See Figure 1)	$T_A = 25^\circ\text{C}$	1.234	1.24	1.246	V
			$T_A = \text{Full Range}$	1.227		1.253	
$V_{DEV}$	Deviation of Reference Input Voltage Over Temperature (Note 4)	$V_Z = V_{REF}$ , $I_Z = 10\text{mA}$ , $T_A = \text{Full Range}$ (See Figure 1)		4	12	mV	
$\frac{\Delta V_{REF}}{\Delta V_Z}$	Ratio of the Change in Reference Voltage to the Change in Cathode Voltage	$I_Z = 10\text{mA}$ (see Figure 2) $V_Z$ from $V_{REF}$ to 6V $R_1 = 10\text{k}$ , $R_2 = \infty$ and 2.6k		-1.5	-2.7	mV/V	
$I_{REF}$	Reference Input Current	$R_1 = 10\text{k}\Omega$ , $R_2 = \infty$ $I_1 = 10\text{mA}$ (see Figure 2)		0.15	0.50	$\mu\text{A}$	
$\infty I_{REF}$	Deviation of Reference Input Current over Temperature	$R_1 = 10\text{k}\Omega$ , $R_2 = \infty$ , $I_1 = 10\text{mA}$ , $T_A = \text{Full Range}$ (see Figure 2)		0.05	0.3	$\mu\text{A}$	
$I_{Z(MIN)}$	Minimum Cathode Current for Regulation	$V_Z = V_{REF}$ (see Figure 1)		55	80	$\mu\text{A}$	
$I_{Z(OFF)}$	Off-State Current	$V_Z = 6\text{V}$ , $V_{REF} = 0\text{V}$ (see Figure 3)		0.001	0.1	$\mu\text{A}$	
$r_Z$	Dynamic Output Impedance (Note 5)	$V_Z = V_{REF}$ , $I_Z = 0.1\text{mA}$ to 15mA Frequency = 0Hz (see Figure 1)		0.25	0.4	$\Omega$	

**LMV431BI Electrical Characteristics** $T_A = 25^\circ\text{C}$  unless otherwise specified

Symbol	Parameter	Conditions	Min	Typ	Max	Units	
$V_{REF}$	Reference Voltage	$V_Z = V_{REF}$ , $I_Z = 10\text{mA}$ (See Figure 1)	$T_A = 25^\circ\text{C}$	1.234	1.24	1.246	V
			$T_A = \text{Full Range}$	1.224		1.259	
$V_{DEV}$	Deviation of Reference Input Voltage Over Temperature (Note 4)	$V_Z = V_{REF}$ , $I_Z = 10\text{mA}$ , $T_A = \text{Full Range}$ (See Figure 1)		6	20	mV	
$\frac{\Delta V_{REF}}{\Delta V_Z}$	Ratio of the Change in Reference Voltage to the Change in Cathode Voltage	$I_Z = 10\text{mA}$ (see Figure 2) $V_Z$ from $V_{REF}$ to 6V $R_1 = 10\text{k}$ , $R_2 = \infty$ and 2.6k		-1.5	-2.7	mV/V	
$I_{REF}$	Reference Input Current	$R_1 = 10\text{k}\Omega$ , $R_2 = \infty$ $I_1 = 10\text{mA}$ (see Figure 2)		0.15	0.50	$\mu\text{A}$	

**LMV431BI Electrical Characteristics** (Continued) $T_A = 25^\circ\text{C}$  unless otherwise specified

Symbol	Parameter	Conditions	Min	Typ	Max	Units
$\infty I_{REF}$	Deviation of Reference Input Current over Temperature	$R_1 = 10\text{k}\Omega$ , $R_2 = \infty$ , $I_I = 10\text{mA}$ , $T_A = \text{Full Range}$ (see Figure 2)		0.1	0.4	$\mu\text{A}$
$I_{Z(MIN)}$	Minimum Cathode Current for Regulation	$V_Z = V_{REF}$ (see Figure 1)		55	80	$\mu\text{A}$
$I_{Z(OFF)}$	Off-State Current	$V_Z = 6\text{V}$ , $V_{REF} = 0\text{V}$ (see Figure 3)		0.001	0.1	$\mu\text{A}$
$r_Z$	Dynamic Output Impedance (Note 5)	$V_Z = V_{REF}$ , $I_Z = 0.1\text{mA}$ to $15\text{mA}$ Frequency = $0\text{Hz}$ (see Figure 1)		0.25	0.4	$\Omega$

**Note 1:** Absolute Maximum Ratings indicate limits beyond which damage to the device may occur. Electrical specifications do not apply when operating the device beyond its rated operating conditions.

**Note 2:** Ratings apply to ambient temperature at  $25^\circ\text{C}$ . Above this temperature, derate the TO92 at  $6.2\text{ mW}/^\circ\text{C}$ , and the SOT23-5 at  $2.2\text{ mW}/^\circ\text{C}$ . See derating curve in Operating Condition section..

**Note 3:**  $T_{J\text{ Max}} = 150^\circ\text{C}$ ,  $T_J = T_A + (\theta_{JA} P_D)$ , where  $P_D$  is the operating power of the device.

**Note 4:** Deviation of reference input voltage,  $V_{DEV}$ , is defined as the maximum variation of the reference input voltage over the full temperature range.

See following:

## LMV431BI Electrical Characteristics (Continued)

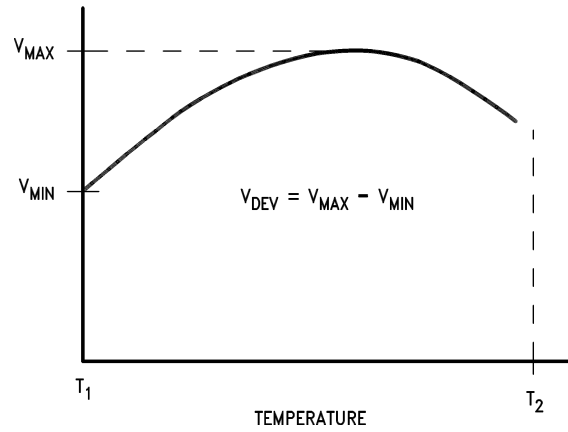

The average temperature coefficient of the reference input voltage,  $\alpha V_{REF}$ , is defined as:

$$\alpha V_{REF} \frac{\text{ppm}}{^{\circ}\text{C}} = \frac{\pm \left[ \frac{V_{\text{Max}} - V_{\text{Min}}}{V_{\text{REF}}(\text{at } 25^{\circ}\text{C})} \right] 10^6}{T_2 - T_1} = \frac{\pm \left[ \frac{V_{\text{DEV}}}{V_{\text{REF}}(\text{at } 25^{\circ}\text{C})} \right] 10^6}{T_2 - T_1}$$

Where:

$T_2 - T_1$  = full temperature change.

$\alpha V_{REF}$  can be positive or negative depending on whether the slope is positive or negative.

Example:  $V_{\text{DEV}} = 6.0\text{mV}$ ,  $V_{\text{REF}} = 1240\text{mV}$ ,  $T_2 - T_1 = 125^{\circ}\text{C}$ .

$$\alpha V_{REF} = \frac{\left[ \frac{6.0 \text{ mV}}{1240 \text{ mV}} \right] 10^6}{125^{\circ}\text{C}} = +39 \text{ ppm}/^{\circ}\text{C}$$

**Note 5:** The dynamic output impedance,  $r_z$ , is defined as:

$$r_z = \frac{\Delta V_Z}{\Delta I_Z}$$

When the device is programmed with two external resistors,  $R_1$  and  $R_2$ , (see *Figure 2*), the dynamic output impedance of the overall circuit,  $r_z$ , is defined as:

$$r_z = \frac{\Delta V_Z}{\Delta I_Z} \cong \left[ r_z \left( 1 + \frac{R_1}{R_2} \right) \right]$$



# Typical Performance Characteristics

Reference Voltage vs. Junction Temperature

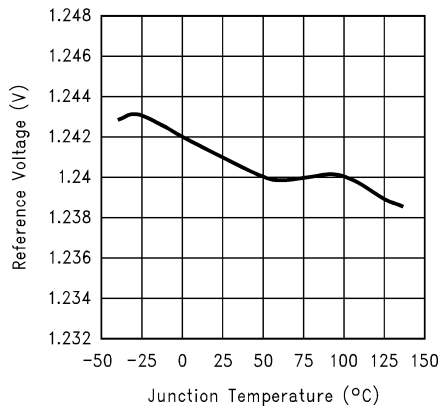

10095850

Reference Input Current vs. Junction Temperature

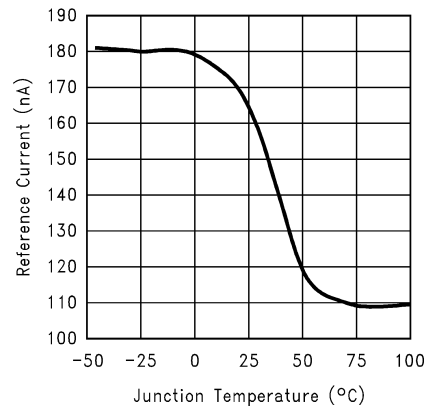

10095862

Cathode Current vs. Cathode Voltage 1

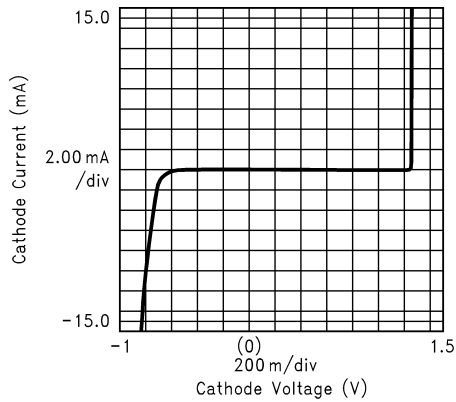

10095851

Cathode Current vs. Cathode Voltage 2

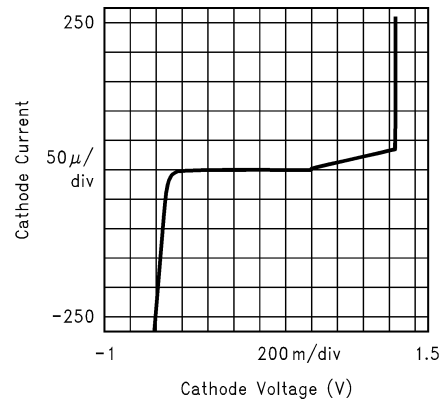

10095852

Off-State Cathode Current vs. Junction Temperature

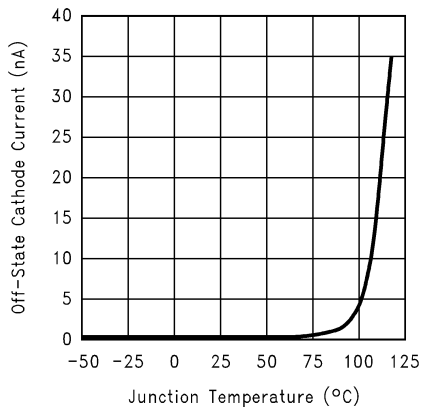

10095863

Delta Reference Voltage Per Delta Cathode Voltage vs. Junction Temperature

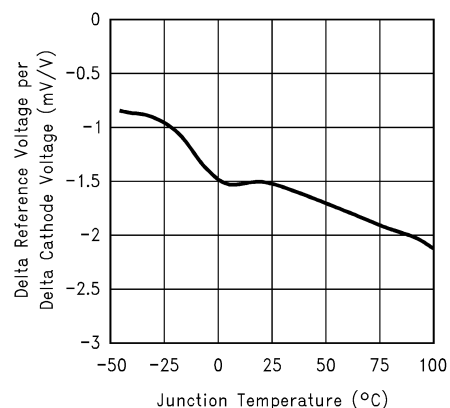

10095861

## Typical Performance Characteristics (Continued)

Input Voltage Noise vs. Frequency

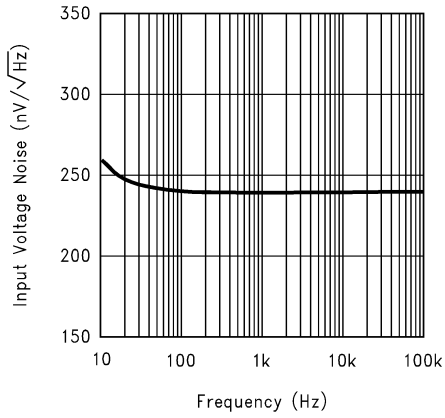

10095853

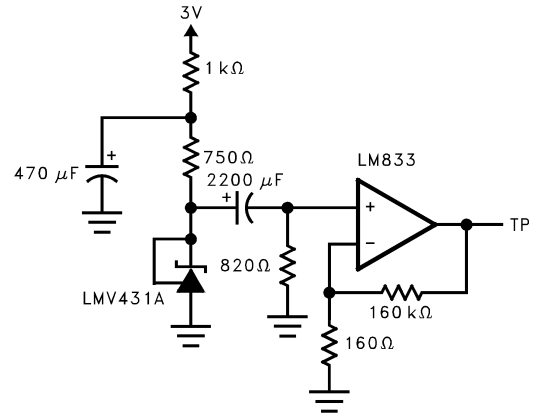

10095845

Test Circuit for Input Voltage Noise vs. Frequency

Low Frequency Peak to Peak Noise

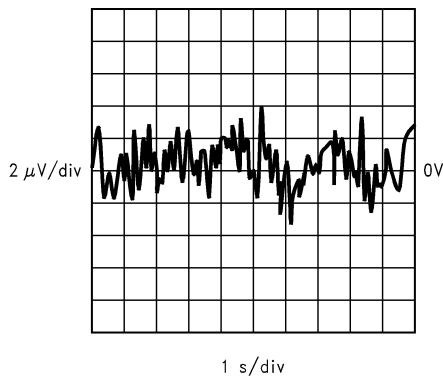

10095854

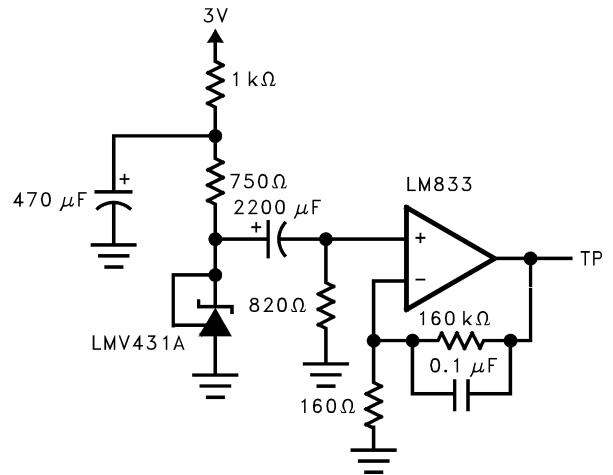

10095864

Test Circuit for Peak to Peak Noise (BW= 0.1Hz to 10Hz)

Small Signal Voltage Gain and Phase Shift vs. Frequency

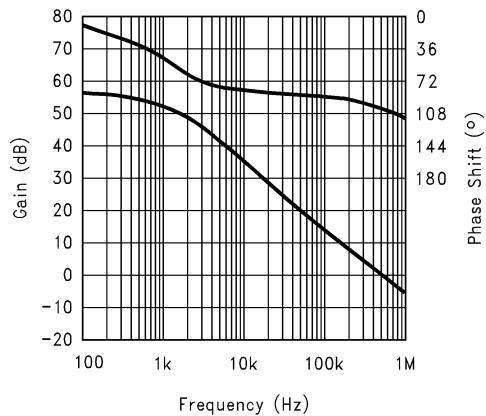

10095855

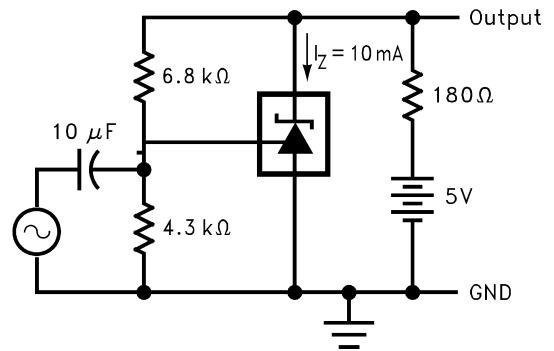

10095846

Test Circuit For Voltage Gain and Phase Shift vs. Frequency

## Typical Performance Characteristics (Continued)

Reference Impedance vs. Frequency

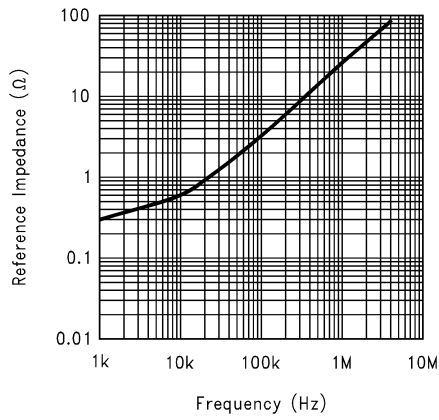

10095856

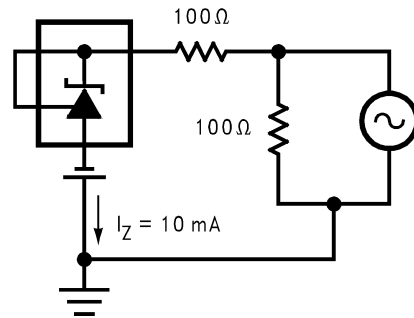

10095847

Test Circuit for Reference Impedance vs. Frequency

Pulse Response 1

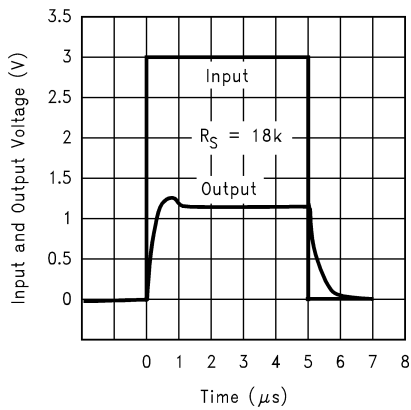

10095857

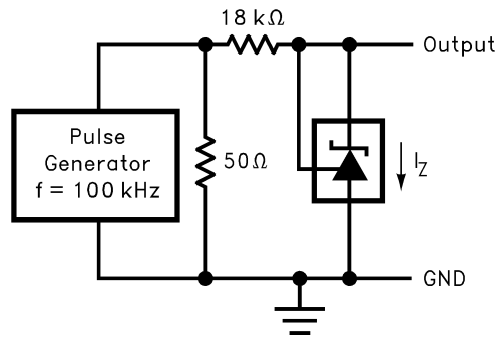

10095848

Test Circuit for Pulse Response 1

Pulse Response 2

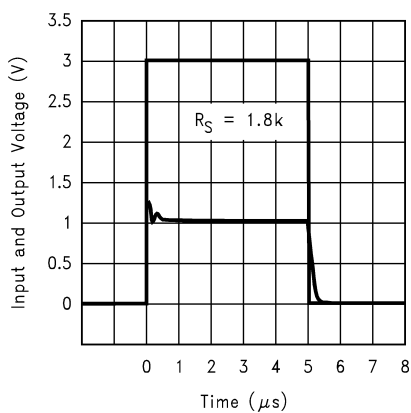

10095858

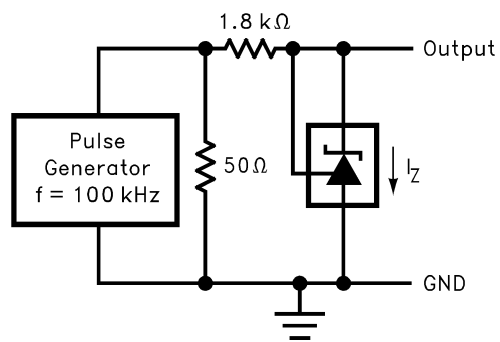

10095849

Test Circuit for Pulse Response 2

Typical Performance Characteristics (Continued)

LMV431 Stability Boundary Condition

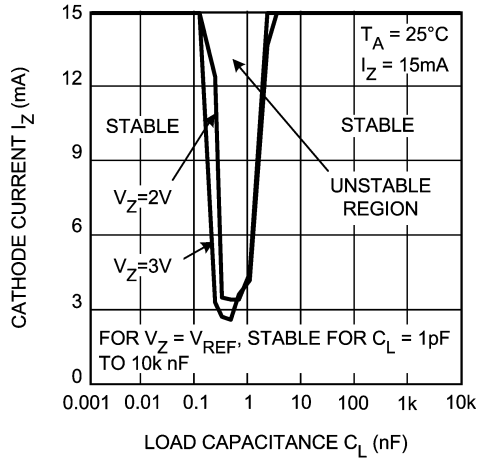

10095868

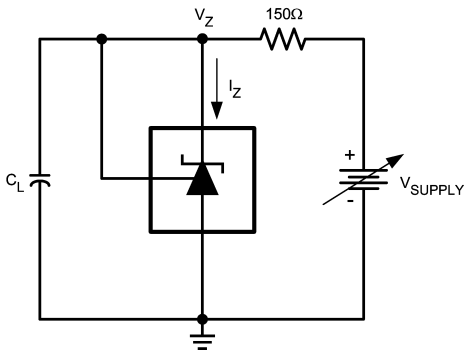

10095869

Test circuit for  $V_Z = V_{REF}$

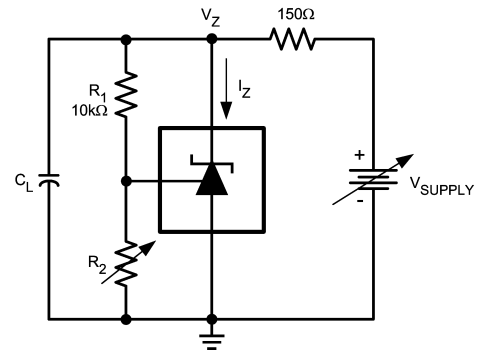

10095870

Test Circuit for  $V_Z = 2V, 3V$

Percentage Change in  $V_{REF}$  vs. Operating Life at 55°C

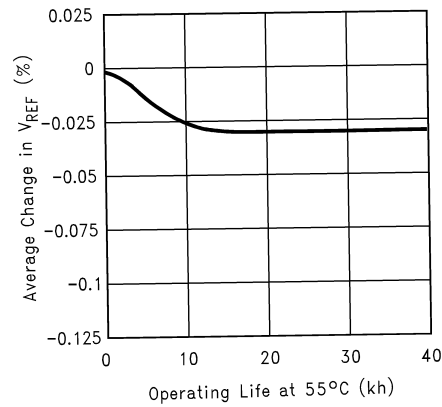

10095866

Extrapolated from life-test data taken at 125°C; the activation energy assumed is 0.7eV.

## Typical Applications

Series Regulator

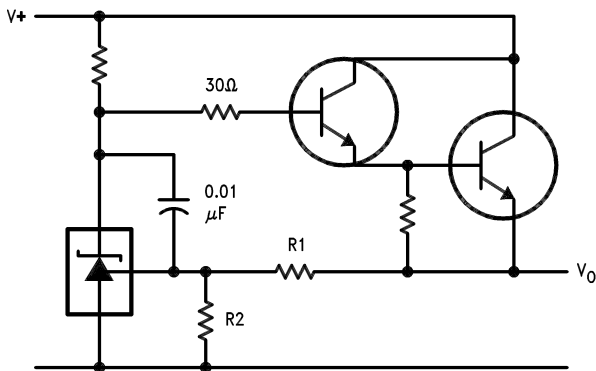

10095816

$$V_O \approx \left(1 + \frac{R_1}{R_2}\right) V_{REF}$$

Output Control of a Three Terminal Fixed Regulator

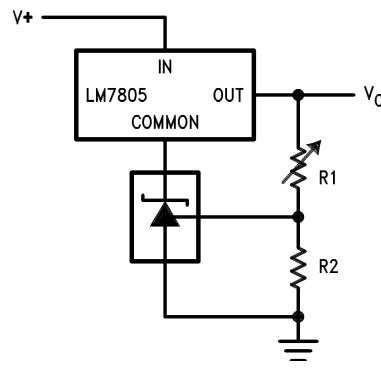

10095817

$$V_O = \left(1 + \frac{R_1}{R_2}\right) V_{REF}$$

$$V_{O\ MIN} = V_{REF} + 5V$$

Higher Current Shunt Regulator

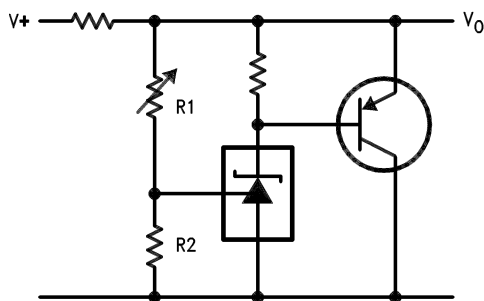

10095818

$$V_O \approx \left(1 + \frac{R_1}{R_2}\right) V_{REF}$$

Crow Bar

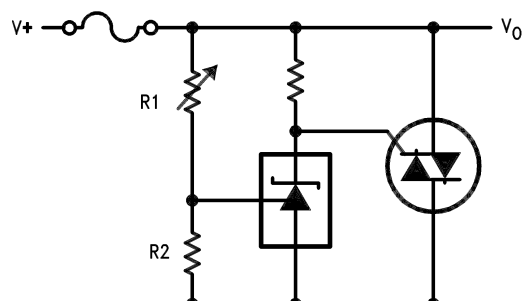

10095819

$$V_{LIMIT} \approx \left(1 + \frac{R_1}{R_2}\right) V_{REF}$$

Over Voltage/Under Voltage Protection Circuit

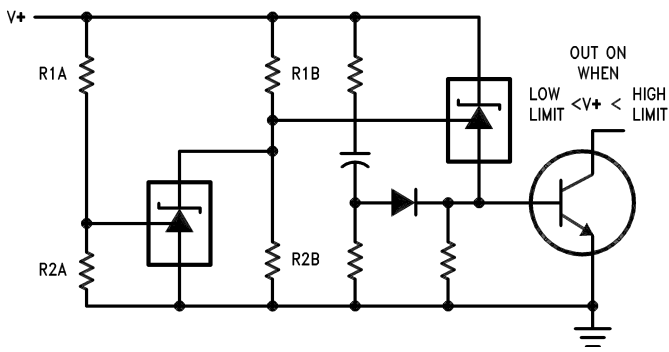

10095820

$$LOW\ LIMIT \approx V_{REF} \left(1 + \frac{R_{1B}}{R_{2B}}\right) + V_{BE}$$

$$HIGH\ LIMIT \approx V_{REF} \left(1 + \frac{R_{1A}}{R_{2A}}\right)$$

Voltage Monitor

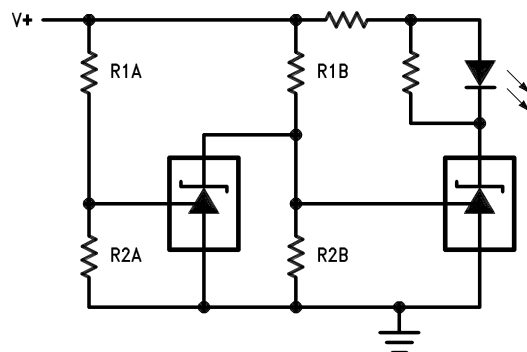

10095821

$$LOW\ LIMIT \approx V_{REF} \left(1 + \frac{R_{1B}}{R_{2B}}\right)$$

$$HIGH\ LIMIT \approx V_{REF} \left(1 + \frac{R_{1A}}{R_{2A}}\right)$$

LED ON WHEN  
LOW LIMIT < V+ < HIGH LIMIT

## Typical Applications (Continued)

Delay Timer

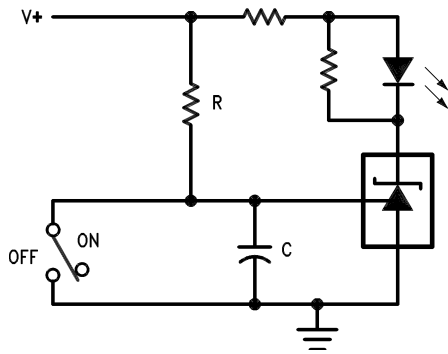

10095822

$$\text{DELAY} = R \cdot C \cdot \ln \frac{V^+}{(V^+) - V_{\text{REF}}}$$

Current Limiter or Current Source

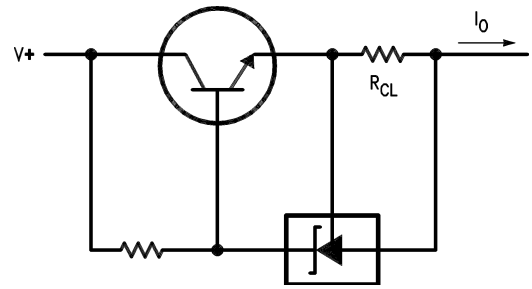

10095823

$$I_o = \frac{V_{\text{REF}}}{R_{\text{CL}}}$$

Constant Current Sink

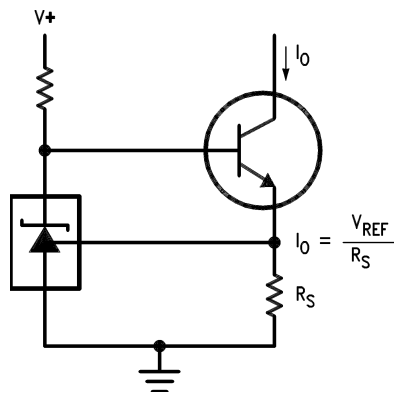

10095824

$$I_o = \frac{V_{\text{REF}}}{R_S}$$

**Physical Dimensions** inches (millimeters) unless otherwise noted

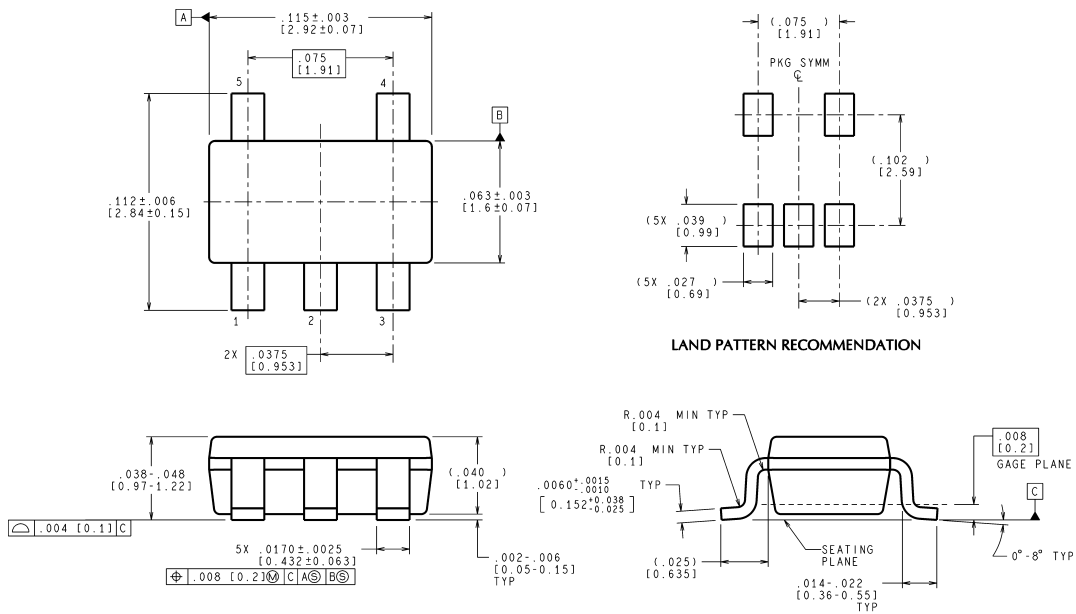

MF05A (Rev B)

**SOT23-5 Molded Small Outline Transistor Package (M5)**  
**NS Package Number MF05A**

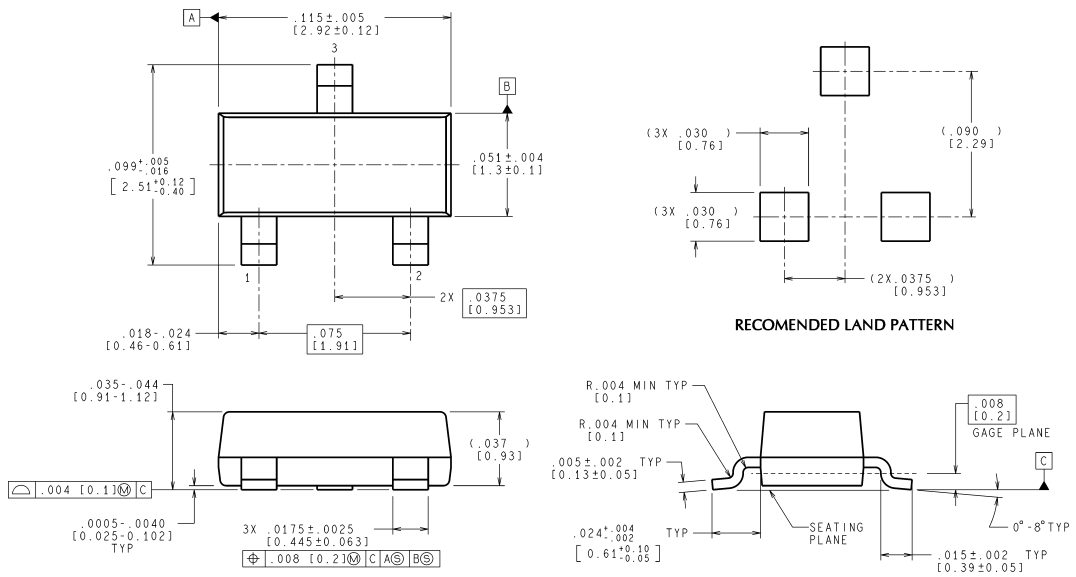

MF03A (Rev B)

**SOT23-3 Molded Small Outline Transistor Package (M3)**  
**NS Package Number MF03A**

**Physical Dimensions** inches (millimeters) unless otherwise noted (Continued)

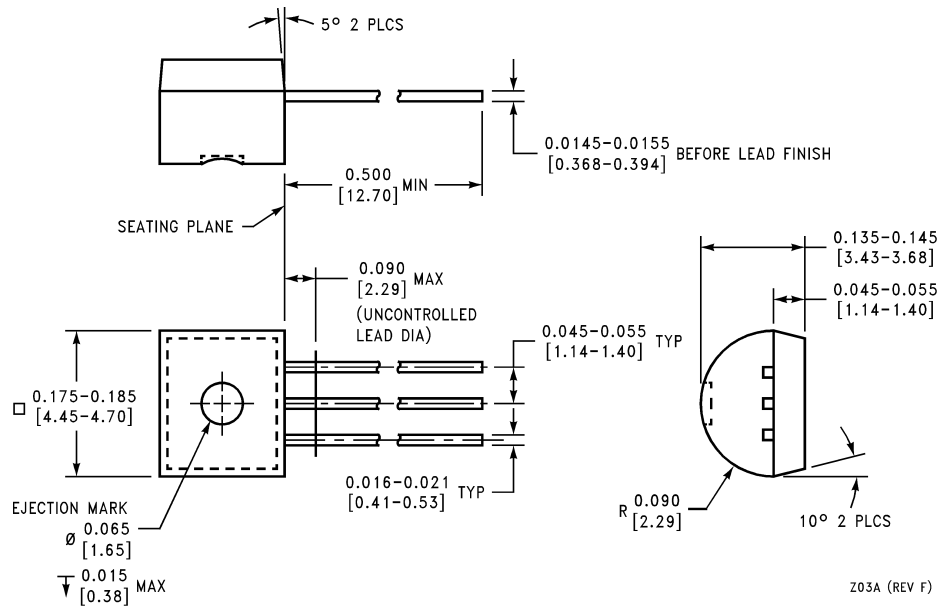

**TO-92 Plastic Package  
NS Package Number Z03A**

Z03A (REV F)

**LIFE SUPPORT POLICY**

NATIONAL'S PRODUCTS ARE NOT AUTHORIZED FOR USE AS CRITICAL COMPONENTS IN LIFE SUPPORT DEVICES OR SYSTEMS WITHOUT THE EXPRESS WRITTEN APPROVAL OF THE PRESIDENT AND GENERAL COUNSEL OF NATIONAL SEMICONDUCTOR CORPORATION. As used herein:

1. Life support devices or systems are devices or systems which, (a) are intended for surgical implant into the body, or (b) support or sustain life, and whose failure to perform when properly used in accordance with instructions for use provided in the labeling, can be reasonably expected to result in a significant injury to the user.
2. A critical component is any component of a life support device or system whose failure to perform can be reasonably expected to cause the failure of the life support device or system, or to affect its safety or effectiveness.



**National Semiconductor**  
Americas Customer  
Support Center  
Email: new.feedback@nsc.com  
Tel: 1-800-272-9959

**National Semiconductor**  
Europe Customer Support Center  
Fax: +49 (0) 180-530 85 86  
Email: europe.support@nsc.com  
Deutsch Tel: +49 (0) 69 9508 6208  
English Tel: +44 (0) 870 24 0 2171  
Français Tel: +33 (0) 1 41 91 8790

**National Semiconductor**  
Asia Pacific Customer  
Support Center  
Email: ap.support@nsc.com

**National Semiconductor**  
Japan Customer Support Center  
Fax: 81-3-5639-7507  
Email: jpn.feedback@nsc.com  
Tel: 81-3-5639-7560

www.national.com