



# SP691A/693A/800L/800M

## Low Power Microprocessor Supervisory with Battery Switch-Over

### FEATURES

- Precision 4.65V/4.40V Voltage Monitoring
- 200ms Or Adjustable Reset Time
- 100ms, 1.6s Or Adjustable Watchdog Time
- 60µA Maximum Operating Supply Current
- 2.0µA Maximum Battery Backup Current
- 0.1µA Maximum Battery Standby Current
- Power Switching
  - 250mA Output in Vcc Mode (0.6Ω)
  - 25mA Output in Battery Mode (5Ω)
- On-Board Gating of Chip-Enable Signals
  - Memory Write-Cycle Completion
  - 6ns CE Gate Propagation Delay
- Voltage Monitor for Power-Fail or Low Battery
- Backup-Battery Monitor
- RESET Valid to Vcc=1V
- 1% Accuracy Guaranteed (**SP800L/800M**)
- Pin Compatible Upgrade to MAX691A/693A/800L/800M

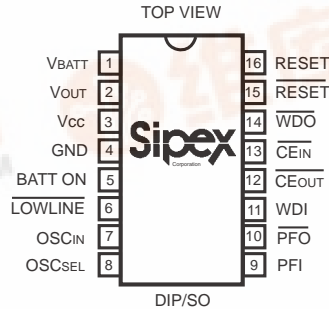

Now Available in Lead Free Packaging

### DESCRIPTION

The **SP691A/693A/800L/800M** is a microprocessor (µP) supervisory circuit that integrates a myriad of components involved in discrete solutions to monitor power-supply and battery-control functions in µP and digital systems. The **SP691A/693A/800L/800M** offers complete µP monitoring and watchdog functions. The **SP691A/693A/800L/800M** is ideal for a low-cost battery management solution and is well suited for portable, battery-powered applications with its supply current of 35µA. The 6ns chip-enable propagation delay, the 25mA current output in battery-backup mode, and the 250mA current output in standard operation also makes the **SP691A/693A/800L/800M** suitable for larger scale, high-performance equipment.

| Part Number | RESET Threshold | RESET Accuracy | PFI Accuracy | Backup-Battery Switch |
|-------------|-----------------|----------------|--------------|-----------------------|
| SP691A      | 4.65V           | ±125mV         | ±4%          | YES                   |
| SP693A      | 4.40V           | ±125mV         | ±4%          | YES                   |
| SP800L      | 4.65V           | ±50mV          | ±1%          | YES                   |
| SP800M      | 4.40V           | ±50mV          | ±1%          | YES                   |



## ABSOLUTE MAXIMUM RATINGS

These are stress ratings only and functional operation of the device at these ratings or any other above those indicated in the operation sections of the specifications below is not implied. Exposure to absolute maximum rating conditions for extended periods of time may affect reliability.

Terminal Voltages (with respect to GND)  
 $V_{CC}$ .....-0.3V to +6V  
 $V_{BATT}$ .....-0.3V to +6V  
 All Other Inputs.....-0.3V to ( $V_{CC}$  +0.3V)

Input Currents  
 $V_{CC}$  Peak.....1.0A  
 $V_{CC}$  Continuous.....250mA  
 $V_{BATT}$  Peak.....250mA  
 $V_{BATT}$  Continuous.....25mA  
 GND, BATT ON.....100mA  
 All Other Inputs.....25mA

Enhanced ESD Specifications.....±4kV Human Body Model

Power Dissipation Per Package  
 16-pin PDIP (derate 14.3mW/°C above +70°C).....1150mW  
 16-pin Narrow SOIC (derate 13.6mW/°C above 70°C).....1090mW  
 16-pin Wide SOIC (derate 11.2mW/°C above 70°C).....900mW

Storage Temperature.....-65°C to +150°C  
 Lead Temperature (soldering, 10 sec).....+300°C

## ELECTRICAL CHARACTERISTICS

$V_{CC}$  = +4.75V to +5.5V for the **SP691A/800L**,  $V_{CC}$  = +4.5V to +5.5V for the **SP693A/800M**,  $V_{BATT}$  = +2.8V, and  $T_{AMB}$  =  $T_{MIN}$  to  $T_{MAX}$  unless otherwise noted. Typical values apply at  $T_{AMB}$  = +25°C.

| PARAMETERS   | MIN.  | TYP.  | MAX.           | UNITS    | CONDITIONS  |
|--|---|---|----------------|----------|---|
| Operating Voltage Range,<br>$V_{CC}$ or $V_{BATT}$ , NOTE 1    | 0   |   | 5.5            | V        |   |
| Output Voltage, $V_{OUT}$<br>in Normal Operating Mode          | $V_{CC}$ -0.05<br>$V_{CC}$ -0.3<br>$V_{CC}$ -0.2        | $V_{CC}$ -0.015<br>$V_{CC}$ -0.15<br>$V_{CC}$ -0.09     |                | V        | $V_{CC}$ =4.5V, $I_{OUT}$ =25mA<br>$V_{CC}$ =4.5V, $I_{OUT}$ =250mA<br>$V_{CC}$ =3.0V, $V_{BATT}$ =2.8V, $I_{OUT}$ =100mA |
| $V_{CC}$ -to- $V_{OUT}$ On-Resistance                          |   | 0.6<br>0.9  | 1.2<br>2.0     | $\Omega$ | $V_{CC}$ =4.5V<br>$V_{CC}$ =3.0V  |
| $V_{OUT}$ in Battery-Backup Mode                               | $V_{BATT}$ -0.3<br>$V_{BATT}$ -0.25<br>$V_{BATT}$ -0.15 | $V_{BATT}$ -0.1<br>$V_{BATT}$ -0.07<br>$V_{BATT}$ -0.05 |                | V        | $V_{BATT}$ =4.5V, $I_{OUT}$ =20mA<br>$V_{BATT}$ =2.8V, $I_{OUT}$ =10mA<br>$V_{BATT}$ =2.0V, $I_{OUT}$ =5mA                |
| $V_{BATT}$ -to- $V_{OUT}$ On-Resistance                        |   | 5<br>7<br>10  | 15<br>25<br>30 | $\Omega$ | $V_{BATT}$ =4.5V<br>$V_{BATT}$ =2.8V<br>$V_{BATT}$ =2.0V  |
| Supply Current in Normal<br>Operating Mode, $I_{VCC}$          |   | 35  | 60             | $\mu$ A  | $V_{CC}$ >( $V_{BATT}$ -1V), excluding $I_{OUT}$  |
| Supply Current in Battery-<br>Backup Mode, $I_{BATT}$ , NOTE 2 |   | 0.001   | 2.0            | $\mu$ A  | $V_{CC}$ <( $V_{BATT}$ -1.2V), $V_{BATT}$ =2.8V, excluding $I_{OUT}$  |
| $V_{BATT}$ Standby Current, $I_{BATT}$ ,<br>NOTE 3             | -0.1  |   | 0.02           | $\mu$ A  | $V_{CC}$ ≥( $V_{BATT}$ +0.2V), excluding $I_{OUT}$  |
| Battery Switchover Threshold                                   |   | $V_{BATT}$ +0.03<br>$V_{BATT}$ -0.03                    |                | V        | power-up<br>power-down  |
| Battery Switchover Hysteresis                                  |   | 60  |                | mV       | Peak to Peak  |

## ELECTRICAL CHARACTERISTICS

$V_{CC} = +4.75V$  to  $+5.5V$  for the **SP691A/800L**,  $V_{CC} = +4.5V$  to  $+5.5V$  for the **SP693A/800M**,  $V_{BATT} = +2.8V$ , and  $T_{AMB} = T_{MIN}$  to  $T_{MAX}$  unless otherwise noted. Typical values apply at  $T_{AMB} = +25^{\circ}C$ .

| PARAMETERS   | MIN.                         | TYP.                         | MAX.                         | UNITS         | CONDITIONS   |
|--|------------------------------|------------------------------|------------------------------|---------------|--|
| BATT ON Output Low Voltage                                 |                              | 0.1<br>0.7                   | 0.4<br>1.5                   | V             | $I_{SINK}=3.2mA$<br>$I_{SINK}=25mA$  |
| BATT ON Output Short Circuit Current                       | 1                            | 60<br>15                     | 100                          | mA<br>$\mu A$ | sink current<br>source current   |
| <b>RESET, LOWLINE, AND WATCHDOG TIMER</b>                  |                              |                              |                              |               |  |
| Reset Threshold Voltage                                    | 4.50<br>4.25<br>4.60<br>4.35 | 4.65<br>4.40<br>4.65<br>4.40 | 4.75<br>4.50<br>4.70<br>4.45 | V             | <b>SP691A</b><br><b>SP693A</b><br><b>SP800L</b><br><b>SP800M</b>   |
| Reset Threshold Hysteresis                                 |                              | 15                           |                              | mV            | center-to-peak   |
| $V_{CC}$ to $\overline{RESET}$ Delay                       |                              | 80                           |                              | $\mu s$       | power down   |
| $\overline{LOWLINE}$ to $\overline{RESET}$ Delay           |                              | 800                          |                              | ns            | power down   |
| Reset Active Timeout Period for the Internal Oscillator    | 140                          | 200                          | 280                          | ms            | power-up   |
| Reset Active Timeout Period for the External Clock, NOTE 4 |                              | 2048                         |                              | clock cycles  | power-up   |
| Watchdog Timeout Period for the Internal Oscillator        | 1.0<br>70                    | 1.6<br>100                   | 2.25<br>140                  | sec<br>ms     | long period<br>short period  |
| Watchdog Timeout Period for the External Clock, NOTE 4     |                              | 4096<br>1024                 |                              | clock cycles  | long period<br>short period  |
| Minimum Watchdog Input Pulse Width                         | 100                          |                              |                              | ns            | $V_{IL}=0.8V, V_{IH}=0.75xV_{CC}$  |
| $\overline{RESET}$ Output Voltage                          | 3.5                          | 0.004<br>0.1                 | 0.3<br>0.4                   | V             | $I_{SINK}=50\mu A, V_{CC}=1V, V_{CC}$ falling<br>$I_{SINK}=3.2mA, V_{CC}=4.25V$<br>$I_{SOURCE}=1.6mA, V_{CC}=5V$ |
| $\overline{RESET}$ Output Short-Circuit Current            |                              | 7                            | 20                           | mA            | output source current  |
| $\overline{RESET}$ Output Voltage Low, NOTE 5              |                              | 0.1                          | 0.4                          | V             | $I_{SINK}=3.2mA$   |
| $\overline{LOWLINE}$ Output Voltage                        | 3.5                          | 0.1                          | 0.4                          | V             | $I_{SINK}=3.2mA, V_{CC}=4.25V$<br>$I_{SOURCE}=1\mu A, V_{CC}=5V$   |
| $\overline{LOWLINE}$ Output Short Circuit Current          |                              | 15                           | 100                          | $\mu A$       | output source current  |
| $\overline{WDO}$ Output Voltage                            | 3.5                          | 0.1                          | 0.4                          | V             | $I_{SINK}=3.2mA$<br>$I_{SOURCE}=500\mu A, V_{CC}=5V$   |
| $\overline{WDO}$ Output Short-Circuit Current              |                              | 3                            | 10                           | mA            | output source current  |

## ELECTRICAL CHARACTERISTICS

$V_{CC} = +4.75V$  to  $+5.5V$  for the **SP691A/800L**,  $V_{CC} = +4.5V$  to  $+5.5V$  for the **SP693A/800M**,  $V_{BATT} = +2.8V$ , and  $T_{AMB} = T_{MIN}$  to  $T_{MAX}$  unless otherwise noted. Typical values apply at  $T_{AMB} = +25^{\circ}C$ .

| PARAMETERS   | MIN.                 | TYP.                  | MAX.           | UNITS         | CONDITIONS   |
|--|----------------------|-----------------------|----------------|---------------|--|
| WDI Threshold Voltage,<br>NOTE 6   | $0.75 \times V_{CC}$ |                       | 0.8            | V             | $V_{IH}$<br>$V_{IL}$   |
| WDI Input Current  | -50                  | -10<br>20             | 50             | $\mu A$       | WDI=0V<br>WDI= $V_{OUT}$   |
| <b>POWER-FAIL COMPARATOR</b>   |                      |                       |                |               |  |
| PFI Input Threshold  | 1.237<br>1.225       | 1.25<br>1.25          | 1.263<br>1.275 | V             | <b>SP691A/693A</b> , $V_{CC}=5V$<br><b>SP800L/800M</b> , $V_{CC}=5V$                 |
| PFI Leakage Current  |                      | $\pm 0.01$            | $\pm 25$       | nA            |  |
| PFO Output Voltage   | 3.5                  | 0.1                   | 0.4            | V             | $I_{SINK}=3.2mA$<br>$I_{SOURCE}=1\mu A$ , $V_{CC}=5V$                                |
| PFO Short Circuit Current  | 1                    | 60<br>15              | 100            | mA<br>$\mu A$ | output sink current<br>output source current   |
| PFI-to-PFO Delay   |                      | 25<br>60              |                | $\mu s$       | $V_{OD}=15mV$<br>$V_{OD}=15mV$   |
| <b>CHIP-ENABLE GATING</b>  |                      |                       |                |               |  |
| $\overline{CE}_{IN}$ Leakage Current                                       |                      | $\pm 0.005$           | $\pm 1$        | $\mu A$       | disable mode   |
| $\overline{CE}_{IN}$ to $\overline{CE}_{OUT}$ Resistance,<br>NOTE 7        |                      | 65                    | 150            | $\Omega$      | enable mode  |
| $\overline{CE}_{OUT}$ Short-Circuit Current<br>(RESET Active)              | 0.1                  | 0.75                  | 2.0            | mA            | disable mode, $\overline{CE}_{OUT}=0V$   |
| $\overline{CE}_{IN}$ to $\overline{CE}_{OUT}$ Propagation<br>Delay, NOTE 8 |                      | 6                     | 10             | ns            | $50\Omega$ source impedance driver, $C_{LOAD}=50pF$                                  |
| $\overline{CE}_{OUT}$ Output Voltage High<br>(RESET Active)                | 3.5<br>2.7           |                       |                | V             | $V_{CC}=5V$ , $I_{OUT}=100\mu A$<br>$V_{CC}=0V$ , $V_{BATT}=2.8V$ , $I_{OUT}=1\mu A$ |
| RESET to $\overline{CE}_{OUT}$ Delay                                       |                      | 12                    |                | $\mu s$       | power-down   |
| <b>INTERNAL OSCILLATOR</b>   |                      |                       |                |               |  |
| $OSC_{IN}$ Leakage Current   |                      | 0.10                  | $\pm 5.0$      | $\mu A$       | $OSC_{SEL}=0V$   |
| $OSC_{IN}$ Input Pull-Up Current   |                      | 10                    | 100            | $\mu A$       | $OSC_{SEL}=V_{OUT}$ or floating, $OSC_{IN}=0V$                                       |
| $OSC_{SEL}$ Input Pull-Up Current  |                      | 10                    | 100            | $\mu A$       | $OSC_{SEL}=0V$   |
| $OSC_{IN}$ Frequency Range   |                      | 200                   |                | kHz           | $OSC_{SEL}=0V$   |
| $OSC_{IN}$ External Oscillator<br>Threshold Voltage                        | $V_{OUT}-0.3$        | $V_{OUT}-0.6$<br>3.65 | 2.0            | V             | $V_{IH}$<br>$V_{IL}$   |
| $OSC_{IN}$ Frequency with<br>External Capacitor                            |                      | 2                     |                | kHz           | $OSC_{SEL}=0V$ , $C_{OSC}=47pF$  |

## ELECTRICAL CHARACTERISTICS

$V_{CC} = +4.75V$  to  $+5.5V$  for the **SP691A/800L**,  $V_{CC} = +4.5V$  to  $+5.5V$  for the **SP693A/800M**,  $V_{BATT} = +2.8V$ , and  $T_{AMB} = T_{MIN}$  to  $T_{MAX}$  unless otherwise noted. Typical values apply at  $T_{AMB} = +25^{\circ}C$ .

NOTE 1: Either  $V_{CC}$  or  $V_{BATT}$  can go to 0V, if the other is greater than 2.0V.

NOTE 2: The supply current drawn by the **SP691A/693A/800L/800M** from the battery (excluding  $I_{OUT}$ ) typically goes to  $5\mu A$  when  $(V_{BATT} - 1V) < V_{CC} < V_{BATT}$ . In most applications, this is a brief period as  $V_{CC}$  falls through this region.

NOTE 3: "+" = battery-discharging current, "-" = battery-charging current.

NOTE 4: Although presented as typical values, the number of clock cycles for the reset and watchdog timeout periods are fixed and do not vary with process or temperature.

NOTE 5: RESET is an open-drain output and sinks current only.

NOTE 6: WDI is internally connected to a voltage divider between  $V_{OUT}$  and GND. If unconnected, WDI is driven to 1.6V (typ), disabling the watchdog function.

NOTE 7: The chip-enable resistance is tested with  $V_{CC} = +4.75V$  for the **SP691A/800L** and  $V_{CC} = +4.5V$  for the **SP693A/800M**.  $CE_{IN} = CE_{OUT} = V_{CC}/2$ .

NOTE 8: The chip-enable propagation delay is measured from the 50% point at  $CE_{IN}$  to the 50% point at  $CE_{OUT}$ .

## TYPICAL PERFORMANCE CHARACTERISTICS

( $T_{AMB} = 25^{\circ}C$ , unless otherwise noted)

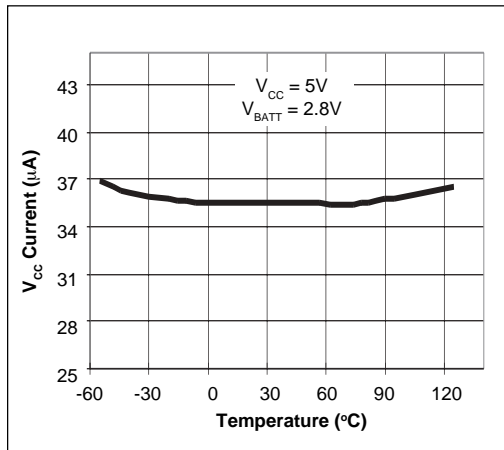

Figure 1.  $V_{CC}$  Supply Current vs. Temperature (Normal Operating Mode)

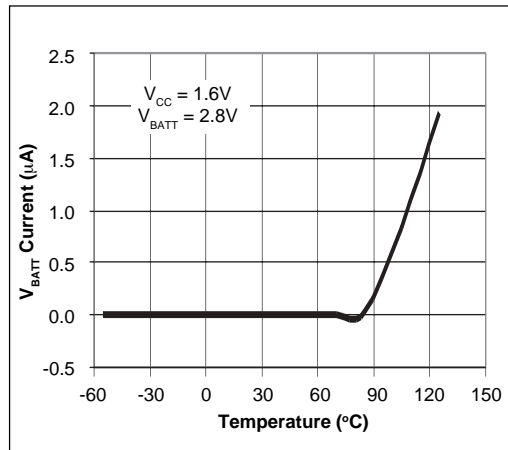

Figure 2. Battery Supply Current vs. Temperature (Battery-Backup Mode)

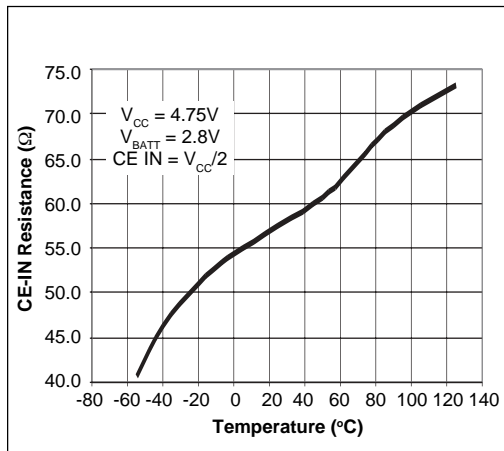

Figure 3. Chip-Enable On-Resistance vs. Temperature

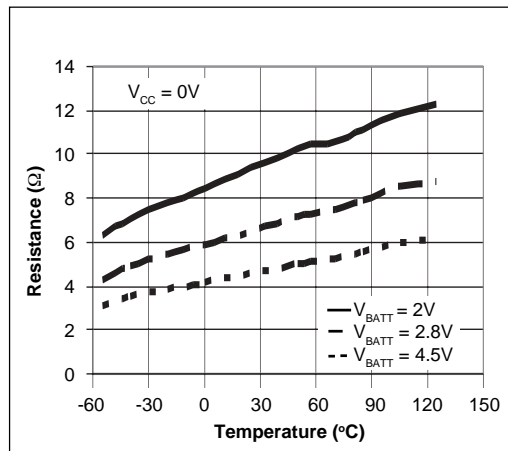

Figure 4.  $V_{BATT}$  to  $V_{OUT}$  On-Resistance vs. Temperature

## TYPICAL PERFORMANCE CHARACTERISTICS

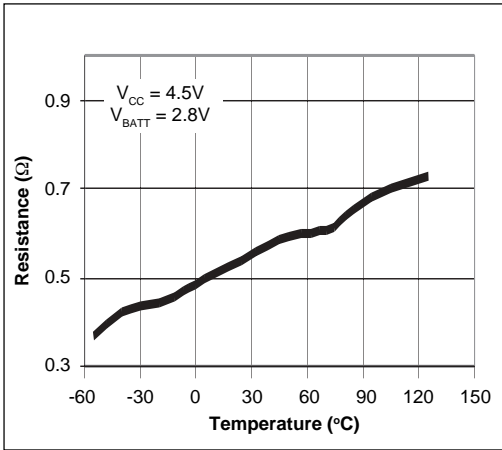

Figure 5.  $V_{CC}$  to  $V_{OUT}$  On-Resistance vs. Temperature

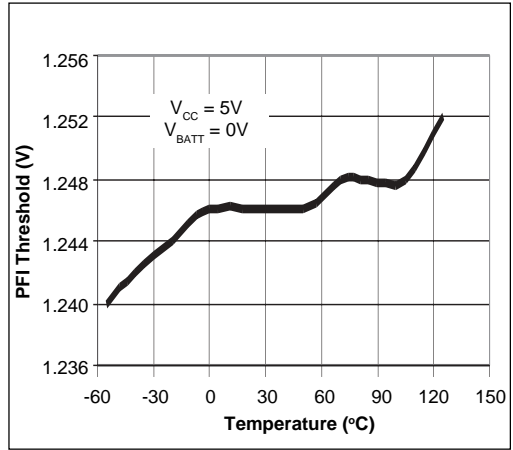

Figure 6. PFI Threshold vs. Temperature

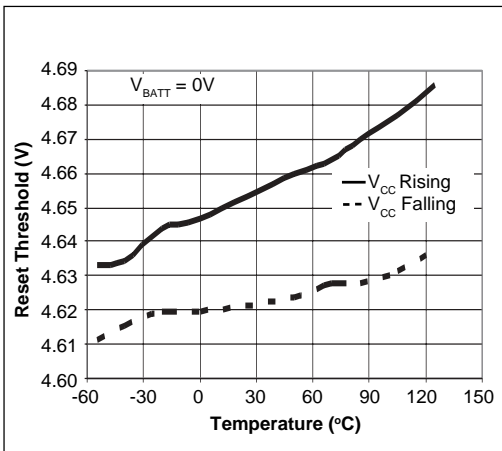

Figure 7. Reset Threshold vs. Temperature

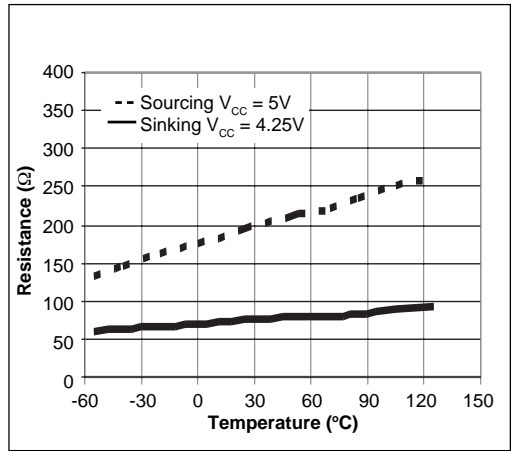

Figure 8. RESET Output Resistance vs. Temperature

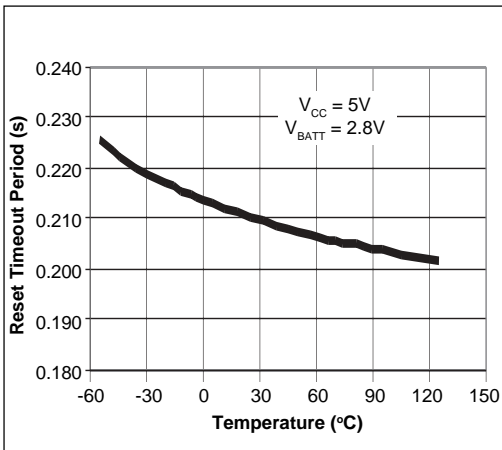

Figure 9. Reset Delay vs. Temperature

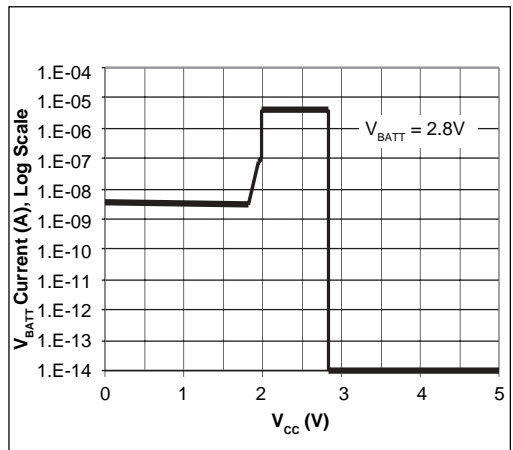

Figure 10. Battery Current vs. Input Supply Voltage

## TYPICAL PERFORMANCE CHARACTERISTICS

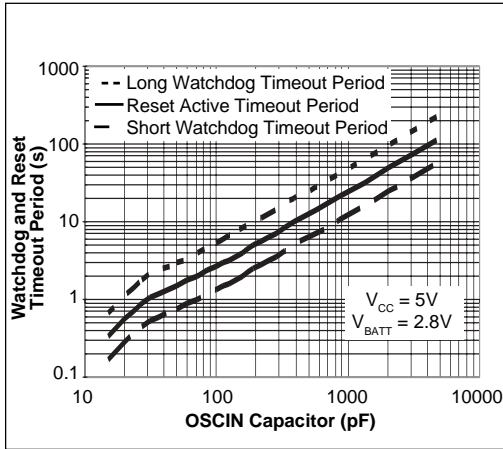

Figure 11. Watchdog and Reset Timeout Period vs.  $OSC_{IN}$  Timing Capacitor ( $C_{osc}$ )

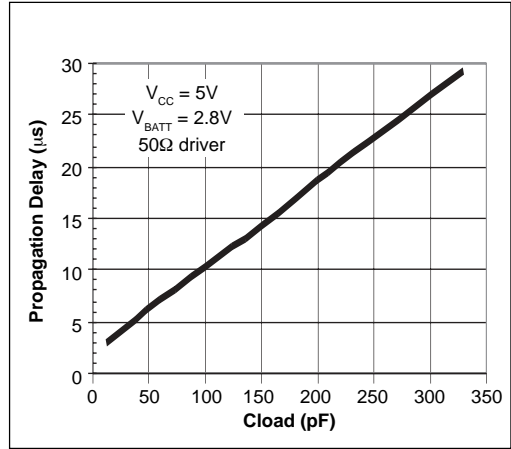

Figure 12. Chip-Enable Propagation Delay vs.  $\overline{CE}_{OUT}$  Load Capacitance

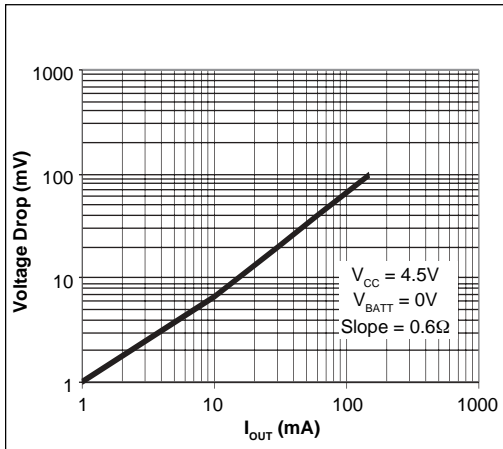

Figure 13.  $V_{CC}$  to  $V_{OUT}$  vs. Output Current (Normal Operating Mode)

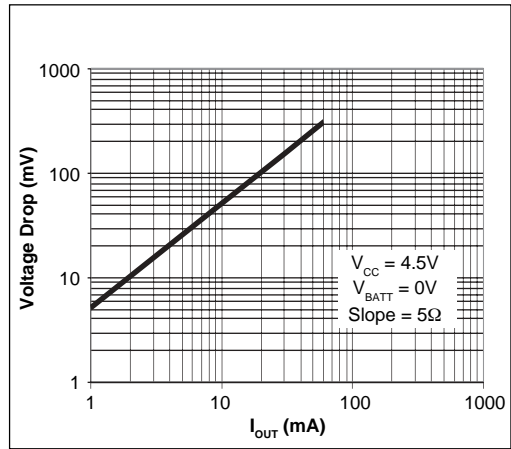

Figure 14.  $V_{BATT}$  to  $V_{OUT}$  vs. Output Current (Battery-Backup Mode)

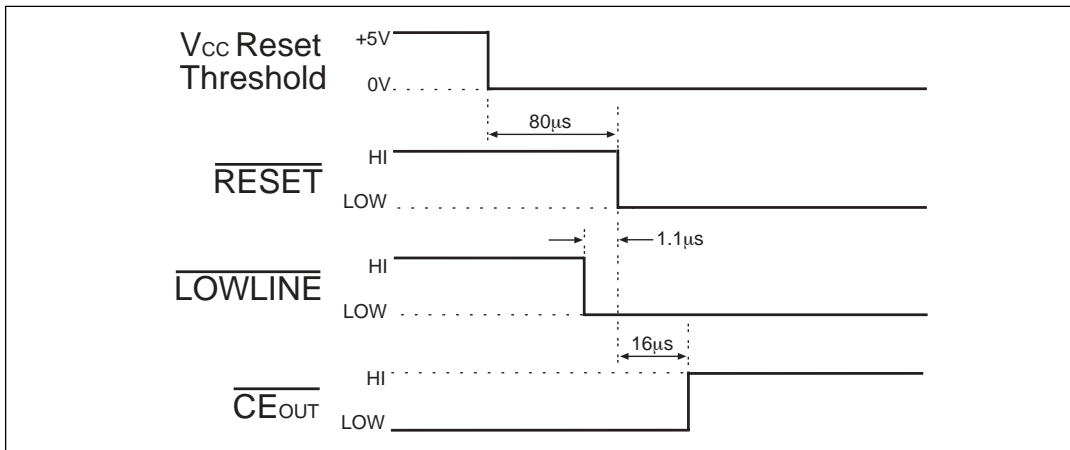
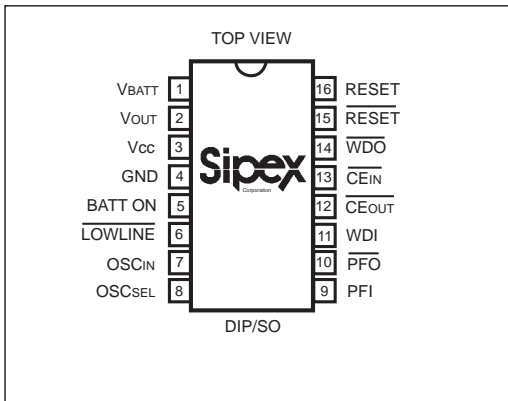

Figure 15.  $V_{CC}$  to  $\overline{LOWLINE}$  and  $\overline{CE}_{OUT}$  Delay

## PINOUT



## PIN ASSIGNMENTS

Pin 1 —  $V_{BATT}$  — Battery-Backup Input. Connect to the external battery supply or supercharging capacitor and charging circuit. If a backup battery is not provided, connect this pin to ground.

Pin 2 —  $V_{OUT}$  — Output Supply Voltage.  $V_{OUT}$  connects to  $V_{CC}$  when  $V_{CC}$  is greater than  $V_{BATT}$  and  $V_{CC}$  is above the reset threshold. When  $V_{CC}$  falls below  $V_{BATT}$  and  $V_{CC}$  is below the reset threshold,  $V_{OUT}$  connects to  $V_{BATT}$ . Connect a 0.1  $\mu\text{F}$  capacitor from  $V_{OUT}$  to GND.

Pin 3 —  $V_{CC}$  — +5V Input Supply Voltage.

Pin 4 — GND — Ground reference for all signals.

Pin 5 — BATT ON — Battery On Output. Goes high when  $V_{OUT}$  switches to  $V_{BATT}$ . Goes low when  $V_{OUT}$  switches to  $V_{CC}$ . Connect the base of a PNP through a current-limiting resistor to BATT ON for  $V_{OUT}$  current requirements greater than 250mA.

Pin 6 —  $\overline{\text{LOWLINE}}$  — Low Line Output. This output pin goes LOW when  $V_{CC}$  falls below the reset threshold voltage. This output pin returns to its HIGH output as soon as  $V_{CC}$  rises above the reset threshold voltage.

Pin 7 —  $\text{OSC}_{IN}$  — External Oscillator Input. When  $\text{OSC}_{SEL}$  is unconnected or driven HIGH, a 10  $\mu\text{A}$  pull-up connects from  $V_{OUT}$  to this input pin, the internal oscillator sets the reset and watchdog timeout periods, and this input pin selects between fast and slow watchdog timeout periods. When  $\text{OSC}_{SEL}$  is driven LOW, the reset and watchdog timeout periods may be set either by a capacitor from this input pin to ground or by an external clock at this pin (refer to *Figure 21*).

Pin 8 —  $\text{OSC}_{SEL}$  — Oscillator Select. When  $\text{OSC}_{SEL}$  is unconnected or driven HIGH, the internal oscillator sets the reset delay and watchdog timeout period. When  $\text{OSC}_{SEL}$  is driven LOW, the external oscillator input pin,  $\text{OSC}_{IN}$ , is enabled (refer to *Table 1*). This input pin has a 10  $\mu\text{A}$  internal pull-up.

Pin 9 — PFI — Power-Fail Input. This is the noninverting input to the power-fail comparator. When PFI is less than 1.25V,  $\overline{\text{PFO}}$  goes low. Connect PFI to GND or  $V_{OUT}$  when not used.

Pin 10 —  $\overline{\text{PFO}}$  — Power-Fail Output. This is the output of the power-fail comparator.  $\overline{\text{PFO}}$  goes low when PFI is less than 1.25V. This is an uncommitted comparator, and has no effect on any other internal circuitry.

Pin 11 — WDI — Watchdog Input. This is a three-level input pin. If WDI remains either HIGH or LOW for longer than the watchdog timeout period,  $\overline{\text{WDO}}$  goes LOW and RESET is asserted for the reset timeout period.  $\overline{\text{WDO}}$  remains LOW until the next transition at this input pin. Leaving this input pin unconnected disables the watchdog function. This input pin connects to an internal voltage divider between  $V_{OUT}$  and ground, which sets it to mid-supply when left unconnected.



Pin 12 —  $\overline{\text{CE}}_{\text{OUT}}$  — Chip-Enable Output. This output pin goes LOW only when  $\overline{\text{CE}}_{\text{IN}}$  is LOW and  $V_{\text{CC}}$  is above the reset threshold voltage. If  $\overline{\text{CE}}_{\text{IN}}$  is LOW when RESET is asserted, this output pin will stay low for 16 $\mu\text{s}$  or until  $\overline{\text{CE}}_{\text{IN}}$  goes HIGH, whichever occurs first.

Pin 13 —  $\overline{\text{CE}}_{\text{IN}}$  — Chip-Enable Input. This is the input pin to the chip-enable gating circuit. If this input pin is not used, connect it to ground or  $V_{\text{OUT}}$ .

Pin 14 —  $\overline{\text{WDO}}$  — Watchdog Output. If WDI remains HIGH or LOW longer than the watchdog timeout period, this output pin goes LOW and RESET is asserted for the reset timeout period. This output pin returns HIGH on the next transition at WDI. This output pin remains HIGH if WDI is unconnected.

Pin 15 —  $\overline{\text{RESET}}$  — Active LOW Reset Output. This output pin goes LOW whenever  $V_{\text{CC}}$  falls below the reset threshold. This output pin will remain low typically for 200ms after  $V_{\text{CC}}$  crosses the reset threshold voltage on power-up.

Pin 16 — RESET — Active HIGH Reset Output. This output pin is open drain and the inverse of  $\overline{\text{RESET}}$ .

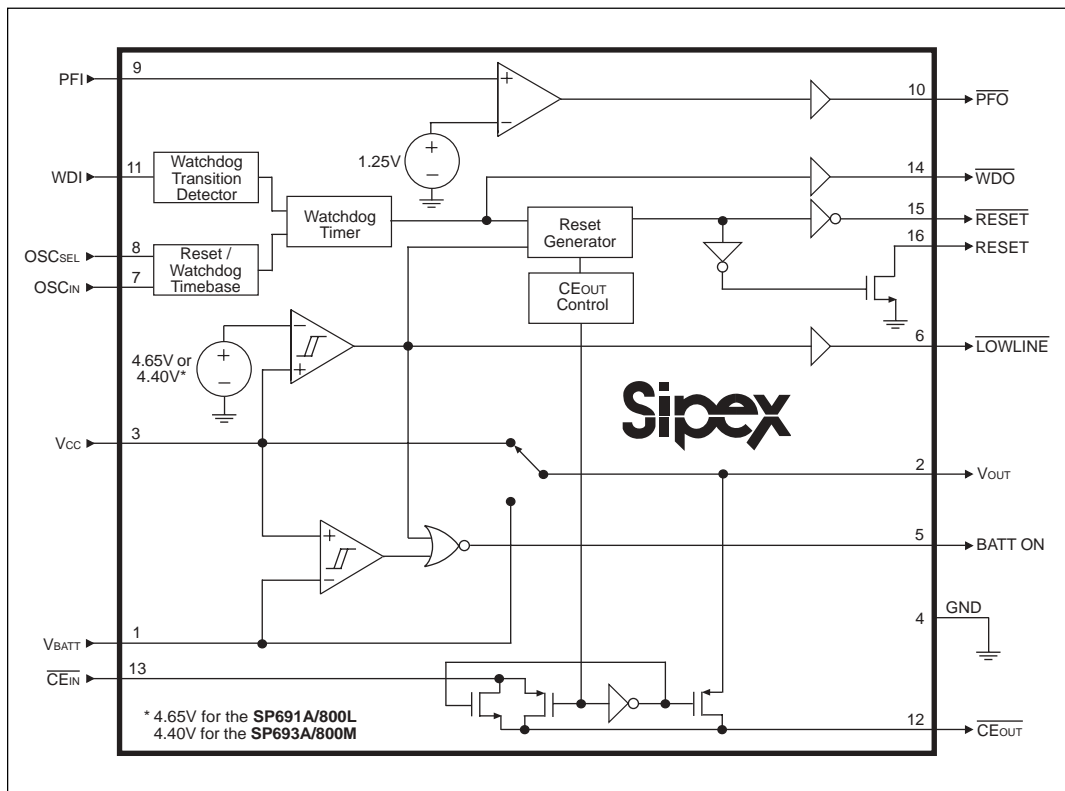

Figure 16. Internal Block Diagram of the SP691A/693A/800L/800M

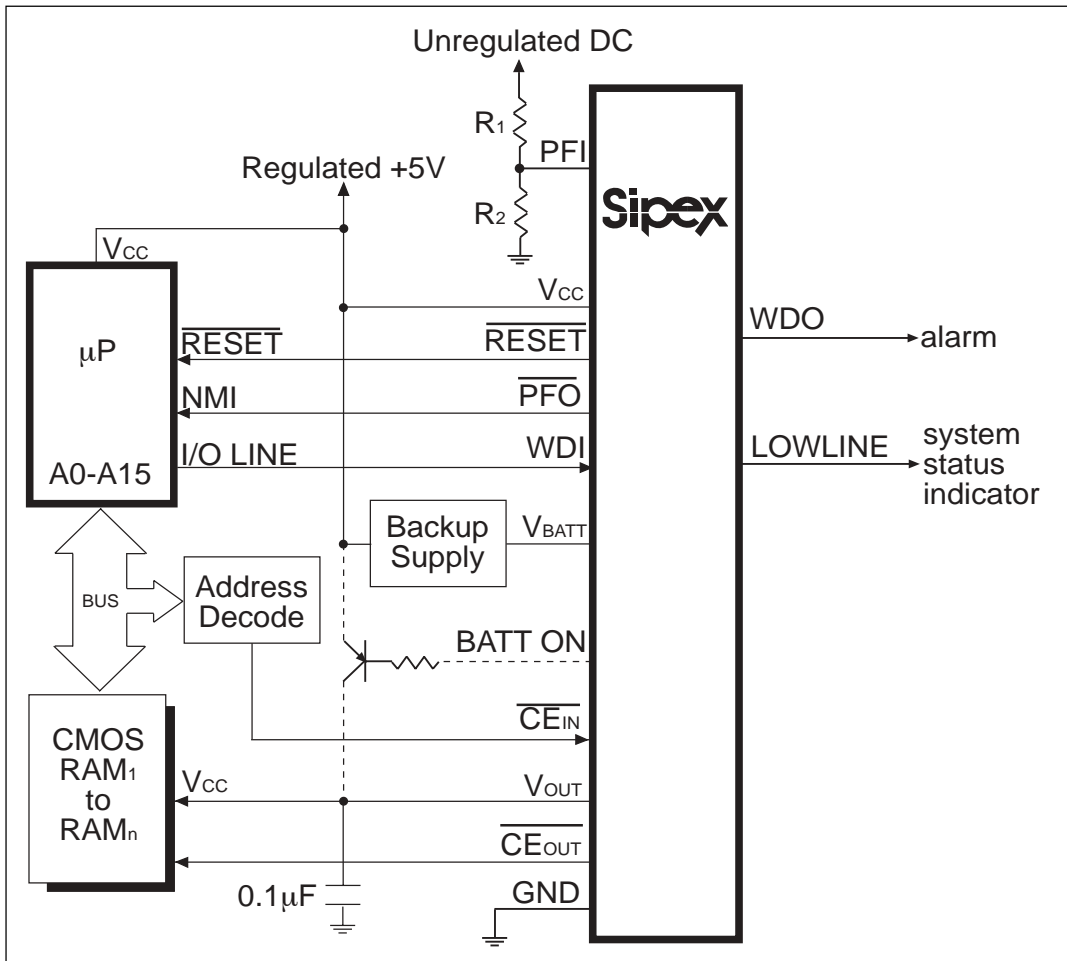

Figure 17. Typical Application Circuit of the SP691A/693A/800L/800M

## FEATURES

The **SP691A/693A/800L/800M** devices are microprocessor (μP) supervisory circuits that monitor the power supplied to digital circuits such as microprocessors, microcontrollers, or memory. The **SP691A/693A/800L/800M** series is an ideal solution for portable, battery-powered equipment that require power supply monitoring. The **SP691A/693A/800L/800M** watchdog functions will continuously oversee the operational status of a system. Implementing the **SP691A/693A/800L/800M** series will reduce the number of components and overall complexity in a design that requires power supply monitoring circuitry. The operational features and benefits of this series are described in more detail below.

## THEORY OF OPERATION

The **SP691A/693A/800L/800M** series is a complete μP supervisor IC and provides the following main functions:

- 1) μP reset ➔ Reset output is asserted during power fluxuations such as power-up, power-down, and brown out conditions, and is guaranteed to be in the correct state for VCC down to 1V, even with no battery in the circuit.
- 2) μP reset ➔ Reset output is pulsed if the optional watchdog timer has not been toggled within a specified time.
- 3) Power Fail Comparator ➔ Provides for power-fail warning and low-battery detection, or monitors another power supply.

- 4) Watchdog function → Monitors  $\mu\text{P}$  activity where the watchdog output goes to a logic LOW state if the watchdog input is not toggled for greater than the timeout period.
- 5) Internal switch → Switches over from  $V_{CC}$  to  $V_{BATT}$  if the  $V_{CC}$  falls below the reset threshold.

## RESET and RESET Outputs

The **SP691A/693A/800L/800M** devices' **RESET** and **RESET** outputs ensure that the  $\mu\text{P}$  powers up in a known state, and prevents code-execution errors during power-down or brownout conditions.

The **RESET** output is active low, and typically sinks 3.2mA at 0.1V saturation voltage in its active state. When deasserted, **RESET** sources 1.6mA at typically  $V_{OUT} - 0.5V$ . **RESET** output is open drain, active high, and typically sinks 3.2mA with a saturation voltage of 0.1V. When no backup battery is used, **RESET** output is guaranteed to be valid down to  $V_{CC} = 1V$ , and an external  $10k\Omega$  pull-down resistor on **RESET** ensures that **RESET** will be valid with  $V_{CC}$  down to GND as shown on *Figure 18*. As  $V_{CC}$  goes below 1V, the gate drive to the **RESET** output switch reduces accordingly, increasing the  $R_{DS(ON)}$  and the saturation voltage. The  $10k\Omega$  pull-down resistor ensures the parallel combination of switch plus resistor is around

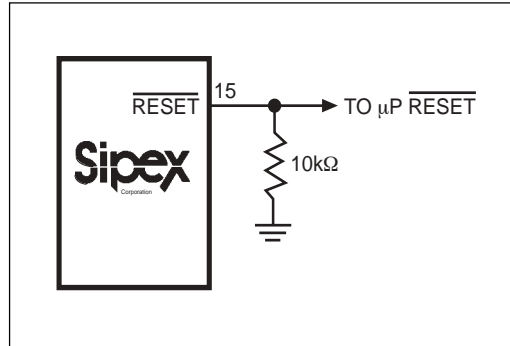

*Figure 18. External Pull-down Resistor Ensures RESET is Valid with  $V_{CC}$  Down to Ground.*

$10k\Omega$  and the output saturation voltage is below 0.4V while sinking  $40\mu\text{A}$ . When using a  $10k\Omega$  external pull-down resistor, the high state for the **RESET** output with  $V_{CC} = 4.75V$  is 4.5V typical. For battery voltages less than or equal to 2V connected to  $V_{BATT}$ , **RESET** and **RESET** remains valid for  $V_{CC}$  from 0V to 5.5V.

**RESET** and **RESET** are asserted when  $V_{CC}$  falls below the reset threshold and remain asserted for the Reset Timeout Period (200ms nominal) after  $V_{CC}$  rises above the reset threshold voltage on power-up. Refer to *Figure 19*. The devices' battery-switchover comparator does not affect reset assertion. However, both reset outputs are asserted in battery-backup mode since  $V_{CC}$  must be below the reset threshold to enter this mode.

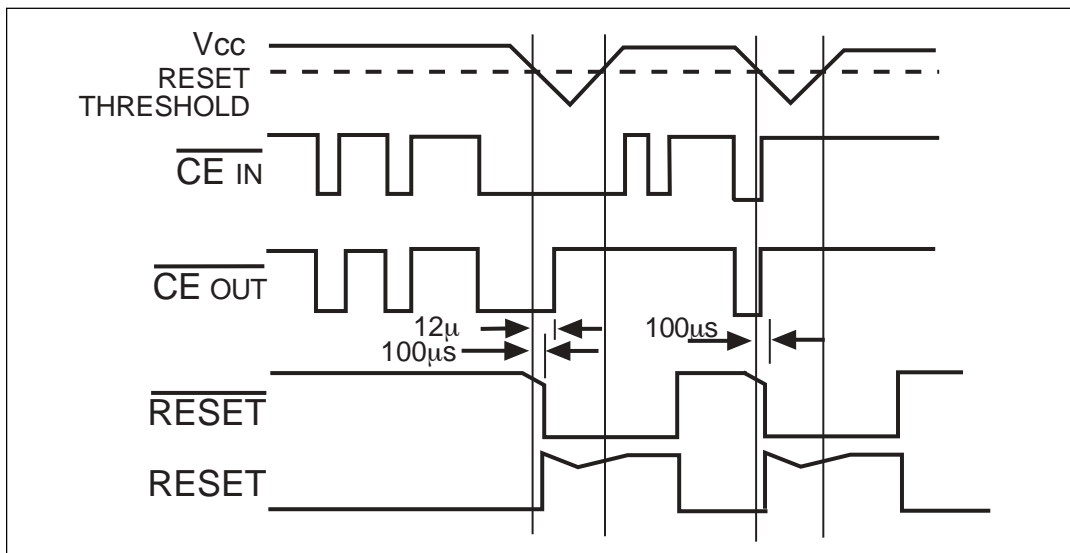

*Figure 19. Reset and CE In/Out Timing*

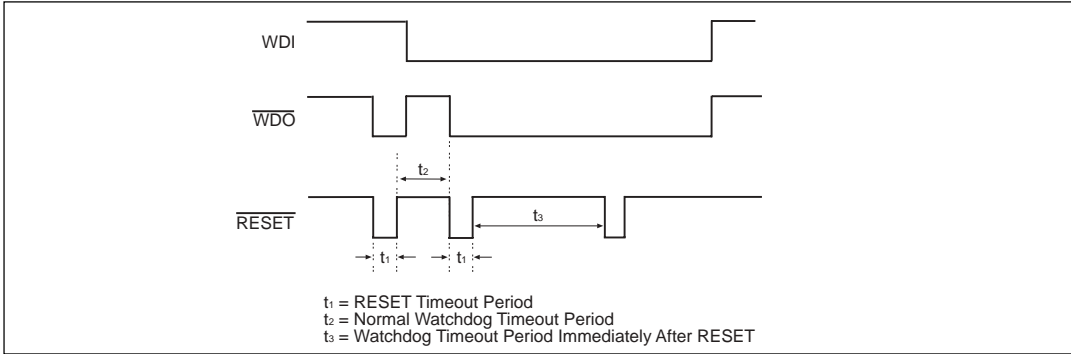

Figure 20. Watchdog Timeout Period and Reset Active Time

### Watchdog Function

The watchdog monitors  $\mu\text{P}$  activity via the Watchdog Input (WDI). If the  $\mu\text{P}$  becomes inactive,  $\overline{\text{RESET}}$  and RESET are asserted. To use the watchdog function, connect WDI to a bus line or  $\mu\text{P}$  I/O line. If WDI remains high or low for longer than the watchdog timeout period (1.6s nominal),  $\overline{\text{WDO}}$ ,  $\overline{\text{RESET}}$ , and RESET are asserted, indicating a software fault or idle conditions. Refer to **RESET and RESET Outputs** and **Watchdog Output** sections.

### Watchdog Input

A change of logic state (minimum 100ns duration) at WDI during the watchdog period will reset the watchdog timer. The watchdog default timeout is 1.6sec.

To disable the watchdog function, leave WDI floating. An internal resistor network (100k $\Omega$  equivalent impedance at WDI) biases WDI to approximately 1.6V. Internal comparators detect this level and disable the watchdog timer. When  $V_{\text{CC}}$  is below the reset threshold, the watchdog function is disabled and WDI is disconnected from its internal resistor network, thus becoming high impedance.

### Watchdog Output

$\overline{\text{WDO}}$  remains high if there is activity (transition or pulse) at WDI during the watchdog-timeout period. The watchdog function is disabled and  $\overline{\text{WDO}}$  is a logic high when  $V_{\text{CC}}$  is less than the reset threshold or when WDI is an open circuit. In watchdog mode, if no transition occurs at WDI during the watchdog-timeout period,

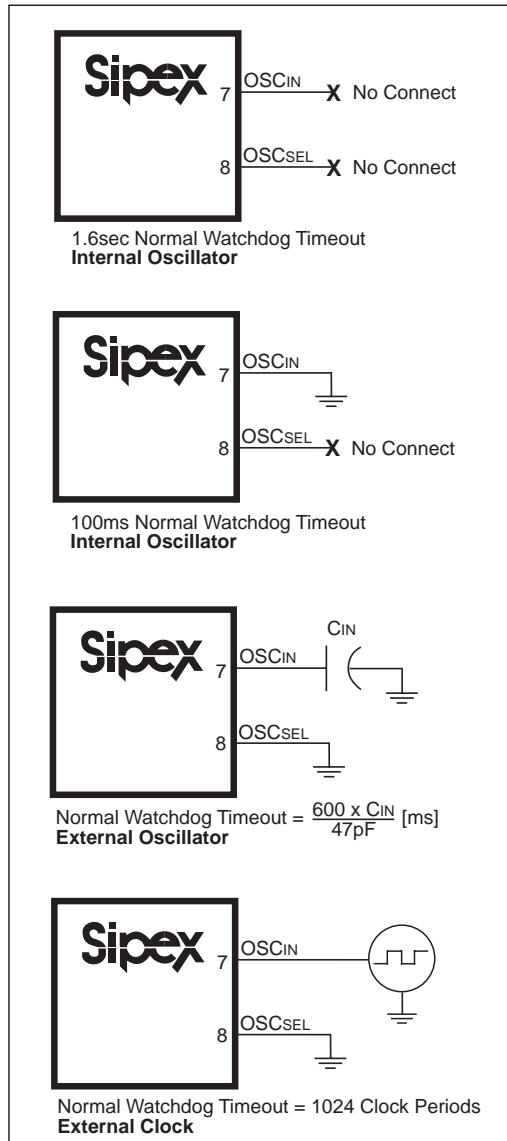

Figure 21. Selecting Timeout Periods

| OSC <sub>SEL</sub> | OSC <sub>IN</sub>    | Watchdog Timeout Period |                         | Reset Timeout Period |
|--------------------|----------------------|-------------------------|-------------------------|----------------------|
|                    |                      | Normal                  | Immediately After Reset |                      |
| LOW                | External Clock Input | 1024 clocks             | 4096 clocks             | 2048 clocks          |
| LOW                | External Capacitor   | (600/47pF x C) ms       | (2.4/4.7pf x C) sec     | (1200/47pF x C) ms   |
| Floating           | LOW                  | 100 ms                  | 1.6 s                   | 200 ms               |
| Floating           | Floating             | 1.6 s                   | 1.6 s                   | 200 ms               |

Table 1. Reset Pulse Width and Watchdog Timeout Selections

$\overline{\text{RESET}}$  and RESET are asserted for the reset timeout period (200ms nominal).  $\overline{\text{WDO}}$  goes to logic low and remains low until the next transition at WDI. Refer to *Figure 20*. If WDI is held high or low indefinitely,  $\overline{\text{RESET}}$  and RESET will generate 200ms pulses every 1.6s.  $\overline{\text{WDO}}$  has a 2 x TTL output characteristic.

### Selecting an Alternative Watchdog Timeout Period

The OSC<sub>SEL</sub> and OSC<sub>IN</sub> inputs control the watchdog reset timeout periods. Floating OSC<sub>SEL</sub> and OSC<sub>IN</sub> or tying them both to V<sub>OUT</sub> selects the nominal 1.6s watchdog timeout period and 200ms reset timeout period. Connecting OSC<sub>IN</sub> to ground and floating or connecting OSC<sub>SEL</sub> to V<sub>OUT</sub> selects a 100ms normal watchdog timeout period and a 1.6s timeout period immediately after reset. The reset timeout period remains 200ms. Refer to *Figure 20*. Select alternative timeout periods by connecting OSC<sub>SEL</sub> to ground and connecting a capacitor between OSC<sub>IN</sub> and ground, or by externally driving OSC<sub>IN</sub>. A synopsis of this control can be found in *Figure 21* and *Table 1*.

### Chip-Enable Signal Gating

The **SP691A/693A/800L/800M** devices provide internal gating of chip-enable (CE) signals, to prevent erroneous data from corrupting the CMOS RAM in the event of a power failure. During normal operation, the CE gate is enabled and passes all CE transitions. When reset is asserted, this path becomes disabled, preventing erroneous data from corrupting the CMOS RAM. The **SP691A/693A/800L/800M** devices use a series transmission gate from  $\overline{\text{CE}}_{\text{IN}}$  to  $\overline{\text{CE}}_{\text{OUT}}$ . Refer to *Figure 16*.

The 10ns maximum CE propagation from  $\overline{\text{CE}}_{\text{IN}}$  to  $\overline{\text{CE}}_{\text{OUT}}$  enables the **SP691A/693A/800L/800M** devices to be used with most  $\mu\text{Ps}$ .

### Chip-Enable Input

$\overline{\text{CE}}_{\text{IN}}$  is in high impedance (disabled mode) while  $\overline{\text{RESET}}$  and/or RESET are asserted.

During a power-down sequence where V<sub>CC</sub> falls below the reset threshold,  $\overline{\text{CE}}_{\text{IN}}$  assumes a high impedance state when the voltage at  $\overline{\text{CE}}_{\text{IN}}$  goes high or 12 $\mu\text{s}$  after RESET is asserted, whichever occurs first. Refer to *Figure 19*. During a power-up sequence,  $\overline{\text{CE}}_{\text{IN}}$  remains high impedance until RESET is deasserted.

In the high-impedance mode, the leakage currents into  $\overline{\text{CE}}_{\text{IN}}$  are <1 $\mu\text{A}$  over temperature. In the low-impedance mode, the impedance of  $\overline{\text{CE}}_{\text{IN}}$  appears as a 65 $\Omega$  resistor in series with the load at  $\overline{\text{CE}}_{\text{OUT}}$ .

The propagation delay through the CE transmission gate depends on both the source impedance of the drive to  $\overline{\text{CE}}_{\text{IN}}$  and the capacitive loading on  $\overline{\text{CE}}_{\text{OUT}}$  (see the Chip-Enable Propagation Delay vs.  $\overline{\text{CE}}_{\text{OUT}}$  Load Capacitance graph in the **Typical Performance Characteristics** section). The CE propagation delay is defined from the 50% point on  $\overline{\text{CE}}_{\text{IN}}$  to the 50% point on  $\overline{\text{CE}}_{\text{OUT}}$  using a 50 $\Omega$  driver and 50pF of load capacitance as in *Figure 22*. For minimum propagation delay, minimize the capacitive load at  $\overline{\text{CE}}_{\text{OUT}}$  and use a low output-impedance driver.

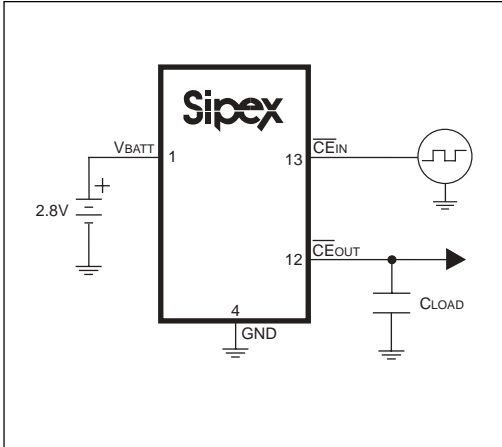

Figure 22. Chip Enable Propagation Delay Test Circuit

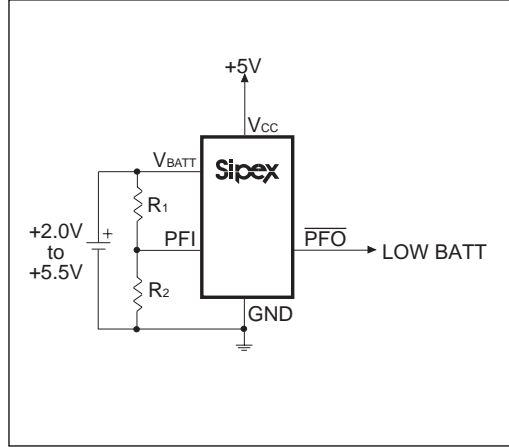

Figure 23. Low-Battery Indicator Circuit

## Chip-Enable Output

In the enabled mode, the impedance of  $\overline{CE}_{OUT}$  is equivalent to  $65\Omega$  in series with the source driving  $\overline{CE}_{IN}$ . In the disabled mode, the  $65\Omega$  transmission gate is off and  $\overline{CE}_{OUT}$  is actively pulled to  $V_{OUT}$ . This source turns off when the transmission gate is enabled.

## LOWLINE Output

LOWLINE is the buffered output pin of the reset threshold comparator. Refer to *Figure 16*. LOWLINE typically sinks 3.2mA at 0.1V. For normal operation where  $V_{CC}$  is above the reset threshold, LOWLINE is pulled to  $V_{OUT}$ .

## Power-Fail Comparator

The power-fail comparator is an uncommitted comparator that has no effect on the other functions of the **SP691A/693A/800L/800M** devices. Common uses include low battery detection, as found in *Figure 23*, and early power-fail detection when the unregulated power is easily accessible as shown in *Figure 17*.

## Power-Fail Input

The Power-Fail Input (PFI) has a guaranteed input leakage of  $\pm 25\text{nA}$  max over temperature. The typical comparator delay is  $25\mu\text{s}$  from  $V_{IL}$  to  $V_{OL}$  (power failing), and  $60\mu\text{s}$  from  $V_{IH}$  to  $V_{OH}$  (power being restored). Connect this input to ground if PFI is not used.

## Power-Fail Output

The Power-Fail Output ( $\overline{PFO}$ ) goes low when PFI goes below 1.25V. It sinks 3.2mA with a saturation voltage of 0.1V. With PFI above 1.25V, PFO is actively pulled to  $V_{OUT}$ . PFO can be used to generate an NMI for the  $\mu\text{P}$ , as shown in *Figure 17*.

## Battery-Backup Mode

The **SP691A/693A/800L/800M** requires two conditions to switch to battery-backup mode: 1)  $V_{CC}$  must be below the reset threshold; 2)  $V_{CC}$  must be below  $V_{BATT}$ . *Table 2* lists the status of the inputs and outputs in battery-backup mode.

## Battery-On Output

The Battery On Output (BATT ON) indicates the status of the internal  $V_{CC}$ /battery-switchover comparator, which controls the internal  $V_{CC}$  and  $V_{BATT}$  switches. For  $V_{CC}$  greater than  $V_{BATT}$  (ignoring the small hysteresis effect), BATT ON is a logic low. For  $V_{CC}$  less than  $V_{BATT}$ , BATT ON is a logic high. Use BATT ON to indicate battery-switchover status or to supply base drive to an external pass transistor for higher-current applications. Refer to *Figure 17*.

| NAME                         | STATUS   | PIN NUMBER |
|------------------------------|--|------------|
| $V_{BATT}$                   | Supply current is $1\mu\text{A}$ maximum when $V_{CC} < (V_{BATT} - 1.2\text{V})$ .                              | 1          |
| $V_{OUT}$                    | $V_{OUT}$ connected to $V_{BATT}$ through an internal PMOS switch.   | 2          |
| $V_{CC}$                     | Battery switchover comparator monitors $V_{CC}$ for active switchover. $V_{CC}$ is disconnected from $V_{OUT}$ . | 3          |
| GND                          | 0V reference for all signals.  | 4          |
| BATT ON                      | Logic HIGH. The open-circuit output voltage is equal to $V_{OUT}$ .  | 5          |
| $\overline{\text{LOWLINE}}$  | Logic LOW.   | 6          |
| $\text{OSC}_{IN}$            | $\text{OSC}_{IN}$ is ignored and is at high-Z.   | 7          |
| $\text{OSC}_{SEL}$           | $\text{OSC}_{SEL}$ is ignored and is at high-Z.  | 8          |
| PFI                          | The power-fail comparator is disabled.   | 9          |
| $\overline{\text{PFO}}$      | The power-fail comparator is disabled. PFO is forced to logic LOW.   | 10         |
| WDI                          | WDI is ignored and is at high-Z.   | 11         |
| $\overline{\text{CE}}_{OUT}$ | Logic HIGH. The open-circuit output voltage is equal to $V_{OUT}$ .  | 12         |
| $\overline{\text{CE}}_{IN}$  | High-Z.  | 13         |
| $\overline{\text{WDO}}$      | Logic HIGH. The open-circuit output voltage is equal to $V_{OUT}$ .  | 14         |
| $\overline{\text{RESET}}$    | Logic LOW.   | 15         |
| RESET                        | High-Z.  | 16         |

**Table 2. Input and Output Status in Battery-Backup Mode; to enter the Battery-Backup Mode,  $V_{CC}$  must be less than the reset threshold and less than  $V_{BATT}$**

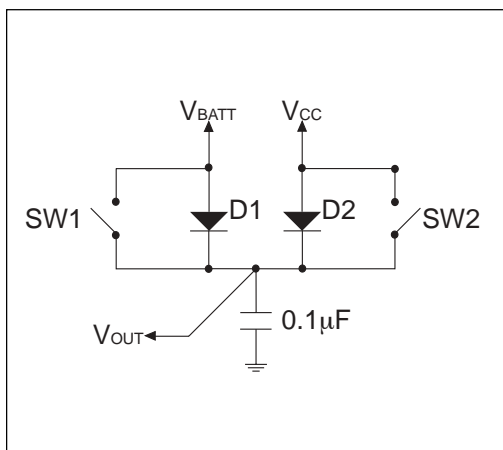

**Figure 24.  $V_{CC}$  and  $V_{BATT}$  to  $V_{OUT}$  Switch**

## Input Supply Voltage

The Input Supply Voltage ( $V_{CC}$ ) should be a regulated +5V source.  $V_{CC}$  connects to  $V_{OUT}$  via a parallel diode and a large PMOS switch. The switch carries the entire current load for currents less than 250mA. The parallel diode carries any current in excess of 250mA. Both the switch and the diode have impedances less than  $1\Omega$  each. Refer to *Figure 24*. The maximum continuous current is 250mA, but power-on transients may reach a maximum of 1A.

## Backup-Battery Input

The Backup-Battery Input ( $V_{BATT}$ ) is similar to  $V_{CC}$ , except the PMOS switch and parallel diode are much smaller. Refer to *Figure 24*. Accordingly, the on-resistances of the diode and the switch are each approximately  $10\Omega$ .

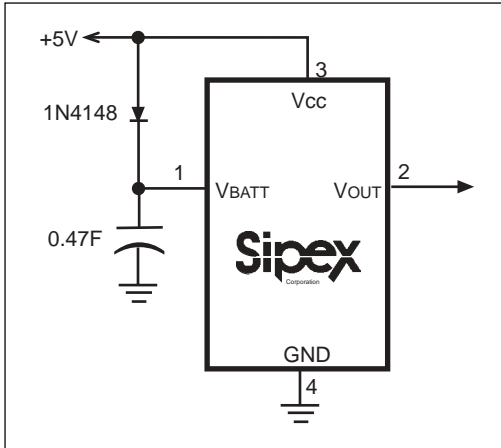

**Figure 25. High Capacity Capacitor on  $V_{BATT}$**

Continuous current should be limited to 25mA and peak currents (only during power-up) limited to 250mA. The reverse leakage of this input is less than 1 $\mu$ A over temperature and supply voltage.

### Output Supply Voltage

The Output Supply Voltage ( $V_{OUT}$ ) supplies all the current to the external system and internal circuitry. All open-circuit outputs will assume the  $V_{OUT}$  voltage in their high states rather than the  $V_{CC}$  voltage. At the maximum source current of 250mA,  $V_{OUT}$  will typically be 150mV below  $V_{CC}$ .  $V_{OUT}$  should be decoupled with 0.1 $\mu$ F capacitor.

### TYPICAL APPLICATIONS

The **SP691A/693A/800L/800M** devices are not short-circuit protected. Shorting  $V_{OUT}$  to ground, other than power-up transients such as charging a decoupling capacitor, may destroy the device. All open-circuit outputs swing between  $V_{OUT}$  and  $GND$  rather than  $V_{CC}$  and  $GND$ . If long leads connect to the chip inputs, ensure that these lines are free from ringing and other conditions that would forward bias the chip's protection diodes.

There are three distinct modes of operation:

- 1) Normal operating mode with all circuitry powered from  $V_{CC}$ . Typical supply current from  $V_{CC}$  is 35 $\mu$ A, while only leakage currents flow from the battery.

- 2) Battery-backup mode where  $V_{CC}$  is typically within 0.7V below  $V_{BATT}$ . All circuitry is powered from  $V_{BATT}$  and the supply current from the battery is typically less than 5 $\mu$ A.

- 3) Battery-backup mode where  $V_{CC}$  is less than  $V_{BATT}$  by at least 0.7V.  $V_{BATT}$  supply current is less than 1 $\mu$ A max.

### Using High Capacity Capacitor with the SP691A/693A/800L/800M Series

$V_{BATT}$  has the same operating voltage range as  $V_{CC}$ , and the battery-switchover threshold voltages are typically +30mV centered at  $V_{BATT}$ , allowing use of a capacitor and a simple charging circuit as a backup source. Refer to *Figure 25*.

If  $V_{CC}$  is above the reset threshold and  $V_{BATT}$  is 0.5V above  $V_{CC}$ , current flows to  $V_{OUT}$  and  $V_{CC}$  from  $V_{BATT}$  until the voltage at  $V_{BATT}$  is less than 0.5V above  $V_{CC}$ .

Leakage current through the capacitor charging diode and **SP691A/693A/800L/800M** internal power diode eventually discharges the capacitor to  $V_{CC}$ . Also, if  $V_{CC}$  and  $V_{BATT}$  start from 0.5V above the reset threshold and power is lost at  $V_{CC}$ , the capacitor on  $V_{BATT}$  discharges through  $V_{CC}$  until  $V_{BATT}$  reaches the reset threshold; the **SP691A/693A/800L/800M** devices then switch to battery-backup mode.

### Using Separate Power Supplies for $V_{BATT}$ and $V_{CC}$

If using separate power supplies for  $V_{CC}$  and  $V_{BATT}$ ,  $V_{BATT}$  must be less than 0.3V above  $V_{CC}$  when  $V_{CC}$  is above the reset threshold. As described in the previous section, if  $V_{BATT}$  exceeds this limit and power is lost at  $V_{CC}$ , current flows continuously from  $V_{BATT}$  to  $V_{CC}$  via the  $V_{BATT}$ -to- $V_{OUT}$  diode and the  $V_{OUT}$ -to- $V_{CC}$  switch until the circuit is broken. Refer to *Figure 24*.

### Alternative Chip-Enable Gating

Using memory devices with  $\overline{CE}$  and  $\overline{CE}_{IN}$  inputs allows the  $\overline{CE}$  loop of the **SP691A/693A/800L/800M** series to be bypassed. To do this, connect  $\overline{CE}_{IN}$  to ground, pull up  $\overline{CE}_{OUT}$  to  $V_{OUT}$ ,



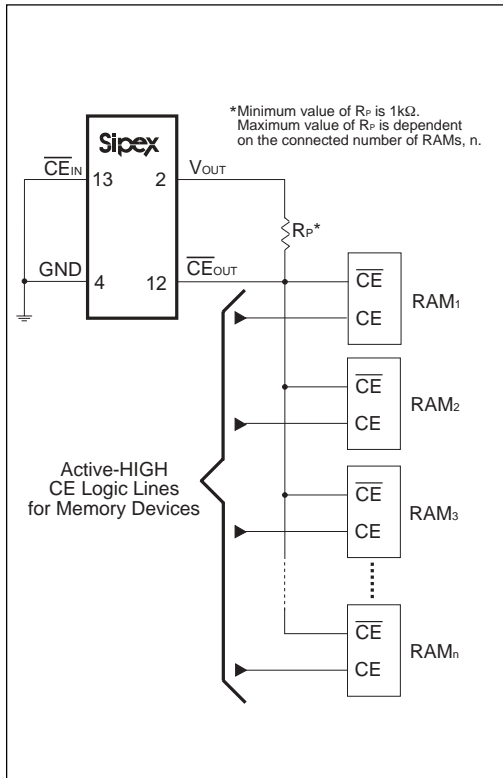

Figure 26. Alternate Chip Enable Gating

and connect  $\overline{CE}_{OUT}$  to the  $\overline{CE}$  input of each memory device as shown in Figure 26. The CE input of each part then connects directly to the chip-select logic, which does not have to be gated by the SP691A/693A/800L/800M devices.

### Adding Hysteresis to the Power-Fail Comparator

Hysteresis adds noise margin to the power-fail comparator and prevents repeated triggering of  $\overline{PFO}$  when  $V_{IN}$  is near the power-fail comparator trip point. Figure 27 shows how to add hysteresis to the power-fail comparator. Select the ratio of  $R_1$  and  $R_2$  such that PFI sees 1.25V when  $V_{IN}$  falls to the desired trip point ( $V_{TRIP}$ ). Resistor  $R_3$  adds hysteresis. It will typically be an order of magnitude greater than  $R_1$  or  $R_2$ . The current through  $R_1$  and  $R_2$  should be at least  $1\mu A$  to ensure that the 25nA (max) PFI input current does not shift the trip point.  $R_3$  should

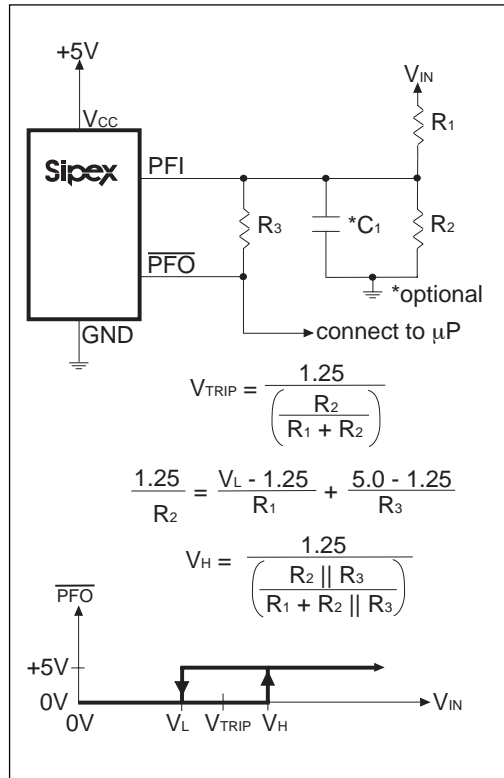

Figure 27. Adding Hysteresis to the Power-Fail Comparator

be larger than  $10k\Omega$  to prevent it from loading down the  $\overline{PFO}$  pin. Capacitor  $C_1$  adds additional noise rejection.

### Monitoring a Negative Voltage

The power-fail comparator can be used to monitor a negative supply voltage using the circuit shown in Figure 28. When the negative supply is valid,  $\overline{PFO}$  is low. When the negative supply voltage drops,  $\overline{PFO}$  goes high. This circuit's accuracy is affected by the PFI threshold tolerance, the  $V_{CC}$  voltage, and resistors  $R_1$  and  $R_2$ .

### Backup-Battery Replacement

The backup battery may be disconnected while  $V_{CC}$  is above the reset threshold. No precautions are necessary to avoid spurious reset pulses.

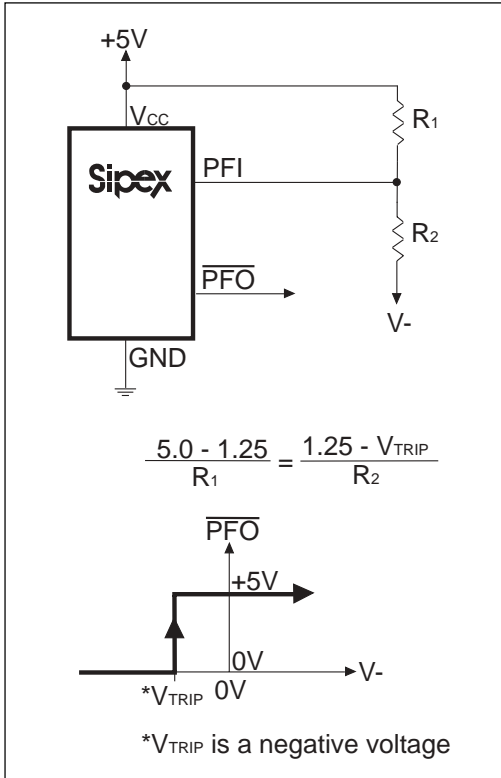

Figure 28. Monitoring a Negative Voltage

### Negative-Going $V_{CC}$ Transients

While asserting resets to the  $\mu P$  during power-up, power-down, and brownout conditions, these supervisors are relatively immune to short-duration negative-going  $V_{CC}$  transients. It is usually undesirable to reset the  $\mu P$  when  $V_{CC}$  experiences only small glitches.

Refer to Figure 29 for a graph of the maximum transient duration vs. the reset-comparator overdrive for which reset pulses are not generated. The graph was produced using negative-going pulses, starting at 5V and ending below the reset threshold by the magnitude indicated (reset comparator overdrive). The graph shows the maximum pulse width a negative-going  $V_{CC}$  transient may typically have without causing a reset pulse to be issued.

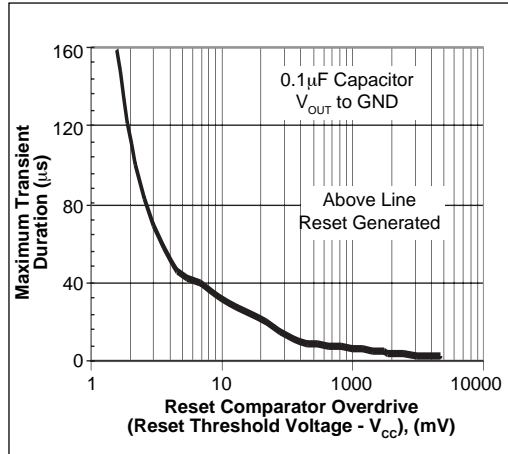

Figure 29. Maximum Transient Duration Without Causing a Reset Pulse vs. Reset Comparator Overdrive

As the amplitude of the transient increases (i.e., goes farther below the reset threshold), the maximum allowable pulse width decreases. Typically, a  $V_{CC}$  transient that goes 100mV below the reset threshold and lasts for 40 $\mu s$  or less will not cause a reset pulse to be issued. A 100nF bypass capacitor mounted close to the  $V_{CC}$  pin provides additional transient immunity.

### Connecting a Timing Capacitor to $OSC_{IN}$

When  $OSC_{SEL}$  is connected to ground,  $OSC_{IN}$  disconnects from its internal 10 $\mu A$  pull-up and is internally connected to a  $\pm 100nA$  current source. When a capacitor is connected from  $OSC_{IN}$  to ground (to select an alternative watchdog timeout period), the current source charges and discharges the timing capacitor to create the oscillator that controls the reset and watchdog timeout period. To prevent timing errors, minimize external current leakage sources at this pin, and locate the capacitor as close to  $OSC_{IN}$  as possible. The sum of any PC board leakage plus the  $OSC$  capacitor leakage must be small compared to  $\pm 100nA$ .

## Watchdog Software Considerations

A way to help the watchdog timer keep a closer watch on software execution involves setting and resetting the watchdog input at different points in the program, rather than "pulsing" the watchdog input high-low-high or low-high-low. This technique avoids a "stuck" loop where the watchdog timer continues to be reset within the loop, keeping the watchdog from timing out.

Figure 30 shows an example flow diagram where the I/O driving the watchdog input is set high at the beginning of the program, set low at the beginning of every subroutining or loop, then set high again when the program returns to the beginning. If the program should "hang" in any subroutine, the I/O is continually set low and the watchdog timer is allowed to time out, causing a reset or interrupt to be issued.

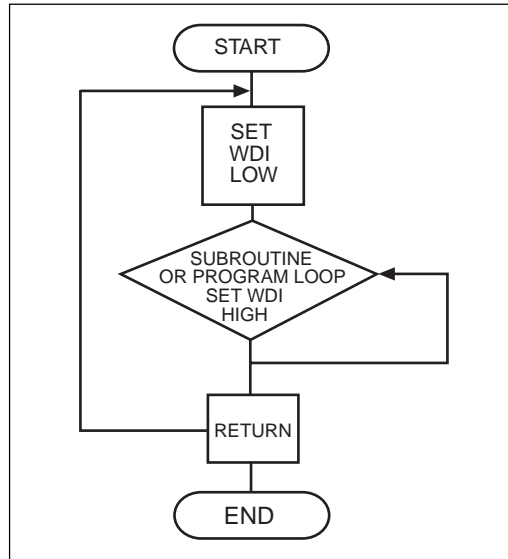
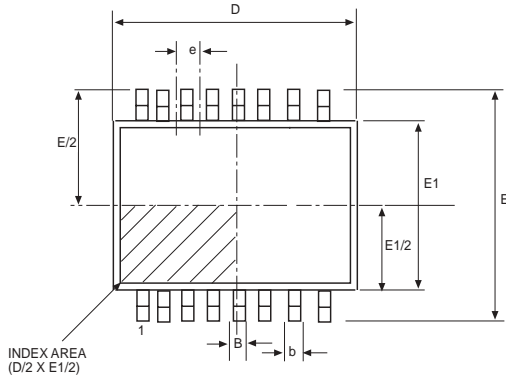

Figure 30. Watchdog Flow Diagram

## Maximum $V_{CC}$ Fall Time

The  $V_{CC}$  fall time is limited by the propagation delay of the battery switchover comparator and should not exceed  $0.03V/\mu s$ . A standard rule of thumb for filter capacitance on most regulators is on the order of  $100\mu F$  per amp of current. When the power supply is shut off or the main battery is disconnected, the associated initial  $V_{CC}$  fall rate is just the inverse of  $1A/100\mu F = 0.01V/\mu s$ . The  $V_{CC}$  fall rate decreases with time as  $V_{CC}$  falls exponentially, which more than satisfies the maximum fall-time requirement.

**PACKAGE: 16 PIN NSOIC**



**TOP VIEW**

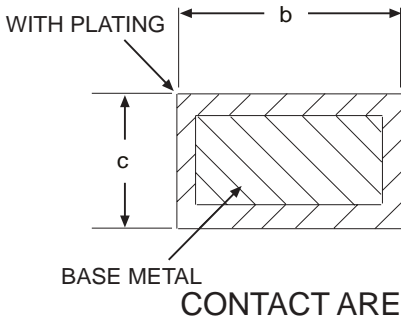
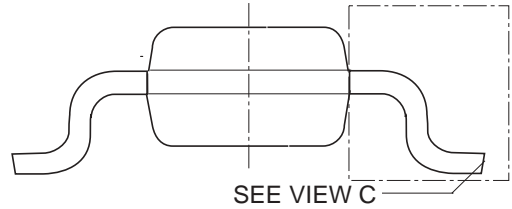

**CONTACT AREA**

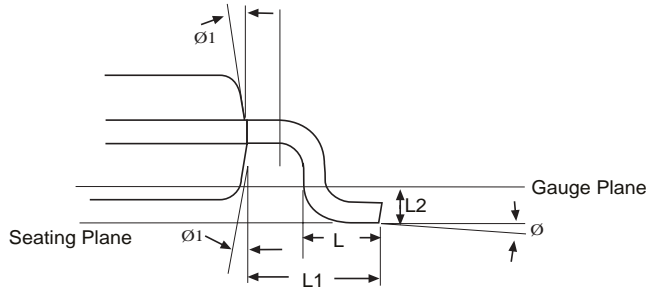

**VIEW C**

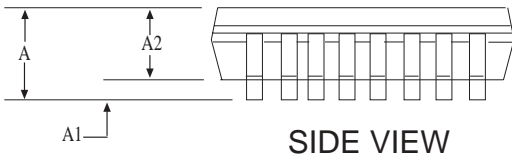

**SIDE VIEW**

| DIMENSIONS<br>Minimum/Maximum<br>(mm) | 16 Pin NSOIC<br>(JEDEC MS-012,<br>AC - VARIATION) |     |      |
|---------------------------------------|---|-----|------|
| <b>COMMON HEIGHT DIMENSION</b>        |   |     |      |
| SYMBOL                                | MIN   | NOM | MAX  |
| A                                     | 1.35  | -   | 1.75 |
| A1                                    | 0.10  | -   | 0.25 |
| A2                                    | 1.25  | -   | 1.65 |
| b                                     | 0.31  | -   | 0.51 |
| c                                     | 0.17  | -   | 0.25 |
| D                                     | 9.90 BSC  |     |      |
| E                                     | 6.00 BSC  |     |      |
| E1                                    | 3.90 BSC  |     |      |
| e                                     | 1.27 BSC  |     |      |
| L                                     | 0.40  | -   | 1.27 |
| L1                                    | 1.04 REF  |     |      |
| L2                                    | 0.25 BSC  |     |      |
| Ø                                     | 0°  | -   | 8°   |
| Ø1                                    | 5°  | -   | 15°  |

**16 PIN NSOIC**

**PACKAGE: 16 PIN WSOIC**

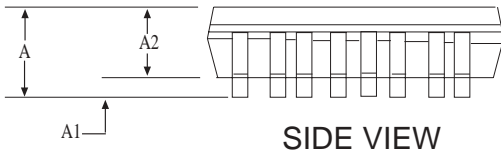
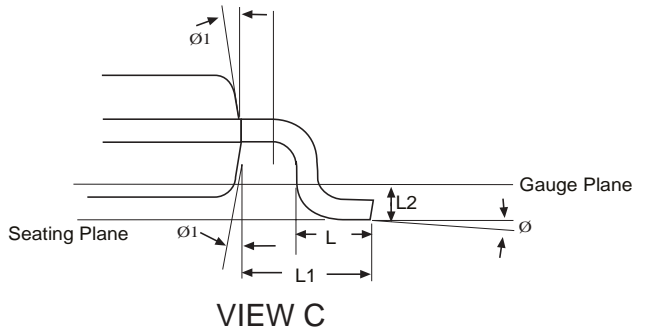
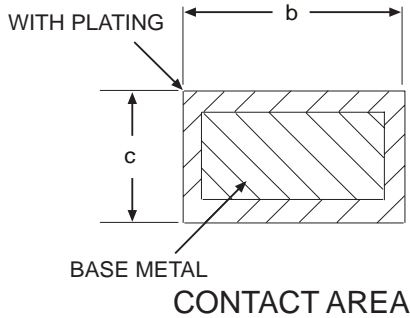
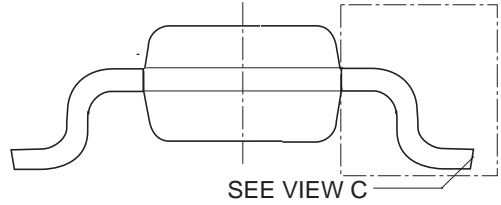
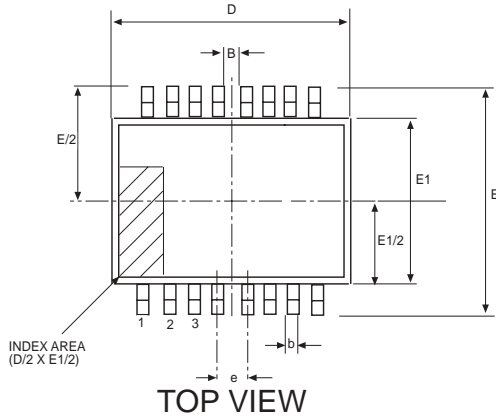

| DIMENSIONS<br>Minimum/Maximum<br>(mm) |           | 16 Pin SOIC (WIDE)<br>(JEDEC MS-013,<br>AA - VARIATION) |      |
|---------------------------------------|-----------|---|------|
| <b>COMMON HEIGHT DIMENSION</b>        |           |   |      |
| SYMBOL                                | MIN       | NOM   | MAX  |
| A                                     | 2.35      | -   | 2.65 |
| A1                                    | 0.10      | -   | 0.30 |
| A2                                    | 2.05      | -   | 2.55 |
| b                                     | 0.31      | -   | 0.51 |
| c                                     | 0.20      | -   | 0.33 |
| D                                     | 10.30 BSC |   |      |
| E                                     | 10.30 BSC |   |      |
| E1                                    | 7.50 BSC  |   |      |
| e                                     | 1.27 BSC  |   |      |
| L                                     | 0.40      | -   | 1.27 |
| L1                                    | 1.40 REF  |   |      |
| L2                                    | 0.25 BSC  |   |      |
| $\phi$                                | 0°        | -   | 8°   |
| $\phi 1$                              | 5°        | -   | 15°  |

**16 PIN SOIC WIDE**

**PACKAGE: 16 PIN PDIP**

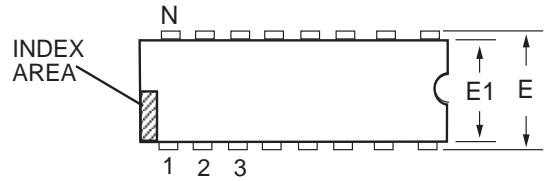
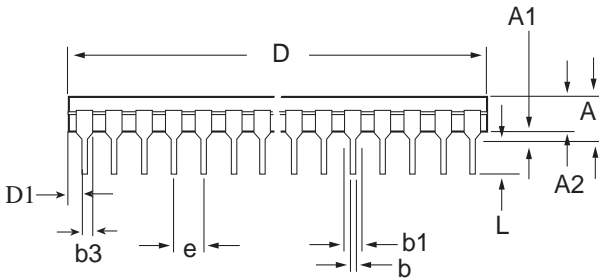

| Dimensions in (mm) | 16 PIN PDIP<br>JEDEC MS-001<br>(BB) Variation |      |      |
|--------------------|---|------|------|
|                    | MIN   | NOM  | MAX  |
| A                  | -   | -    | .210 |
| A1                 | .015  | -    | -    |
| A2                 | .115  | .130 | .195 |
| b                  | .014  | .018 | .022 |
| b2                 | .045  | .060 | .070 |
| b3                 | .030  | .039 | .045 |
| c                  | .008  | .010 | .014 |
| D                  | .735  | .755 | .775 |
| D1                 | .005  | -    | -    |
| E                  | .300  | .310 | .325 |
| E1                 | .240  | .250 | .280 |
| e                  | .100 BSC                                      |      |      |
| eA                 | .300 BSC                                      |      |      |
| eB                 | -   | -    | .430 |
| L                  | .115  | .130 | .150 |

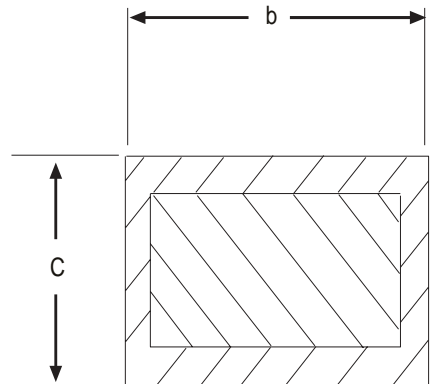
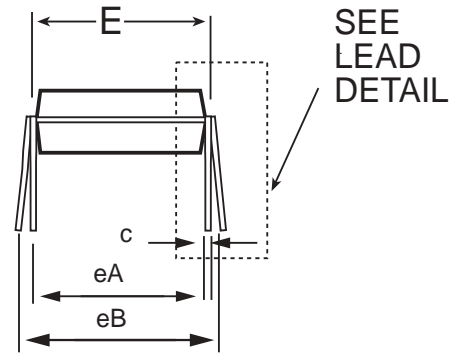

**16 pin PDIP**

---

## ORDERING INFORMATION

| Part Number       | Temperature Range    | Package Type |
|-------------------|----------------------|--------------|
| SP691ACP .....    | 0°C to +70°C .....   | 16-Pin PDIP  |
| SP691ACN .....    | 0°C to +70°C .....   | 16-Pin NSOIC |
| SP691ACN/TR ..... | 0°C to +70°C .....   | 16-Pin NSOIC |
| SP691ACT .....    | 0°C to +70°C .....   | 16-Pin WSOIC |
| SP691ACT/TR ..... | 0°C to +70°C .....   | 16-Pin WSOIC |
| SP691AEP .....    | -40°C to +85°C ..... | 16-Pin PDIP  |
| SP691AEN .....    | -40°C to +85°C ..... | 16-Pin NSOIC |
| SP691AEN/TR ..... | -40°C to +85°C ..... | 16-Pin NSOIC |
| SP691AET .....    | -40°C to +85°C ..... | 16-Pin WSOIC |
| SP691AET/TR ..... | -40°C to +85°C ..... | 16-Pin WSOIC |

|                   |                      |              |
|-------------------|----------------------|--------------|
| SP693ACP .....    | 0°C to +70°C .....   | 16-Pin PDIP  |
| SP693ACN .....    | 0°C to +70°C .....   | 16-Pin NSOIC |
| SP693ACN/TR ..... | 0°C to +70°C .....   | 16-Pin NSOIC |
| SP693ACT .....    | 0°C to +70°C .....   | 16-Pin WSOIC |
| SP693ACT/TR ..... | 0°C to +70°C .....   | 16-Pin WSOIC |
| SP693AEP .....    | -40°C to +85°C ..... | 16-Pin PDIP  |
| SP693AEN .....    | -40°C to +85°C ..... | 16-Pin NSOIC |
| SP693AEN/TR ..... | -40°C to +85°C ..... | 16-Pin NSOIC |
| SP693AET .....    | -40°C to +85°C ..... | 16-Pin WSOIC |
| SP693AET/TR ..... | -40°C to +85°C ..... | 16-Pin WSOIC |

Available in lead free packaging. To order add "-L" suffix to part number.

Example: SP691AEN/TR = standard; SP691AEN-L/TR = lead free

/TR = Tape and Reel

Pack quantity is 2500 for NSOIC and WSOIC.



ANALOG EXCELLENCE

**Sipex Corporation**

**Headquarters and  
Sales Office**  
233 South Hillview Drive  
Milpitas, CA 95035  
TEL: (408) 934-7500  
FAX: (408) 935-7600

---

## ORDERING INFORMATION

| Part Number       | Temperature Range    | Package Type |
|-------------------|----------------------|--------------|
| SP800LCP .....    | 0°C to +70°C .....   | 16-Pin PDIP  |
| SP800LCN .....    | 0°C to +70°C .....   | 16-Pin NSOIC |
| SP800LCN/TR ..... | 0°C to +70°C .....   | 16-Pin NSOIC |
| SP800LCT .....    | 0°C to +70°C .....   | 16-Pin WSOIC |
| SP800LCT/TR ..... | 0°C to +70°C .....   | 16-Pin WSOIC |
| SP800LEP .....    | -40°C to +85°C ..... | 16-Pin PDIP  |
| SP800LEN .....    | -40°C to +85°C ..... | 16-Pin NSOIC |
| SP800LEN/TR ..... | -40°C to +85°C ..... | 16-Pin NSOIC |
| SP800LET .....    | -40°C to +85°C ..... | 16-Pin WSOIC |
| SP800LET/TR ..... | -40°C to +85°C ..... | 16-Pin WSOIC |
| <br>              |                      |              |
| SP800MCP .....    | 0°C to +70°C .....   | 16-Pin PDIP  |
| SP800MCN .....    | 0°C to +70°C .....   | 16-Pin NSOIC |
| SP800MCN/TR ..... | 0°C to +70°C .....   | 16-Pin NSOIC |
| SP800MCT .....    | 0°C to +70°C .....   | 16-Pin WSOIC |
| SP800MCT/TR ..... | 0°C to +70°C .....   | 16-Pin WSOIC |
| SP800MEP .....    | -40°C to +85°C ..... | 16-Pin PDIP  |
| SP800MEN .....    | -40°C to +85°C ..... | 16-Pin NSOIC |
| SP800MEN/TR ..... | -40°C to +85°C ..... | 16-Pin NSOIC |
| SP800MET .....    | -40°C to +85°C ..... | 16-Pin WSOIC |
| SP800MET/TR ..... | -40°C to +85°C ..... | 16-Pin WSOIC |

Available in lead free packaging. To order add "-L" suffix to part number.

Example: SP800MEN/TR = standard; SP800MEN-L/TR = lead free

/TR = Tape and Reel

Pack quantity is 2500 for NSOIC and WSOIC.



ANALOG EXCELLENCE

Sipex Corporation

**Headquarters and  
Sales Office**  
233 South Hillview Drive  
Milpitas, CA 95035  
TEL: (408) 934-7500  
FAX: (408) 935-7600