

Linear IC Converter

CMOS

A/D Converter

(With 4-channel Input at 12-bit Resolution)

MB88101A

DESCRIPTION

The MB88101A is an analog-to-digital converter that converts its analog input to a 12-bit digital value and outputs it as serial data.

The MB88101A employs a successive approximation method for A/D conversion.

The MB88101A has four input channels selectable for analog input under control of the dedicated external pins.

The MB88101A can be switched to a mode for continuous A/D conversion, in which it outputs serial data from the MSB or LSB selectable depending on the mode setting.

FEATURES

- 4-channel analog input
- One analog input channel selectable for conversion by external control
- CR-type successive approximation system with a sample-and-hold circuit
- 12-bit resolution
- Serial output of 12-bit digital data
- Capable of continuous conversion (continuous conversion mode)
- MSB or LSB selectable for serial output
- CMOS process
- Package options of 16-pin DIP, SSOP, and SOP available

PACKAGES

16-pin Plastic DIP

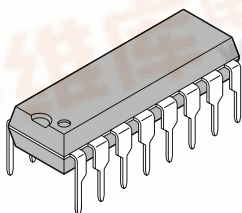

(DIP-16P-M04)

16-pin Plastic SSOP

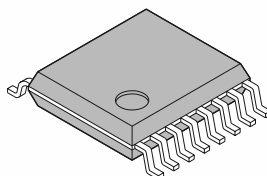

(FPT-16P-M05)

16-pin Plastic SOP

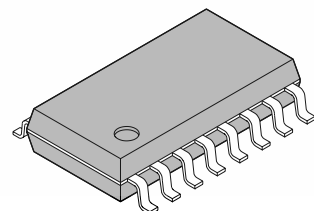

(FPT-16P-M06)

MB88101A

■ PIN ASSIGNMENT

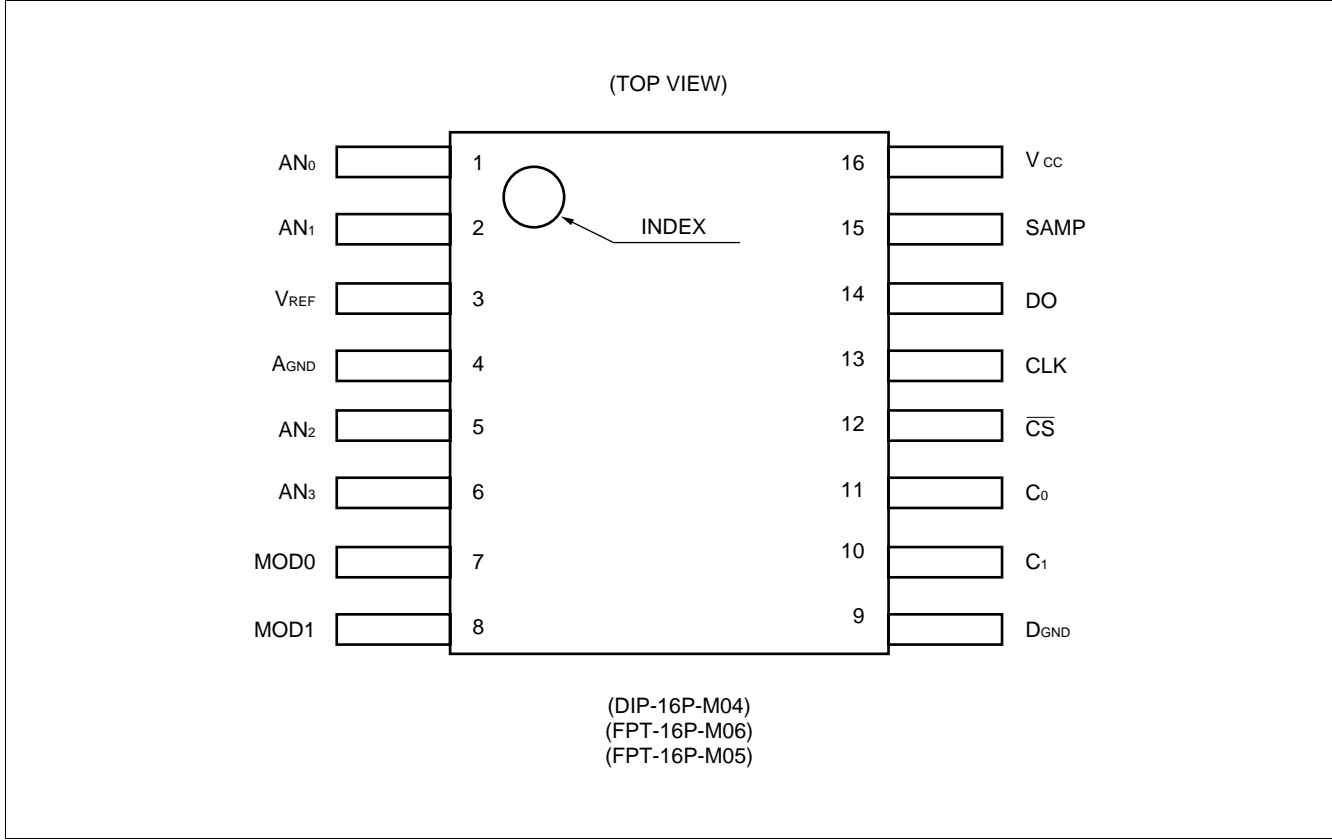

■ PIN DESCRIPTION

| Pin no. | Symbol | I/O | Descriptions |
|------------------|--|-----|---|
| 1 2 5 6 | AN ₀ AN ₁ AN ₂ AN ₃ | I | Analog input pins. One of these channels can be selected depending on the C ₀ and C ₁ settings. |
| 14 | DO | O | This pin outputs the result of A/D conversion. The result is 12-bit serial data output in synchronization with the rise of CLK. |
| 13 | CLK | I | Clock input pin for A/D conversion |
| 12 | \overline{CS} | I | Chip select signal input pin. Setting the signal level to "L" after turning the power on starts A/D conversion; setting it to "H" stops A/D conversion. When this pin is "H", the DO and SAMP pins are "Hi-z". |
| 11 10 | C ₀ C ₁ | I | Input pins for selecting the analog input channels from among pins AN ₀ to AN ₃ . See Table 1 for the correspondence between the pin settings and the channels selected. To switch the channel in mode 2 or 3, set these pins before the SAMP pin goes "H". |
| 7 8 | MOD0 MOD1 | I | Conversion mode setting pins. For the correspondence between the pin settings and the modes selected, see Table 2 and "■ FUNCTIONAL DESCRIPTION." |
| 15 | SAMP | O | This pin becomes active in prior to data output. Serial data is output from the DO pin three clock cycles after the signal level at this pin goes "L" after "H" for one clock cycle. |
| 3 | V _{REF} | — | Reference voltage input pin |
| 4 | A _{GND} | — | Analog circuit ground pin |
| 9 | D _{GND} | — | Digital circuit ground pin |
| 16 | V _{CC} | — | Power supply pin |

• Channel selection

Table 1 Pin Settings and Channel Selection

| C ₁ | C ₀ | Channel |
|----------------|----------------|-----------------|
| L | L | AN ₀ |
| L | H | AN ₁ |
| H | L | AN ₂ |
| H | H | AN ₃ |

• Mode selection

Table 2 Pin Settings and Mode Selection

| MOD 0 | MOD1 | Mode |
|-------|------|------------|
| L | L | Mode 1 |
| L | H | Mode 2 |
| H | L | (Disabled) |
| H | H | Mode 3 |

MB88101A

■ BLOCK DIAGRAM

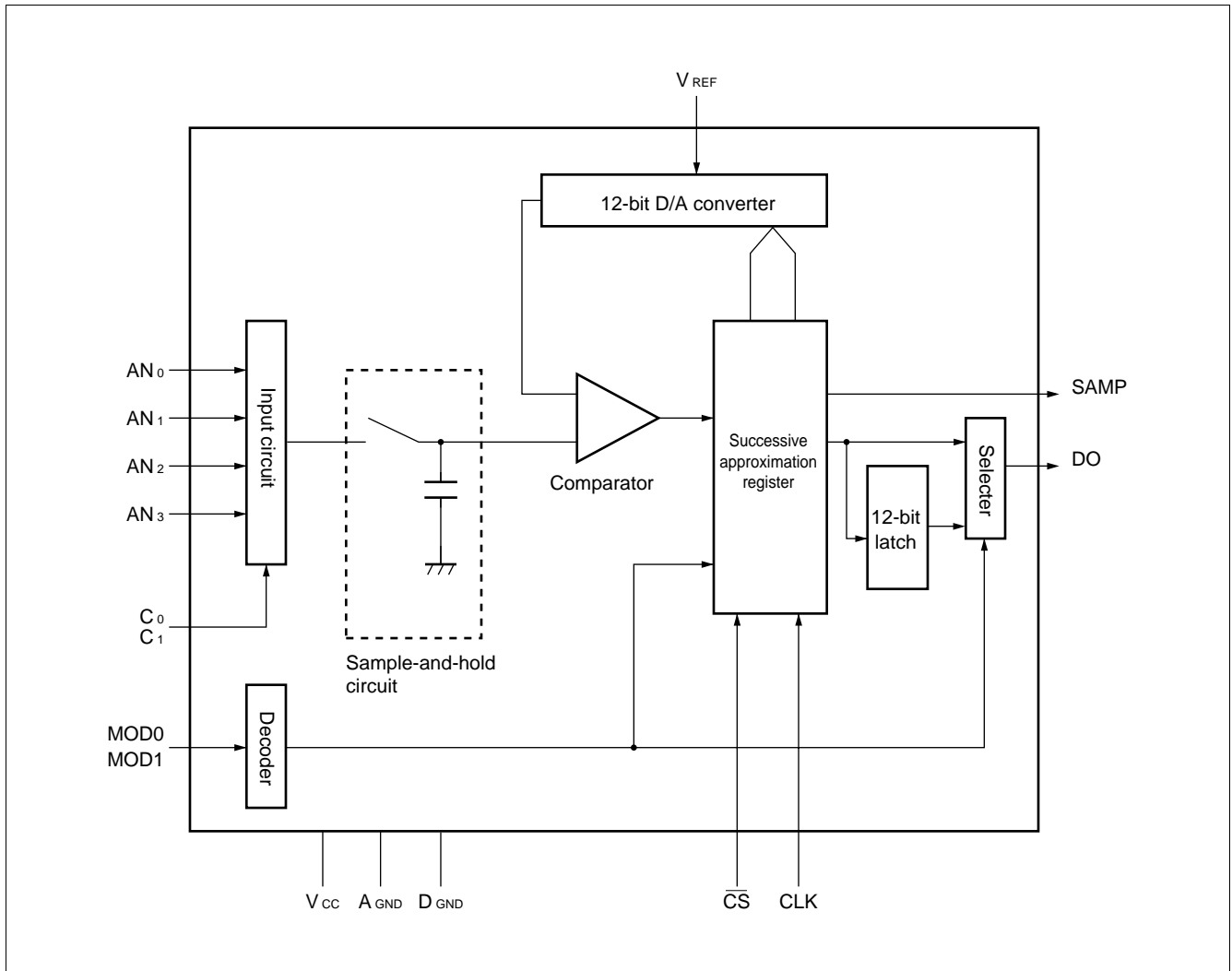

FUNCTIONAL DESCRIPTION

1. Mode 1

This mode sets the DO pin to “L” and stops conversion upon completion of conversion of 12 bits. To restart conversion, set \overline{CS} to “H” once then to “L”. In this mode, converted data is output from the MSB.

• Timing diagram

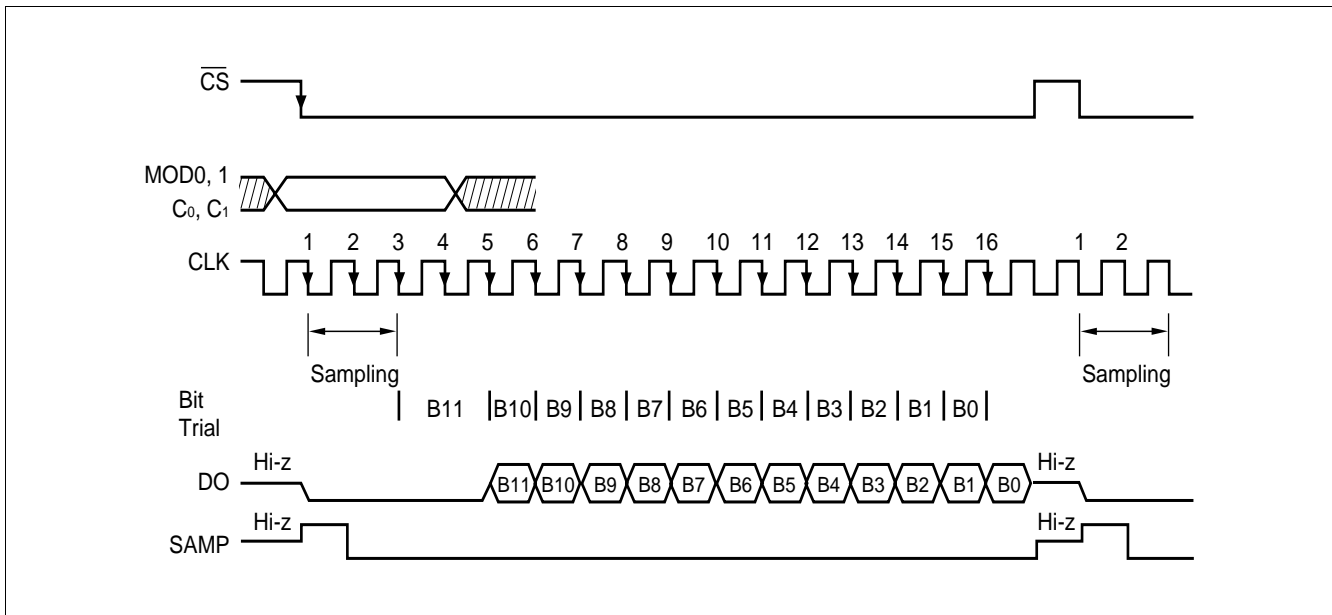

2. Mode 2

This mode continues conversion until \overline{CS} becomes “H” after it becomes “L”. Converted data is output from the LSB, with the first piece of converted data output 20 clock cycles after \overline{CS} becomes “L”. Changing the channel select pin settings before starting sampling of one analog input allows another to be converted.

• Timing diagram

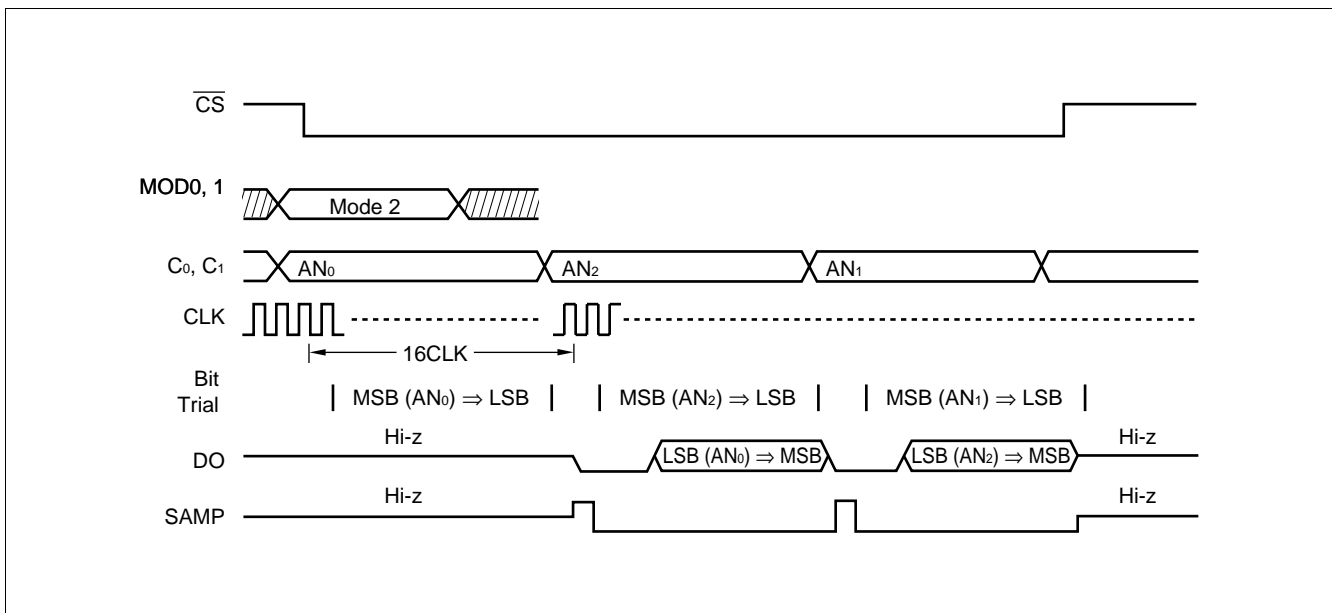

MB88101A

3. Mode 3

This mode continues conversion until \overline{CS} becomes "H" after it becomes "L". Converted data is output from the MSB. Changing the channel select pin settings before starting sampling of one analog input allows another to be converted.

- Timing diagram

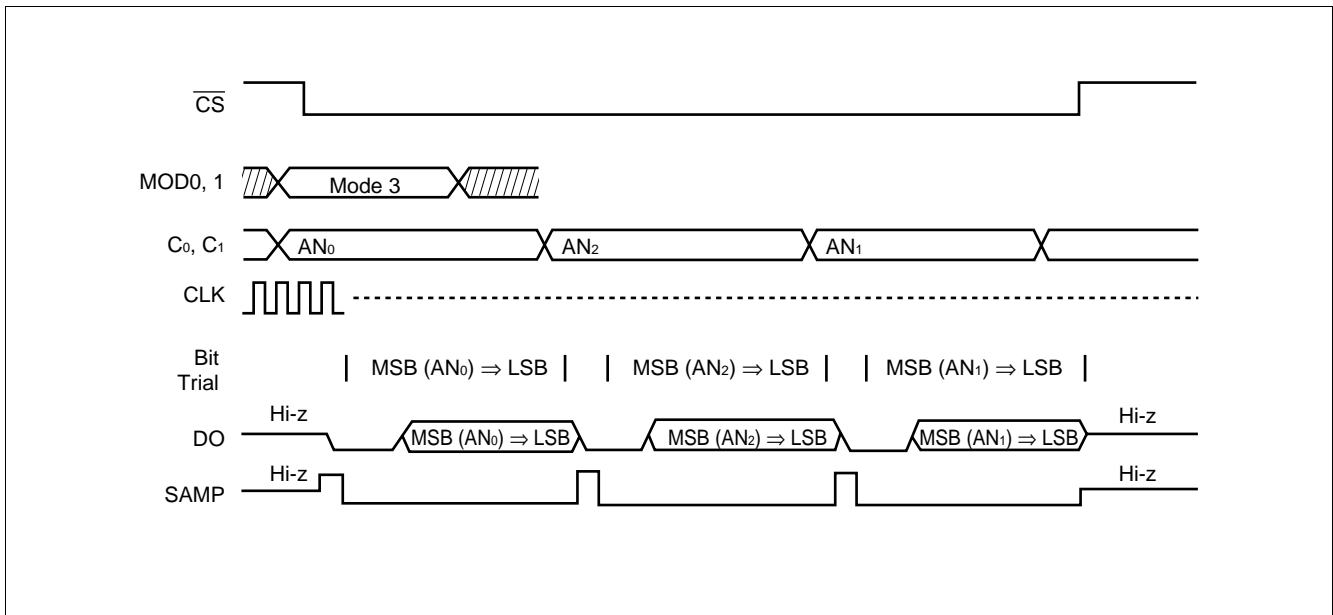

■ ABSOLUTE MAXIMUM RATINGS

| Parameter | Symbol | Conditions | Rating | | Unit |
|-----------------------|------------------|------------------------------|--------|-----------------------|------|
| | | | Min. | Max. | |
| Power supply voltage | V _{CC} | Based on GND (Ta = +25°C) | -0.3 | +7.0 | V |
| | V _{REF} | | -0.3* | +7.0* | V |
| Input voltage | V _{IN} | | -0.3 | V _{CC} + 0.3 | V |
| Output voltage | V _{OUT} | | -0.3 | V _{CC} + 0.3 | V |
| Power consumption | P _D | — | — | 150 | mW |
| Operating temperature | Ta | — | -20 | +85 | °C |
| Storage temperature | T _{stg} | — | -55 | +150 | °C |

* : V_{CC} ≥ V_{REF}

WARNING: Semiconductor devices can be permanently damaged by application of stress (voltage, current, temperature, etc.) in excess of absolute maximum ratings. Do not exceed these ratings.

■ RECOMMENDED OPERATING CONDITIONS

| Parameter | Symbol | Value | | | Unit |
|-----------------------|-----------------|-------|------|------|------|
| | | Min. | Typ. | Max. | |
| Power supply voltage | V _{CC} | 3.3 | — | 5.5 | V |
| | GND | — | 0 | — | V |
| Operation temperature | Ta | -20 | — | +85 | °C |

WARNING: Recommended operating conditions are normal operating ranges for the semiconductor device. All the device's electrical characteristics are warranted when operated within these ranges.

Always use semiconductor devices within the recommended operating conditions. Operation outside these ranges may adversely affect reliability and could result in device failure.

No warranty is made with respect to uses, operating conditions, or combinations not represented on the data sheet. Users considering application outside the listed conditions are advised to contact their FUJITSU representative beforehand.

MB88101A

■ ELECTRICAL CHARACTERISTIC

1. DC Characteristics

(1) Digital section

($V_{CC} = 3.3\text{ V to }5.5\text{ V}$, $D_{GND} = 0\text{ V}$, $T_a = -20^\circ\text{C to }+85^\circ\text{C}$)

| Parameter | Symbol | Pin name | Conditions | Value | | | Unit |
|---------------------------------------|-----------|---|--|----------------|------|----------------|---------------|
| | | | | Min. | Typ. | Max. | |
| Power supply voltage | V_{CC} | | — | 3.3 | 5.0 | 5.5 | V |
| Power supply current | I_{CC} | V_{CC} | Operation at CLK = 166kHz (with no load) | — | 0.8 | 2.0 | mA |
| Input leakage current | I_{ILK} | MOD0, 1 CLK \overline{CS} C_0 C_1 | $V_{IN} = 0\text{ to }V_{CC}$ | -10 | — | 10 | μA |
| Low-level input voltage | V_{IL} | | — | $V_{SS} - 0.3$ | — | $0.2 V_{CC}$ | V |
| High-level input voltage | V_{IH} | | — | $0.8 V_{CC}$ | — | $V_{CC} + 0.3$ | V |
| High-impedance output leakage current | I_{OLZ} | DO SAMP | $V_{IN} = 0\text{ to }V_{CC}$ | -10 | — | 10 | μA |
| Low-level output voltage | V_{OL} | | $I_{OL} = 2.5\text{ mA}$ | — | — | 0.4 | V |
| High-level output voltage | V_{OH} | | $I_{OH} = -400\ \mu\text{A}$ | $V_{CC} - 0.4$ | — | — | V |

(2) Analog section

($V_{REF}, V_{CC} = 3.3\text{ V to }5.5\text{ V}$ ($V_{CC} \geq V_{REF}$), $A_{GND} = 0\text{ V}$, $T_a = -20^\circ\text{C to }+85^\circ\text{C}$)

| Parameter | Symbol | Pin name | Value | | | Unit |
|------------------------------|-----------|------------------------------------|-------|------|-----------|---------------|
| | | | Min. | Typ. | Max. | |
| Resolution | — | AN ₀ to AN ₃ | — | 12 | — | bits |
| Linearity error | — | | -4.0 | — | 2.0 | LSB |
| Differential linearity error | — | | -1.0 | — | 3.0 | LSB |
| Conversion time | — | — | — | 16 | — | CLK |
| Consumption current | I_{REF} | V_{REF} | — | 100 | 300 | μA |
| Analog reference voltage | — | | 3.3 | 5.0 | V_{CC} | V |
| Analog input voltage | — | AN ₀ to AN ₃ | 0 | — | V_{REF} | V |

(3) Definitions of A/D converter terms

- Resolution
Analog transition identifiable by the A/D converter
- Linearity error
Deviation of the straight line drawn between the zero transition point (0000 0000 0000 ↔ 0000 0000 0001) and the full-scale transition point (1111 1111 1110 ↔ 1111 1111 1111) of the device from actual conversion characteristics
- Differential linearity error
Deviation from the ideal input voltage required to shift output code by one LSB

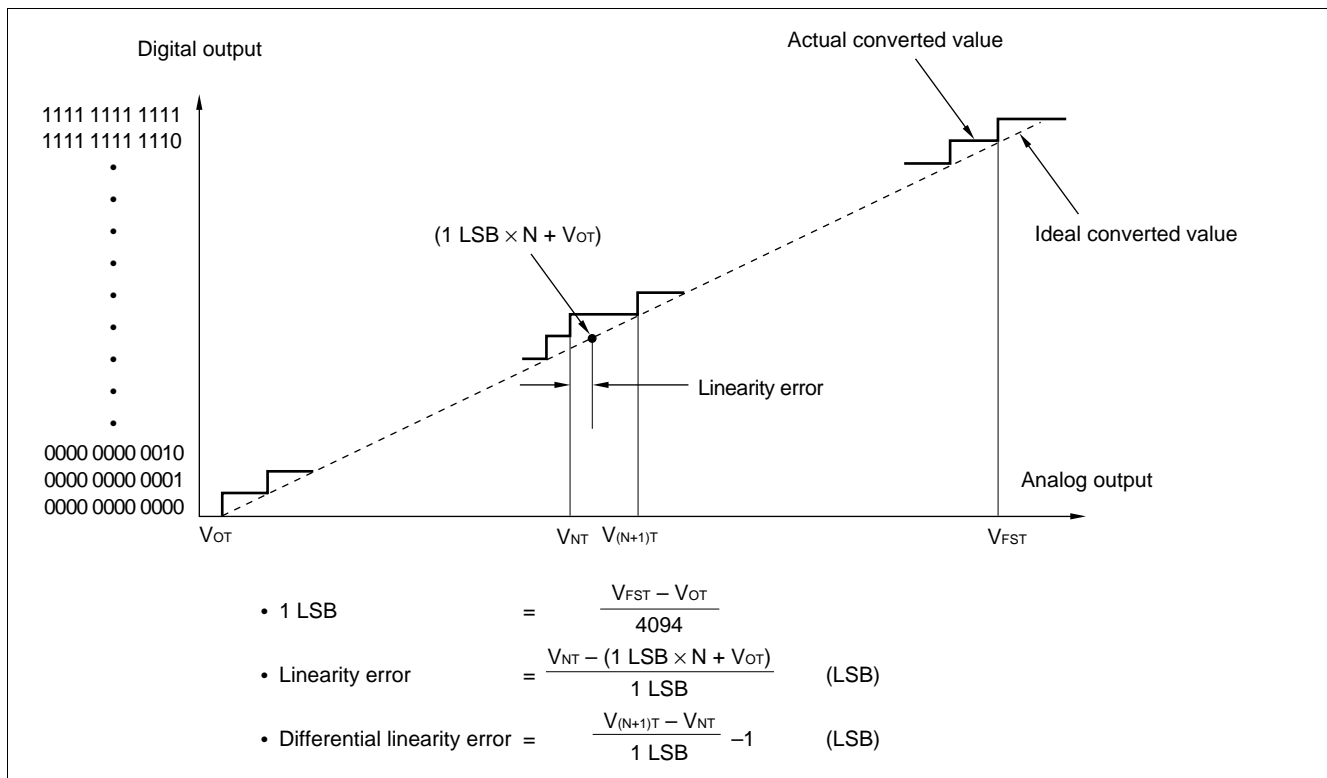

• Analog input equivalent circuit

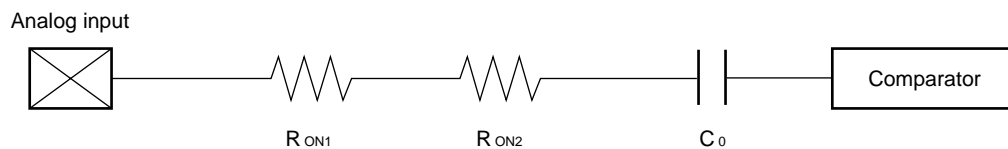

- R_{ON1} = About 1.5 k Ω
- R_{ON2} = About 1.5 k Ω
- C_0 = About 60 pF

Note: The above values are reference values.

- Notes:
- The tolerance of output impedance of an external circuit connected to this A/D converter has an effect on conversion time (CLK frequency). See "■ TYPICAL CHARACTERISTICS".
 - If the output impedance of the external input is too high, the analog voltage sampling time may be short.
 - When turning the device on, turn the power supply for the digital system first before turning V_{REF} on.

MB88101A

2. AC Characteristics

($V_{REF}, V_{CC} = 3.3\text{ V to }+5.5\text{ V}$ ($V_{CC} \geq V_{REF}$), $A_{GND} = 0\text{ V}$, $T_a = -20^\circ\text{C to }+85^\circ\text{C}$)

| Parameter | Symbol | Conditions | Value | | Unit |
|-----------------------------------|-----------|-----------------------------------|-----------------|------|---------------|
| | | | Min. | Max. | |
| Clock cycle time | t_{CLK} | $V_{CC} = 5\text{ V} \pm 10\%$ *1 | 1.0 | 30.0 | μs |
| | | — | 6.0 | 30.0 | μs |
| Low-level clock pulse width | t_{CKL} | — | 2.8 | 14.8 | μs |
| High-level clock pulse width | t_{CKH} | — | 2.8 | 14.8 | μs |
| Clock rise time | t_{Cr} | — | — | 0.2 | μs |
| Clock fall time | t_{Cf} | — | — | 0.2 | μs |
| \overline{CS} setup time | t_{CSS} | — | $t_{CKL} + 0.4$ | — | μs |
| \overline{CS} hold time | t_{CSH} | — | 1.0 | — | μs |
| \overline{CS} release time | t_{CSR} | — | 1.0 | — | CLK |
| Channel setup time | t_{CHS} | — | 0 | — | μs |
| Channel hold time | t_{CHH} | — | 1.0 | — | CLK |
| Data output delay time | t_{DO} | *2 | — | 0.5 | μs |
| MOD setup time | t_{MOS} | — | 0.2 | — | μs |
| MOD hold time | t_{MOH} | — | 0.1 | — | μs |
| Data active delay time | t_{DVE} | — | — | 0.5 | μs |
| Data float delay time | t_{DZE} | — | — | 0.5 | μs |
| SAMP active delay time | t_{SVE} | — | — | 0.5 | μs |
| SAMP float delay time | t_{SZE} | — | — | 0.5 | μs |
| SAMP high-level output delay time | t_{SHD} | *2 | — | 0.5 | μs |
| SAMP low-level output delay time | t_{SLD} | *2 | — | 0.5 | μs |

*1: Depending on the output impedance of the external circuit connected to the analog input pin

*2: See “• AC test circuit.”

• AC test circuit

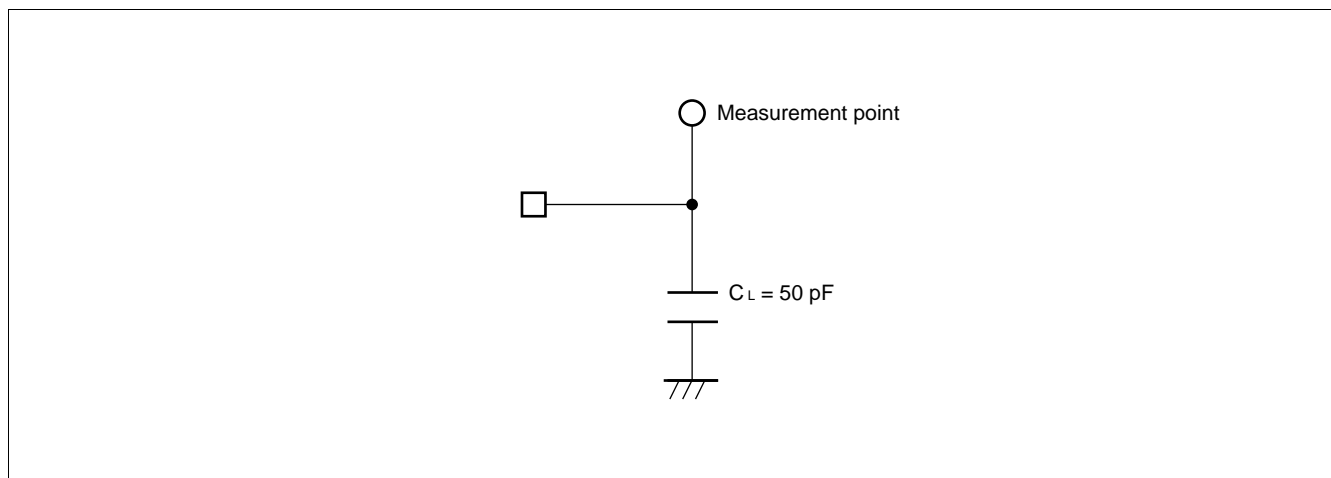

■ TIMING DIAGRAM

(1) Input clock timing

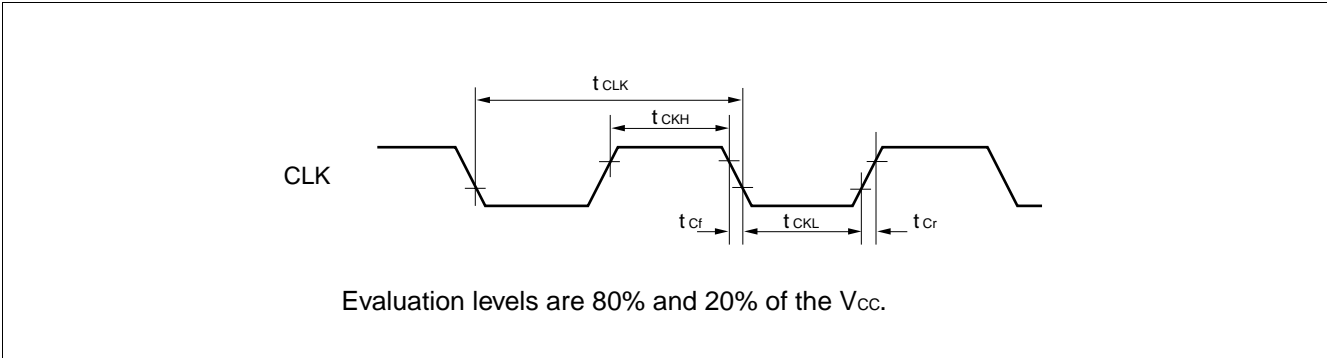

(2) A/D startup timing

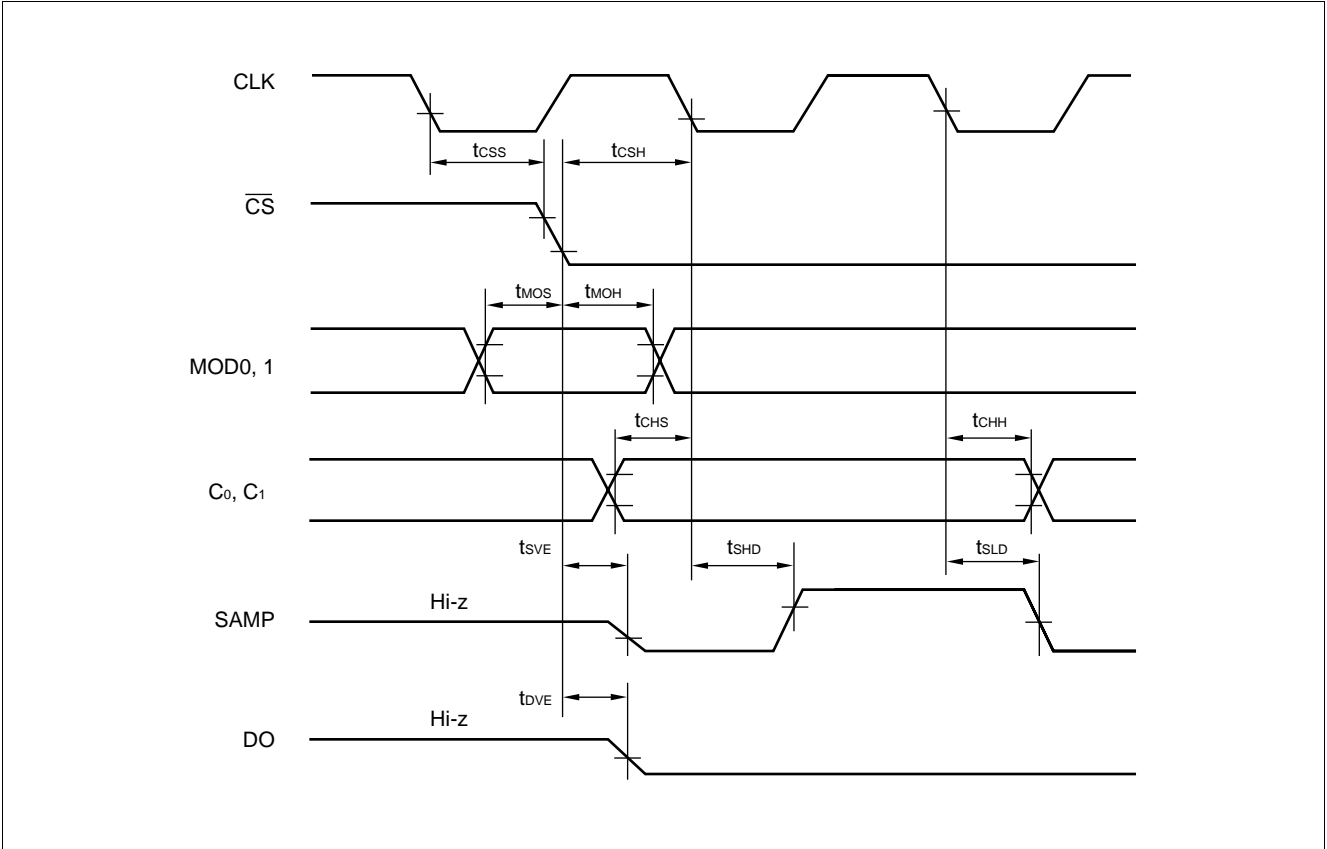

MB88101A

(3) Data output delay time and A/D stop timing

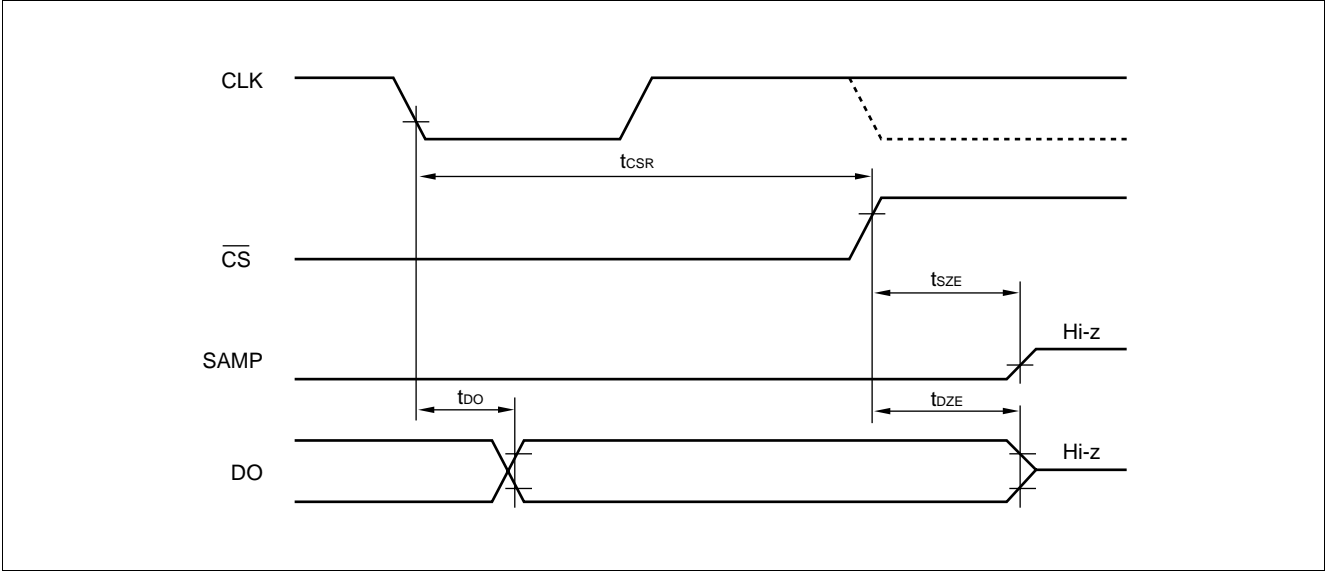

■ TYPICAL CHARACTERISTICS

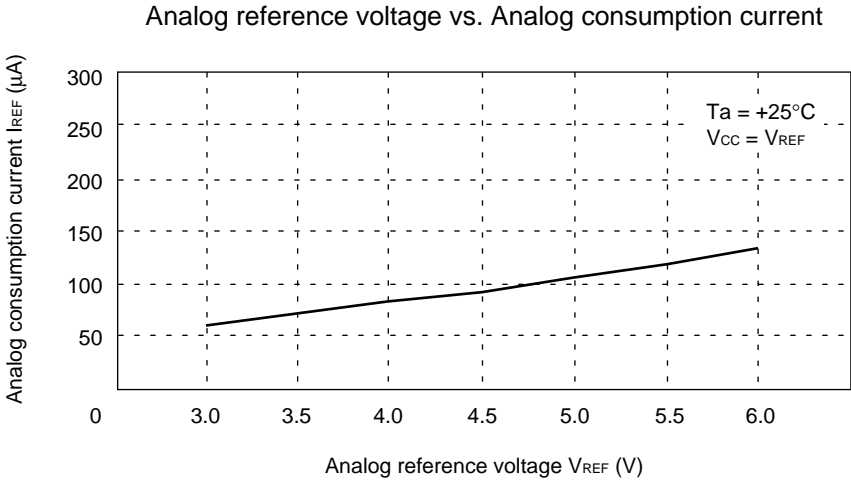
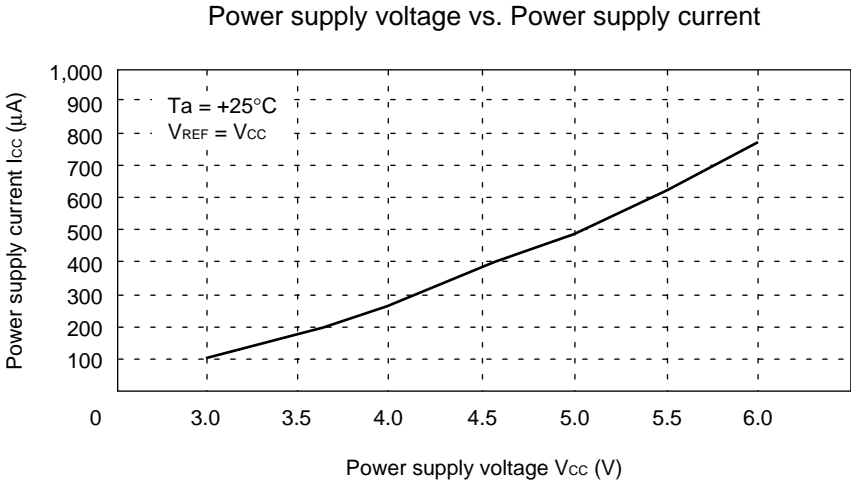

MB88101A

Analog input external impedance vs. Clock cycle time (t_{CLK})

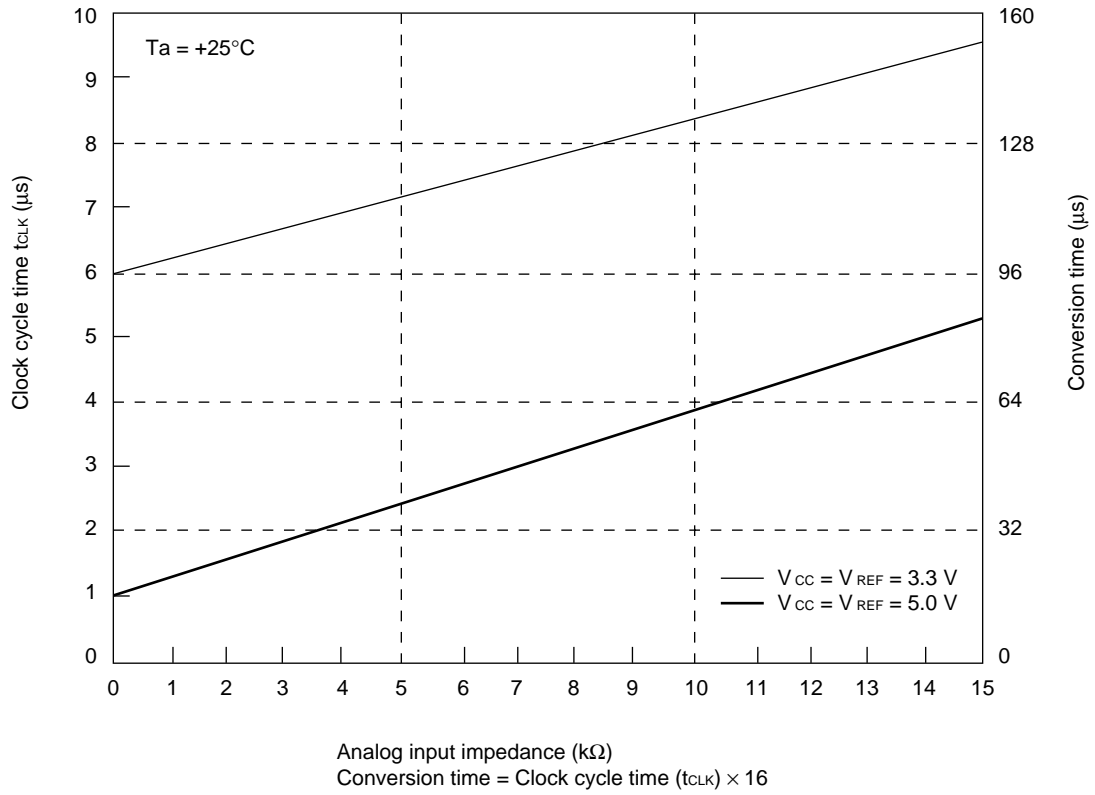

MB88101A

■ ORDERING INFORMATION

| Part number | Package | Remarks |
|-------------|--------------------------------------|---------|
| MB88101AP | 16-pin Plastic DIP (DIP-16P-M04) | |
| MB88101APFV | 16-pin Plastic SSOP (FPT-16P-M05) | |
| MB88101APF | 16-pin Plastic SOP (FPT-16P-M06) | |

MB88101A

PACKAGE DIMENSIONS

16-pin Plastic DIP
(DIP-16P-M04)

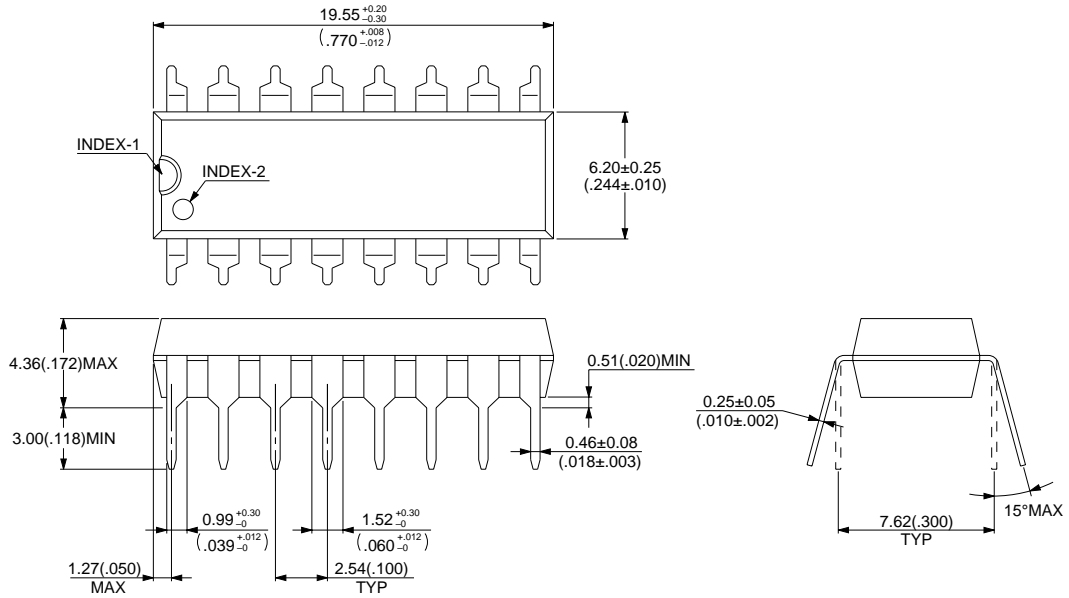

© 1994 FUJITSU LIMITED D16033S-2C-3

Dimensions in mm (inches)

16-pin Plastic SSOP
(FPT-16P-M05)

*: This dimension do not include resin protrusion.

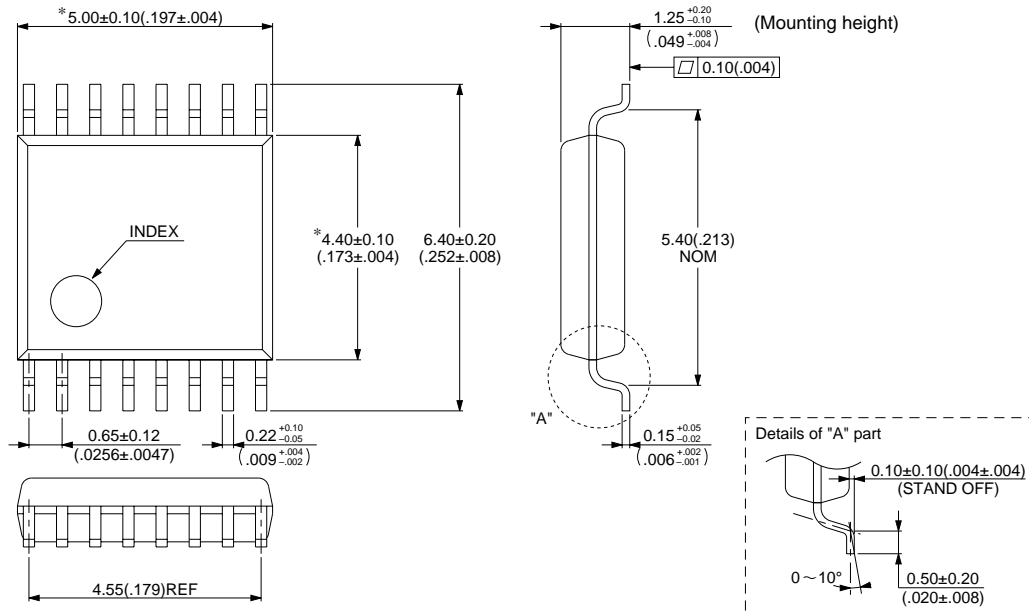

© 1994 FUJITSU LIMITED F16013S-2C-4

Dimensions in mm (inches)

MB88101A

16-pin Plastic SOP (FPT-16P-M06)

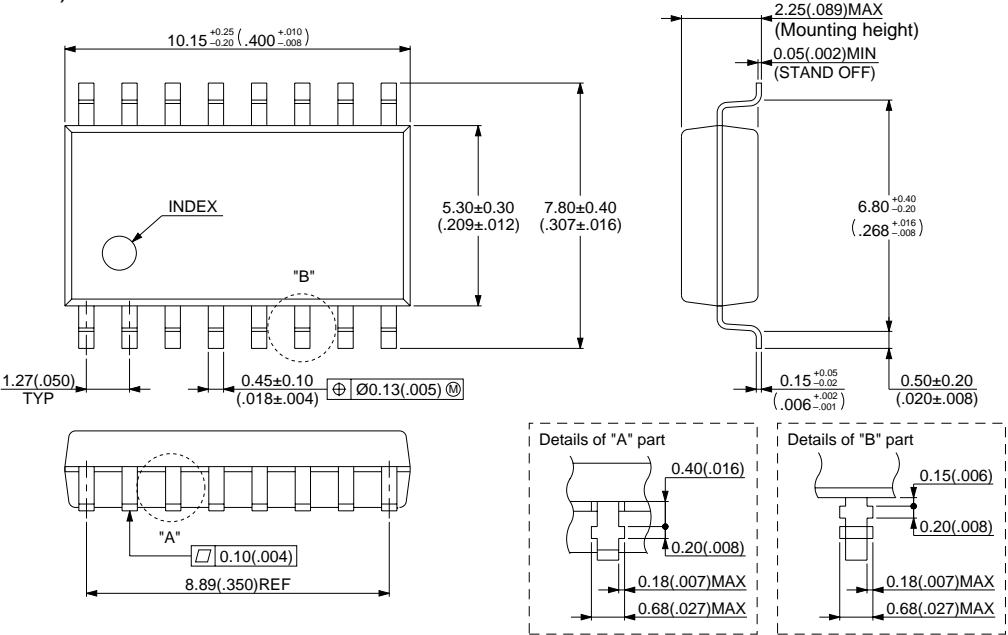

MB88101A

FUJITSU LIMITED

For further information please contact:

Japan

FUJITSU LIMITED
Corporate Global Business Support Division
Electronic Devices
KAWASAKI PLANT, 4-1-1, Kamikodanaka
Nakahara-ku, Kawasaki-shi
Kanagawa 211-8588, Japan
Tel: (044) 754-3763
Fax: (044) 754-3329

<http://www.fujitsu.co.jp/>

North and South America

FUJITSU MICROELECTRONICS, INC.
Semiconductor Division
3545 North First Street
San Jose, CA 95134-1804, USA
Tel: (408) 922-9000
Fax: (408) 922-9179

Customer Response Center
Mon. - Fri.: 7 am - 5 pm (PST)
Tel: (800) 866-8608
Fax: (408) 922-9179

<http://www.fujitsumicro.com/>

Europe

FUJITSU MIKROELEKTRONIK GmbH
Am Siebenstein 6-10
D-63303 Dreieich-Buchsschlag
Germany
Tel: (06103) 690-0
Fax: (06103) 690-122

<http://www.fujitsu-edc.com/>

Asia Pacific

FUJITSU MICROELECTRONICS ASIA PTE LTD
#05-08, 151 Lorong Chuan
New Tech Park
Singapore 556741
Tel: (65) 281-0770
Fax: (65) 281-0220

<http://www.fmap.com.sg/>

F9802

© FUJITSU LIMITED Printed in Japan

All Rights Reserved.

The contents of this document are subject to change without notice. Customers are advised to consult with FUJITSU sales representatives before ordering.

The information and circuit diagrams in this document presented as examples of semiconductor device applications, and are not intended to be incorporated in devices for actual use. Also, FUJITSU is unable to assume responsibility for infringement of any patent rights or other rights of third parties arising from the use of this information or circuit diagrams.

FUJITSU semiconductor devices are intended for use in standard applications (computers, office automation and other office equipment, industrial, communications, and measurement equipment, personal or household devices, etc.).

CAUTION:

Customers considering the use of our products in special applications where failure or abnormal operation may directly affect human lives or cause physical injury or property damage, or where extremely high levels of reliability are demanded (such as aerospace systems, atomic energy controls, sea floor repeaters, vehicle operating controls, medical devices for life support, etc.) are requested to consult with FUJITSU sales representatives before such use. The company will not be responsible for damages arising from such use without prior approval.

Any semiconductor devices have inherently a certain rate of failure. You must protect against injury, damage or loss from such failures by incorporating safety design measures into your facility and equipment such as redundancy, fire protection, and prevention of over-current levels and other abnormal operating conditions.

If any products described in this document represent goods or technologies subject to certain restrictions on export under the Foreign Exchange and Foreign Trade Control Law of Japan, the prior authorization by Japanese government should be required for export of those products from Japan.