



## SPX2811

### 10A Low Dropout Voltage Regulator Fast Response, Adjustable & Fixed

#### FEATURES

- Adjustable Output Down To 1.2V
- Output Current Of 10A
- Low Dropout Voltage 1.1V Typ
- Extremely Tight Load And Line Regulation
- Current & Thermal Limiting
- Standard 3-Terminal Low Cost TO-220
- Similar To Industry Standard LT1584

#### APPLICATIONS

- Powering Intel Pentium™  $\mu$ P from +5V Supplies
- Power PC™ Supplies
- SMPS Post-Regulator
- High Efficiency “Green” Computer Systems
- High Efficiency Linear Power Supplies
- Portable Instrumentation
- Constant Current Regulators
- Adjustable Power Supplies
- Battery Charger

#### PRODUCT DESCRIPTION

The SPX2811 is a low power 10A adjustable and fixed voltage regulator that is very easy to use. It requires only two external resistors to set the output voltage for the adjustable version. The SPX2811 is designed for low voltage applications that offer lower dropout voltage and faster transient response. This device is an excellent choice for use in powering low voltage Microprocessor that require a lower dropout, faster transient response to regulate from +2.5V to 3.8V supplies and as a post regulator for switching supplies applications. The SPX2811 features low dropout of a maximum 1.2 volts.

The SPX2811 offers full protection against over-current faults, reversed input polarity, reversed load insertion, and positive and negative transient voltage. On-Chip trimming adjusts the reference voltage to 1%. The  $I_Q$  of this device flows into the load which increases efficiency.

The SPX2811 is offered in a 3-Pin TO-220 and TO-263 package type, compatible with older 3 terminal regulators. For a 8A low dropout regulator refer to the SPX1584 datasheet.

#### PIN CONNECTIONS

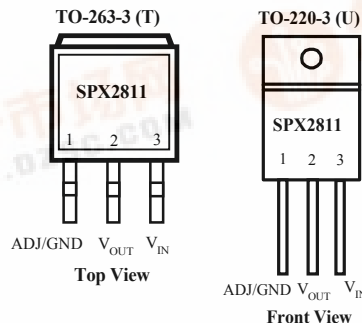

# SPX2811

## ABSOLUTE MAXIMUM RATINGS

Lead Temp. (Soldering, 10 Seconds) .....	300°C
Storage Temperature Range .....	-65° to +150°C
Operating Junction Temperature Range	
SPX2811 Control Section.....	0°C to +125°C
SPX2811 Power Transistor.....	0°C to +150°C

Operating Input Voltage ..... 7V

## ELECTRICAL CHARACTERISTICS (NOTE 1) at $I_{OUT} = 10\text{mA}$ , $T_a = 25^\circ\text{C}$ , unless otherwise specified.

Parameter	Conditions	SPX2811			Units
		Min	Typ	Max	
<b>3.3V Version</b>					
Output Voltage	SPX2811-3.3V, $0 \leq I_{OUT} \leq 1.5\text{A}$ , $4.75\text{V} \leq V_{IN} \leq 7\text{V}$	3.270 <b>3.240</b>	3.3	3.330 <b>3.360</b>	V
Reference Voltage	SPX2811- $1.5\text{V} \leq (V_{IN} - V_{OUT}) \leq 3\text{V}$ , $10\text{mA} \leq I_{OUT} \leq 7\text{A}$	1.238 <b>1.225</b>	1.250	1.262 <b>1.275</b>	V
Output Voltage	SPX2811-3.3, $0 \leq I_{OUT} \leq 5\text{A}$ , $4.75\text{V} \leq V_{IN} \leq 7\text{V}$ Note 4	3.270 <b>3.235</b>	3.300	3.330 <b>3.365</b>	V
Min. Load Current	$1.5\text{V} \leq (V_{IN} - V_{OUT}) \leq 5.75\text{V}$		<b>5</b>	<b>10</b>	mA
Line Regulation	SPX2811- $2.75\text{V} \leq V_{IN} \leq 7\text{V}$ , $I_{OUT} = 10\text{mA}$ , $T_J = 25^\circ\text{C}$		0.005 <b>0.005</b>	0.2 <b>0.2</b>	%
	SPX2811-3.3, $4.75\text{V} \leq V_{IN} \leq 7\text{V}$ , $I_{OUT} = 0\text{mA}$ , $T_J = 25^\circ\text{C}$		0.005 <b>0.005</b>	0.2 <b>0.2</b>	
Load Regulation	SPX2811, $10 \leq I_{OUT} \leq I_{FLA}$ , $(V_{IN} - V_{OUT}) = 3\text{V}$ , $T_J = 25^\circ\text{C}$		0.05 <b>0.005</b>	0.3 <b>0.5</b>	%
	SPX2811-3.3, $0 \leq I_{OUT} \leq I_{FLA}$ , $V_{IN} = 5\text{V}$ , $T_J = 25^\circ\text{C}$		0.05 <b>0.005</b>	0.3 <b>0.5</b>	
Dropout Voltage	$I_{OUT} = I_{FULLLOAD}$ , $\Delta V_{REF} = 1\%$		<b>1.1</b>	<b>1.2</b>	V
Current Limit	SPX2811, $V_{IN} = 7\text{V}$	<b>11.0</b>	<b>12.0</b>		A
Long Term Stability	$T_A = 125^\circ\text{C}$ , 1000Hrs.		0.3	1	%
Thermal Regulation	SPX2811, 30ms pulse		0.004	0.020	%/W
Temperature Stability			<b>0.5</b>		%
Output Noise, RMS	10Hz to 10kHz		0.003		% $V_O$
Thermal Resistance Junction-to-Case	TO-220	Control Section		0.65	°C/W
		Power Transistor		2.7	
	TO-263	Control Section		0.65	
		Power Transistor		2.7	

The Bold specifications apply to the full operating temperature range.

Note 1: Changes in output voltage due to heating effects are covered under the specification for thermal regulation.

Note 2: A 10 $\mu\text{F}$  output capacitor is required on SPX2811.

## TYPICAL CHARACTERISTICS

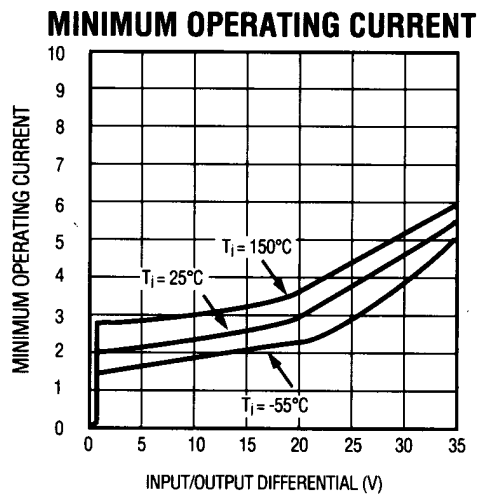
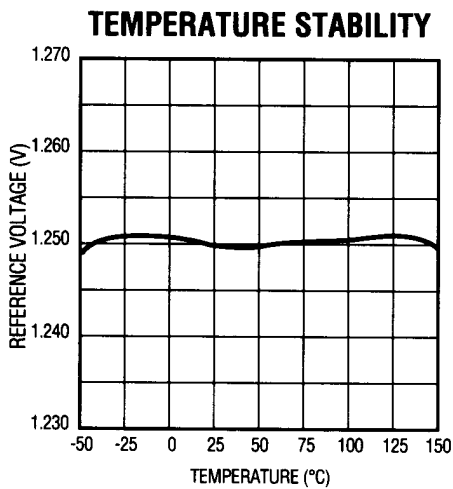
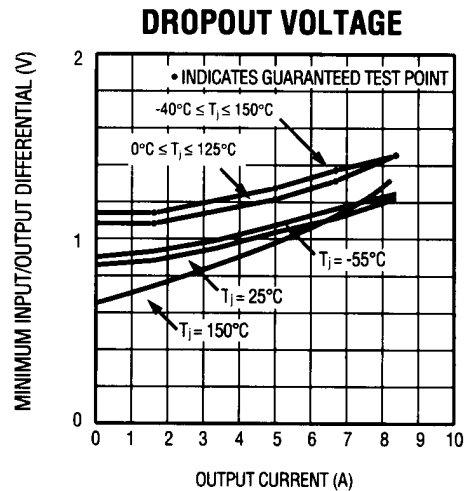
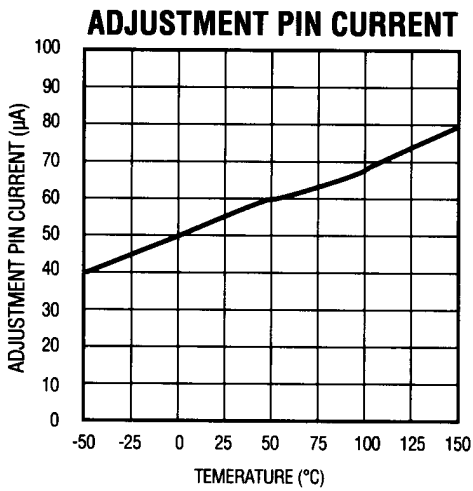
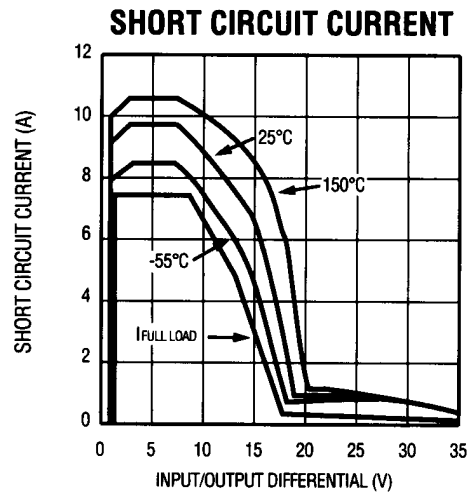
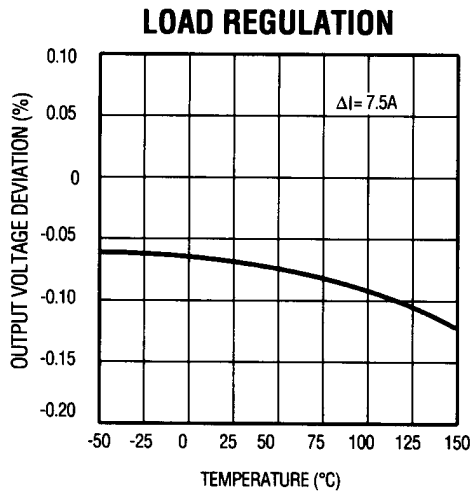

## TYPICAL APPLICATIONS

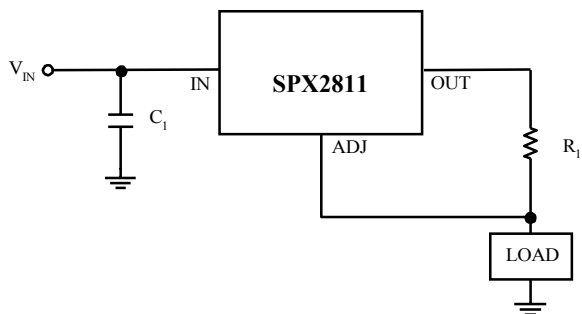

**10A Current Output Regulator**

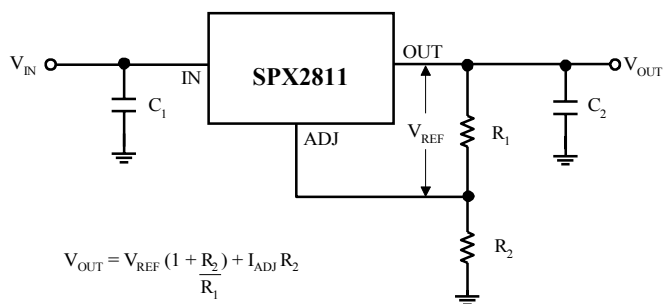

**Typical Adjustable Regulator**

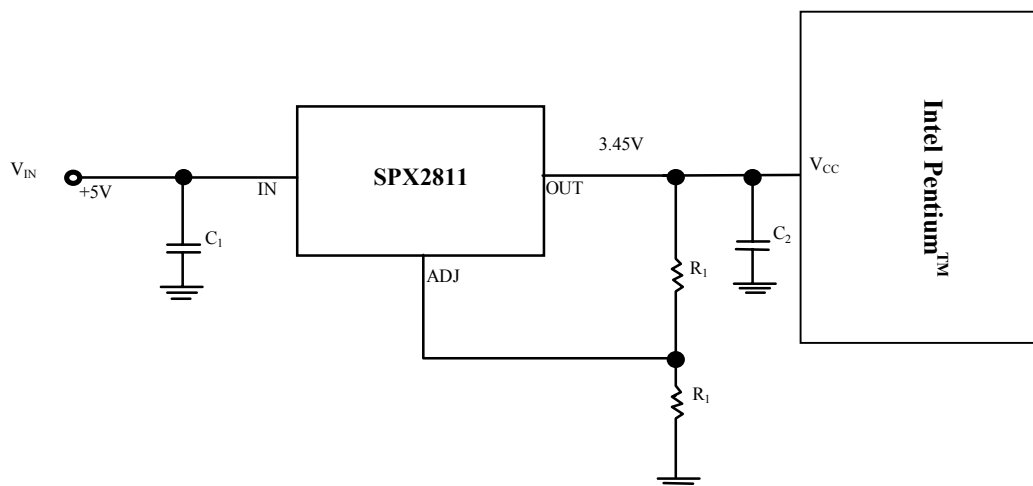

**Powering Intel Pentium™ with SPX2811**

Pentium Processor is a trademark of Intel Corp. Power PC is a trademark of IBM Corp.

## ORDERING INFORMATION

Ordering No.	Precision	Output Voltage	Packages
SPX2811AU	1%	Adj	3 Lead TO-220
SPX2811AU-3.3	1%	3.3V	3 Lead TO-220
SPX2811AT	1%	Adj	3 Lead TO-263
SPX2811AT-3.3	1%	3.3V	3 Lead TO-263



SIGNAL PROCESSING EXCELLENCE

### Sipex Corporation

**Headquarters and Main Offices:**

22 Linnell Circle  
Billerica, MA 01821  
TEL: (978) 667-8700  
FAX: (978) 670-9001  
e-mail: sales@sipex.com

233 South Hillview Drive  
Milpitas, CA 95035  
TEL: (408) 935-7600  
FAX: (408) 934-7500