



# CY7C1041BV33

## 256K x 16 Static RAM

### Features

- **High speed**  
—  $t_{AA} = 12 \text{ ns}$
- **Low active power**  
— 612 mW (max.)
- **Low CMOS standby power (Commercial L version)**  
— 1.8 mW (max.)
- **2.0V Data Retention (600  $\mu\text{W}$  at 2.0V retention)**
- **Automatic power-down when deselected**
- **TTL-compatible inputs and outputs**
- **Easy memory expansion with  $\overline{\text{CE}}$  and  $\overline{\text{OE}}$  features**

### Functional Description

The CY7C1041BV33 is a high-performance CMOS Static RAM organized as 262,144 words by 16 bits.

Writing to the device is accomplished by taking Chip Enable ( $\overline{\text{CE}}$ ) and Write Enable ( $\overline{\text{WE}}$ ) inputs LOW. If Byte Low Enable ( $\overline{\text{BLE}}$ ) is LOW, then data from I/O pins (I/O<sub>0</sub> through I/O<sub>7</sub>), is

written into the location specified on the address pins (A<sub>0</sub> through A<sub>17</sub>). If Byte High Enable ( $\overline{\text{BHE}}$ ) is LOW, then data from I/O pins (I/O<sub>8</sub> through I/O<sub>15</sub>) is written into the location specified on the address pins (A<sub>0</sub> through A<sub>17</sub>).

Reading from the device is accomplished by taking Chip Enable ( $\overline{\text{CE}}$ ) and Output Enable ( $\overline{\text{OE}}$ ) LOW while forcing the Write Enable ( $\overline{\text{WE}}$ ) HIGH. If Byte Low Enable ( $\overline{\text{BLE}}$ ) is LOW, then data from the memory location specified by the address pins will appear on I/O<sub>0</sub> to I/O<sub>7</sub>. If Byte High Enable ( $\overline{\text{BHE}}$ ) is LOW, then data from memory will appear on I/O<sub>8</sub> to I/O<sub>15</sub>. See the truth table at the back of this data sheet for a complete description of read and write modes.

The input/output pins (I/O<sub>0</sub> through I/O<sub>15</sub>) are placed in a high-impedance state when the device is deselected ( $\overline{\text{CE}}$  HIGH), the outputs are disabled ( $\overline{\text{OE}}$  HIGH), the  $\overline{\text{BHE}}$  and  $\overline{\text{BLE}}$  are disabled ( $\overline{\text{BHE}}$ ,  $\overline{\text{BLE}}$  HIGH), or during a write operation ( $\overline{\text{CE}}$  LOW, and  $\overline{\text{WE}}$  LOW).

The CY7C1041BV33 is available in a standard 44-pin 400-mil-wide body width SOJ and 44-pin TSOP II package with center power and ground (revolutionary) pinout.

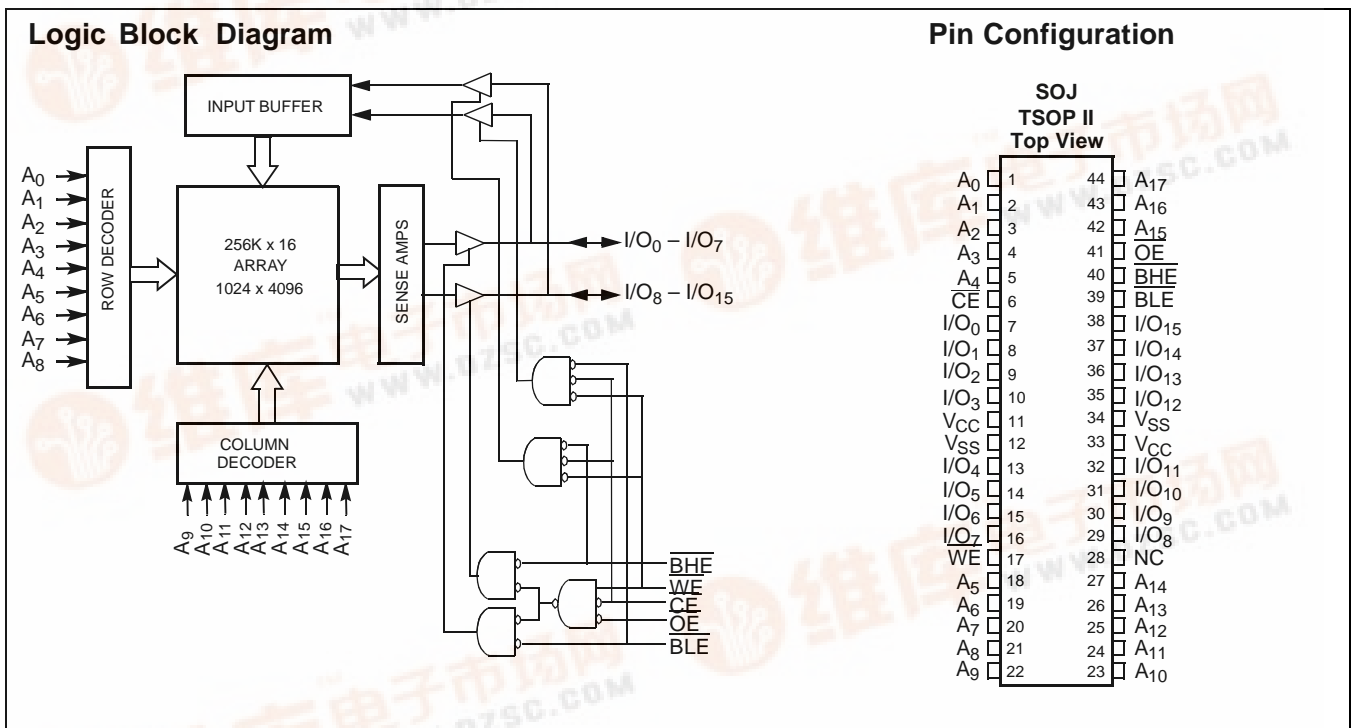

### Selection Guide

		-12	-15	-17	-20	-25
Maximum Access Time (ns)		12	15	17	20	25
Maximum Operating Current (mA)	Comm'l	190	170	160	150	130
	Ind'l	-	190	180	170	150
Maximum CMOS Standby Current (mA)	Com'l/Ind'l	8	8	8	8	8
	Com'l L	0.5	0.5	0.5	0.5	0.5



**Maximum Ratings**

(Above which the useful life may be impaired. For user guidelines, not tested.)

Storage Temperature ..... -65°C to +150°C

Ambient Temperature with Power Applied..... -55°C to +125°C

Supply Voltage on V<sub>CC</sub> to Relative GND<sup>[1]</sup> .... -0.5V to +4.6V

DC Voltage Applied to Outputs in High Z State<sup>[1]</sup> ..... -0.5V to V<sub>CC</sub> + 0.5V

DC Input Voltage<sup>[1]</sup> ..... -0.5V to V<sub>CC</sub> + 0.5V

Current into Outputs (LOW) ..... 20 mA

**Operating Range**

Range	Ambient Temperature <sup>[2]</sup>	V <sub>CC</sub>
Commercial	0°C to +70°C	3.3V ± 0.3V
Industrial	-40°C to +85°C	

**Electrical Characteristics** Over the Operating Range

Parameter	Description	Test Conditions	-12		-15		Unit	
			Min.	Max.	Min.	Max.		
V <sub>OH</sub>	Output HIGH Voltage	V <sub>CC</sub> = Min., I <sub>OH</sub> = -4.0 mA	2.4		2.4		V	
V <sub>OL</sub>	Output LOW Voltage	V <sub>CC</sub> = Min., I <sub>OL</sub> = 8.0 mA		0.4		0.4	V	
V <sub>IH</sub>	Input HIGH Voltage		2.2	V <sub>CC</sub> + 0.5	2.2	V <sub>CC</sub> + 0.5	V	
V <sub>IL</sub>	Input LOW Voltage <sup>[1]</sup>		-0.5	0.8	-0.5	0.8	V	
I <sub>IX</sub>	Input Load Current	GND ≤ V <sub>I</sub> ≤ V <sub>CC</sub>	-1	+1	-1	+1	μA	
I <sub>OZ</sub>	Output Leakage Current	GND ≤ V <sub>OUT</sub> ≤ V <sub>CC</sub> , Output Disabled	-1	+1	-1	+1	μA	
I <sub>CC</sub>	V <sub>CC</sub> Operating Supply Current	V <sub>CC</sub> = Max., f = f <sub>MAX</sub> = 1/t <sub>RC</sub>	Comm'l			190	170	mA
			Ind'l			-	190	mA
I <sub>SB1</sub>	Automatic CE Power-Down Current —TTL Inputs	Max. V <sub>CC</sub> , $\overline{CE} \geq V_{IH}$ V <sub>IN</sub> ≥ V <sub>IH</sub> or V <sub>IN</sub> ≤ V <sub>IL</sub> , f = f <sub>MAX</sub>		40		40	mA	
I <sub>SB2</sub>	Automatic CE Power-Down Current —CMOS Inputs	Max. V <sub>CC</sub> , CE ≥ V <sub>CC</sub> - 0.3V, V <sub>IN</sub> ≥ V <sub>CC</sub> - 0.3V, or V <sub>IN</sub> ≤ 0.3V, f = 0	Com'l/Ind'l			8	8	mA
			Com'l	L		0.5	0.5	mA

**Notes:**

- V<sub>IL</sub> (min.) = -2.0V for pulse durations of less than 20 ns.
- T<sub>A</sub> is the "Instant On" case temperature.

**Electrical Characteristics** Over the Operating Range (continued)

Parameter	Description	Test Conditions	-17		-20		-25		Unit	
			Min.	Max.	Min.	Max.	Min.	Max.		
V <sub>OH</sub>	Output HIGH Voltage	V <sub>CC</sub> = Min., I <sub>OH</sub> = -4.0 mA	2.4		2.4		2.4		V	
V <sub>OL</sub>	Output LOW Voltage	V <sub>CC</sub> = Min., I <sub>OL</sub> = 8.0 mA		0.4		0.4		0.4	V	
V <sub>IH</sub>	Input HIGH Voltage		2.2	V <sub>CC</sub> + 0.5	2.2	V <sub>CC</sub> + 0.5	2.2	V <sub>CC</sub> + 0.5	V	
V <sub>IL</sub>	Input LOW Voltage <sup>[1]</sup>		-0.5	0.8	-0.5	0.8	-0.5	0.8	V	
I <sub>IX</sub>	Input Load Current	GND ≤ V <sub>I</sub> ≤ V <sub>CC</sub>	-1	+1	-1	+1	-1	+1	μA	
I <sub>OZ</sub>	Output Leakage Current	GND ≤ V <sub>OUT</sub> ≤ V <sub>CC</sub> , Output Disabled	-1	+1	-1	+1	-1	+1	μA	
I <sub>CC</sub>	V <sub>CC</sub> Operating Supply Current	V <sub>CC</sub> = Max., f = f <sub>MAX</sub> = 1/t <sub>RC</sub>	Comm'l		160		150		130	mA
			Ind'l		180		170		150	
I <sub>SB1</sub>	Automatic CE Power-Down Current — TTL Inputs	Max. V <sub>CC</sub> , CE ≥ V <sub>IH</sub> V <sub>IN</sub> ≥ V <sub>IH</sub> or V <sub>IN</sub> ≤ V <sub>IL</sub> , f = f <sub>MAX</sub>		40		40		40	mA	
I <sub>SB2</sub>	Automatic CE Power-Down Current — CMOS Inputs	Max. V <sub>CC</sub> , CE ≥ V <sub>CC</sub> - 0.3V, V <sub>IN</sub> ≥ V <sub>CC</sub> - 0.3V, or V <sub>IN</sub> ≤ 0.3V, f=0	Com'l/Ind'l		8		8		8	mA
			Com'l	L		0.5		0.5		0.5

**Capacitance<sup>[3]</sup>**

Parameter	Description	Test Conditions	Max.	Unit
C <sub>IN</sub>	Input Capacitance	T <sub>A</sub> = 25°C, f = 1 MHz, V <sub>CC</sub> = 3.3V	8	pF
C <sub>OUT</sub>	I/O Capacitance		8	pF

**Note:**

3. Tested initially and after any design or process changes that may affect these parameters.

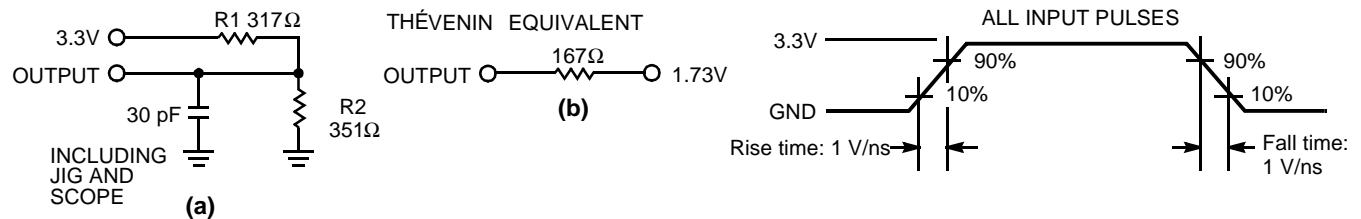
**AC Test Loads and Waveforms**

**Switching Characteristics<sup>[4]</sup> Over the Operating Range**

Parameter	Description	-12		-15		-17		Unit
		Min.	Max.	Min.	Max.	Min.	Max.	
<b>READ CYCLE</b>								
t <sub>RC</sub>	Read Cycle Time	12		15		17		ns
t <sub>AA</sub>	Address to Data Valid		12		15		17	ns
t <sub>OHA</sub>	Data Hold from Address Change	3		3		3		ns
t <sub>ACE</sub>	$\overline{CE}$ LOW to Data Valid		12		15		17	ns
t <sub>DOE</sub>	$\overline{OE}$ LOW to Data Valid		6		7		8	ns
t <sub>LZOE</sub>	$\overline{OE}$ LOW to Low Z	0		0		0		ns
t <sub>HZOE</sub>	$\overline{OE}$ HIGH to High Z <sup>[5, 6]</sup>		6		7		7	ns
t <sub>LZCE</sub>	$\overline{CE}$ LOW to Low Z <sup>[6]</sup>	3		3		3		ns
t <sub>HZCE</sub>	$\overline{CE}$ HIGH to High Z <sup>[5, 6]</sup>		6		7		7	ns
t <sub>PU</sub>	$\overline{CE}$ LOW to Power-Up	0		0		0		ns
t <sub>PD</sub>	$\overline{CE}$ HIGH to Power-Down		12		15		17	ns
t <sub>DBE</sub>	Byte Enable to Data Valid		6		7		7	ns
t <sub>LZBE</sub>	Byte Enable to Low Z	0		0		0		ns
t <sub>HZBE</sub>	Byte Disable to High Z		6		7		8	ns
<b>WRITE CYCLE<sup>[7, 8]</sup></b>								
t <sub>WC</sub>	Write Cycle Time	12		15		17		ns
t <sub>SCE</sub>	$\overline{CE}$ LOW to Write End	10		12		12		ns
t <sub>AW</sub>	Address Set-Up to Write End	10		12		12		ns
t <sub>HA</sub>	Address Hold from Write End	0		0		0		ns
t <sub>SA</sub>	Address Set-Up to Write Start	0		0		0		ns
t <sub>PWE</sub>	$\overline{WE}$ Pulse Width	10		12		12		ns
t <sub>SD</sub>	Data Set-Up to Write End	7		8		9		ns
t <sub>HD</sub>	Data Hold from Write End	0		0		0		ns
t <sub>LZWE</sub>	$\overline{WE}$ HIGH to Low Z <sup>[6]</sup>	3		3		3		ns
t <sub>HZWE</sub>	$\overline{WE}$ LOW to High Z <sup>[5, 6]</sup>		6		7		8	ns
t <sub>BW</sub>	Byte Enable to End of Write	10		12		12		ns

**Notes:**

- Test conditions assume signal transition time of 3 ns or less, timing reference levels of 1.5V, input pulse levels of 0 to 3.0V, and output loading of the specified I<sub>OL</sub>/I<sub>OH</sub> and 30-pF load capacitance.
- t<sub>HZOE</sub>, t<sub>HZCE</sub>, and t<sub>HZWE</sub> are specified with a load capacitance of 5 pF as in part (b) of AC Test Loads. Transition is measured ±500 mV from steady-state voltage.
- At any given temperature and voltage condition, t<sub>HZCE</sub> is less than t<sub>LZCE</sub>, t<sub>HZOE</sub> is less than t<sub>LZOE</sub>, and t<sub>HZWE</sub> is less than t<sub>LZWE</sub> for any given device.
- The internal write time of the memory is defined by the overlap of  $\overline{CE}$  LOW, and  $\overline{WE}$  LOW.  $\overline{CE}$  and  $\overline{WE}$  must be LOW to initiate a write, and the transition of either of these signals can terminate the write. The input data set-up and hold timing should be referenced to the leading edge of the signal that terminates the write.
- The minimum write cycle time for Write Cycle No. 3 ( $\overline{WE}$  controlled,  $\overline{OE}$  LOW) is the sum of t<sub>HZWE</sub> and t<sub>SD</sub>.

**Switching Characteristics<sup>[4]</sup>** Over the Operating Range (continued)

Parameter	Description	-20		-25		Unit
		Min.	Max.	Min.	Max.	
<b>READ CYCLE</b>						
$t_{RC}$	Read Cycle Time	20		25		ns
$t_{AA}$	Address to Data Valid		20		25	ns
$t_{OHA}$	Data Hold from Address Change	3		5		ns
$t_{ACE}$	$\overline{CE}$ LOW to Data Valid		20		25	ns
$t_{DOE}$	$\overline{OE}$ LOW to Data Valid		8		10	ns
$t_{LZOE}$	$\overline{OE}$ LOW to Low Z	0		0		ns
$t_{HZOE}$	$\overline{OE}$ HIGH to High Z <sup>[5, 6]</sup>		8		10	ns
$t_{LZCE}$	$\overline{CE}$ LOW to Low Z <sup>[6]</sup>	3		5		ns
$t_{HZCE}$	$\overline{CE}$ HIGH to High Z <sup>[5, 6]</sup>		8		10	ns
$t_{PU}$	$\overline{CE}$ LOW to Power-Up	0		0		ns
$t_{PD}$	$\overline{CE}$ HIGH to Power-Down		20		25	ns
$t_{DBE}$	Byte Enable to Data Valid		8		10	ns
$t_{LZBE}$	Byte Enable to Low Z	0		0		ns
$t_{HZBE}$	Byte Disable to High Z		8		10	ns
<b>WRITE CYCLE<sup>[7, 8]</sup></b>						
$t_{WC}$	Write Cycle Time	20		25		ns
$t_{SCE}$	$\overline{CE}$ LOW to Write End	13		15		ns
$t_{AW}$	Address Set-Up to Write End	13		15		ns
$t_{HA}$	Address Hold from Write End	0		0		ns
$t_{SA}$	Address Set-Up to Write Start	0		0		ns
$t_{PWE}$	$\overline{WE}$ Pulse Width	13		15		ns
$t_{SD}$	Data Set-Up to Write End	9		10		ns
$t_{HD}$	Data Hold from Write End	0		0		ns
$t_{LZWE}$	$\overline{WE}$ HIGH to Low Z <sup>[6]</sup>	3		5		ns
$t_{HZWE}$	$\overline{WE}$ LOW to High Z <sup>[5, 6]</sup>		8		10	ns
$t_{BW}$	Byte Enable to End of Write	13		15		ns

**Data Retention Characteristics** Over the Operating Range (For L version only)

Parameter	Description	Conditions <sup>[10]</sup>	Min.	Max.	Unit
$V_{DR}$	$V_{CC}$ for Data Retention		2.0		V
$I_{CCDR}$	Data Retention Current	$V_{CC} = V_{DR} = 2.0V$ , $CE \geq V_{CC} - 0.3V$ , $V_{IN} \geq V_{CC} - 0.3V$ or $V_{IN} \leq 0.3V$		330	$\mu A$
$t_{CDR}^{[3]}$	Chip Deselect to Data Retention Time		0		ns
$t_R^{[9]}$	Operation Recovery Time		$t_{RC}$		ns

**Notes:**

9.  $t_r \leq 3$  ns for the -12 and -15 speeds.  $t_r \leq 5$  ns for the -20 and slower speeds.  
 10. No input may exceed  $V_{CC} + 0.5V$ .

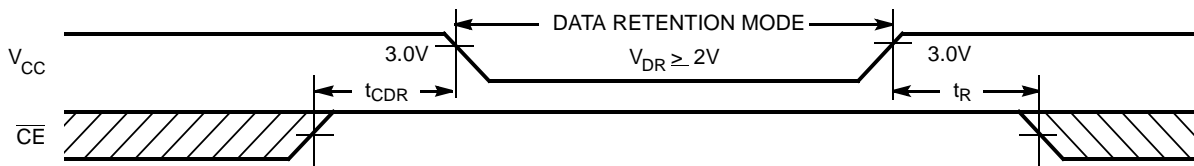
**Data Retention Waveform**

1041BV33-

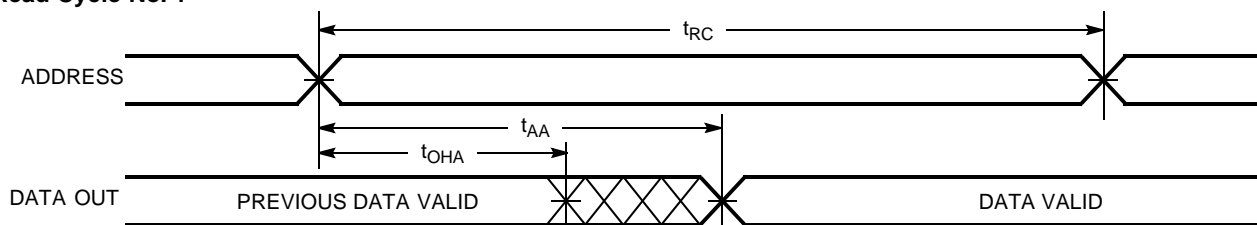
**Switching Waveforms**
**Read Cycle No. 1** <sup>[11, 12]</sup>

1041BV33-6

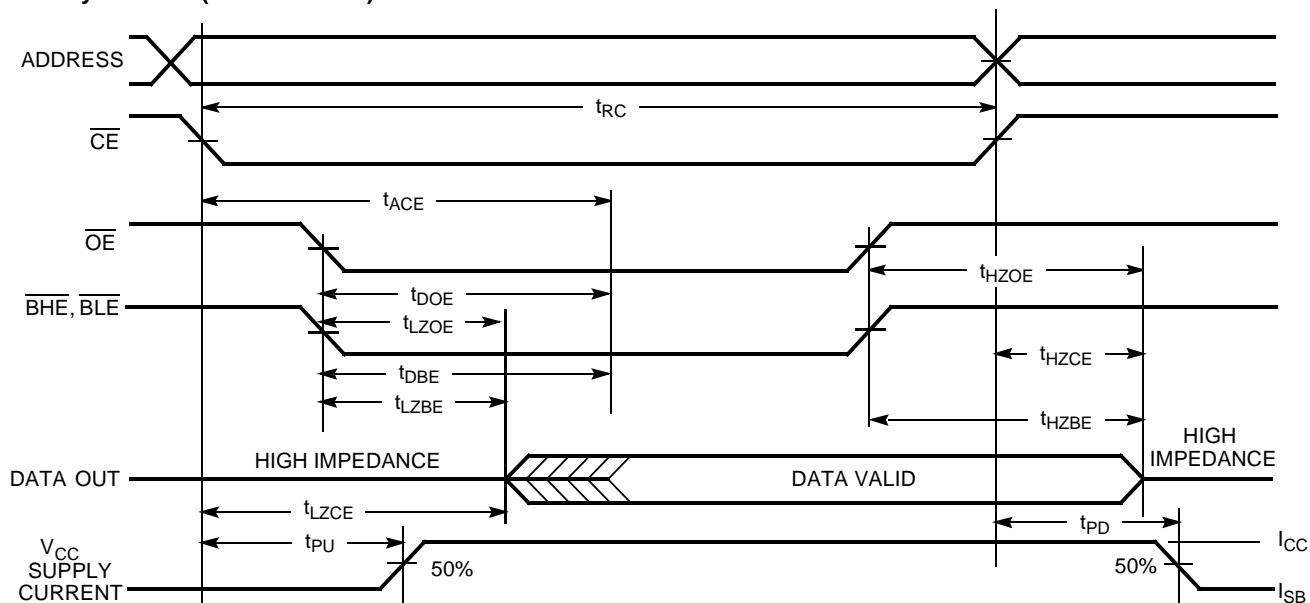
**Read Cycle No. 2 ( $\overline{OE}$  Controlled)** <sup>[12, 13]</sup>

1041BV33-7

**Notes:**

11. Device is continuously selected.  $\overline{OE}$ ,  $\overline{CE}$ ,  $\overline{BHE}$  and/or  $\overline{BLE}$  =  $V_{IL}$ .
12.  $\overline{WE}$  is HIGH for read cycle.
13. Address valid prior to or coincident with  $\overline{CE}$  transition LOW.

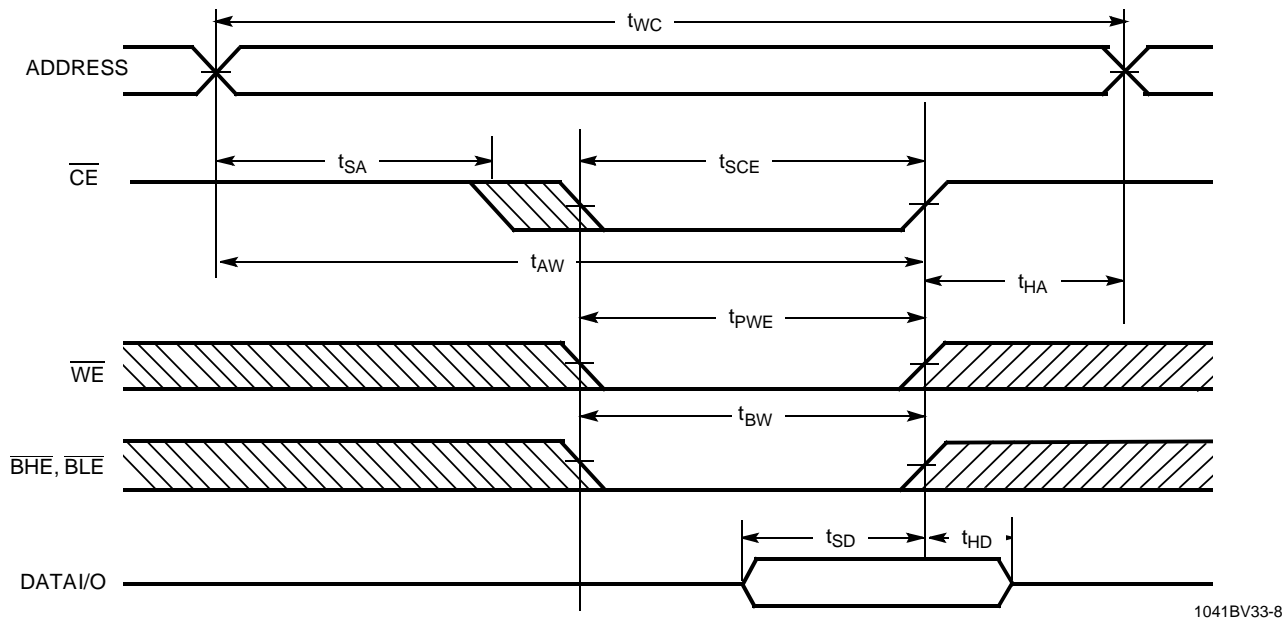
**Switching Waveforms (continued)**
**Write Cycle No. 1 ( $\overline{\text{CE}}$  Controlled)** <sup>[14, 15]</sup>

1041BV33-8

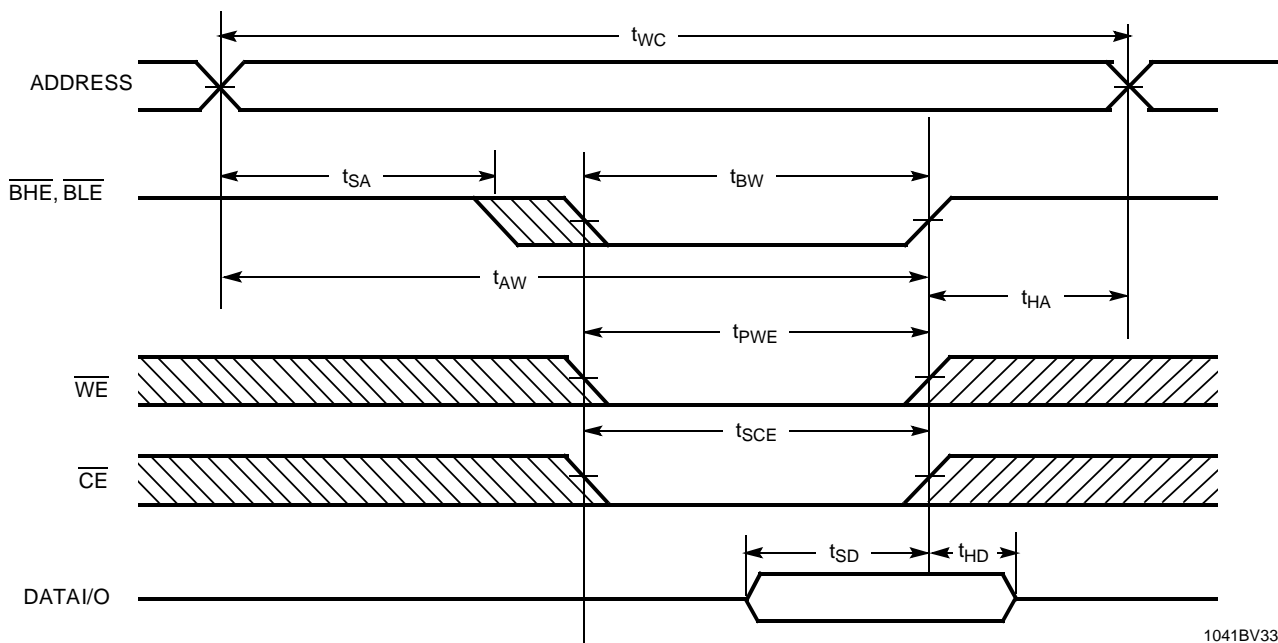
**Write Cycle No. 2 ( $\overline{\text{BLE}}$  or  $\overline{\text{BHE}}$  Controlled)**

1041BV33-9

**Notes:**

14. Data I/O is high-impedance if  $\overline{\text{OE}}$  or  $\overline{\text{BHE}}$  and/or  $\overline{\text{BLE}} = V_{IH}$ .
15. If  $\overline{\text{CE}}$  goes HIGH simultaneously with  $\overline{\text{WE}}$  going HIGH, the output remains in a high-impedance state.

**Switching Waveforms** (continued)

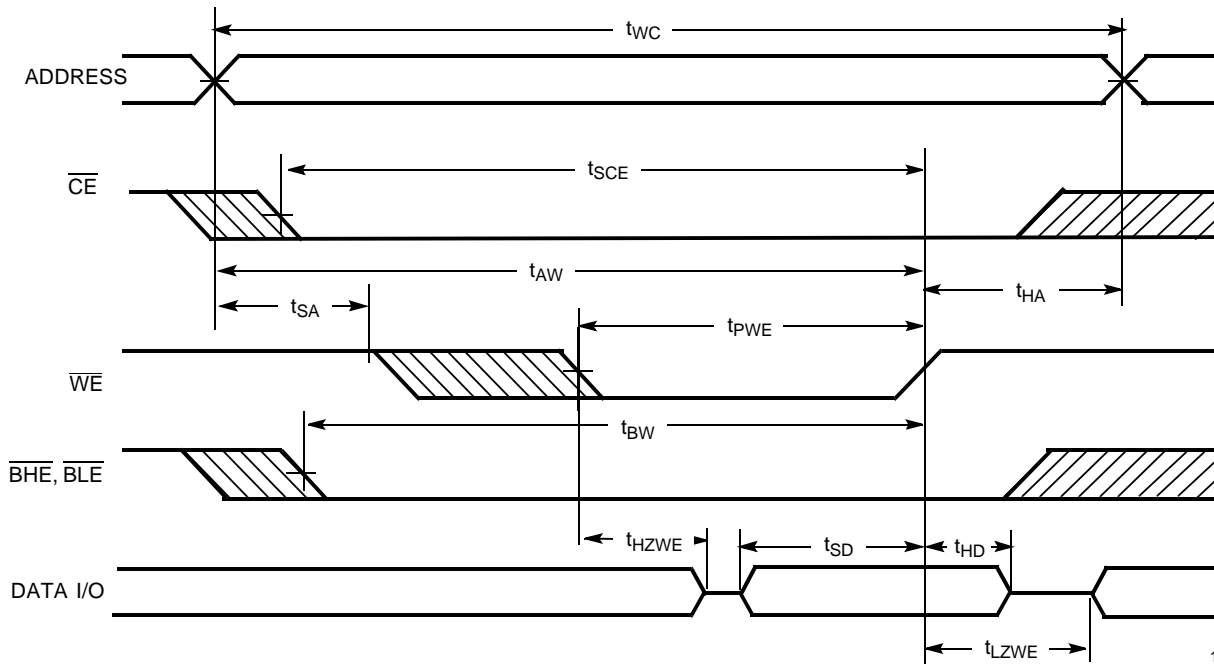
**Write Cycle No.3 ( $\overline{WE}$  Controlled,  $\overline{OE}$  LOW)**

1041BV33-10

**Truth Table**

CE	OE	WE	BLE	BHE	I/O <sub>0</sub> -I/O <sub>7</sub>	I/O <sub>8</sub> -I/O <sub>15</sub>	Mode	Power
H	X	X	X	X	High Z	High Z	Power Down	Standby ( $I_{SB}$ )
L	L	H	L	L	Data Out	Data Out	Read All Bits	Active ( $I_{CC}$ )
L	L	H	L	H	Data Out	High Z	Read Lower Bits Only	Active ( $I_{CC}$ )
L	L	H	H	L	High Z	Data Out	Read Upper Bits Only	Active ( $I_{CC}$ )
L	X	L	L	L	Data In	Data In	Write All Bits	Active ( $I_{CC}$ )
L	X	L	L	H	Data In	High Z	Write Lower Bits Only	Active ( $I_{CC}$ )
L	X	L	H	L	High Z	Data In	Write Upper Bits Only	Active ( $I_{CC}$ )
L	H	H	X	X	High Z	High Z	Selected, Outputs Disabled	Active ( $I_{CC}$ )



**Ordering Information**

Speed (ns)	Ordering Code	Package Name	Package Type	Operating Range
12	CY7C1041BV33-12VC	V34	44-Lead (400-Mil) Molded SOJ	Commercial
	CY7C1041BV33L-12VC	V34	44-Lead (400-Mil) Molded SOJ	
	CY7C1041BV33-12ZC	Z44	44-Pin TSOP II Z44	
	CY7C1041BV33L-12ZC	Z44	44-Pin TSOP II Z44	
15	CY7C1041BV33-15VC	V34	44-Lead (400-Mil) Molded SOJ	Commercial
	CY7C1041BV33L-15VC	V34	44-Lead (400-Mil) Molded SOJ	
	CY7C1041BV33-15ZC	Z44	44-Pin TSOP II Z44	
	CY7C1041BV33L-15ZC	Z44	44-Pin TSOP II Z44	
	CY7C1041BV33-15VI	V34	44-Lead (400-Mil) Molded SOJ	Industrial
	CY7C1041BV33-15ZI	Z44	44-Pin TSOP II Z44	
17	CY7C1041BV33-17VC	V34	44-Lead (400-Mil) Molded SOJ	Commercial
	CY7C1041BV33L-17VC	V34	44-Lead (400-Mil) Molded SOJ	
	CY7C1041BV33-17ZC	Z44	44-Pin TSOP II Z44	
	CY7C1041BV33L-17ZC	Z44	44-Pin TSOP II Z44	
	CY7C1041BV33-17VI	V34	44-Lead (400-Mil) Molded SOJ	Industrial
	CY7C1041BV33-17ZI	Z44	44-Pin TSOP II Z44	
20	CY7C1041BV33-20VC	V34	44-Lead (400-Mil) Molded SOJ	Commercial
	CY7C1041BV33L-20VC	V34	44-Lead (400-Mil) Molded SOJ	
	CY7C1041BV33-20ZC	Z44	44-Pin TSOP II Z44	
	CY7C1041BV33L-20ZC	Z44	44-Pin TSOP II Z44	
	CY7C1041BV33-20VI	V34	44-Lead (400-Mil) Molded SOJ	Industrial
	CY7C1041BV33-20ZI	Z44	44-Pin TSOP II Z44	
25	CY7C1041BV33-25VC	V34	44-Lead (400-Mil) Molded SOJ	Commercial
	CY7C1041BV33L-25VC	V34	44-Lead (400-Mil) Molded SOJ	
	CY7C1041BV33-25ZC	Z44	44-Pin TSOP II Z44	
	CY7C1041BV33L-25ZC	Z44	44-Pin TSOP II Z44	
	CY7C1041BV33-25VI	V34	44-Lead (400-Mil) Molded SOJ	Industrial
	CY7C1041BV33-25ZI	Z44	44-Pin TSOP II Z44	

Package Diagrams

44-Lead (400-Mil) Molded SOJ V34

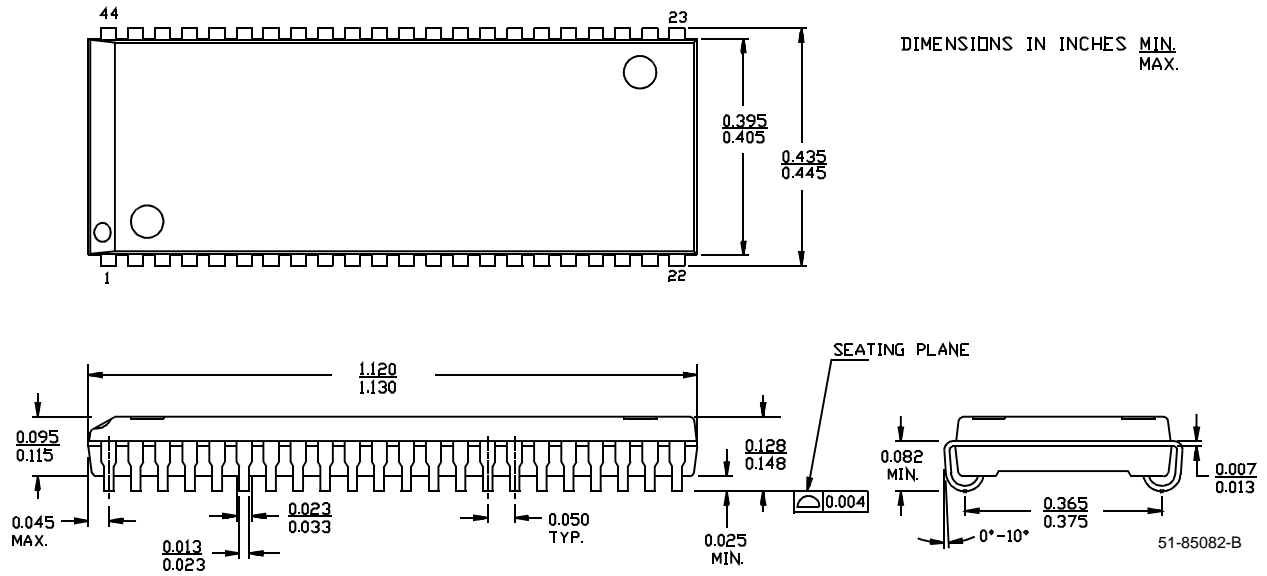

44-Pin TSOP II Z44

DIMENSION IN MM (INCH)  
MAX  
MIN.

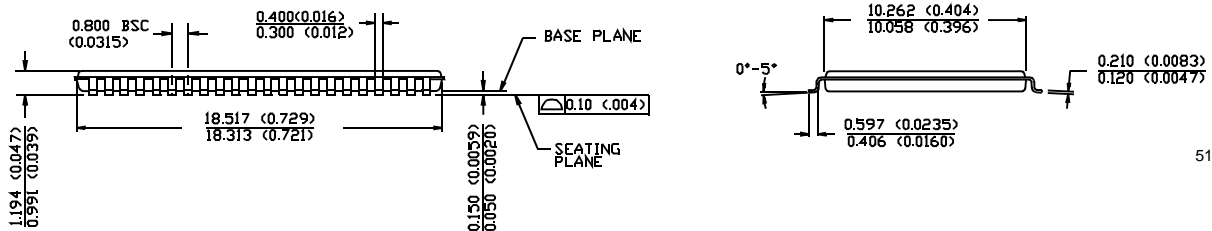
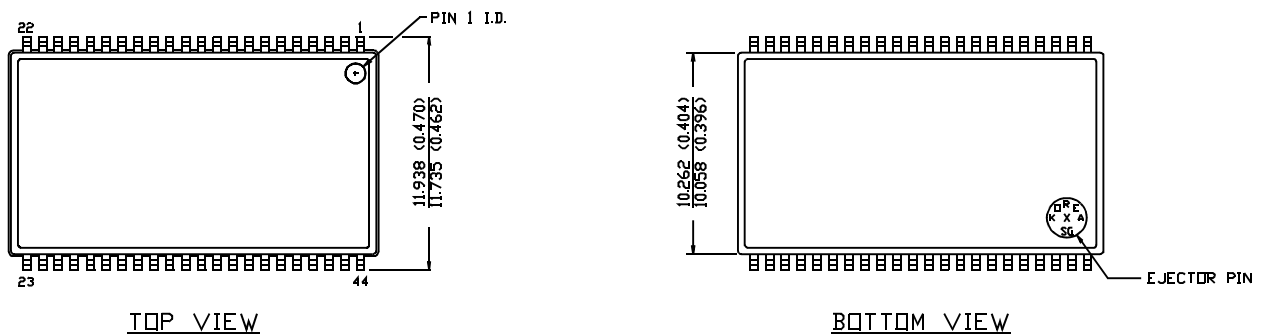



**CY7C1041BV33**

<b>Document Title: CY7C1041BV33 256K x 16 SRAM</b> <b>Document Number: 38-05168</b>				
<b>REV.</b>	<b>ECN NO.</b>	<b>Issue Date</b>	<b>Orig. of Change</b>	<b>Description of Change</b>
**	111840	11/17/01	DSG	Change from Spec number: 38-00932 to 38-05168