

LTC2901

ABSOLUTE MAXIMUM RATINGS

(Notes 1, 2, 3)

V1, V2, V3, V4, V _{PG}	-0.3V to 7V
RST (LTC2901-1)	-0.3V to 7V
RST (LTC2901-2)	-0.3V to (V2 + 0.3V)
COMPX	-0.3V to 7V
CWT, WDO	-0.3V to 7V
V _{REF} , CRT, WDI	-0.3V to (V _{CC} + 0.3V)
Reference Load Current (I _{VREF})	±1mA
V4 Input Current (-ADJ Mode)	-1mA
Operating Temperature Range	
LTC2901-1C/LTC2901-2C	0°C to 70°C
LTC2901-1I/LTC2901-2I	-40°C to 85°C
Storage Temperature Range	-65°C to 150°C
Lead Temperature (Soldering, 10 sec)	300°C

PACKAGE/ORDER INFORMATION

<p>GN PACKAGE 16-LEAD PLASTIC SSOP T_{JMAX} = 125°C, θ_{JA} = 130°C/W</p>	ORDER PART NUMBER
	LTC2901-1CGN LTC2901-2CGN LTC2901-1IGN LTC2901-2IGN
	GN16 PART MARKING
	29011 29012 29011I 29012I

Consult LTC Marketing for parts specified with wider operating temperature ranges.

ELECTRICAL CHARACTERISTICS

The ● denotes the specifications which apply over the full operating temperature range, otherwise specifications are at T_A = 25°C. V_{CC} = 5V, unless otherwise noted. (Note 3)

SYMBOL	PARAMETER	CONDITIONS	MIN	TYP	MAX	UNITS
V _{RT50}	5V, 5% Reset Threshold	V1 Input Threshold	● 4.600	4.675	4.750	V
V _{RT33}	3.3V, 5% Reset Threshold	V1, V2 Input Threshold	● 3.036	3.086	3.135	V
V _{RT30}	3V, 5% Reset Threshold	V2 Input Threshold	● 2.760	2.805	2.850	V
V _{RT25}	2.5V, 5% Reset Threshold	V2, V3 Input Threshold	● 2.300	2.338	2.375	V
V _{RT18}	1.8V, 5% Reset Threshold	V3, V4 Input Threshold	● 1.656	1.683	1.710	V
V _{RT15}	1.5V, 5% Reset Threshold	V3, V4 Input Threshold	● 1.380	1.403	1.425	V
V _{RTA}	ADJ Reset Threshold	V3, V4 Input Threshold	● 0.492	0.500	0.508	V
V _{RTAN}	-ADJ Reset Threshold	V4 Input Threshold	● -18	0	18	mV
V _{CC}	Minimum Internal Operating Voltage	RST, COMPX in Correct Logic State; V _{CC} Rising Prior to Program	●		1	V
V _{CCMINP}	Minimum Required for Programming	V _{CC} Rising	●		2.42	V
V _{CCMINC}	Minimum Required for Comparators	V _{CC} Falling	●		2.32	V
V _{REF}	Reference Voltage	V _{CC} ≥ 2.3V, I _{VREF} = ±1mA, C _{REF} ≤ 1000pF	● 1.192	1.210	1.228	V
V _{PG}	Programming Voltage Range	V _{CC} ≥ V _{CCMINP}	● 0		V _{REF}	V
I _{VPG}	V _{PG} Input Current	V _{PG} = V _{REF}	●		±20	nA
I _{V1}	V1 Input Current	V1 = 5V, I _{VREF} = 12μA, (Note 4)	●	43	75	μA
I _{V2}	V2 Input Current	V2 = 3.3V	●	0.8	2	μA
I _{V3}	V3 Input Current	V3 = 2.5V	●	0.52	1.2	μA
		V3 = 0.55V (ADJ Mode)	● -15		15	nA
I _{V4}	V4 Input Current	V4 = 1.8V	●	0.34	0.8	μA
		V4 = 0.55V (ADJ Mode)	● -15		15	nA
		V4 = -0.05V (-ADJ Mode)	● -15		15	nA
I _{CRT(UP)}	CRT Pull-Up Current	V _{CRT} = 0V	● -1.4	-2	-2.6	μA
I _{CRT(DN)}	CRT Pull-Down Current	V _{CRT} = 1.3V	● 10	20	30	μA
t _{RST}	Reset Time-Out Period	C _{RT} = 1500pF	● 4.9	6.9	8.9	ms

ELECTRICAL CHARACTERISTICS

The ● denotes the specifications which apply over the full operating temperature range, otherwise specifications are at $T_A = 25^\circ\text{C}$. $V_{CC} = 5\text{V}$, unless otherwise noted. (Note 3)

SYMBOL	PARAMETER	CONDITIONS	MIN	TYP	MAX	UNITS	
t_{UV}	V_X Undervoltage Detect to $\overline{\text{RST}}$ or COMPX	V_X Less Than Reset Threshold V_{RTX} by More Than 1%		150		μs	
V_{OL}	Output Voltage Low $\overline{\text{RST}}$, COMPX	$I_{\text{SINK}} = 2.5\text{mA}$; $V_1 = 3\text{V}$, $V_2 = 3\text{V}$; $V_3, V_4 = 0\text{V}$; $V_{\text{PG}} = 0\text{V}$	●	0.15	0.4	V	
		$I_{\text{SINK}} = 100\mu\text{A}$; $V_2 = 1\text{V}$; $V_1, V_3, V_4 = 0\text{V}$	●	0.05	0.3	V	
		$I_{\text{SINK}} = 100\mu\text{A}$; $V_1 = 1\text{V}$; $V_2, V_3, V_4 = 0\text{V}$	●	0.05	0.3	V	
V_{OH}	Output Voltage High $\overline{\text{RST}}$, $\overline{\text{WDO}}$, COMPX (Note 5)	$I_{\text{SOURCE}} = 1\mu\text{A}$	●	$V_2 - 1$		V	
V_{OL}	Output Voltage Low $\overline{\text{WDO}}$	$I_{\text{SINK}} = 2.5\text{mA}$; $V_1 = 5\text{V}$, $V_2 = 3.3\text{V}$; $V_3, V_4 = 1\text{V}$; $V_{\text{PG}} = 0\text{V}$	●	0.15	0.4	V	
V_{OH}	Output Voltage High $\overline{\text{RST}}$ (LTC2901-2) (Note 6)	$I_{\text{SOURCE}} = 200\mu\text{A}$	●	$0.8 \cdot V_2$		V	
$I_{\text{CWT(UP)}}$	CWT Pull-Up Current	$V_{\text{CWT}} = 0\text{V}$	●	-1.4	-2	-2.6	μA
$I_{\text{CWT(DN)}}$	CWT Pull-Down Current	$V_{\text{CWT}} = 1.3\text{V}$	●	10	20	30	μA
t_{WD}	Watchdog Time-Out Period	$C_{\text{WT}} = 1500\text{pF}$	●	20	30	40	ms
V_{IH}	WDI Input Threshold High	$V_{\text{CC}} = 3.3\text{V}$ to 5.5V	●		1.6	V	
V_{IL}	WDI Input Threshold Low	$V_{\text{CC}} = 3.3\text{V}$ to 5.5V	●	0.4		V	
t_{WP}	WDI Input Pulse Width	$V_{\text{CC}} = 3.3\text{V}$	●	150		ns	
I_{WDI}	WDI Pull-Up Current	$V_{\text{WDI}} = 0\text{V}$		-10		μA	

Note 1: Absolute Maximum Ratings are those values beyond which the life of a device may be impaired.

Note 2: All voltage values are with respect to GND.

Note 3: The greater of V_1 , V_2 is the internal supply voltage (V_{CC}).

Note 4: Under static no-fault conditions, V_1 will necessarily supply quiescent current. If at any time V_2 is larger than V_1 , V_2 must be capable of supplying the quiescent current, programming (transient) current and reference load current.

Note 5: The output pins $\overline{\text{RST}}$, $\overline{\text{WDO}}$ and COMPX have internal pull-ups to V_2 of typically $6\mu\text{A}$. However, external pull-up resistors may be used when faster rise times are required or for V_{OH} voltages greater than V_2 .

Note 6: The push-pull $\overline{\text{RST}}$ output pin on the LTC2901-2 is *actively* pulled up to V_2 .

LTC2901

TEST CIRCUITS

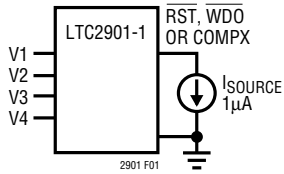

Figure 1. $\overline{\text{RST}}$, $\overline{\text{WDO}}$, $\overline{\text{COMPX}}$ V_{OH} Test

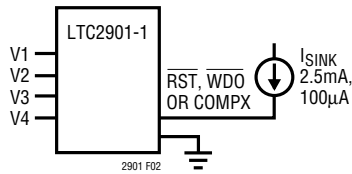

Figure 2. $\overline{\text{RST}}$, $\overline{\text{WDO}}$, $\overline{\text{COMPX}}$ V_{OL} Test

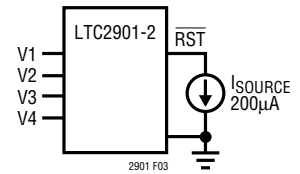
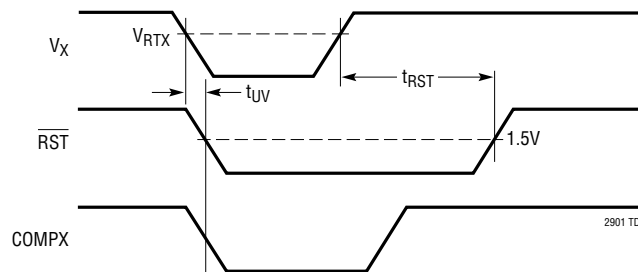

Figure 3. Active Pull-Up $\overline{\text{RST}}$ V_{OH} Test

TIMING DIAGRAMS

V_x Monitor Timing



Watchdog Timing

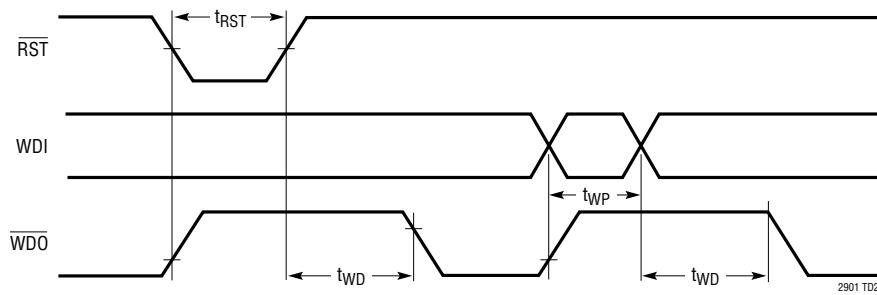

TYPICAL PERFORMANCE CHARACTERISTICS

5V Threshold Voltage vs Temperature

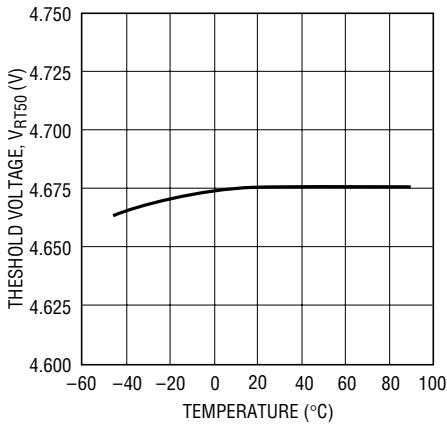

2901 G01

3.3V Threshold Voltage vs Temperature

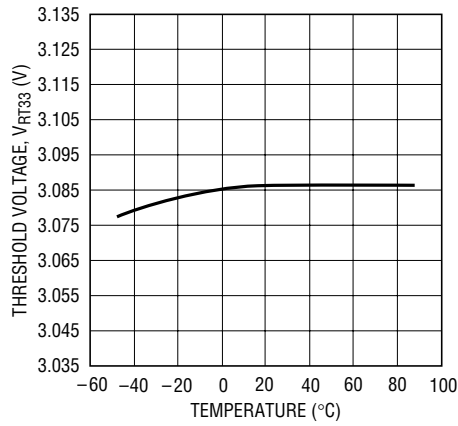

2901 G02

3V Threshold Voltage vs Temperature

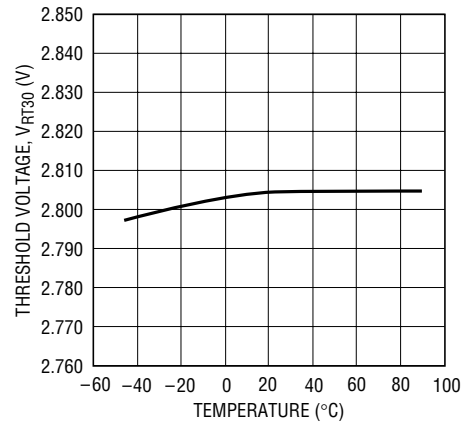

2901 G03

2.5V Threshold Voltage vs Temperature

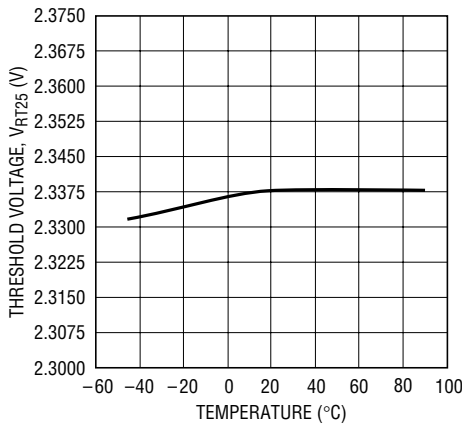

2901 G04

1.8V Threshold Voltage vs Temperature

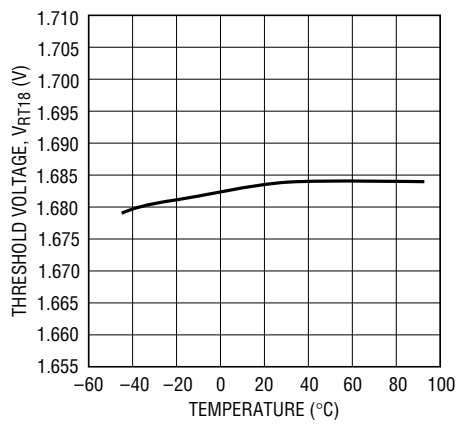

2901 G05

1.5V Threshold Voltage vs Temperature

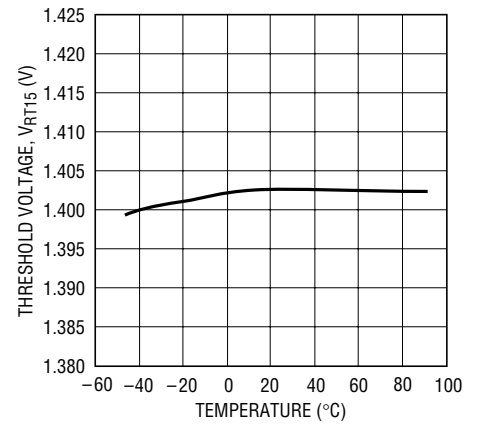

2901 G06

ADJ Threshold Voltage vs Temperature

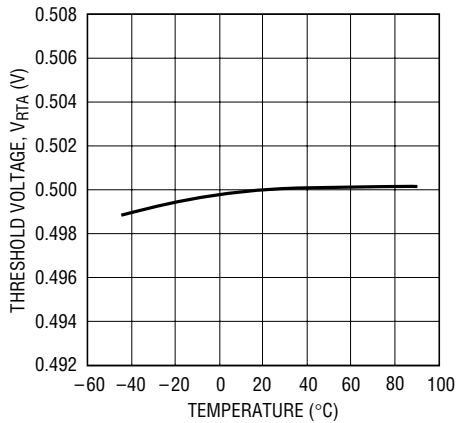

2901 G07

-ADJ Threshold Voltage vs Temperature

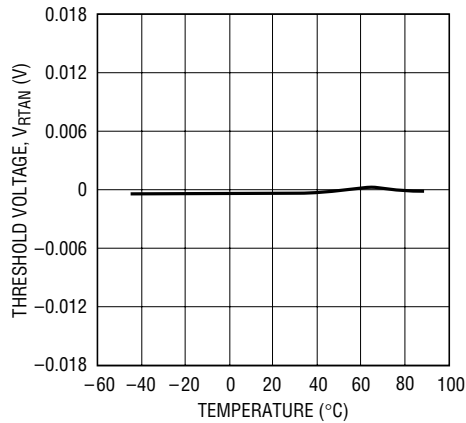

2901 G08

V_{REF} vs Temperature

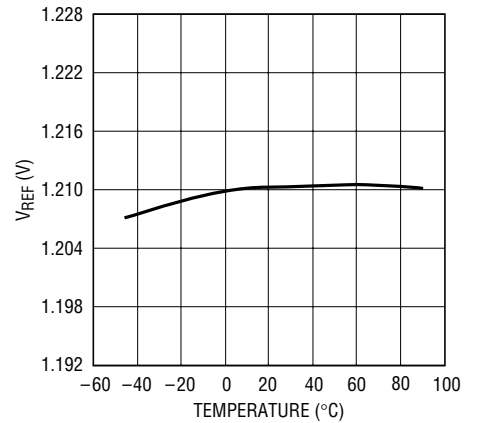

2901 G23

TYPICAL PERFORMANCE CHARACTERISTICS

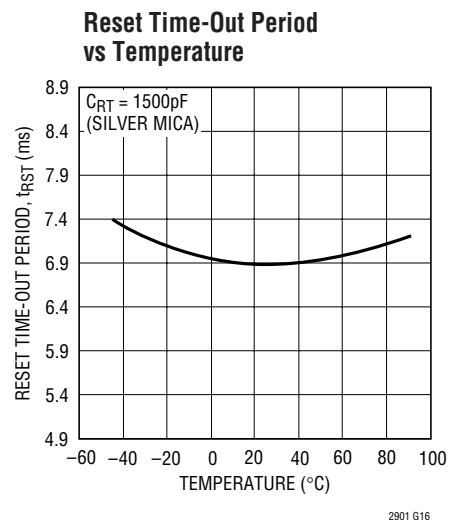
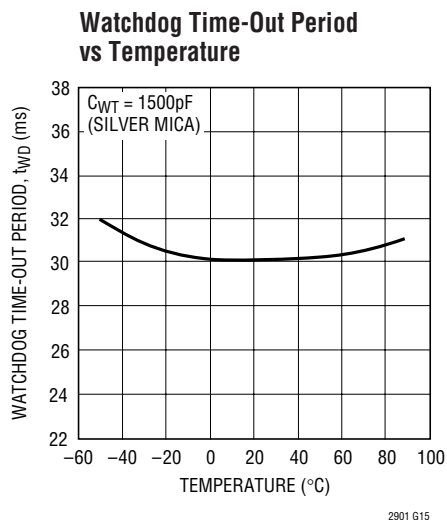
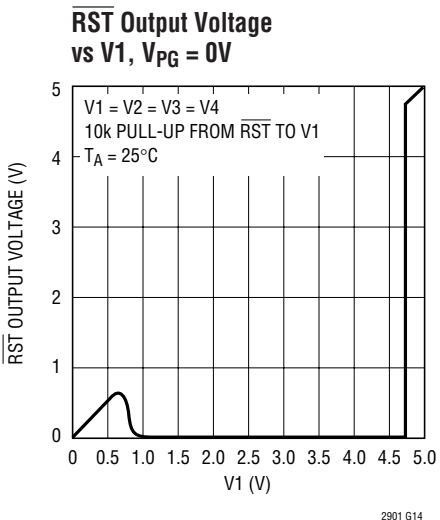
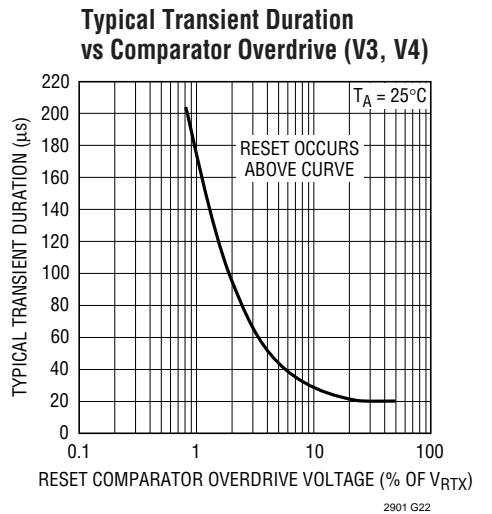
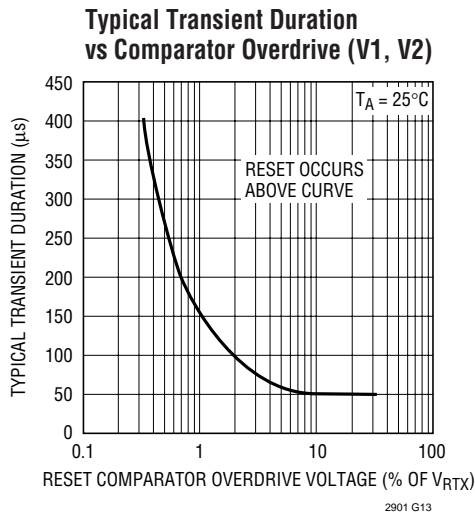
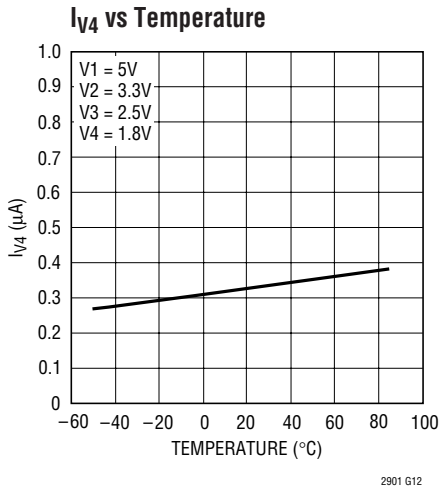
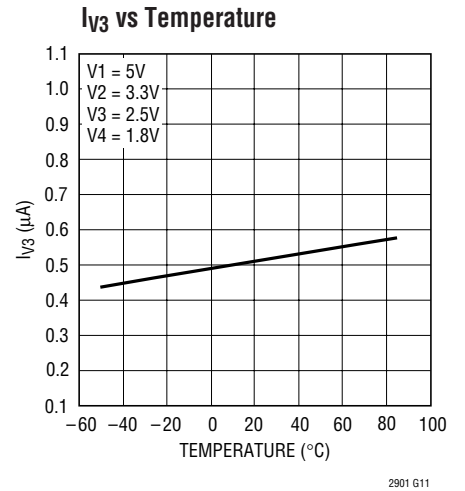
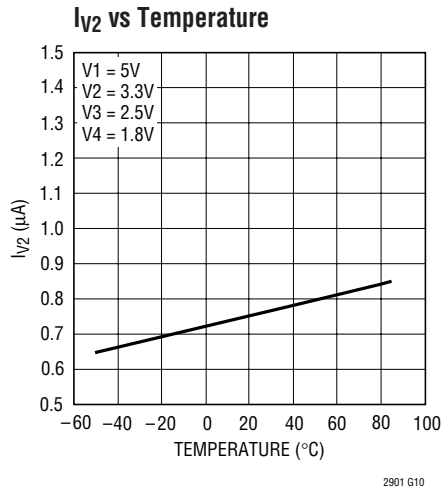
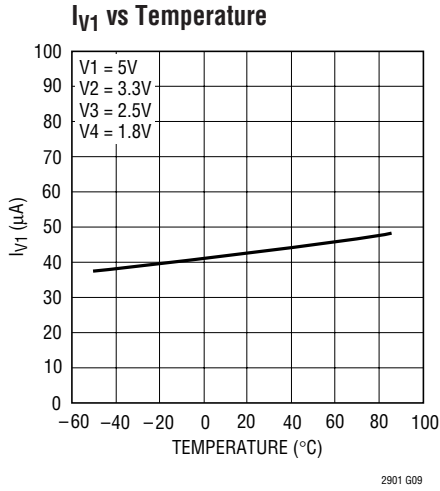

TYPICAL PERFORMANCE CHARACTERISTICS

Watchdog Time-Out Period vs Capacitance

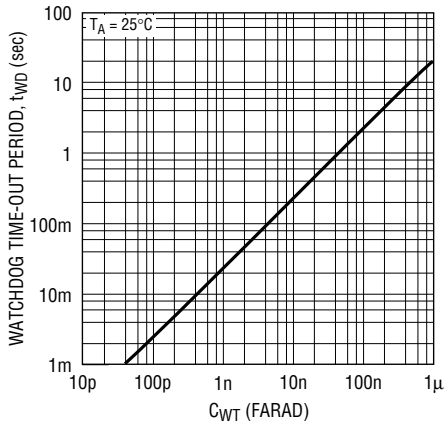

2901 G17

Reset Time-Out Period vs Capacitance

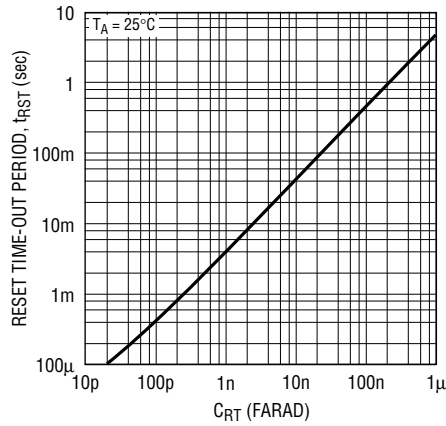

2901 G18

RST, WDO, COMPX I_{SINK} vs Supply Voltage

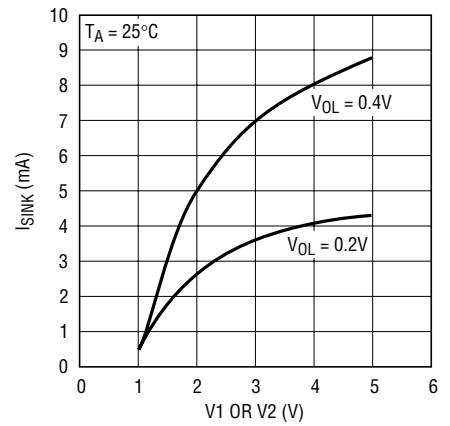

2901 G19

RST, WDO, COMPX Voltage Output Low vs Output Sink Current

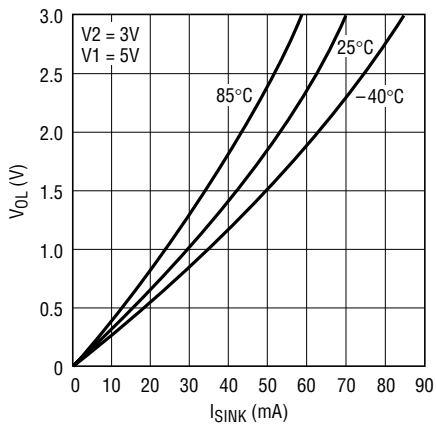

2901 G20

RST High Level Output Voltage vs Output Source Current (LTC2901-2)

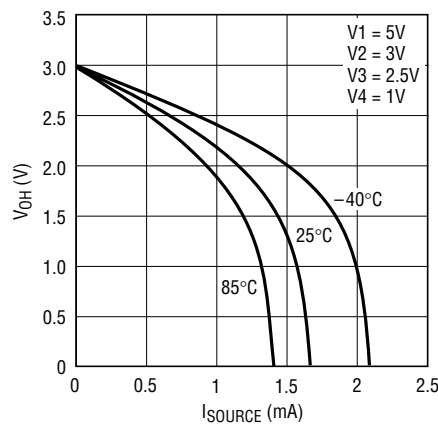

2901 G21

COMPX and WDO Pull-Up Current vs V2 (COMPX and WDO Held at 0V)

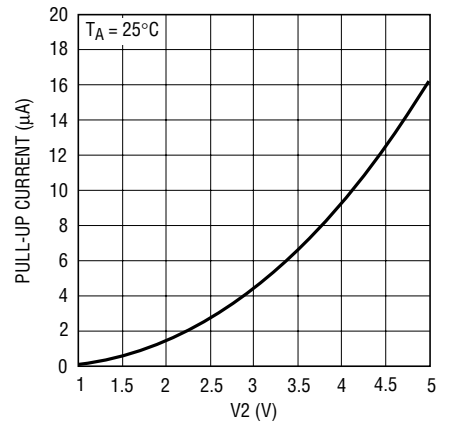

2901 G24

COMPX Propagation Delay vs Input Overdrive Above Threshold

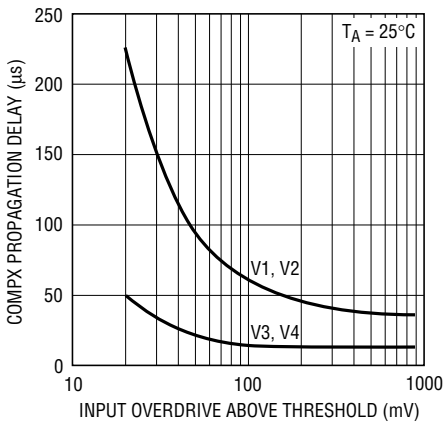

2901 G25

RST Pull-Up Current vs V2 (LTC2901-1)

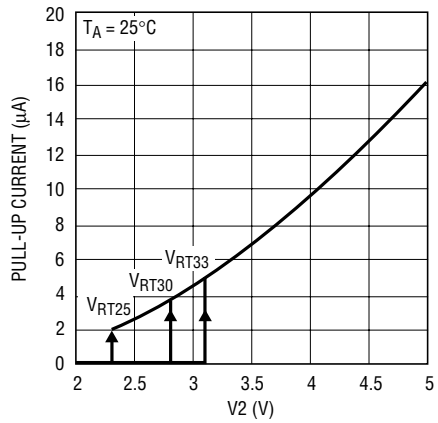

2901 G26

RST Pull-Up Current vs V2 (LTC2901-2)

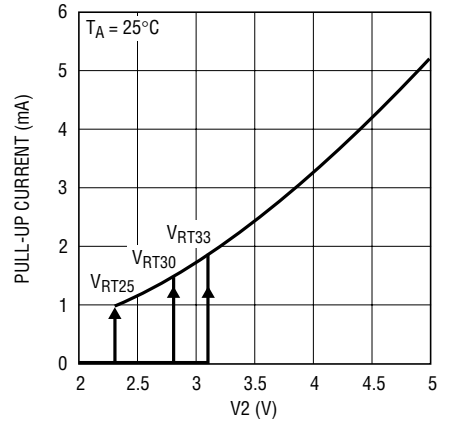

2901 G27

PIN FUNCTIONS

COMP3 (Pin 1): Comparator Output 3. Nondelayed, active high logic output with weak pull-up to V2. Pulls high when V3 is above reset threshold. May be pulled greater than V2 using external pull-up.

COMP1 (Pin 2): Comparator Output 1. Nondelayed, active high logic output with weak pull-up to V2. Pulls high when V1 is above reset threshold. May be pulled greater than V2 using external pull-up.

V3 (Pin 3): Voltage Input 3. Select from 2.5V, 1.8V, 1.5V or ADJ. See Table 1 for details.

V1 (Pin 4): Voltage Input 1. Select from 5V or 3.3V. See Table 1 for details. The greater of (V1, V2) is also V_{CC} for the chip. Bypass this pin to ground with a 0.1 μ F (or greater) capacitor.

CRT (Pin 5): Reset Delay Time Programming Pin. Attach an external capacitor (C_{RT}) to GND to set a reset delay time of 4.6ms/nF. Leaving the pin open generates a minimum delay of approximately 50 μ s. A 47nF capacitor will generate a 216ms reset delay time.

RST (Pin 6): Reset Logic Output. Active low with weak pull-up to V2 (LTC2901-1) or active pull-up to V2 (LTC2901-2). Pulls low when any voltage input is below the reset threshold and held low for programmed delay time after all voltage inputs are above threshold. May be pulled above V2 using an external pull-up (LTC2901-1 only).

WDO (Pin 7): Watchdog Output. Active low logic output with weak pull-up to V2. May be pulled greater than V2 using external pull-up. The watchdog output pulls low if the watchdog timer is allowed to time out and remains low until set high by the next WDI transition or anytime \overline{RST} is low. The watchdog timer is enabled when \overline{RST} is high.

WDI (Pin 8): Watchdog Input. A logic input whose rising or falling edge must occur on this pin (while \overline{RST} is high) within the selected watchdog time-out period, prohibiting a high-to-low transition on the WDO pin. The watchdog time-out period is set by the value of the capacitor that is attached to the CWT pin. A rising or falling edge on the WDI pin clears the voltage on the C_{WT} capacitor, preventing \overline{WDO} from going low. When disabling the watchdog function, tie CWT to GND.

CWT (Pin 9): Watchdog Time-Out Programming Pin. Attach a capacitor (C_{WT}) between CWT and GND to set a watchdog time-out period of 20ms/nF. Leaving the pin open generates a minimum time-out of approximately 200 μ s. A 47nF capacitor will generate a 940ms watchdog time-out period.

GND (Pin 10): Ground.

V_{PG} (Pin 11): Voltage Threshold Combination Select Input. Connect to an external 1% resistive divider between V_{REF} and GND to select 1 of 16 combinations of preset and/or \pm adjustable voltage thresholds (see Table 1). Do not add capacitance on the V_{PG} pin.

V_{REF} (Pin 12): Buffered Reference Voltage. A 1.210V nominal reference used for programming voltage (V_{PG}) and for the offset of negative adjustable applications. The buffered reference can source and sink up to 1mA. The reference can drive a bypass capacitor of up to 1000pF without oscillation.

V4 (Pin 13): Voltage Input 4. Select from 1.8V, 1.5V, ADJ or $-\text{ADJ}$. See Table 1 for details.

V2 (Pin 14): Voltage Input 2. Select from 3.3V, 3V or 2.5V. See Table 1 for details. The greater of (V1, V2) is also V_{CC} for chip. Bypass this pin to ground with a 0.1 μ F (or greater) capacitor. All logic outputs (COMP1, COMP2, COMP3, COMP4, \overline{RST} , \overline{WDO}) are weakly pulled up to V2 (LTC2901-1). \overline{RST} is actively pulled up to V2 in the LTC2901-2.

COMP4 (Pin 15): Comparator Output 4. Nondelayed, active high logic output with weak pull-up to V2. Pulls high when V4 is above reset threshold. May be pulled greater than V2 using external pull-up.

COMP2 (Pin 16): Comparator Output 2. Nondelayed, active high logic output with weak pull-up to V2. Pulls high when V2 is above reset threshold. May be pulled greater than V2 using external pull-up.

BLOCK DIAGRAM

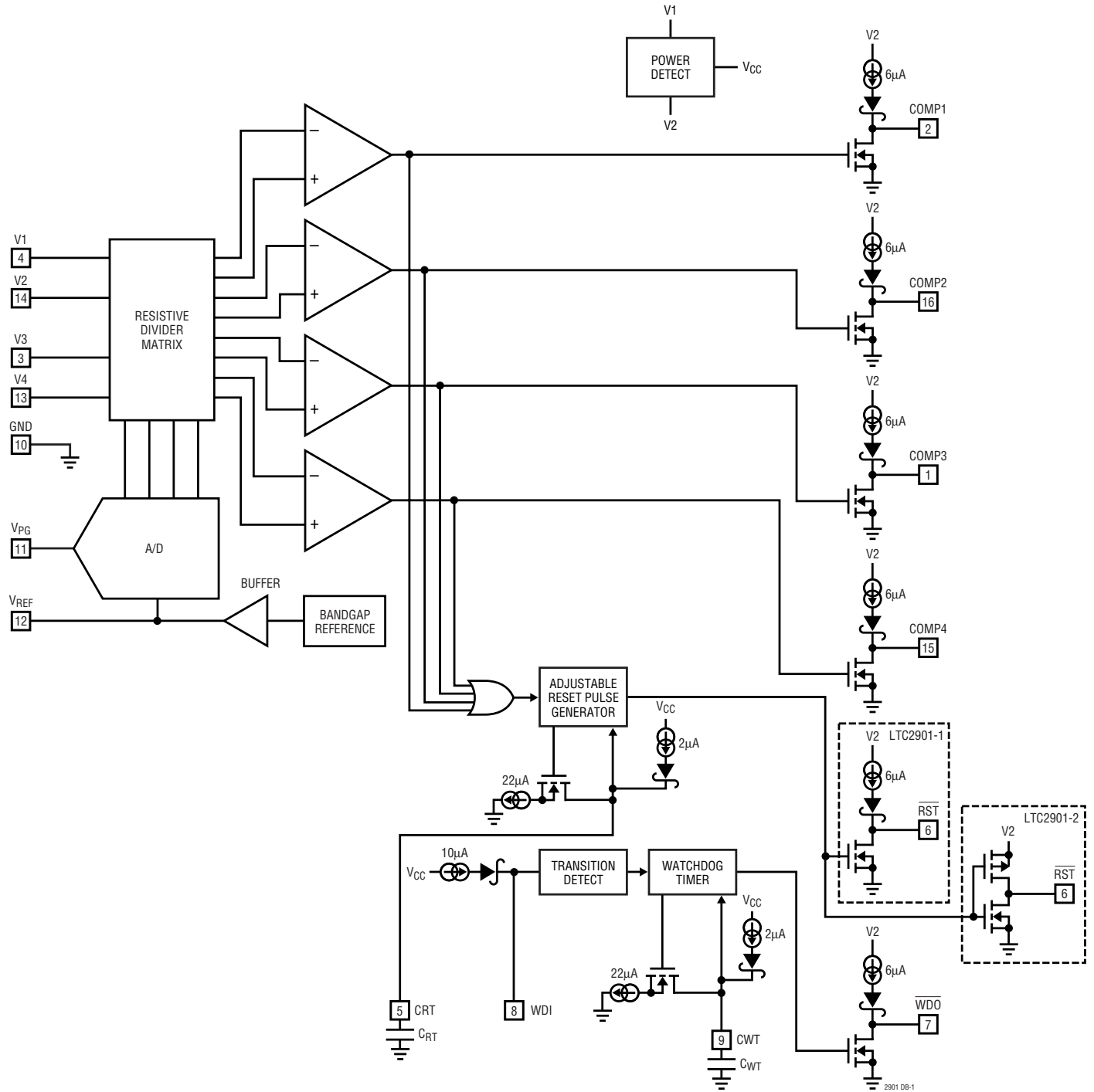

APPLICATIONS INFORMATION

Power-Up

The greater of V1, V2 is the internal supply voltage (V_{CC}). On power-up, V_{CC} will power the drive circuits for the \overline{RST} and the COMPX pins. This ensures that the \overline{RST} and COMPX outputs will be low as soon as V1 or V2 reaches 1V. The \overline{RST} and COMPX outputs will remain low until the part is programmed. After programming, if any one of the V_X inputs is below its programmed threshold, \overline{RST} will be a logic low. Once all the V_X inputs rise above their thresholds, an internal timer is started and \overline{RST} is released after the programmed delay time. If $V_{CC} < (V3 - 1)$ and $V_{CC} < 2.4V$, the V3 input impedance will be low ($1k\Omega$ typ).

Monitor Programming

The LTC2901 input voltage combination is selected by placing the recommended resistive divider from V_{REF} to GND and connecting the tap point to V_{PG} , as shown in Figure 4. Table 1 offers recommended 1% resistor values for the various modes. The last column in Table 1 specifies optimum V_{PG}/V_{REF} ratios (± 0.01) to be used when programming with a ratiometric DAC.

During power-up, once V1 or V2 reaches 2.4V max, the monitor enters a programming period of approximately

Table 1. Voltage Threshold Programming

MODE	V1 (V)	V2 (V)	V3 (V)	V4 (V)	R1 (k Ω)	R2 (k Ω)	$\frac{V_{PG}}{V_{REF}}$
0	5.0	3.3	ADJ	ADJ	Open	Short	0.000
1	5.0	3.3	ADJ	-ADJ	93.1	9.53	0.094
2	3.3	2.5	ADJ	ADJ	86.6	16.2	0.156
3	3.3	2.5	ADJ	-ADJ	78.7	22.1	0.219
4	3.3	2.5	1.5	ADJ	71.5	28.0	0.281
5	5.0	3.3	2.5	ADJ	66.5	34.8	0.344
6	5.0	3.3	2.5	1.8	59.0	40.2	0.406
7	5.0	3.3	2.5	1.5	53.6	47.5	0.469
8	5.0	3.0	2.5	ADJ	47.5	53.6	0.531
9	5.0	3.0	ADJ	ADJ	40.2	59.0	0.594
10	3.3	2.5	1.8	1.5	34.8	66.5	0.656
11	3.3	2.5	1.8	ADJ	28.0	71.5	0.719
12	3.3	2.5	1.8	-ADJ	22.1	78.7	0.781
13	5.0	3.3	1.8	-ADJ	16.2	86.6	0.844
14	5.0	3.3	1.8	ADJ	9.53	93.1	0.906
15	5.0	3.0	1.8	ADJ	Short	Open	1.000

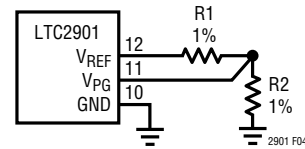

Figure 4. Monitor Programming

150 μ s during which the voltage on the V_{PG} pin is sampled and the monitor is configured to the desired input combination. Do not add capacitance to the V_{PG} pin. Immediately after programming, the comparators are enabled and supply monitoring will begin.

Supply Monitoring

The LTC2901 is a low power, high accuracy programmable quad supply monitoring circuit with four nondelayed monitor outputs, a common reset output and a watchdog timer. Watchdog and reset timing are both adjustable using external capacitors. Single pin programming selects 1 of 16 input voltage monitor combinations. All four voltage inputs must be above predetermined thresholds for the reset not to be invoked. The LTC2901 will assert the reset and comparator outputs during power-up, power-down and brownout conditions on any one of the voltage inputs.

The inverting inputs on the V3 and/or V4 comparators are set to 0.5V when the positive adjustable modes are selected (Figure 5). The tap point on an external resistive divider, connected between the positive voltage being sensed and ground, is connected to the high impedance noninverting inputs (V3, V4). The trip voltage is calculated from:

$$V_{TRIP} = 0.5V \left(1 + \frac{R3}{R4} \right)$$

In the negative adjustable mode, the noninverting input on the V4 comparator is connected to ground (Figure 6). The tap point on an external resistive divider, connected between the negative voltage being sensed and the V_{REF} pin, is connected to the high impedance inverting input (V4). V_{REF} provides the necessary level shift required to operate at ground. The trip voltage is calculated from:

$$V_{TRIP} = -V_{REF} \left(\frac{R3}{R4} \right); V_{REF} = 1.210V \text{ Nominal}$$

APPLICATIONS INFORMATION

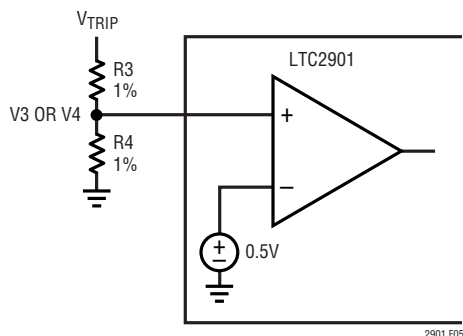

Figure 5. Setting the Positive Adjustable Trip Point

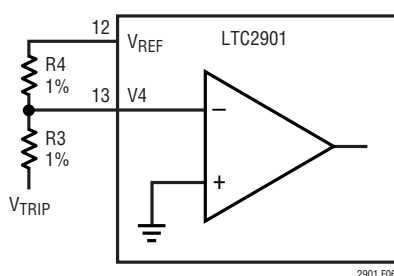

Figure 6. Setting the Negative Adjustable Trip Point

In a negative adjustable application, the minimum value for R4 is limited by the sourcing capability of V_{REF} (±1mA). With no other load on V_{REF}, R4 (minimum) is:

$$1.21\text{V} \div 1\text{mA} = 1.21\text{k}\Omega.$$

Tables 2 and 3 offer suggested 1% resistor values for various adjustable applications.

Although all four supply monitor comparators have built-in glitch immunity, bypass capacitors on V1 and V2 are recommended because the greater of V1 or V2 is also the V_{CC} for the chip. Filter capacitors on the V3 and V4 inputs are allowed.

Power-Down

On power-down, once any of the V_X inputs drop below their threshold, RST and COMPX are held at a logic low. A logic low of 0.4V is guaranteed until both V1 and V2 drop below 1V. If the bandgap reference becomes invalid (V_{CC} < 2V typ), the part will reprogram once V_{CC} rises above 2.4V max.

Table 2. Suggested 1% Resistor Values for the ADJ Inputs

V _{SUPPLY} (V)	V _{TRIP} (V)	R3 (kΩ)	R4 (kΩ)
12	11.25	2150	100
10	9.4	1780	100
8	7.5	1400	100
7.5	7	1300	100
6	5.6	1020	100
5	4.725	845	100
3.3	3.055	511	100
3	2.82	464	100
2.5	2.325	365	100
1.8	1.685	237	100
1.5	1.410	182	100
1.2	1.120	124	100
1	0.933	86.6	100
0.9	0.840	68.1	100

Table 3. Suggested 1% Resistor Values for the -ADJ Input

V _{SUPPLY} (V)	V _{TRIP} (V)	R3 (kΩ)	R4 (kΩ)
-2	-1.87	187	121
-5	-4.64	464	121
-5.2	-4.87	487	121
-10	-9.31	931	121
-12	-11.30	1130	121

Monitor Output Rise and Fall Time Estimation

All of the outputs (RST, COMPX, WDO) have strong pull-down capability. If the external load capacitance (C_{LOAD}) for a particular output is known, output fall time (10% to 90%) is estimated using:

$$t_{\text{FALL}} \approx 2.2 \cdot R_{\text{PD}} \cdot C_{\text{LOAD}}$$

where R_{PD} is the on-resistance of the internal pull-down transistor. The typical performance curve (V_{OL} vs I_{SINK}) demonstrates that the pull-down current is somewhat linear versus output voltage. Using the 25°C curve, R_{PD} is estimated to be approximately 40Ω. Assuming a 150pF load capacitance, the fall time is about 13.2ns.

Although the outputs are considered to be “open-drain,” they do have a weak pull-up capability (see COMPX or RST

APPLICATIONS INFORMATION

Pull-Up Current vs V2 curve). Output rise time (10% to 90%) is estimated using:

$$t_{RISE} \approx 2.2 \cdot R_{PU} \cdot C_{LOAD}$$

where R_{PU} is the on-resistance of the pull-up transistor. The on-resistance as a function of the V2 voltage at room temperature is estimated using:

$$R_{PU} = \frac{6 \cdot 10^5}{V2 - 1} \Omega$$

with $V2 = 3.3V$, R_{PU} is about 260k. Using 150pF for load capacitance, the rise time is 86 μ s. If the output needs to pull up faster and/or to a higher voltage, a smaller external pull-up resistor may be used. Using a 10k pull-up resistor, the rise time is reduced to 3.3 μ s for a 150pF load capacitance.

The LTC2901-2 has an active pull-up to V2 on the \overline{RST} output. The typical performance curve (RST Pull-Up Current vs V2 curve) demonstrates that the pull-up current is somewhat linear versus the V2 voltage and R_{PU} is estimated to be approximately 625 Ω . A 150pF load capacitance makes the rise time about 206ns.

Watchdog Timer

The watchdog circuit typically monitors a μ P's activity. The μ P is required to change the logic state of the WDI pin on a periodic basis in order to clear the watchdog timer and prevent the \overline{WDO} pin from going low. Whenever \overline{RST} is low, the watchdog timer is cleared and \overline{WDO} is set high. The watchdog timer is started when \overline{RST} pulls high. Subsequent edges received on the WDI pin will clear the watchdog timer. The timer will continue to run until the watchdog timer times out. Once the watchdog timer times out, internal circuitry will bring the \overline{WDO} pin low. \overline{WDO} will remain low and the watchdog timer will remain cleared until the next edge is received on the WDI pin or until \overline{RST} goes low.

To disable the watchdog timer, simply ground the CWT pin (Pin 9). With CWT held at ground, any reset event will force \overline{WDO} high indefinitely. It is safe to leave the WDI pin (Pin 8) unconnected because the weak internal pull-up (10 μ A typ) will pull WDI high. Tying WDI to V1 or ground is also allowed, but grounding the WDI pin will force the pull-up current to be drawn continuously.

Selecting the Reset Timing Capacitor

The reset time-out period is adjustable in order to accommodate a variety of microprocessor applications. The reset time-out period, t_{RST} , is adjusted by connecting a capacitor, C_{RT} , between the CRT pin and ground. The value of this capacitor is determined by:

$$C_{RT} = t_{RST} \cdot 217.4 \cdot 10^{-9}$$

with C_{RT} in Farads and t_{RST} in seconds. The C_{RT} value per millisecond of delay can also be expressed as $C_{RT/ms} = 217.4$ (pF/ms).

Leaving the CRT pin unconnected will generate a minimum reset time-out of approximately 50 μ s. Maximum reset time-out is limited by the largest available low leakage capacitor. The accuracy of the time-out period will be affected by capacitor leakage (the nominal charging current is 2 μ A) and capacitor tolerance. A low leakage ceramic capacitor is recommended.

Selecting the Watchdog Timing Capacitor

The watchdog time-out period is adjustable and can be optimized for software execution. The watchdog time-out period, t_{WD} , is adjusted by connecting a capacitor, C_{WT} , between the CWT pin and ground. Given a specified watchdog time-out period, the capacitor is determined by:

$$C_{WT} = t_{WD} \cdot 50 \cdot 10^{-9}$$

with C_{WT} in Farads and t_{WD} in seconds. The C_{WT} value per millisecond of delay can also be expressed as $C_{WT/ms} = 50$ (pF/ms).

Leaving the CWT pin unconnected will generate a minimum watchdog time-out of approximately 200 μ s. Maximum time-out is limited by the largest available low leakage capacitor. The accuracy of the time-out period will be affected by capacitor leakage (the nominal charging current is 2 μ A) and capacitor tolerance. A low leakage ceramic capacitor is recommended.

Monitoring Power Supply Controller Activity

Figure 7 demonstrates how the LTC2901 can be used to monitor switcher activity. The monitor is configured to supervise 3.3V, 2.5V, 1.8V and one adjustable input.

APPLICATIONS INFORMATION

Because 2.5V does not exist in this application, the V2 input is tied to the V1 (3.3V) input. The feedback voltage on the LTC1772 (0.8V typ) is monitored with the adjustable input (V4). The $\overline{\text{RST}}$ pin will go high 216ms ($C_{\text{RT}} = 47\text{nF}$) after the 3.3V and 1.8V supplies and the feedback voltage are above threshold. Individual input status is available at the COMPX pins.

While the voltage monitors can detect low voltage or shorted inputs, the watchdog circuit can be used to detect an open circuit to the primary load. With the CWT pin

unconnected, the watchdog time-out is approximately 200 μs . At low load currents on the 1.8V supply, the LTC1772 will go into Burst Mode[®] operation. With an open-circuit load, the duty cycle at the gate of M1 will drop, and the pulse spacing will exceed the watchdog time-out period. The $\overline{\text{WDO}}$ pin will go low indicating the low load condition. The $\overline{\text{WDO}}$ pin will return high on the next pulse to the gate of M1. The $\overline{\text{WDO}}$ pin will remain high if the load is restored.

Burst Mode is a registered trademark of Linear Technology Corporation.

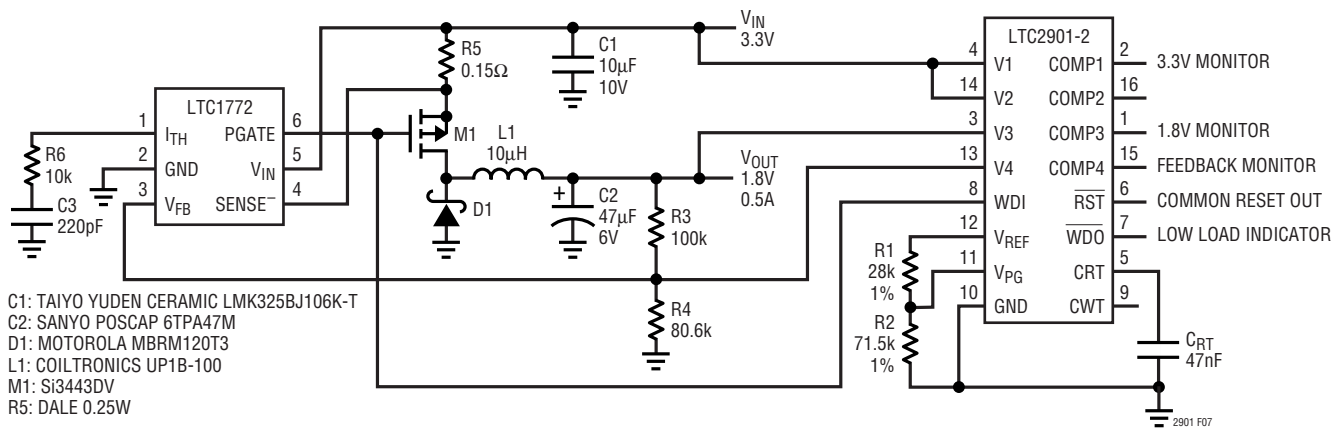
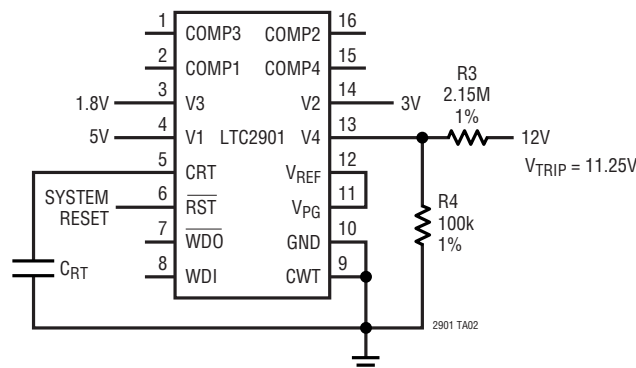

Figure 7. Monitor Input, Output, Feedback Voltage and Low Load Conditions on DC/DC Controller

TYPICAL APPLICATIONS

Quad Supply Monitor with Watchdog Timer Disabled 5V, 3V, 1.8V, 12V (ADJ)



TYPICAL APPLICATIONS

**5V, -5V Monitor with Watchdog Timer Disabled and Unused
V2, V3 Inputs Pulled Above Trip Thresholds**

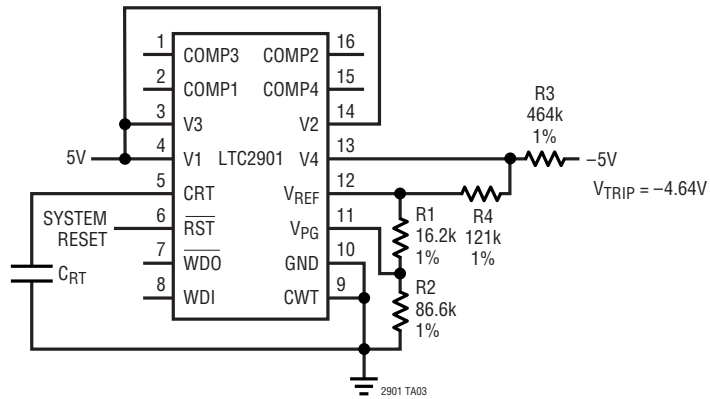

**Quad Supply Monitor with LED Undervoltage Indicators
5V, 3.3V, 2.5V, 1.5V**

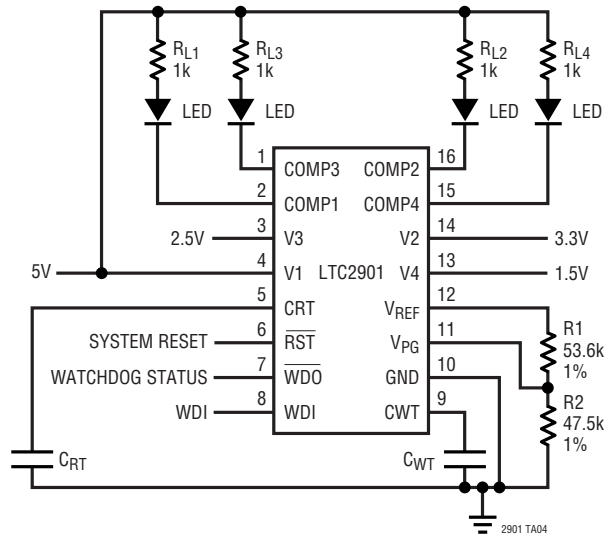

PACKAGE DESCRIPTION

GN Package
16-Lead Plastic SSOP (Narrow .150 Inch)
 (Reference LTC DWG # 05-08-1641)

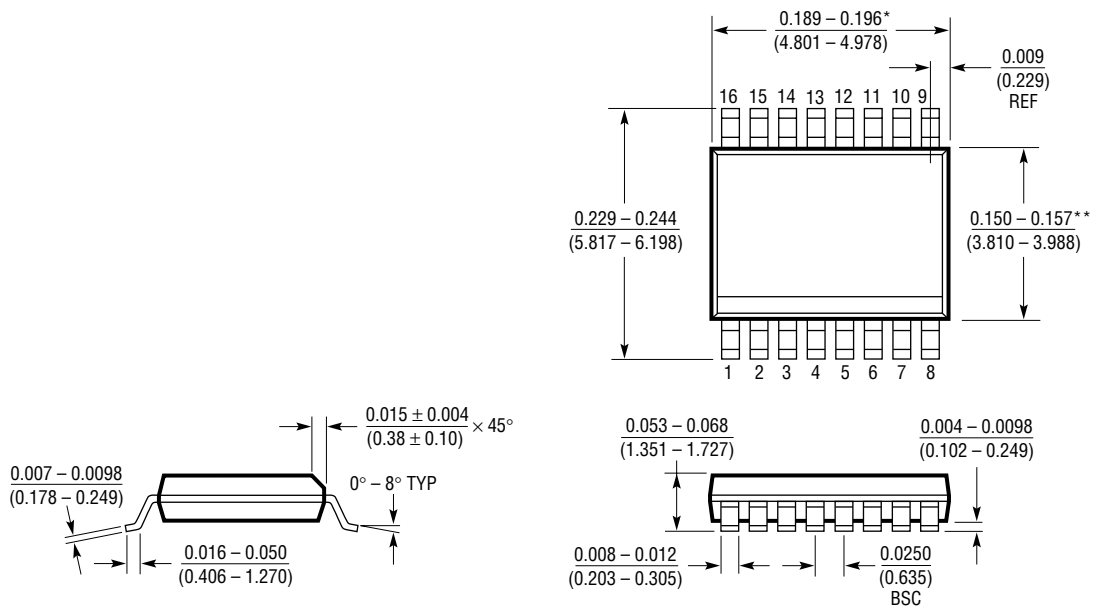

* DIMENSION DOES NOT INCLUDE MOLD FLASH. MOLD FLASH SHALL NOT EXCEED 0.006" (0.152mm) PER SIDE
 ** DIMENSION DOES NOT INCLUDE INTERLEAD FLASH. INTERLEAD FLASH SHALL NOT EXCEED 0.010" (0.254mm) PER SIDE

GN16 (SSOP) 1098

LTC2901

TYPICAL APPLICATION

Monitor Seven Supplies (12V, 5V, 3.3V, 2.5V, 1.8V, -2V, -5.2V) with Sequenced Reset and AC Present Indication

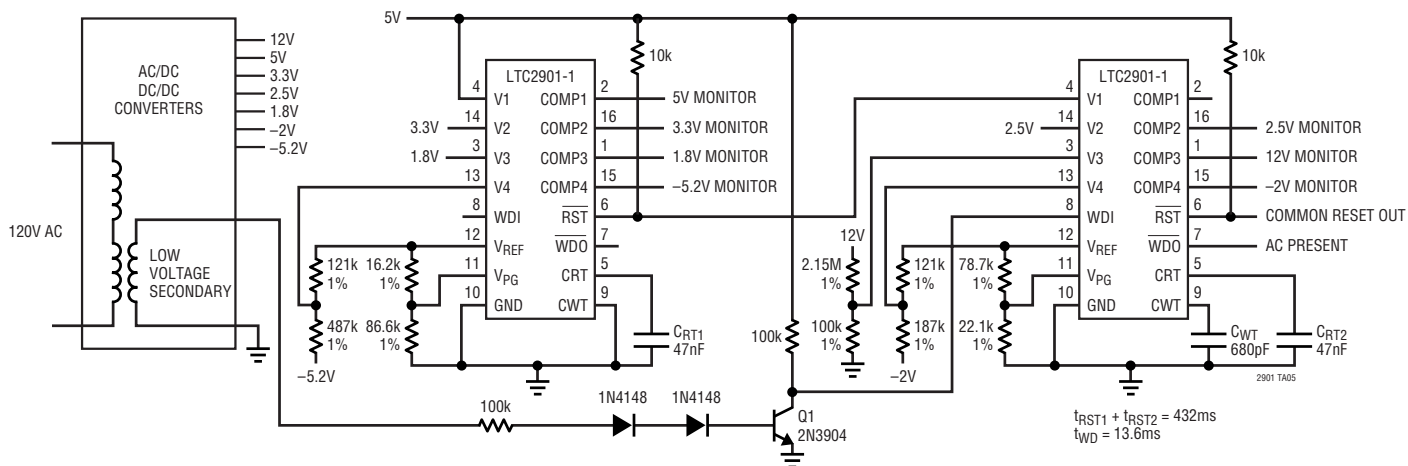

RELATED PARTS

PART NUMBER	DESCRIPTION	COMMENTS
LTC690	5V Supply Monitor, Watchdog Timer and Battery Backup	4.65V Threshold
LTC694-3.3	3.3V Supply Monitor, Watchdog Timer and Battery Backup	2.9V Threshold
LTC699	5V Supply Monitor and Watchdog Timer	4.65V Threshold
LTC1232	5V Supply Monitor, Watchdog Timer and Push-Button Reset	4.37V/4.62V Threshold
LTC1326	Micropower Precision Triple Supply Monitor for 5V, 3.3V and ADJ	4.725V, 3.118V, 1V Thresholds ($\pm 0.75\%$)
LTC1326-2.5	Micropower Precision Triple Supply Monitor for 2.5V, 3.3V and AJD	2.363V, 3.118V, 1V Thresholds ($\pm 0.75\%$)
LTC1536	Precision Triple Supply Monitor for PCI Applications	Meets PCI t_{FAIL} Timing Specifications
LTC1726-2.5	Micropower Triple Supply Monitor for 2.5V, 3.3V and ADJ	Adjustable \overline{RESET} and Watchdog Time-Outs
LTC1726-5	Micropower Triple Supply Monitor for 5V, 3.3V and ADJ	Adjustable \overline{RESET} and Watchdog Time-Outs
LTC1727-2.5/LTC1727-5	Micropower Triple Supply Monitors with Open-Drain Reset	Individual Monitor Outputs in MSOP
LTC1728-1.8/LTC1728-3.3	Micropower Triple Supply Monitor with Open-Drain Reset	5-Lead SOT-23 Package
LTC1728-2.5/LTC1728-5	Micropower Triple Supply Monitors with Open-Drain Reset	5-Lead SOT-23 Package
LTC1985-1.8	Micropower Triple Supply Monitor with Push-Pull Reset Output	5-Lead SOT-23 Package