

Single-Chip Microcontrollers (AMCU)

In Brief . . .

Motorola offers the most comprehensive selection of high-performance single-chip control systems available from a single source. Microcontroller device families range from industry-standard 8-bit controllers to state-of-the-art 16- and 32-bit modular controllers. Within the price and performance categories of each family, there are a variety of on-chip capabilities to match specific applications.

Motorola device families are structured so that upward migration need not involve complete code development. The M68HC11 Family is upward code compatible with M6800 and M6801 software, while the M68HC16 family is source-code compatible with the M68HC11 family. Motorola's newest 8-bit MCU product line, the M68HC08 family, is fully upward object code compatible with the M68HC05 and M6805 families. In addition, M68300 and M68HC16 devices share standard internal modules and bus configurations.

	Page
M68HC11 Family	2.6-2
Modular Microcontroller	2.6-12
The M68HC16 Family	2.6-14
The M68300 Family	2.6-19
Development Tools	2.6-23
Fuzzy Logic	2.6-26
On-Line Help	2.6-26
Third-Party Support	2.6-27



M68HC11 Family

The M68HC11 Family incorporates a flexible central processing unit and a large number of control-oriented on-chip peripherals. M68HC11 MCU are upward code compatible with M6800, M6801, and M68HC05 software.

Central Processing Unit

The M68HC11 CPU is optimized for low power consumption and high-performance operation at bus frequencies up to 4 MHz. Key features include:

- Two 8-bit or one 16-bit accumulator
- Two 16-bit index registers
- Powerful bit-manipulation instructions
- Six powerful addressing modes
 - Immediate, Extended, Direct, Indexed, Inherent, and Relative
- Power saving STOP and WAIT modes
- Memory mapped I/O and special functions
- 16x16 Integer and Fractional Divides
- 8x8 Multiply

Timer

M68HC11 timer architecture is based on a 16-bit free running counter driven through a software-programmable prescaler. Features include multiple Input Captures, Output Compares, Real-Time Interrupt, Pulse Accumulator, and Watchdog functions.

On-Chip Memory

Since its introduction, the M68HC11 Family has provided versatile combinations of popular memory technologies, including the first EEPROM on a CMOS microcontroller. The family has a memory option to fit virtually any application.

- ROM sizes range from 0 to 32K bytes. ROM is typically factory programmed to contain custom software. ROMless versions of most M68HC11 Family members are also available.
- RAM sizes range from 192 bytes to 1.25K bytes. M68HC11 RAM utilizes a fully static design, and all devices feature a standby power supply pin for battery back-up of RAM contents.
- EPROM sizes range from 4K to 32K bytes. EPROM is especially suited to prototype development and small production runs. EPROM versions are available in both windowed and OTP packaging.
- EEPROM sizes range from 0 to 2K bytes. EEPROM is ideal for storage of calibration, diagnostic, data logging, and security information. Each M68HC11 device with EEPROM includes an on-chip charge pump to facilitate single-supply programming and erasing.

Digital-to-Analog Conversion

The M68HC11 Family provides powerful, on-chip, multi-channel A/D converter systems. Multi-conversion and multi-channel options allow single or continuous conversion on single or multiple channels. M68HC11 A/D systems have

eight input channels, and most offer 8-bit resolution, although some provide 10-bit resolution. A 2 channel, 8-bit D/A is also available.

Pulse-Width Modulation

Some M68HC11 Family members have up to six channels of 8-bit PWM. At a 4 MHz bus frequency, signals can be produced from 40 KHz to less than 10 Hz. PWM signals with a period greater than one minute are possible in the 16-bit mode.

Serial Communication

All members of the M68HC11 Family include a Serial Peripheral Interface (SPI) and a Serial Communications Interface (SCI). These on-chip peripherals are designed to minimize CPU intervention during data transfer.

- The SCI is a full duplex UART-type asynchronous system that uses standard Non-Return-to-Zero (NRZ) data format. An on-chip Baud rate generator derives standard rates from the microcontroller oscillator. Both transmitter and receiver are double buffered.
- The SPI is a four-wire synchronous communications interface used for high-speed communication with specialized peripheral devices and other microcontrollers. Data is transmitted and received simultaneously; the Baud rate is software programmable.

Digital I/O and Special Functions

M68HC11 Family I/O is extremely flexible, allowing pins to be configured to match application requirements. Most I/O lines are controlled by bits in a Data Direction Register (DDR) which can configure pins for either input or output. Most lines have a dedicated port data latch.

Some M68HC11 Family members include a 4-channel Direct Memory Access (DMA) and a Memory Management Unit (MMU). The DMA provides fast data transfer between memories and registers, and includes externally mapped memory in the expanded mode. The MMU allows up to 1 megabyte of address space in a physical 64 kbyte allocation. Integrated chip selects help to reduce glue logic.

Several members of the M68HC11 Family also include programmable chip select circuits. These circuits can be used to enable external peripherals whenever an access to a predefined block of memory addresses is made. These circuits help to reduce external logic requirements.

Math Coprocessor

New M68HC11 Family members offer a 16-bit on-chip math coprocessor that accelerates multiply and divide operations by as much as 10 times. The coprocessor functions independently of the CPU and requires no special instructions. The coprocessor is well-suited to low-bandwidth DSP functions such as closed loop control, servo positioning, and signal conditioning.

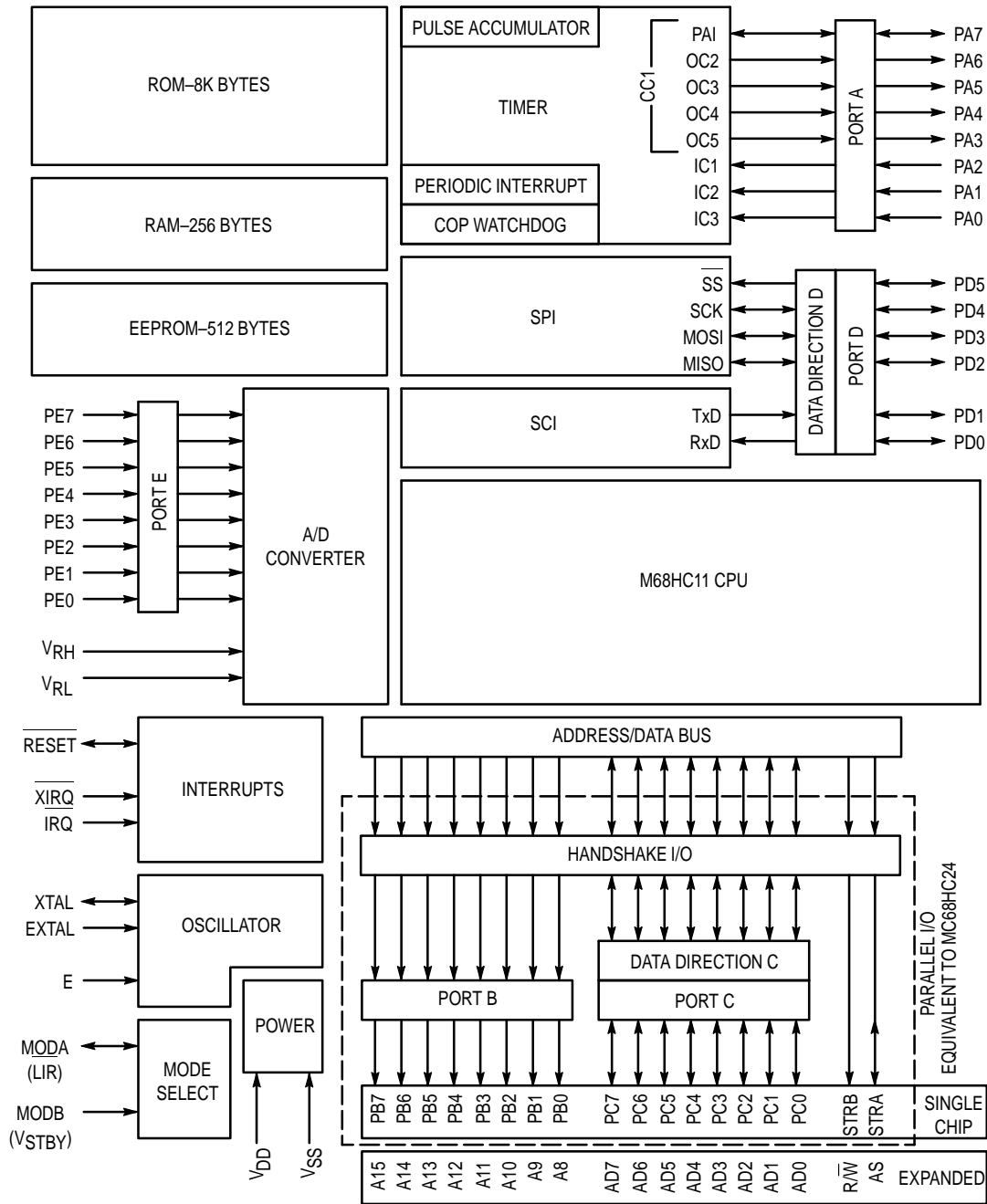

Figure 1. MC68HC11A8 Block Diagram

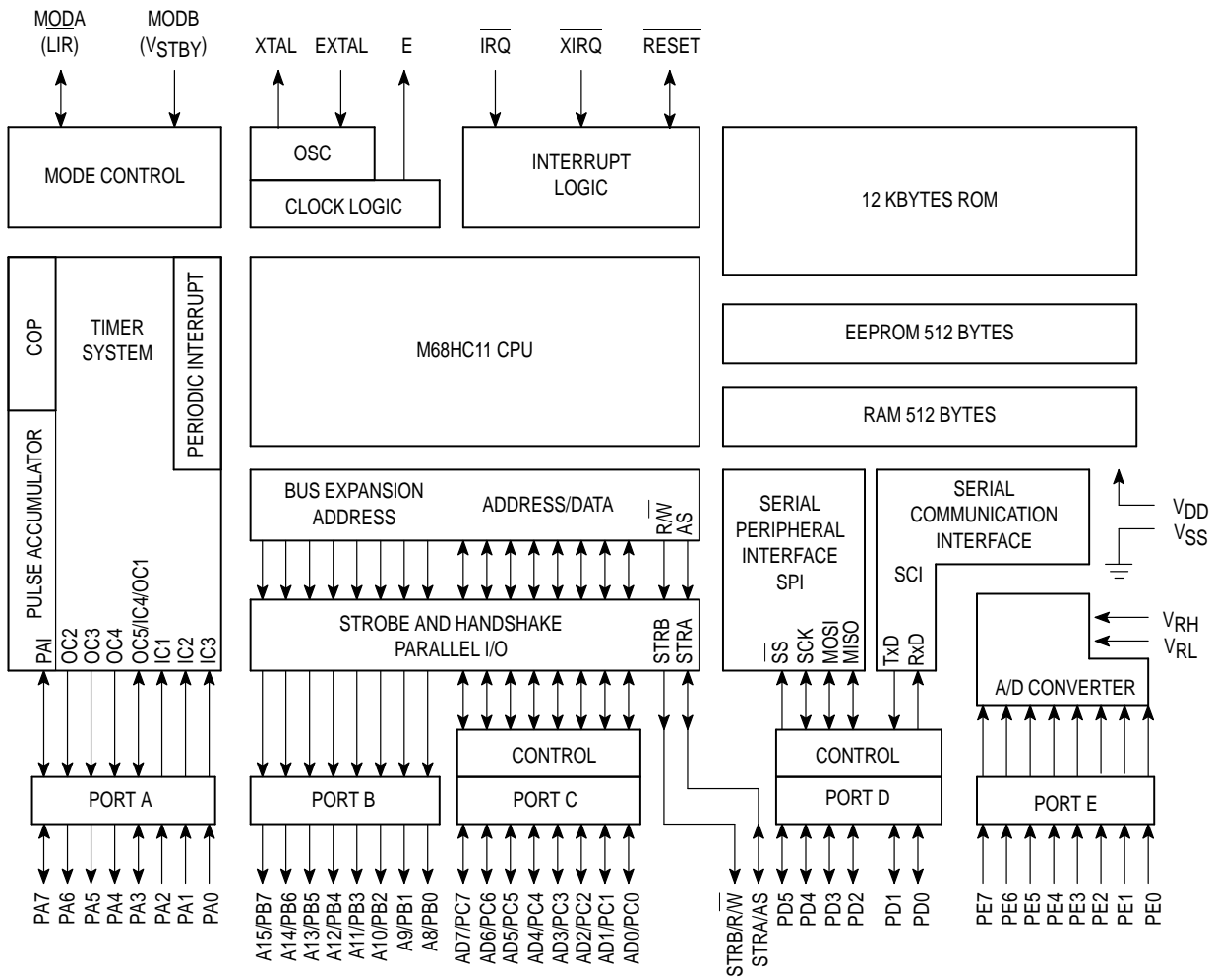

Figure 2. MC68HC11E9 Block Diagram

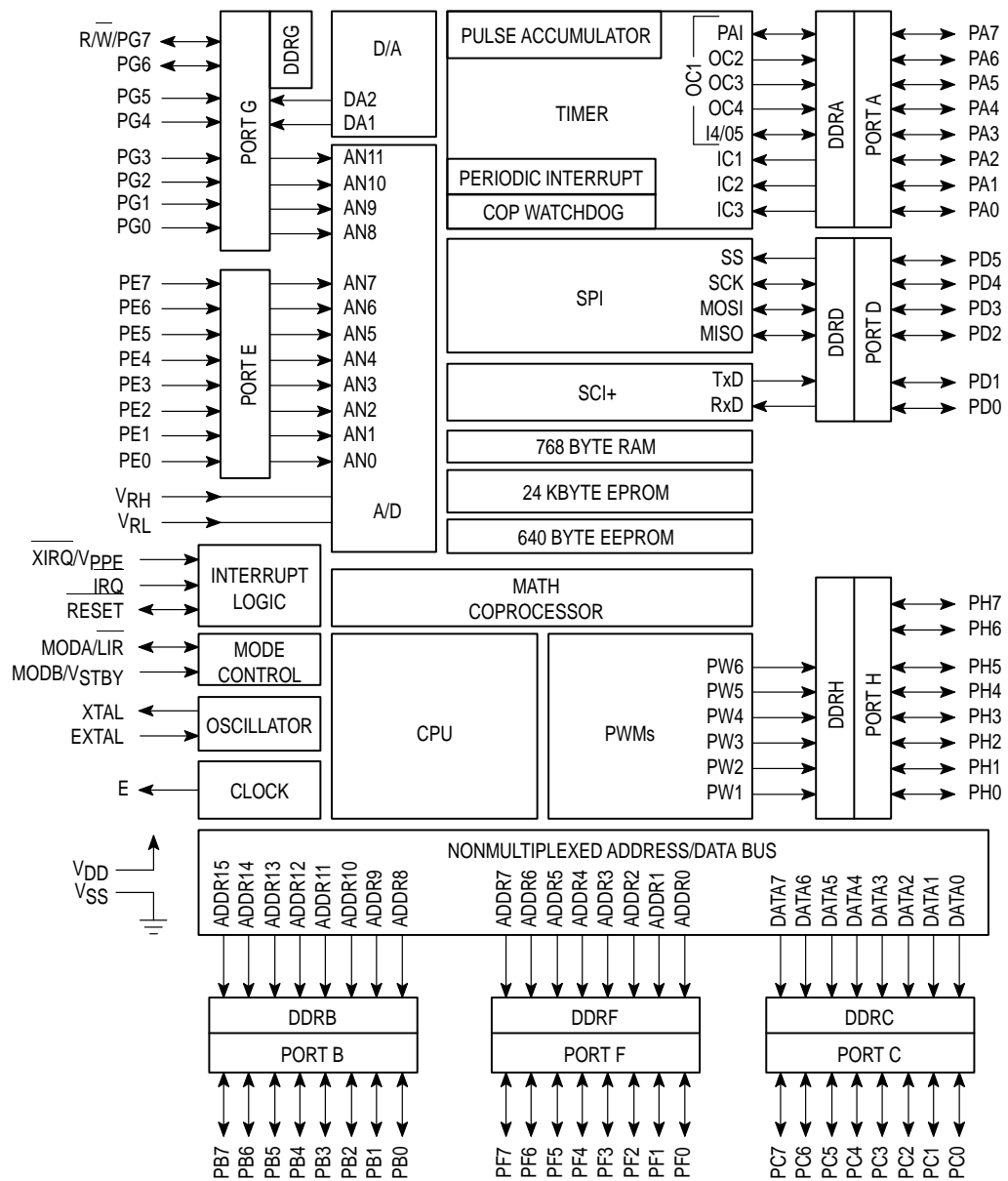

Figure 3. MC68HC711N4 Block Diagram

Table 1. M68HC11 Family Microcontrollers

Part Number	EPROM	RAM	EEPROM	Timer	I/O	Serial	A/D	PWM	Package	Comments
MC68HC11A0	–	256	–	16-Bit – 3 IC, 5 OC, RTI, WDOG Pulse Accumulator	22	SPI, SCI	8 Ch, 8-Bit	–	52-FN 64-FU 48-P	64K External Address Bus, 68HC24 PRU, 3.0 V Version Available
MC68HC11A1	–	256	512	16-Bit – 3 IC, 5 OC, RTI, WDOG Pulse Accumulator	22	SPI, SCI	8 Ch, 8-Bit	–	52-FN 64-FU 48-P	64K External Address Bus, 68HC24 PRU, 3.0 V Version Available
MC68HC11A7	8K	256	–	16-Bit – 3 IC, 5 OC, RTI, WDOG, Pulse Accumulator	38	SPI, SCI	8 Ch, 8-Bit	–	52-FN 64-FU 48-P	3 MHz Version Available, 64K External Address Bus, 68HC24 PRU, 3.0 V Version Available
MC68HC11A8	8K	256	512	16-Bit – 3 IC, 5 OC, RTI, WDOG, Pulse Accumulator	38	SPI, SCI	8 Ch, 8-Bit	–	52-FN 48-P	3 MHz Version Available, Low Voltage Version (3.0–5.5V) at 2 MHz, 64K External Address Bus, 68HC24 PRU
XC68HC11C0	–	256	512	16-Bit – 3/4 IC, 4/5 OC, RTI, WDOG, Pulse Accumulator	36	SPI, SCI	4 Ch, 8-Bit	2 Ch, 8-Bit	68-FN 64-FU	256K Externed Memory, 6 Chip Selects
MC68HC11D0	–	192	–	16-Bit – 3/4 IC, 4/5 OC, RTI, WDOG, Pulse Accumulator	14	SPI, SCI	–	–	44-FB 44-FN 40-P	64K External Address Bus, 68HC27 PRU, 3.0V Version Available.
MC68HC11D3	4K	192	–	16-Bit – 3/4 IC, 4/5 OC, RTI, WDOG, Pulse Accumulator	32	SPI, SCI	–	–	44-FB 44-FN 40-P	3 MHz Version Available, Low Voltage Version (3.0–5.5V) at 2 MHz, 64K External Address Bus, 68HC27 PRU
MC68HC11ED0	–	512	–	16-Bit – 3/4 IC, 4/5 OC, RTI, WDOG, Pulse Accumulator	30	SPI, SCI	–	–	44-FB 44-FN 40-P	Pin Compatible with 68HC11D3
MC68HC11E0	–	512	–	16-Bit – 3/4 IC, 4/5 OC, RTI, WDOG, Pulse Accumulator	22 SCI	SPI, 8-Bit	8 Ch,	–	52-FN	64K External Address Bus, 68HC24 PRU, 3.0 V Version Available.
MC68HC11E1	–	512	512	16-Bit – 3/4 IC, 4/5 OC, RTI, WDOG, Pulse Accumulator	22	SPI, SCI	8 Ch, 8-Bit	–	52-FN 64-FU	64K External Address Bus, EEPROM Block Protect, 68HC24 PRU, 3.0 V Version Available
MC68HC11E8	12K	512	–	16-Bit – 3/4 IC, 4/5 OC, RTI, WDOG, Pulse Accumulator	38 SCI	SPI, 8-Bit	8 Ch,	–	52-FN	3 MHz Version Available, 64K External Address Bus, 3.0 V Version Available
MC68HC11E9	12K	512	512	16-Bit – 3/4 IC, 4/5 OC, RTI, WDOG, Pulse Accumulator	38	SPI, SCI	8 Ch, 8-Bit	–	52-FN 64-FU	EEPROM Block Protect, 3 MHz Version Available, Low Voltage Version (3.0–5.5V) at 2 MHz, 64K External Address Bus
XC68HC11E20	20K	768	512	16-Bit – 3/4 IC, 4/5 OC, RTI, WDOG, Pulse Accumulator	38	SPI, SCI	8 Ch, 8-Bit	–	52-FN 64-FU	3 MHz Mux Bus
MC68HC811E2	–	256	2048	16-Bit – 3/4 IC, 4/5 OC, RTI, WDOG, Pulse Accumulator	38	SPI, SCI	8 Ch, 8-Bit	–	52-FN	EEPROM Block Protect, 64K External Address Bus, 68HC24 PRU
MC68HC11F1	–	1K	512	16-Bit – 3/4 IC, 4/5 OC, RTI, WDOG, Pulse Accumulator	54	SPI, SCI	8 Ch, 8-Bit	–	68-FN 80-FU	Programmable Chip Selects, EEPROM Block Protect, 64K External Address Bus, 68HC27 PRU, 4 MHz Non-Mux Address/Data Bus
PC68HC11G0	–	–	512	16-Bit – 3/4 IC, 4/5 OC, RTI, WDOG, Pulse Accumulator	38	SPI, SCI	8 Ch, 10-Bit	4 Ch, 8-Bit	84-FN 80-FU	

Table 1. M68HC11 Family Microcontrollers (continued)

Part Number	EPROM	RAM	EEPROM	Timer	I/O	Serial	A/D	PWM	Package	Comments
PC68HC11G5	16K	512	–	16-Bit – 3/4 IC, 4/5 OC, RTI, WDOG, Pulse Accumulator	66	SPI, SCI	8 Ch, 10-Bit	4 Ch, 8-Bit	84-FN 80-FU	
PC68HC11G7	24K	512	–	16-Bit – 3/4 IC, 4/5 OC, RTI, WDOG, Pulse Accumulator	66	SPI, SCI	8 Ch, 10-Bit	4 Ch, 8-Bit	84-FN 80-FU	
PC68HC11J6	16K	–	512	16-Bit – 3/4 IC, 4/5 OC, RTI, WDOG, Pulse Accumulator	29	SPI, SCI	8 Ch, 8-Bit	4 Ch, 8-Bit	84-FN 80-FU	
MC68HC11K0	–	768	–	16-Bit – 3/4 IC, 4/5 OC, RTI, WDOG, Pulse Accumulator	37	SPI, SCI	8 Ch, 8-Bit	4 Ch, 8-Bit	84-FN 80-FU	4 MHz Non-Mux Address/Data Bus, Chip Selects, Extended Memory Map, 68HC27 PRU, 3.0 V Version Available
MC68HC11KA0	–	768	–	16-Bit – 3/4 IC, 4/5 OC, RTI, WDOG, Pulse Accumulator	26	SPI, SCI	8 Ch, 8-Bit	4 Ch, 8-Bit	68-FN 64-FU	4 MHz Non-Mux Address/Data Bus, Chip Selects, Extended Memory Map, 68HC27 PRU
MC68HC11K1	–	768	640	16-Bit – 3/4 IC, 4/5 OC, RTI,WDOG, Pulse Accumulator	37	SPI, SCI	8 Ch, 8-Bit	4 Ch, 8-Bit	84-FN 80-FU	4 MHz Non-MuxBus,Chip Selects, EEPROM Block Protect, Extended Memory Map, 68HC27 PRU, 3.0 V Version Available
MC68HC11KA1	–	768	640	16-Bit – 3/4 IC, 4/5 OC, RTI,WDOG, Pulse Accumulator	26	SPI, SCI	8 Ch, 8-Bit	4 Ch, 8-Bit	68-FN 64-FU	4 MHz Non-Mux Address/Data Bus, Chip Selects,EEPROM Block Protect, Extended Memory Map, 68HC27 PRU
MC68HC11K3	24K	768	–	16-Bit – 3/4 IC, 4/5 OC, RTI, WDOG, Pulse Accumulator	62	SPI, SCI	8 Ch, 8-Bit	4 Ch, 8-Bit	84-FN 80-FU	4 MHz Non-Mux Address/Data Bus, Chip Selects, Extended Memory Map, 68HC27 PRU, 3.0V Version Available
MC68HC11KA3	24K	768	–	16-Bit – 3/4 IC, 4/5 OC, RTI, WDOG, Pulse Accumulator	51	SPI, SCI	8 Ch, 8-Bit	4 Ch, 8-Bit	68-FN 64-FU	4 MHz Non-Mux Address/Data Bus, Chip Selects, Extended Memory Map, 68HC27 PRU
MC68HC11K4	24K	768	640	16-Bit – 3/4 IC, 4/5 OC, RTI, WDOG, Pulse Accumulator	62	SPI, SCI	8 Ch, 8-Bit	4 Ch, 8-Bit	84-FN 80-FU	4 MHz Non-Mux Bus, Low Voltage Version (3.0–5.5V) at 3 MHz, Chip Selects, EEPROM Block Protect, Extended Memory Map, 68HC27 PRU
MC68HC11KA4	24K	768	640	16-Bit – 3/4 IC, 4/5 OC, RTI, WDOG, Pulse Accumulator	51	SPI, SCI	8 Ch, 8-Bit	4 Ch, 8-Bit	68-FN 64-FU	4 MHz Non-Mux Address/Data Bus, Chip Selects, EEPROM Block Protect
MC68HC11L0	–	512	–	16-Bit – 3/4 IC, 4/5 OC,RTI, WDOG, Pulse Accumulator	30	SPI, SCI	8 Ch, 8-Bit	–	68-FN 64-FU	64K External Address Bus, 68HC24 PRU, 3.0 V Version Available
MC68HC11L1	–	512	512	16-Bit – 3/4 IC, 4/5 OC,RTI, WDOG, Pulse Accumulator	46	SPI, SCI	8 Ch, 8-Bit	–	68-FN 64-FU	64K External Address Bus, EEPROM Block Protect, 68HC24 PRU, 3.0 V Version Available
MC68HC11L5	16K	512	–	16-Bit – 3/4 IC, 4/5 OC, RTI, WDOG, Pulse Accumulator	46	SPI, SCI	8 Ch, 8-Bit	–	68-FN 64-FU	64K External Address Bus, 68HC24 PRU, 3.0 V Version Available
MC68HC11L6	16K	512	512	16-Bit – 3/4 IC, 4/5 OC, RTI, WDOG, Pulse Accumulator	46	SPI, SCI	8 Ch, 8-Bit	–	68-FN 64-FU	3 MHz Version Available, Low Voltage Version (3.0–5.5V) at 2 MHz, 64K External Address Bus, 68HC24 PRU

Table 1. M68HC11 Family Microcontrollers (continued)

Part Number	EPROM	RAM	EEPROM	Timer	I/O	Serial	A/D	PWM	Package	Comments
MC68HC11M2	32K	1.25K	–	16–Bit – 3/4 IC, 4/5 OC, RTI, WDOG, Pulse Accumulator	62	SPI, 2–SCI	8 Ch, 8–Bit	4 Ch, 8–Bit	84–FN 80–FU	16–Bit Math Coprocessor, 4 MHz Non–Mux Bus, 4 Ch DMA Controller
XC68HC11N4	24K	768	640	16–Bit – 3/4 IC, 4/5 OC, RTI, WDOG, Pulse Accumulator	62	SPI, SCI	12 Ch, 8–Bit	6 Ch, 8–Bit	84–FN 80–QFP	16–Bit Math Coprocessor, 4 MHz Non–Mux Bus, 2 Ch 8–Bit D/A
XC68HC11P2	32K	1K	640	16–Bit – 3/4 IC, 4/5 OC, RTI, WDOG, Pulse Accumulator	62	SPI, 3–SCI	8 Ch, 8–Bit	4 Ch, 8–Bit	84–FN 80–FU	PLL Clock Option

Table 2. M68HC11 One–Time Programmable/Emulator Microcontrollers

Part Number	EPROM	RAM	EEPROM	Timer	I/O	Serial	A/D	PWM	Package	Comments
PC68HC711D3	4K	192	–	16–Bit – 3/4 IC, 4/5 OC, RTI, WDOG, Pulse Accumulator	32	SPI, SCI	–	–	44–FB 44–FN 40–P	64K External Address Bus
PC68HC711E9	12K	512	512	16–Bit – 3/4 IC, 4/5 OC, RTI, WDOG, Pulse Accumulator	38	SPI, SCI	8 Ch, 8–Bit	–	52–FN 64–FU	EEPROM Block Protect, 64K External Address Bus
PC68HC711E20	20K	768	512	16–Bit – 3/4 IC, 4/5 OC, RTI, WDOG, Pulse Accumulator	38	SPI, SCI	8 Ch, 8–Bit	–	52–FN 52–FS 64–FU	EEPROM Block Protect, 64K External Address Bus
PC68HC711G5	16K	512	–	16–Bit – 3/4 IC, 4/5 OC, RTI, WDOG, Pulse Accumulator	66	SPI, SCI	8 Ch, 10–Bit	4 Ch, 8–Bit	84–FN 84–FS	
PC68HC711J6	16K	512	–	16–Bit – 3/4 IC, 4/5 OC, RTI, WDOG, Pulse Accumulator	54	SPI, SCI	–	–	68–FN 68–FS	1 Chip Select
PC68HC711K4	24K	768	640	16–Bit – 3/4 IC, 4 / 5 O C , R T I Pulse Accumulator	62	SPI, SCI	8 Ch, 8–Bit	4 Ch, 8–Bit	84–FN 84–FS 80–FU	4 MHz Non–Mux Bus, EEPROM Block Protect, Chip Selects, Extended Memory Map
PC68HC711L6	16K	512	512	16–Bit – 3/4 IC, 4/5 OC, RTI, WDOG, Pulse Accumulator	46	SPI, SCI	8 Ch, 8–Bit	–	68–FN 68–FS 64–FU	EEPROM Block Protect, 64K External Address Bus
PC68HC711M2	32K	1.25K	–	16–Bit – 3/4 IC, 4/5 OC, RTI, WDOG, Pulse Accumulator	62	SPI, SCI	8 Ch, 8–Bit	–	84–FN 84–FS 80–FU	16–Bit Math Coprocessor, 4 MHz Non–Mux Bus, 4 Ch DMA Controller
PC68HC711N4	24K	768	640	16–Bit – 3/4 IC, 4/5 OC, RTI, WDOG, Pulse Accumulator	62	SPI, SCI	12 Ch, 8–Bit	6 Ch, 8–Bit	84–FN 84–FS	16–Bit Math Coprocessor, 4 MHz Non–Mux Bus, 2 Ch 8–Bit D/A
XC68HC711P2	32K	1K	640	16–Bit – 3/4 IC, 4/5 OC, RTI, WDOG, Pulse Accumulator	62	SPI, SCI	8 Ch, 8–Bit	4 Ch, 8–Bit	84–FN 84–FS 88–FU	PLL Clock

Definitions for Tables 3 and 4

General Definitions

ADC	Analog to Digital Converter Module
A/D	Analog to Digital Converter
CPU16	16 bit Central Processing Unit
CPU32	32 bit Central Processing Unit
D/A	Digital to Analog Converter
DMA	Direct Memory Access
GPT	General-Purpose Timer
IC	Input Capture
IIC	Inter-Integrated Circuit
MCCI	Multi-Channel Communication Interface
PLL	Phase Lock Loop
OC	Output Capture
POQ	Preferred Order Quantity Multiple
PWM	Pulse Width Modulation
QSM	Queued Serial Module
RPSCIM	Reduced Pin Count SCIM
RTC	Real-Time Clock
RTI	Real-Time Interrupt
SCI	Serial Communication Interface
SCIM	Single Chip Integration Module
SIM	System Integration Module
SPI	Serial Peripheral Interface
TPU	Time Processing Unit
UART	Universal Asynchronous Receiver/Transmitter
WDOG	Watch Dog Timer

Package Definitions

FB	10x10 mm Quad Flat Pack (QFP)
FC	Fine Pitch Plastic Quad Flat Pack (PQFP)
FD	Plastic Quad Flat Pack in Molded Carrier Ring
FE	Ceramic Quad Flat Pack (CQFP)
FM	Molded Carrier Flat Pack (CQFP)
FN	Plastic Leaded Chip Carrier (PLCC)
FS	Windowed Cerquad (Ceramic LCC)
FT	28x28 mm Quad Flat Pack (QFP)
FU	14x14 mm Quad Flat Pack (QFP)
FV	20x20 mm Quad Flat Pack (QFP)
L	Ceramic
P	Dual-in-Line Plastic
PB	Thin Quad Flat Pack (TQFP) 10x10 mm
PU	Thin Quad Flat Pack (TQFP) 14x14 mm
PV	Thin Quad Flat Pack (TQFP) 20x20mm
S	Cerdip (windowed or non-windowed)
TH	16x16 mm Quad Flat Pack (QFP)

M6800 Series Microprocessors and Peripherals

These devices are a testament to the staying power of Motorola microtechnology. The original MC6800 was introduced in 1975, and is still in demand today. Quality M6801, M6804 and M6805 systems have been performing

reliably in automotive, industrial, and office equipment applications for years. Each of these devices can be combined with various peripherals to meet the requirements of a microcontroller design.

Table 3. M6801 and M6803 (HMOS)

Part Number	ROM	RAM	EEPROM	Timer	Serial	A/D	I/O	Bus Speed, MHz	Package	Comments
MC6801	2048	192	0	16 bit: 1 IC, 1 OC	SCI	No	29	0.5–2.0	40 P	
MC68701	0	128	2048	16 bit: 1 IC, 1 OC	SCI	No	29	0.5–2.0	40 P	
MC6803	0	192	0	16 bit: 1 IC, 1 OC	SCI	No	13	0.5–2.0	40 P	
MC6801U4	4096	256	0	16 bit: 2 IC, 3 OC	SCI	No	29	0.5–1.25	40 P	
MC68701U4	0	128	4096	16 bit: 2 IC, 3 OC	SCI	No	29	0.5–1.25	40 P	
MC6803U4	0	256	0	16 bit: 2 IC, 3 OC	SCI	No	13	0.5–1.25	40 P	

Table 4. 8–Bit MPU/Peripherals

Device	Pins	Package	Part Description	Speed
MC68B00	40	P	8 Bit MPU, Addresses 64K Memory, 1 or 2 MHz Versions	2 MHz
MC6802	40	P	MC6800 + Int. Clock Oscillator; 128 Bytes RAM	1 MHz
MC68B09	40	P	High Performance MPU, 10 Powerful Addressing Modes	2 MHz
MC68B09E	40	P	MC6809 With External Clock Input for External Sync.	2 MHz
MC68B21	40	P	Peripheral Interface Adapter	2 MHz
MC68B40	40	P	Programmable Timer Module Contains 3 16–Bit Timers	2 MHz
MC6845	40	P	CRT Ctrl, Refresh Memory Addressing; 2nd Source HD6845R	1 MHz
MC68B50	40	P	Asynchronous Communication Interface Adaptor	2 MHz
MC68HC24	40, 44	P, FN	MC68HC11 Port Replacement (Expanded Mode) for A8, E9	2 MHz
MC68HC27	46, 68	FU, FN	Port Replacement for D3, K4, F1	2 MHz
MC68HCB34	40	P, FN	256 Byte Dual Port RAM, 6 Semaphore Registers	2 MHz
MC68B10	24	P	128 x 8 Random Access Memory	2 MHz
MC68B44	40	P	Direct Memory Access Controller	2 MHz
MC68B488	40	P	General Purpose Interface Adapter	2 MHz
MC68B52	24	P	Synchronous Serial Data Adapter	2 MHz
MC68B54	28	P	Advanced Data Link Controller	2 MHz

Table 5. M6805 (HMOS) Microprocessors

Part Number	ROM	RAM	EEPROM	Timer	Serial	A/D	I/O	Bus Speed, MHz	Package	EPROM or EEPROM Version	Comments
MC6805P2	1K	64	0	8–Bit	–	No	20	0.1–1.0	28–P 28–FN	705P3	LVI Option
MC6805P6	2K	64	0	8–Bit	–	No	20	0.1–1.0	28–P	705P3	LVI Option
MC6805R2	2K	64	0	8–Bit	–	Yes	32	0.1–1.0	40–P 44–FN	705R3	LVI Option, Prog. Prescaler Option
MC6805R3	4K	112	0	8–Bit	–	Yes	32	0.1–1.0	40–P 44–FN	705R3	7–Bit Prescaler, LVI Option
MC6805R6	4K	112	0	8–Bit, WDOG	–	Yes	32	0.1–1.0	40–P 44–FN	705R3	7–Bit Prescaler, LVI Option
MC6805S2	1K	64	0	16–Bit, 8–Bit	SPI	Yes	16	0.1–1.0	28–P	705S3	15–Bit Prescaler, LVI
MC6805S3	4K	104	0	2 8–Bit, 16–Bit	SPI	Yes	21	0.1–1.0	28–P	705S3	1 Extra 8–Bit Timer
MC6805U2	2K	64	0	8–Bit	–	No	32	0.1–1.0	40–P 44–FN	705U3	LVI Option
MC6805U3	4K	112	0	8–Bit	–	No	32	0.1–1.0	40–P 44–FN	705U3	7–Bit Prescaler, LVI Option

Table 6. 8–Bit MPU/Peripherals

Device	Pins	Package	Part Description
MC14618	24	P	Real Time Clock, 50 Bytes RAM, Programmable Square Wave
MC146818A	24, 28	P, FN	Enhanced Version of the MC146818
MC146823	40, 44	P, FN	Three 8–Bit Ports, Handshake Control Logic
MC146805E2	40, 44	P, FN	CMOS 8–Bit Microprocessor
MC68HC68L9	80	FU	LCD Expansion to the MC05L9

Modular Microcontrollers

Modular microcontrollers are another of the innovations that make Motorola a leader in single-chip control systems. Modular controllers are built up from standard modules that interface via a common intermodule bus (IMB). The modular concept allows rapid design and manufacture of controllers tailored for specific applications.

Intermodule Bus Peripherals

Each modular microcontroller incorporates a state-of-the-art pipelined CPU module, a sophisticated integration module, and a number of special-purpose modules. The rapidly-growing library of special-purpose modules includes programmable timers, serial communication interfaces, analog-to-digital converters, and a variety of memory modules.

Central Processing Units

CPU16

- 16-Bit Architecture
- Full Set of 16-Bit Instructions
- Three 16-Bit Index Registers
- Two 16-Bit Accumulators
- One Megabyte of Program Memory and One Megabyte of Data Memory
- Source code compatible with the M68HC11 CPU
- Control-Oriented Digital Signal Processing Capability
- High-Level Language Support
- Fast Interrupt Response Time
- Fully Static Implementation
- Low Power Stop Operation
- Background Debugging Mode
- Hardware Breakpoint Signal

CPU32

- 32-Bit Internal Data Path and Arithmetic Hardware
- 32-Bit Internal Address Bus – 24-Bit External Address Bus
- Eight 32-Bit General-Purpose Data Registers
- Seven 32-Bit General-Purpose Address Registers
- Separate User and Supervisor Stack Pointers and Address Spaces
- Separate Program and Data Address Spaces
- Virtual Memory Implementation
- Enhanced Addressing Modes
- Object Code Compatible with M68000 Family
- Improved Exception Handling for Controller Applications
- Rich Instruction Set
- Fully Static Implementation
- Low Power Stop Operation
- Background Debugging Mode
- Hardware and Software Breakpoints
- Trace on Change of Flow

Integration Modules

System Integration Module (SIM)

- Manages controller internal and external bus interfaces
- Provides device interrupt arbitration
- Spurious interrupt monitor

- Twelve programmable chip-select outputs
- Watchdog timer, clock monitor, and bus monitor
- PLL clock synthesizer

Single-Chip Integration Module (SCIM)

- Manages controller internal and external bus interfaces
- Provides device interrupt arbitration
- Spurious interrupt monitor
- Single-chip operation with address and data bus pins configured as I/O ports
- Optional Fully or Partially-expanded bus operation
- Nine general-purpose chip select outputs
- Emulation mode chip-select outputs can be used to address a port replacement unit and external emulation RAM
- Watchdog timer, clock monitor, and bus monitor
- PLL clock synthesizer
- Interrupt request inputs can be configured for edge or level detection
- Reduced pin SCIM (RPSCIM) available with 5 chip selects

Timers

Time Processor Unit (TPU)

- On-chip microengine dedicated to high-speed timing tasks
- Two independent 16-bit counters used as basis for timing tasks
- Real-time task scheduler
- Executes a programmed series of functions to perform complex tasks
- Each of 16 orthogonal channels can perform available time functions
- Functions contained in dedicated control store or in MCU RAM
- TPU communicates to CPU via dual port RAM

General Purpose Timer (GPT)

- Two 16-bit free-running counters
- Three input capture channels
- Four output compare channels
- One input capture/output compare channel
- One pulse accumulator/event counter input
- Two pulse-width modulation outputs
- Pulse accumulator input

Configurable Timer Module (CTM)

- Modular timer system combining different configurations of timer submodules:
- CPSM-6 TAP counter prescaler
- FCSM-16-bit free running up counter
- MCSM-16-bit modulus up counter
- SASM-(Single Action) two I/O pins for 16-bit input capture or output compare functions
- DASM-(Dual Action) one I/O pin for 16-bit I/C, O/C, PWM, or output function

Timer Module (TM)

- 16-bit free-running counter with 8-bit prescaler
- Two TM can be externally cascaded to increase count width
- Software selected input capture, output compare, pulse accumulation, event counting, or pulse-width modulation functions

Communication Modules

Queued Serial Module (QSM)

- Queued full-duplex, synchronous three-line SPI with dedicated RAM
- Standard, asynchronous NRZ-format SCI
- Polled and interrupt-driven operation
- Pins can be configured as a parallel I/O port

Multi-Channel Communications Interface (MCCI)

- One full-duplex synchronous three-line SPI
- Two independent standard, asynchronous NRZ-format SCI
- Polled and interrupt-driven operation
- Pins can be configured as a parallel I/O port

Dual Universal Asynchronous/Synchronous Receiver Transmitter (DUART)

- Dual NRZ Serial RS-232C channels
- Independently programmable TxD and Receiver Transmitter (DUART)
- RxD Baud rates for each channel up to 76.8K Baud
- Optional external input pins provide baud clock
- Transmit operations are double buffered, and receive operations are quadruple buffered
- RTS and CTS signals are directly supported

Analog-to-Digital Conversion Modules

Analog-to-Digital Converter (ADC)

- 8 or 10 bits of resolution
- Eight input channels
- Eight result registers
- Three result alignment formats
- Eight automated conversion modes
- Programmable sample and hold times are provided
- Three result alignment modes

Queued Analog-to-Digital Converter (QADC)

- 10 bits of resolution
- 16 analog input channels (up to 27 if multiplexed externally)
- Two independent conversion queues
- 32 result registers (16 per queue)
- Three result alignment formats

- Queued conversions can be performed continuously or can be retriggered by software or the QADC module periodic interval timer and external trigger
- Programmable sample and hold times
- Alternate voltage references

Specialized Control Modules

Direct Memory Access (DMA)

- Provides low-latency transfer to external peripheral or for memory-memory data transfer
- Two independent DMA channels with full programmability

Memory Modules

Standby RAM (SRAM)

- Fast Static RAM maintained by voltage from standby voltage pin
- Available in 1K, 1.5K, 2K, 3.5K, and 4K blocks
- Fast (2 clock) access speed
- Byte, word, and long-word operations supported

Standby RAM with TPU Emulation (TPURAM)

- Fast Static RAM maintained by voltage from standby voltage pin
- Available in 1K, 1.5K, 2K, 3.5K, and 4K blocks
- Fast termination (2 clock) access speed
- Supports TPU microcode ROM emulation
- Byte, word, and long-word operations supported

Masked ROM (MRM)

- Custom-masked non-volatile 16-bit wide memory
- Available in 4K increments from 8K to 48K bytes
- Fast (2 clock) access speed
- Byte, word, and long-word operations supported
- Boot ROM capability

Flash EEPROM (FLASH)

- Word programmable, bulk erasable non-volatile 16-bit wide memory
- Available in 8K increments from 8K to 64K bytes
- Fast (2 clock) access speed
- Byte, word, and long-word operations supported
- Boot ROM capability
- External 12 volt programming/erasure source required

Block Erasable Flash EEPROM (BEFLASH)

- Available in 8K increments from 8K to 64K bytes
 - Eight independently-erasable blocks
 - Fast termination (2 clock) access speed
 - Byte, word, and long-word operations supported
 - Byte/Word programming with 12 volt external input
-

The M68HC16 Family

The M68HC16 family is designed for embedded control applications. Each M68HC16 MCU incorporates a true 16-bit CPU module (CPU16) that is upwardly code-compatible with the M68HC11 CPU, a sophisticated integration module, and a number of special-purpose modules. M68HC16 devices

can be placed in low-power stop mode to minimize power consumption during periods of inactivity. The M68HC16 family provides the flexibility and features of the M68300 family, and also provides a convenient way for users of M68HC11 devices to move up to 16-bit performance.

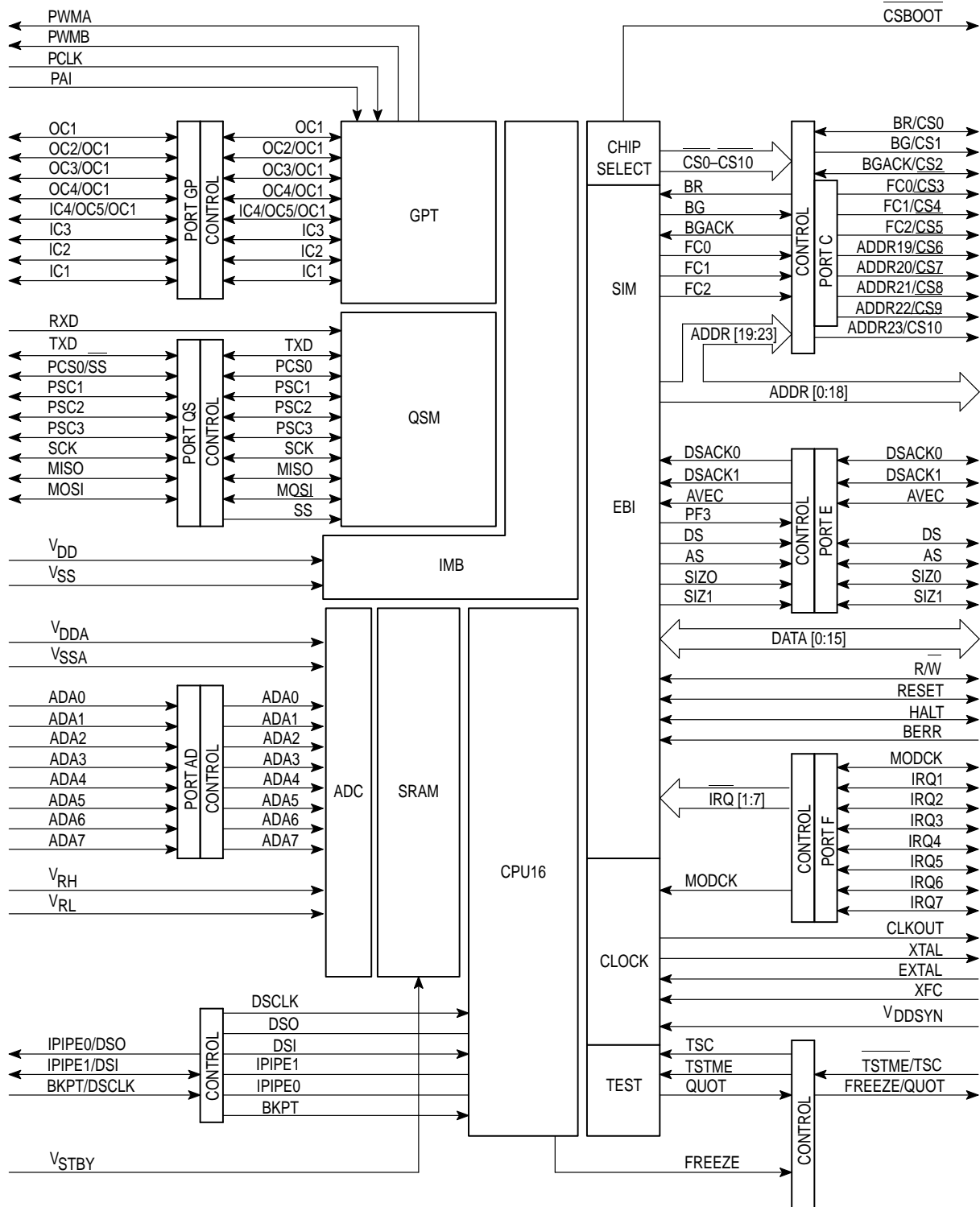

Figure 4. MC68HC16Z1 Block Diagram

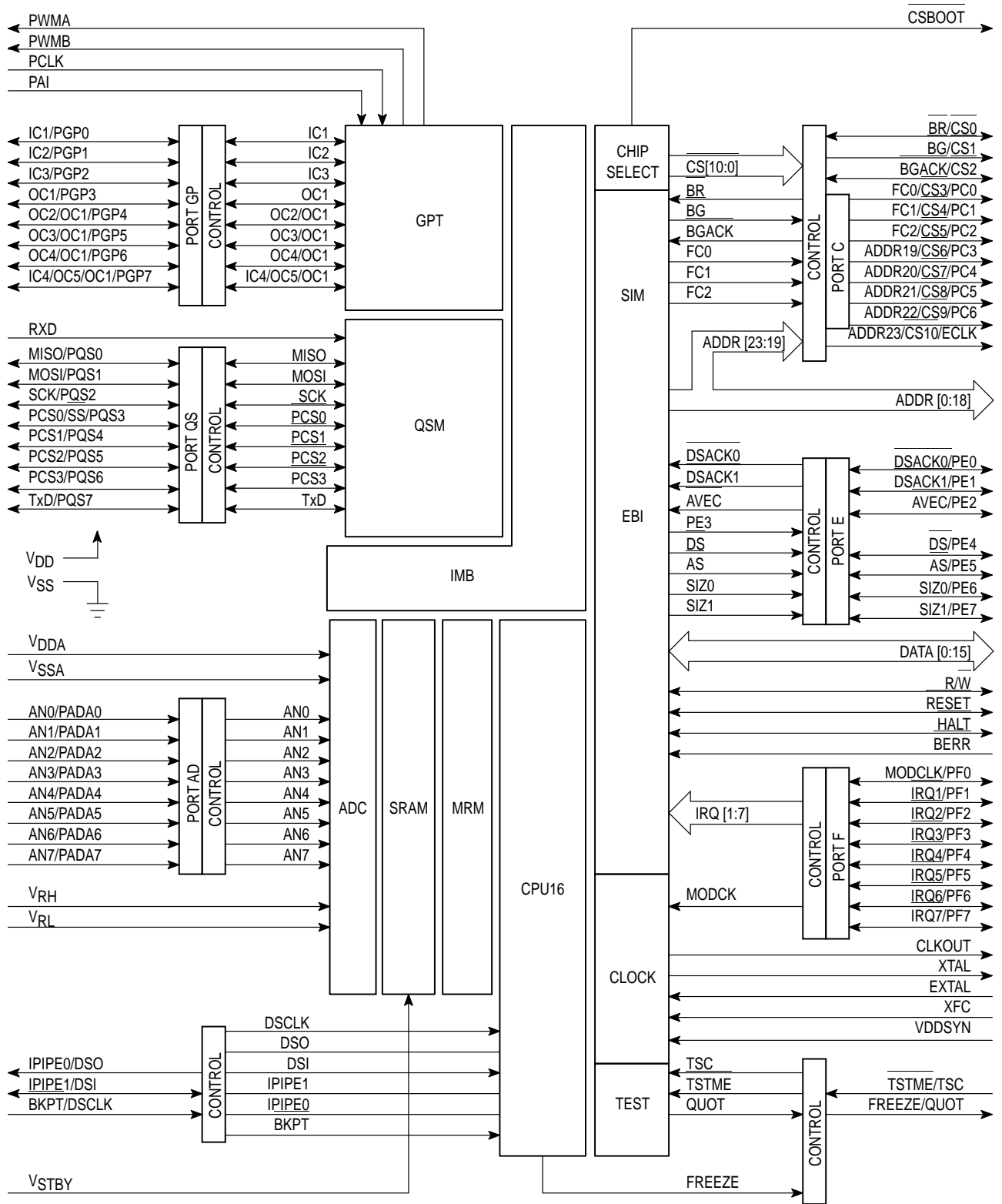

Figure 5. MC8HC16Z2 Block Diagram

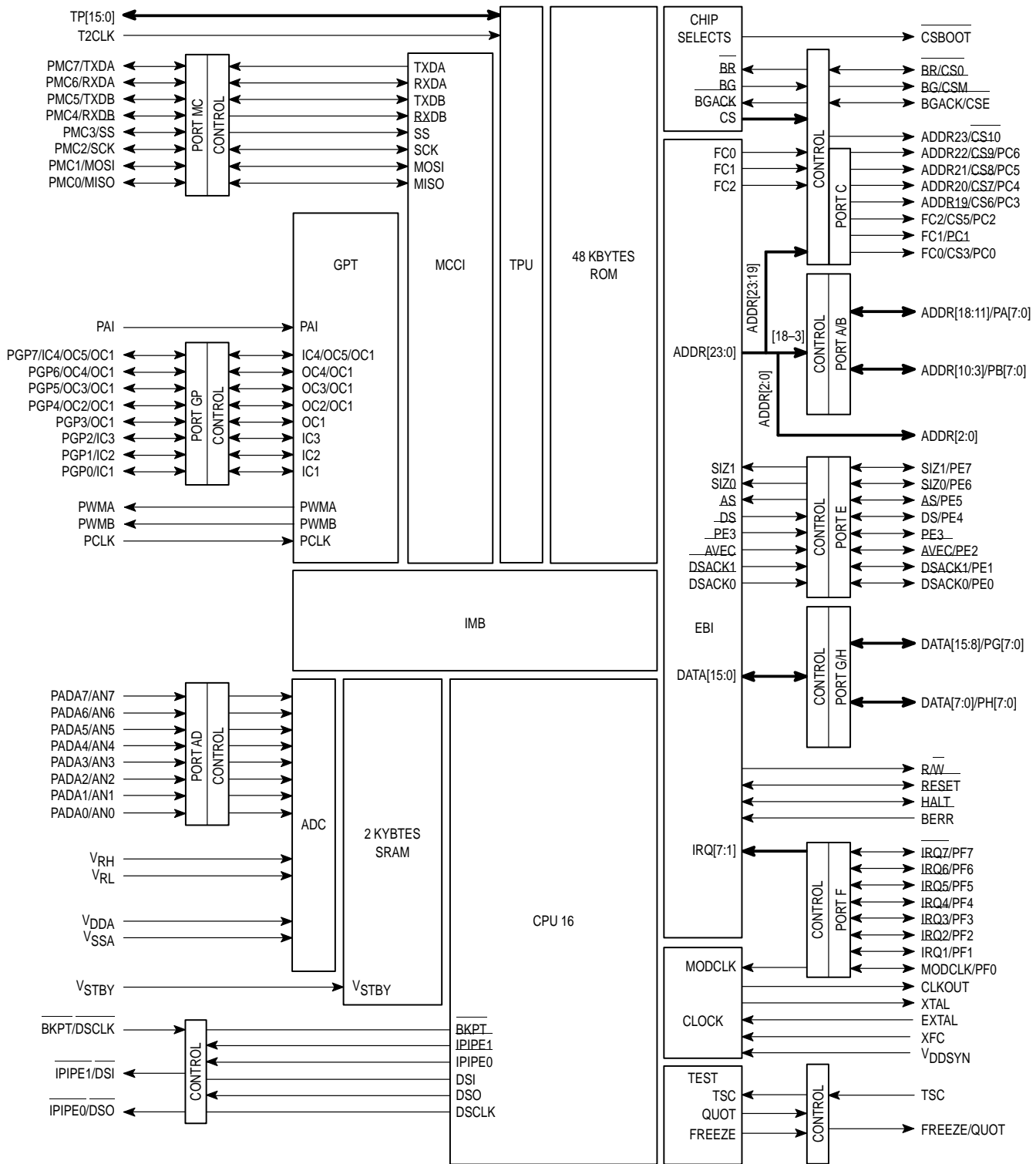

Figure 6. MC68HC16Y1 Block Diagram

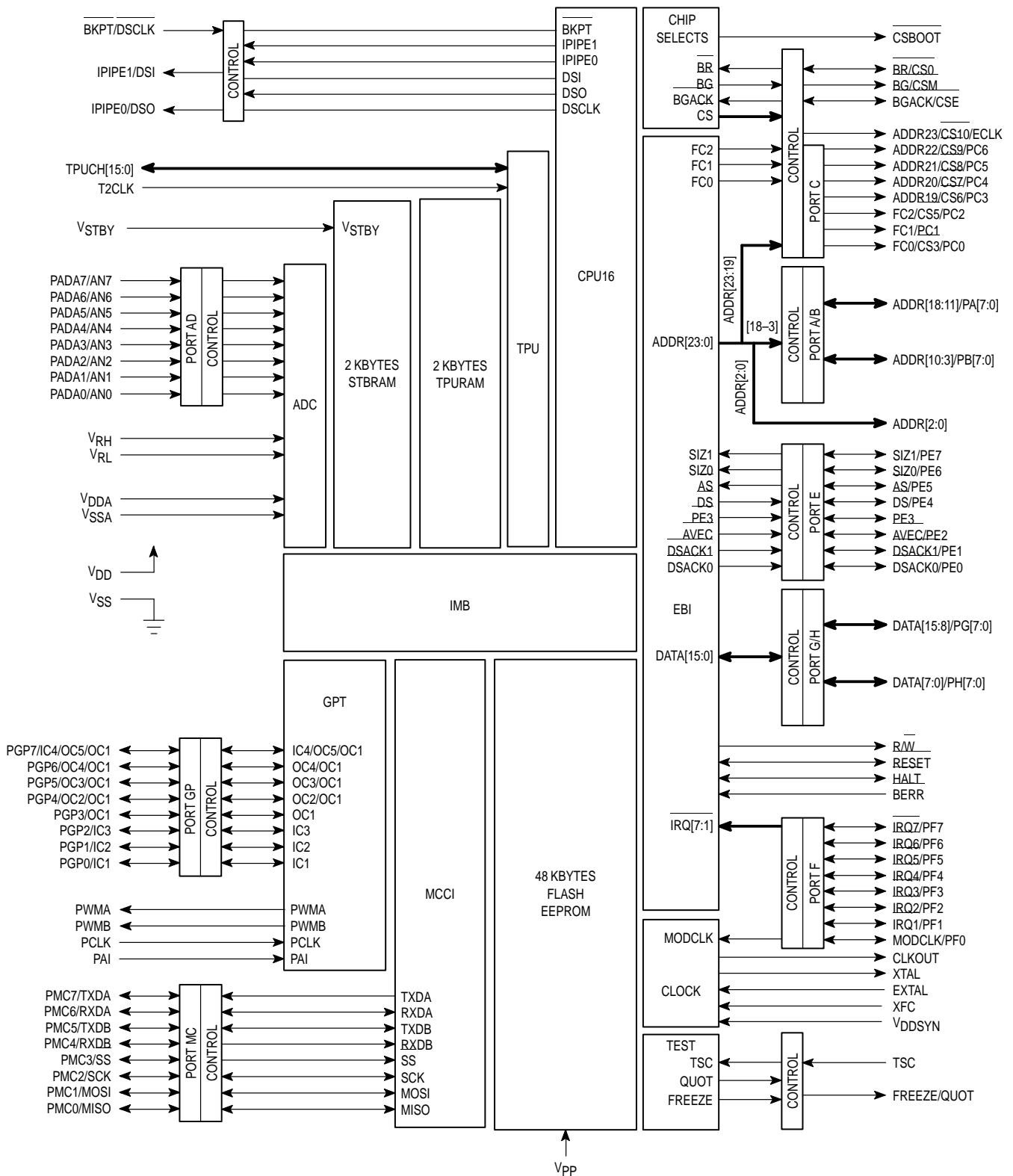

Figure 7. MC68HC916Y1 Block Diagram

Table 7. M68HC16 Family Modular Microcontrollers

Part Number	ROM	SRAM	EEPROM	Timer	I/O	Serial	ADC	Integration Module	Package	Comments
MC68HC16Z1	–	1K	–	GPT	46	QSM	8 Ch, 10–Bit	SIM	132–FC 132–FD 144–FM 144–FV	20 Address Lines, 12 Chip Selects, Synthesized Clock
MC68HC16Z2	8K	2K	–	GPT	46	QSM	8 Ch, 10–Bit	SIM	132–FC 132–FD	20 Address Lines, 12 Chip Selects, Synthesized Clock
MC68HC16Y1	48K	2K	–	TPU + GPT	95	MCCI	8 Ch, 10–Bit	SCIM	160–FT 160–FM	20 Address Lines, 9 Chip Selects, Single Chip or Expanded Mode
XC68HC916X1		1K	2K BEFlash 48K Flash	GPT	70	QSM	8 Ch, 10–Bit	RPSCIM	120–TH	20 Address Lines, 5 Chip Selects, Single Chip or Expanded Mode
XC68HC916Y1	–	4K	48K Flash	TPU + GPT	95	MCCI	8 Ch, 10–Bit	SCIM	160–FT 160–FM	20 Address Lines, 9 Chip Selects, Single Chip or Expanded Mode

The M68300 Family

The high-performance M68300 family is designed for embedded control applications. Each M68300 MCU incorporates a 32-bit M68000-based CPU module (CPU32), a sophisticated integration module, and a number of dedicated special-purpose modules. In addition to utilizing a bus protocol similar to that of the M68020, the system integration module generates external bus-control signals for

M6800 devices, and provides a variety of programmable chip-select functions. M68300 devices can be placed in low-power stop mode to minimize power consumption during periods of inactivity. The M68300 family provides great design flexibility, performance, and compatibility with existing hardware and software.

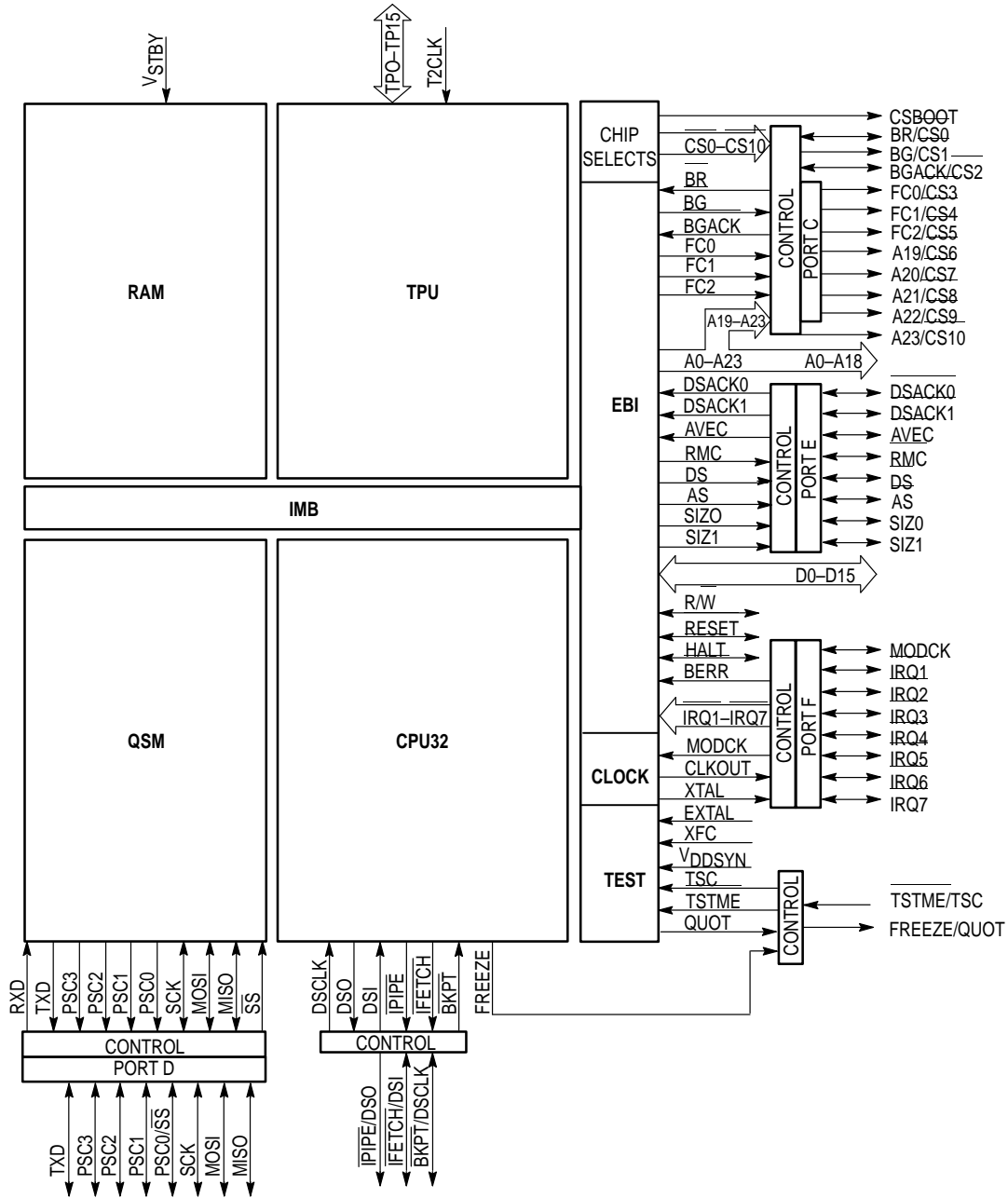

Figure 8. MC68332 Block Diagram

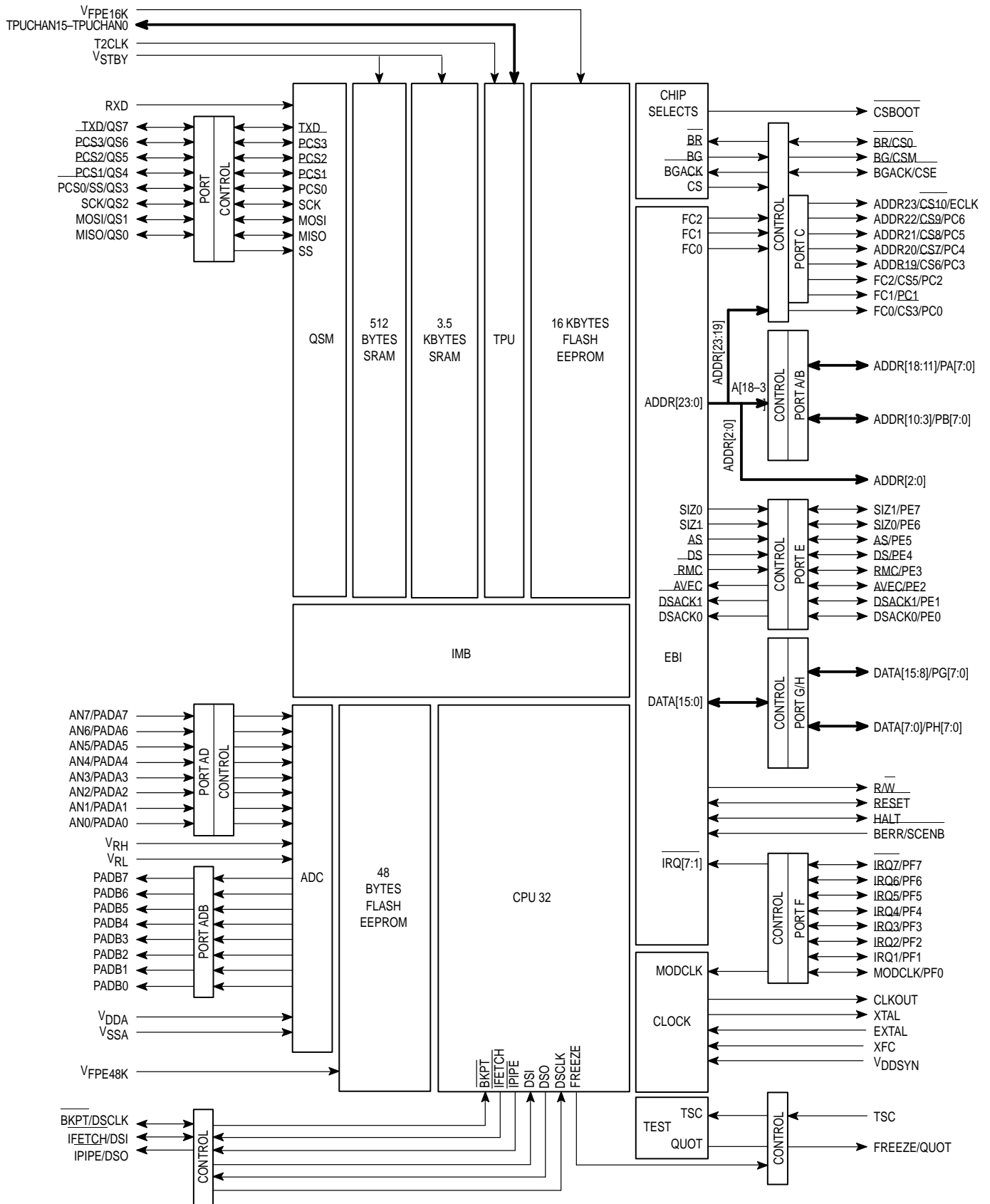

Figure 9. MC68F333 Block Diagram

Table 8. M68300 Family Modular Microcontrollers

Part Number	ROM	SRAM	EEPROM	Timer	I/O	Serial	ADC	Integration Module	Package	Comments
MC68331	–	–	–	GPT	43	QSM	–	SIM	132–FC, 132–FD, 144–FM, 144–FV	12 Chip Selects, Synthesized Clock
MC68332	–	2K	–	TPU	47	QSM	–	SIM	132–FC, 132–FD, 144–FM, 144–FV	12 Chip Selects, Synthesized Clock
PC68F333	–	4K	16K Flash, 48K Flash Emulator	TPU	96	QSM	8 Ch, 10–Bit	SCIM	160–FT, 160–FM	9 Chip Selects, Synthesized Clock
XC68334	–	1K	–	TPU	47	–	8 Ch, 10–Bit	SIM	132–FC, 132–FD	12 Chip Selects, Synthesized Clock, Single Chip or Expanded Mode

Definitions for Tables 9 and 10			
General Definitions		Package Definitions	
ADC	Analog to Digital Converter Module	FB	10x10 mm Quad Flat Pack (QFP)
A/D	Analog to Digital Converter	FC	Fine Pitch Plastic Quad Flat Pack (PQFP)
CPU16	16 bit Central Processing Unit	FD	Plastic Quad Flat Pack in Molded Carrier Ring
CPU32	32 bit Central Processing Unit	FE	Ceramic Quad Flat Pack (CQFP)
D/A	Digital to Analog Converter	FM	Molded Carrier Flat Pack (CQFP)
DMA	Direct Memory Access	FN	Plastic Leaded Chip Carrier (PLCC)
GPT	General–Purpose Timer	FS	Windowed Cerquad (Ceramic LCC)
IC	Input Capture	FT	28x28 mm Quad Flat Pack (QFP)
IIC	Inter–Integrated Circuit	FU	14x14 mm Quad Flat Pack (QFP)
MCCI	Multi–Channel Communication Interface	FV	20x20 mm Quad Flat Pack (QFP)
PLL	Phase Lock Loop	L	Ceramic
OC	Output Capture	P	Dual–in–Line Plastic
POQ	Preferred Order Quantity Multiple	PB	Thin Quad Flat Pack (TQFP) 10x10 mm
PWM	Pulse Width Modulation	PU	Thin Quad Flat Pack (TQFP) 14x14 mm
QSM	Queued Serial Module	PV	Thin Quad Flat Pack (TQFP) 20x20mm
RPSCIM	Reduced Pin Count SCIM	S	Cerdip (windowed or non–windowed)
RTC	Real–Time Clock	TH	16x16 mm Quad Flat Pack (QFP)
RTI	Real–Time Interrupt		
SCI	Serial Communication Interface		
SCIM	Single Chip Integration Module		
SIM	System Integration Module		
SPI	Serial Peripheral Interface		
TPU	Time Processing Unit		
UART	Universal Asynchronous Receiver/Transmitter		
WDOG	Watch Dog Timer		

Microcontroller Development Tools

M68HC05 Family

The M68HC05 Family is supported by a variety of development tools including Evaluation Modules (EVM) and Evaluation Systems (EVS). Both provide an economical means of designing, debugging, and evaluating M68HC05 microcontrollers in a target system environment.

Many new M68HC05 CSIC devices are supported by an MCU-specific EVS. The EVS is a two-board system consisting of a 68HC05 Platform Board (PFB) and an Emulator Module (EM) which contains the emulating microcontroller, and control circuits.

The M68HC05 Family is also supported by the Compact Development System (CDS) for 8-bit microcontrollers (M68CDS8HC05), a powerful, portable, full-featured emulator for debugging hardware and software operations. The CDS8HC05 features high-speed, non-invasive, in-circuit emulation with real-time trace, and a powerful bus state analyzer. Commands are entered from an MS-DOS® host computer.

The Motorola Modular Development System for the M68HC05 Family, MMDS05, allows the use of Emulation Modules (EM) that are compatible with the existing EVS product line. The MMDS05 provides an upgrade for CDS8HC05 customers. The MMDS05 has all of the features of the CDS8HC05, and includes a notable enhancement. A dual-port RAM "memory window" allows a user to modify memory while a program is running at full speed. An internal power supply and totally shielded enclosure assure compliance with FCC and EC92 regulations. The development software provided with the MMDS05 is an enhancement of the EVM05/EVM11 front end — it provides an integrated development environment with true Source Level Debug (SLD).

M68HC11 Family

The M68HC11 Family is supported by a variety of economical development tools. These include Evaluation Boards (EVB), Evaluation Modules (EVM), and Evaluation Systems (EVS).

An EVB allows a user to debug code under the BUFFALO (Bit User Fast Friendly Aid to Logical Operations) monitor/debugging program contained in the microcontroller ROM. The EVB emulates only the single-chip mode of operation and has no EPROM programmer. The EVBU, a "universal" version of the EVB, includes a wire-wrap area for custom interfacing.

EVM are low-cost tools for designing, debugging, and evaluating M68HC11 devices in a target system. An EVM provides essential microcontroller signals and timing, and on-board monitor/debugging firmware contains extensive commands for controlling I/O and debug operations.

An EVS is a two-board system consisting of a 68HC11 Platform Board (PFB) and an Emulator Module (EM). The EM contains control circuits and a 68HC11 MCU for the part or series of parts being emulated. An EVS provides expanded, multiplexed, special test, and single-chip mode emulation, a dual 64 kbyte memory map with 64 kbytes of emulation RAM, and an RS-232 port.

In addition, the Intermetrics Whitesmiths 68HC11 C Compiler/Assembler (M68S11CCAB) and 68HC11 Simulator Debugger (M68S11SIMAB) are now available through Motorola.

Modular Microcontroller Families

In-circuit debuggers for modular microcontroller families (M68ICD32 and M68ICD16) are economical development and debugging environments. ICD make use of the non-intrusive Background Debug Mode (BDM) interface, and provide sophisticated software debugging functions. The ICD consist of debugger and assembler development software, a small interconnect board, and target system cable. The IASM32 and IASM16 assemblers provide a single development environment that includes an editor and cross-assembler programs. ICD source-level debugger software uses easy-to-read screen windows to display register information for the CPU, the instruction pointer, breakpoints, program memory, and data memory.

The MC68331 and MC68332 are supported by evaluation kits (EVK). These multi-board systems include a common platform board, a Business Card Computer (BCC) that contains the MCU being emulated, and the CPU32BUG debug monitor program. The EVK is a cost-effective system for designing, debugging, and evaluating target system software and hardware. The MC68340 is supported by an evaluation system (EVS) similar to the EVK with the addition of a development interface board for a comprehensive development environment.

The M68HC16Z1 Evaluation Board (EVB) is an inexpensive tool for designing, debugging, and evaluating the MC68HC16Z1. Features include background-mode operation, an integrated assembly/editing/emulation environment, and logic analyzer pod connectors.

Modular evaluation boards (MEVB) for each modular family member are under development. The MEVB system is a multi-board evaluation system that consists of a common platform board (PFB) and interchangeable MCU personality boards (MPB). The MEVB system provides an economical development environment for downloading and debugging software generated with IASM16 and IASM32.

Motorola also sells the Intermetrics Whitesmiths 68HC16 C Compiler/Assembler (M68S16CCAB) and 68HC16 Simulator Debugger (M68S16SIMAB) for the M68HC16 Family. In addition, the Intermetrics InterTools™ 683XX C Compiler/Assembler (M68S32CCAB) and 683XX ROM Monitor Debugger (M68S32ROMAB) for the M68300 Family are now available through Motorola.

Table 9. Development Tools

Devices	Evaluation Modules*	Programmer Boards	Evaluation Systems/Kits
M6800 Development Tools			
MC6801		M68701EVM	
MC6801U4		M68701EVM	
MC68701		M68701EVM	
MC68701U4		M68701EVM	
MC6803		M68701EVM	
MC6803U4		M68701EVM	
M68HC05 Development Tools			
MC68HC05B4/B6/B8/B16 MC68HC705B5 MC68HC705B16	M68HC05X16EVS M68HC05X16EVS M68HC05X16EVS	M68HC05BPGMR M68HC05BPGMR	52PLCCU: 52 Pin PLCC Target Cable Use M68HC05X16PGMR for 64 QFP
MC68HC05C5 XC68HC705C5	M68HC05C5EVS M68HC05C5EVS		44 PLCC05M: 44 Pin PLCC Target Cable
MC68HC05C4/C4A/C8/C9/C12 XC68HC05C4 MC68HC705C8 XC68HC705C	M68HC05C9EVS M68HC05C9EVS	M68HC05PGMR-2	44 PLCC05M: 44 Pin PLCC Target Cable
MC68HC05D9/D24 XC68HC05D32 MC68HC705D9	M68HC05D32EVS M68HC05D32EVS	M68HC05PGMR-2	44 PLCC05M: 44 Pin PLCC Target Cable
MC68HC05E1 MC68HC705E1	M68HC05E1EVS M68HC05E1EVS		
XC68HC05F2 XC68HC05F6	M68HC05F6EVM		42 SDIP Target Cable Included
XC68HC05F8 XC68HC705F8	M68HC05F8EVM M68HC05F8EVM	M68HC705F8PGMR	
MC68HC05G1 MC68HC705G1	M68HC05G1EVM M68HC05G1EVM	M68HC705G1PGMR	
XC68HC05G9 XC68HC705G9	M68HC05G9EVM M68HC05G9EVM	M68HC705G9PGMR	
XC68HC05G10 XC68HC705G10	M68HC05G10EVM M68HC05G10EVM		
XC68HC05H2	M68HC05H2EVS		
XC68HC05I8 XC68HC705I8	M68HC05I8EVS M68HC05I8EVS	M68HC705L4PGMR	
MC68HC05J1 MC68HC705J2	M68HC05P8EVS M68HC05P8EVS	M68HC705J2PGMR	
XC68HC05J3 XC68HC705J3	M68HC05J3EVS M68HC05J3EVS	M68HC705J2PGMR	
XC68HC05K0/K1 XC68HC705K1		M68HC705KIGANG** Use M68HC705KICS	M68HC705KICS In-Circuit Simulator M68HC705KICS In-Circuit Simulator

* EVSs and EVMs include an Integrated Development Environment (IDE) which contains an editor, assembler and hardware debugger.

* EVSs and EVMs do not include target cables or OTP/EPROM programming capability unless noted in comment section.

** Development tools that are scheduled for availability during 1Q94.

Table 9. Development Tools (continued)

Devices	Evaluation Modules*	Programmer Boards	Evaluation Systems/Kits
M68HC05 Development Tools (continued)			
XC68HC05L1 XC68HC705L1	M68HC05L1EVM M68HC05L1EVM		56 SDIP Target Cable Included
XC68HC05L2 XC68HC705L2	M68HC05L2EVS M68HC05L2EVS	M68HC705L2PGMR	
XC68HC05L4 XC68HC705L4	M68HC05L4EVS M68HC05L4EVS	M68HC705L4PGMR	M68SDIP64: 64 Pin SDIP Target Cable
MC68HC05L5 MC68HC705L5	M68HC05L5EVS M68HC05L5EVS	M68HC705L5PGMR	80QFPKIT: 80 Pin QFP Target Cable
MC68HC05L7/L9	M68HC05L9EVM2		
MC68HC05L10	M68HC05L10EVM		
XC68HC05L11	M68HC05L11EVM		
XC68HC05M4	M68HC05M4EVM		
XC68HC05P3	M68HC05P3EVS		
MC68HC05P1/P4/P6/P7/P9 XC68HC705P9	M68HC05P9EVS M68HC05P9EVS	M68HC705P9PGMR	XMDS05 Hi-Performance In-Circuit Emulator 68HC705P6 is required for P6 EVS Capability
MC68HC05P8	M68HC05P8EVS		
XC68HC05SC11/SC21/SC24/SC27	M68HC05SCEVS		ISO Adaptor Included with M68HC05SCEVS
MC68HC05T1 XC68HC05T2/T3	M68HC05T2EVS		
XC68HC05T4	M68HC05T4EVM		
MC68HC05T7/T10 XC68HC705T10	M68HC05T7EVM M68HC05T7EVM	M68HC705T10PGMR	
XC68HC05T12 XC68HC705T12	M68HC05T12EVM M68HC05T12EVM	M68HC705T12PGMR	
XC68HC05X4 XC68HC705X4	M68HC05X4EVS M68HC05X4EVS	M68HC705X4PGMR	
XC68HC05X16 MC68HC705X16	M68HC05X16EVS M68HC05X16EVS	M68HC705X16PGMR	68 PLCCU: 68 Pin PLCC Target Cable
M68HC11 Development Tools			
MC68HC11A0/A1/A8	M68HC11EVB M68HC11EVB2 M68HC11EVBU	M68HC11EVM	
MC68HC11D0/D3		M68HC11EVM	M68HC11D3EVS
MC68HC711D3	M68HC711D3EVB	M68HC11EVM	M68HC11D3EVS
MC68HC11E0/E1/E2/E9	M68HC11EVB M68HC11EVBU	M68HC11EVM	
MC68HC711E9	M68HC11EVBU	M68HC11EVM	
MC68HC811A8/E2	M68HC11EVB M68HC11EVBU	M68HC11EVM	

* EVSs and EVMs include an Integrated Development Environment (IDE) which contains an editor, assembler and hardware debugger.

* EVSs and EVMs do not include target cables or OTP/EPROM programming capability unless noted in comment section.

** Development tools that are scheduled for availability during 1Q94.

Table 9. Development Tools (continued)

Devices	Evaluation Modules*	Programmer Boards	Evaluation Systems/Kits
M68HC11 Development Tools (continued)			
MC68HC11F1			M68HC11F1EVS
MC68HC11G5/G7 MC68HC711G5			M68HC11G7EVS
MC68HC11KA4			M68HC11KA4EVS
MC68HC11K0/K1/K4 MC68HC711K4			M68HC11K4EVS
MC68HC11L0/L1/L6 MC68HC711L6			M68HC11L6EVS
MC68HC11M2 MC68HC711M2			M68HC11KMNPEVS
MC68HC11N4 MC68HC711N4			M68HC11KMNPEVS
MC68HC11P2 MC68HC711P2			M68HC11KMNPEVS
M68HC16 Development Tools			
MC68HC16Y1	MG8MEVB16Y1		
MC68HC16Z1	M68MEVB16Z1		
MC68HC16Z2	M68MEVB16Z1		
M68300 Development Tools			
MC68331	M68MEVB333		M68331EVK
MC68332	M68MEVB16Z1		M68332EVS/M68332EVK
MC68F333 MC6805R2/R3	M68MEVB333		

* EVSs and EVMs include an Integrated Development Environment (IDE) which contains an editor, assembler and hardware debugger.

* EVSs and EVMs do not include target cables or OTP/EPROM programming capability unless noted in comment section.

** Development tools that are scheduled for availability during 1Q94.

Fuzzy Logic

Fuzzy logic replaces conventional programming techniques with a simpler approach to control algorithms. Fuzzy logic uses a series of case statements to create sophisticated features that do not require additional memory or excessive processing time.

Motorola's portfolio of fuzzy logic products is geared for every level of user. The fuzzy logic educational kit (part number FLEDKT00) includes everything needed to learn how to use fuzzy logic with M68HC05 and M68HC11 microcontrollers.

- An easy-to-follow PC-based tutorial
 - Explains fuzzy logic fundamentals, basic concepts and terminology
 - Methodology section teaches a five-step sequence of principles and procedures for designing a fuzzy logic system. These include defining the control system, writing rules and membership functions, tuning and debugging and optimizing the design.
 - Advanced topics section covers areas such as stability, adaptability, ambiguity, noise, alpha-cuts and contribution weights
- A Knowledge Base Generator (KBG)
 - Uses natural language inputs to generate a knowledge base (rules and membership functions)
 - Inference Engines for the M68HC11 and M68HC05 families implement the fuzzy logic in software ready to embed in your Motorola microcontroller application

- Runs a software simulation of the inference engine and displays a two-dimensional plot of the control surface
- Generates real-time code for the standard M68HC05 or M68HC11 microcontroller families which can be downloaded to an evaluation module (EVM) for in-circuit emulation
- Demonstration-version of Apronix's Fuzzy Inference Development Environment (FIDE) software
 - Features powerful, time-saving debug functions to help determine the correct membership functions and rules for any application
 - Demonstrates easy-to-use graphical interface for designing and debugging integrated systems

Apronix's Fuzzy Inference Development Environment (FIDE™) is a powerful software tool that allows users to easily edit, simulate, debug, and tune the membership functions and rules of a fuzzy logic application. FIDE offers graphical and natural language editing of source files. The user-friendly debug tools allow time domain simulations, three-dimensional surface displays of input-to-output relationships, and linkage of fuzzy and non-fuzzy modules. FIDE also generates assembler code that implements fuzzy logic on Motorola microcontrollers.

On-Line Help

Microcontroller Electronic Bulletin Board

Freeware Data Service provides a direct line to the latest information and software for Motorola microcontrollers. The Freeware bulletin board provides access to:

- Development Software for PC and Macintosh Computers
 - Cross Assemblers
 - Small C Compiler for 68HC11
 - EVM and EVB Monitor/Debugger Object Code
- Development software
 - Floating Point Routines
 - Fast Fourier Transform Routines
 - 16-Bit Math Packages
 - Utility Programs
 - User Group Library Routines and User-Donated Programs
- Kermit File Transfer Program
- Terminal Emulation Program
- Masked ROM information
- MCU literature listings
- Updates/Erratas to existing literature

- Press releases and updates concerning new and phase-out products
- Contests, promotions and seminars
- Electronic mail service

How to Access Freeware

You can access Freeware from anywhere in the world. To log on, you'll need the following equipment:

1. 2400/1200/300 baud modem
2. Terminal, MS-DOS personal computer or Macintosh computer
3. Telephone line

This equipment will allow the user to read files and post questions. However, with a file transfer program such as XMODEM, YMODEM or Kermit, all information can be downloaded to your terminal or PC.

To log on:

1. Dial (512) 891-FREE (891-3733). Be sure to set the character format to 8 data, no parity, 1 stop bit.
2. Follow directions from the system.
3. Read log-on messages, then follow the directions on the screen display. A log-on session is limited to 120 minutes.

Third-Party Support

Development support for Motorola microcontrollers is available from a variety of independent suppliers.

Third-Party Development Tools

Table 10. Software Products

M68HC05 Family	M68HC11 Family	M68HC16 Family	M68300 Family
Simulators			
Byte Craft Ltd. P&E Microcomputer Systems, Inc. PseudoCorp. TECi	Avocet Systems, Inc. Nohau Corp. P&E Microcomputer Systems, Inc.	P&E Microcomputer Systems, Inc.	Software Environments Ltd.
Assemblers			
2500AD Software, Inc. American Arium Byte Craft Ltd. Computer Systems Consultants, Inc. Eris Systems, Inc. Introl Corp. Lloyd I/O, Inc. LOGISOFT Micro Dialects, Inc. Onset Computer Corp. P&E Microcomputer Systems, Inc. PseudoCorp. TECi	2500AD Software, Inc. Archimedes Software, Inc. Avocet Systems, Inc. Computer Systems Consultants, Inc. Eris Systems, Inc. Introl Corp. Lloyd I/O, Inc. LOGISOFT Micro Dialects, Inc.	2500AD Software, Inc. Byte Craft Ltd. Eris Systems, Inc. Introl Corp. Micro Dialects, Inc. P&E Microcomputer Systems, Inc.	Avocet Systems, Inc. Eyring Systems Software Division Introl Corp. Micro Dialects, Inc. Microtec Research, Inc. Oasys, Inc.
Symbolic Debuggers			
2500AD Software, Inc. Byte Craft Ltd. P&E Microcomputer Systems, Inc. TECi Wytec Company	2500AD Software, Inc. Microtec Research, Inc. P&E Microcomputer Systems, Inc. TECi	Byte Craft Ltd.	Eyring Systems Software Division Integrated Systems, Inc. JMI Software Consultants, Inc.
Compilers			
American Arium Byte Craft Ltd.	2500AD Software, Inc. Archimedes Software, Inc. Avocet Systems, Inc. Forth, Inc. Intermetrics Microsystems Software, Inc. Introl Corp. Laboratory Microsystems Inc. New Micros, Inc. Software Environments Ltd. SYNGEN Industrial Control	Byte Craft Ltd. Intermetrics Microsystems Software, Inc. Introl Corp. Software Environments Ltd.	Eyring Systems Software Division Forth, Inc. Integrated Systems, Inc. Intermetrics Microsystems Software, Inc. Introl Corp. Laboratory Microsystems Inc. Microtec Research, Inc. Microware Systems Corp. RAVEN Computer Systems Sierra Systems

Table 10. Software Products (continued)

M68HC05 Family	M68HC11 Family	M68HC16 Family	M68300 Family
Source Level Debuggers			
Byte Craft Ltd. Yokogawa Digital Computer Corp. Introl Corp.	Huntsville Microsystems, Inc. Intermetrics Microsystems Software, Inc. Introl Corp. Yokogawa Digital Computer Corp.	Huntsville Microsystems, Inc. Intermetrics Microsystems Software, Inc. Introl Corp. Yokogawa Digital Computer Corp.	Embedded Support Tools Corp. Eyring Systems Software Division GreenSpring Computers, Inc. Huntsville Microsystems, Inc. Integrated Systems, Inc. Intermetrics Microsystems Software, Inc. Microtec Research, Inc. Sierra Systems Yokogawa Digital Computer Corp.
Real-Time Executives			
	Accelerated Technology, Inc. A. T. Barrett & Associates U S Software Corporation	A. T. Barrett & Associates U S Software Corporation	Accelerated Technology, Inc. A. T. Barrett & Associates Eyring Systems Software Division GreenSpring Computers, Inc. Integrated Systems, Inc. JMI Software Consultants, Inc. Microware Systems Corp. Ready Systems U S Software Corporation
Other			
PsuedoCorp	Logic Automation Inc. LOGISOFT PsuedoCorp U S Software Corporation	Momentum Data Systems, Inc. U S Software Corporation	Avocet Systems, Inc. CARDtools Systems Corp. Eyring Systems Software Division GreenSpring Computers, Inc. Integrated Systems, Inc. JMI Software Consultants, Inc. Logic Automation Inc. Microware Systems Corp. U S Software Corporation

Table 11. Hardware Products

M68HC05 Family	M68HC11 Family	M68HC16 Family	M68300 Family
Logic Analyzers			
	American Arium Hewlett–Packard Step Engineering Tektronix, Inc.	Hewlett–Packard Tektronix, Inc.	Hewlett–Packard
Emulators			
American Arium Orion Instruments, Inc. Pentica Systems Inc. Sophia Systems & Technology TECi Thorson Engineering Co. Trace Technology Ltd. Yokogawa Digital Computer Corp.	Advance Electronic Diagnostics, Inc. American Arium Huntsville Microsystems, Inc. MetaLink Corp. Nohau Corp. Orion Instruments, Inc. Pentica Systems Inc. Sophia Systems & Technology TECi Thorson Engineering Co. Wytec Company Yokogawa Digital Computer Corp.	Embedded Support Tools Corp. Huntsville Microsystems, Inc. Nohau Corp. Pentica Systems, Inc. Yokogawa Digital Computer Corp.	Advance Electronic Diagnostics, Inc. Applied Microsystems Embedded Support Tools Corp. Hewlett–Packard Huntsville Microsystems, Inc. Microtek International Nohau Corp. Pentica Systems Inc. Yokogawa Digital Computer Corp.
Evaluation Boards			
Elan Digital Systems	Elan Digital Systems Mosaic Industries, Inc. New Micros, Inc.	New Micros, Inc.	GreenSpring Computers, Inc. New Micros, Inc.
Other			
3M Electronic Products Division AMP Inc. EE Tools Co. Elan Digital Systems Pentica Systems Inc. TECi	3M Electronic Products Division AMP Inc. Elan Digital Systems Emulation Technology, Inc. Pentica Systems Inc. SYNGEN Industrial Control	AMP Inc. P&E Microcomputer Systems, Inc.	Emulation Technology, Inc Pentica Systems Inc.

Table 12. Contact List

Company	Phone
3M Electronic Products Division	(512) 984-3441
2500AD Software, Inc.	(719) 395-8683
A. T. Barrett & Associates	(713) 728-9688
Accelerated Technology, Inc.	(205) 450-0707
Advance Electronic Diagnostics, Inc.	(602) 861-9359
American Arium	(714) 731-1661
AMP Inc.	(800) 52AMP52
Applied Microsystems	(800) 426-3925
Archimedes Software, Inc.	(415) 567-4010
Avocet Systems, Inc.	(800) 448-8500
Byte Craft Ltd.	(519) 888-6911
CARDtools Systems Corp.	(408) 559-4240
Computer Systems Consultants, Inc	(404) 483-4570
EE Tools Co.	(716) 346-6973
Elan Digital Systems	(4489) 579799
Embedded Support Tools Corp.	(617) 828-5588
Emulation Technology, Inc.	(408) 982-0660
Eris Systems, Inc.	(612) 374-2967
Eyring Systems Software Division	(801) 375-2434
Forth, Inc.	(213) 372-8493
GreenSpring Computers, Inc.	(415) 327-1200
Hewlett-Packard	(800) 447-3282
Huntsville Microsystems, Inc.	(205) 881-6005
Integrated Systems, Inc.	(408) 980-1500
Intermetrics Microsystems Software, Inc.	(617) 661-0072
Introl Corp.	(414) 327-7171
JMI Software Consultants, Inc.	(215) 628-0840
Laboratory Microsystems Inc.	(310) 306-7412
Lloyd I/O, Inc.	(503) 222-0702
Logic Automation Inc.	(503) 690-6900
LOGISOFT	(408) 773-8465
MetaLink Corp.	(602) 926-0797
Micro Dialects, Inc.	(513) 271-9100
Microtec Research, Inc.	(408) 980-1300
Microtek International	(503) 645-7333
Microware Systems Corp.	(515) 224-1929
Momentum Data Systems, Inc.	(714) 577-6894
Mosaic Industries, Inc.	(415) 790-1255
New Micros, Inc.	(214) 339-2204
Nohau Corp.	(408) 866-1820
Oasys, Inc.	(617) 862-2002

Table 12. Contact List (continued)

Company	Phone
Onset Computer Corp.	(508) 563-9000
Orion Instruments, Inc.	(800) 729-7700
P&E Microcomputer Systems, Inc.	(617) 944-7585
Pentica Systems Inc.	(617) 275-4419
PseudoCorp.	(804) 873-1947
RAVEN Computer Systems	(612) 636-0365
Ready Systems	(800) 228-1249
Sierra Systems	(510) 339-8200
Software Environments Ltd.	(714) 588-9685
Sophia Systems & Technology	(800) 824-9294
Step Engineering	(408) 733-7837
SYNGEN Industrial Control	(403) 986-1203
TECi	(802) 525-3458
Tektronix, Inc.	(503) 629-1773
Thorson Engineering Co.	(206) 334-4214
Trace Technology Ltd.	0234 266 455
U S Software Corporation	(503) 641-8446
Wytec Company	(708) 894-1440
Yokogawa Digital Computer Corp.	(415) 570-7050