



v00.0503

# HMC491LP3

## GaAs MMIC LOW NOISE AMPLIFIER w/ BYPASS MODE, 3.4 - 3.8 GHz

### Typical Applications

The HMC491LP3 is ideal for:

- Wireless Local Loop (WLL)
- Fixed Wireless Access
- Microwave & VSAT Radios

### Features

- Gain: 16 dB
- Noise Figure: 2.0 dB
- Single Supply: +3.0 V @ 9 mA
- Integrated Bypass Mode
- 50 Ohm Matched Input/Output
- 3 x 3 x 1 mm QFN SMT Package

### Functional Diagram

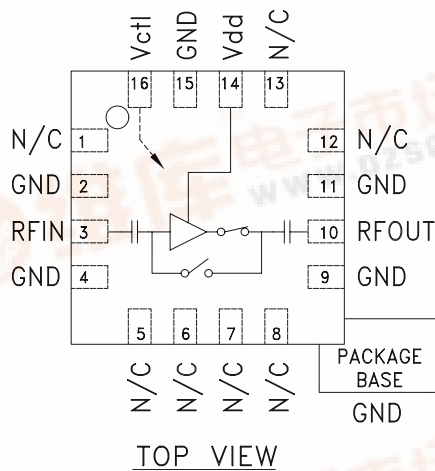

### General Description

The HMC491LP3 is a versatile, integrated, Low Noise Amplifier (LNA) featuring a bypass mode intended for 3.4 to 3.8 GHz Fixed Wireless & WLL applications. The amplifier provides 16 dB of gain, 2 dB noise figure and +3 dBm input IP3 while requiring only 9 mA from a +3V supply. Using a single control line, the LNA can be switched into a low loss 2.2 dB bypass mode reducing the current consumption to 20  $\mu$ A. A low cost, leadless 3x3 mm QFN surface mount package (LP3) houses the amplifier. No external RF matching components are required.

### Electrical Specifications, $T_A = +25^\circ C, V_{dd} = +3V$

Parameter	LNA Mode			LNA Mode			Bypass Mode			Units
	Min.	Typ.	Max.	Min.	Typ.	Max.	Min.	Typ.	Max.	
Frequency Range	3.4 - 3.6			3.6 - 3.8			3.4 - 3.8			MHz
Gain	14.5	17		13	15.5		-2.8	-2.3		dB
Gain Variation Over Temperature		0.012	0.02		0.012	0.02		0.004	0.008	dB / $^\circ C$
Noise Figure		2.2	2.7		2.0	2.5		--	--	dB
Input Return Loss		12			17			18		dB
Output Return Loss		9			7			11		dB
Reverse Isolation		34			33			--		dB
Input or Output Power for 1dB Compression (P1dB)*	3	6		4	7		25	28		dBm
Input Third Order Intercept (IP3) (-20 dBm Input Power per tone, 1 MHz tone spacing)		1			3			11		dBm
Supply Current (I <sub>dd</sub> )		9			9			0.03		mA

\* P1dB for LNA Mode is referenced to RFOUT while P1dB for Bypass Mode is referenced to RFIN.



## GaAs MMIC LOW NOISE AMPLIFIER w/ BYPASS MODE, 3.4 - 3.8 GHz

**LNA Mode**  
**Broadband Gain & Return Loss**

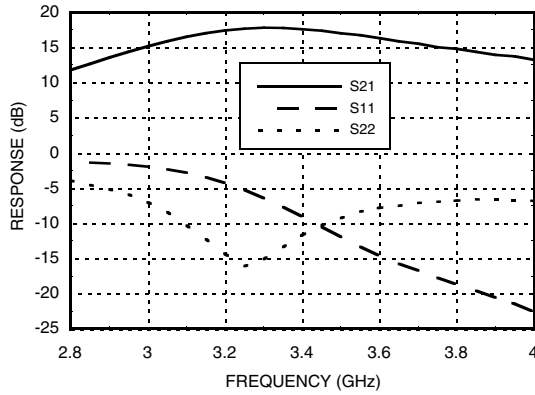

**LNA Mode**  
**Gain vs. Temperature**

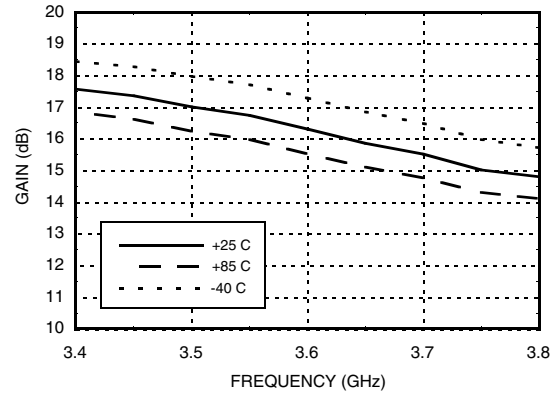

**LNA Mode**  
**Input Return Loss vs. Temperature**

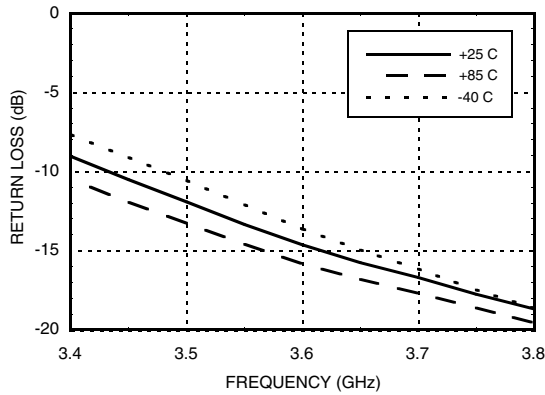

**LNA Mode**  
**Output Return Loss vs. Temperature**

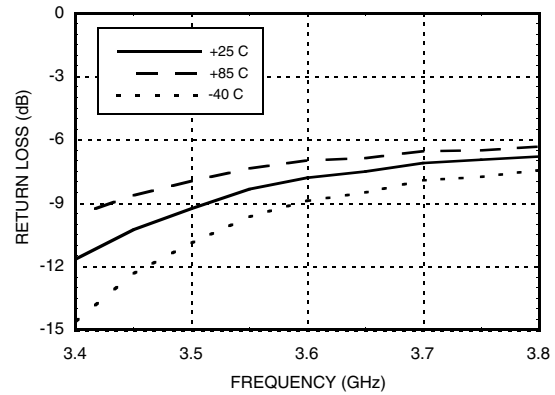

**LNA Mode**  
**Noise Figure vs. Temperature**

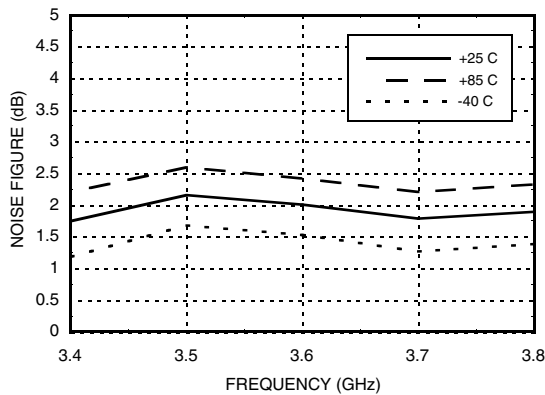

**LNA Mode**  
**Reverse Isolation vs. Temperature**

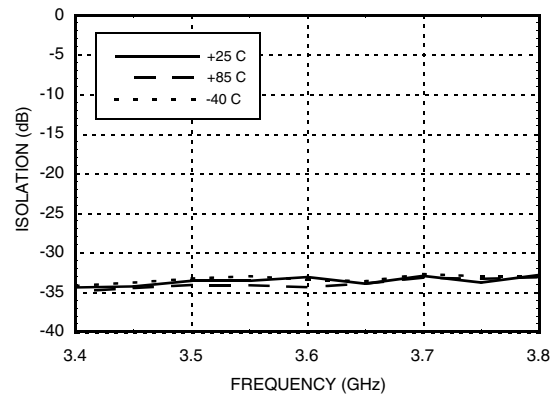

## GaAs MMIC LOW NOISE AMPLIFIER w/ BYPASS MODE, 3.4 - 3.8 GHz

**LNA Mode**  
**Output P1dB vs. Temperature**

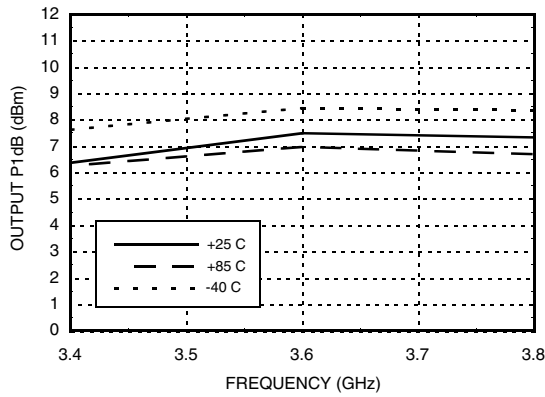

**LNA Mode**  
**Psat vs. Temperature**

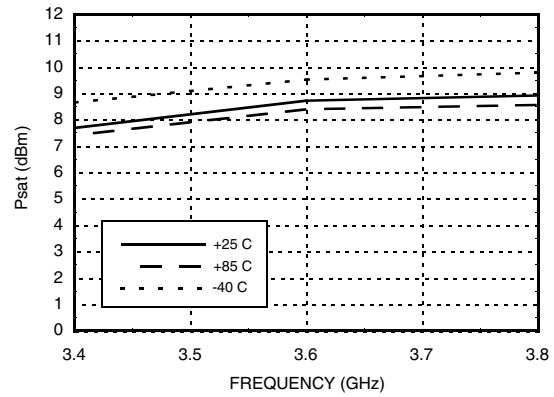

**LNA Mode**  
**Input IP3 vs. Temperature**

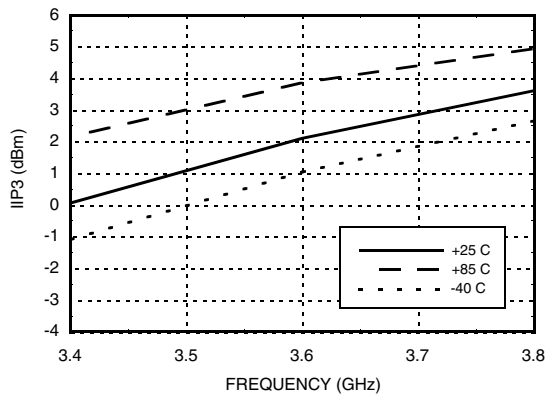

**LNA Mode Gain, Noise Figure & Supply Current vs. Supply Voltage @ 3.6 GHz**

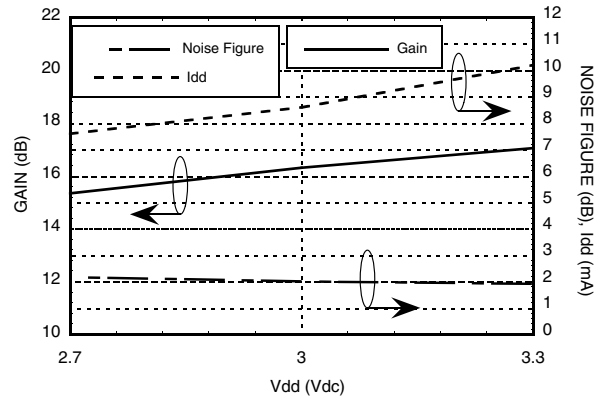

## GaAs MMIC LOW NOISE AMPLIFIER w/ BYPASS MODE, 3.4 - 3.8 GHz

**Bypass Mode**  
**Broadband Insertion Loss & Return Loss**

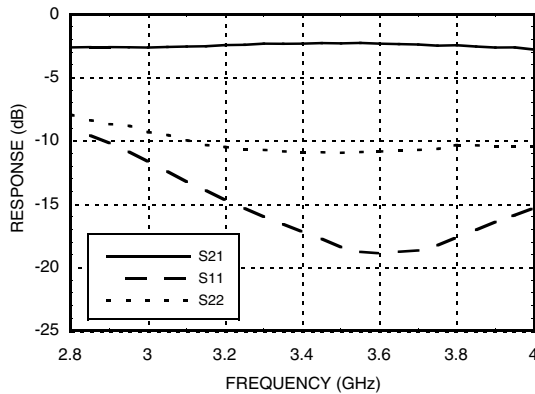

**Bypass Mode**  
**Insertion Loss vs. Temperature**

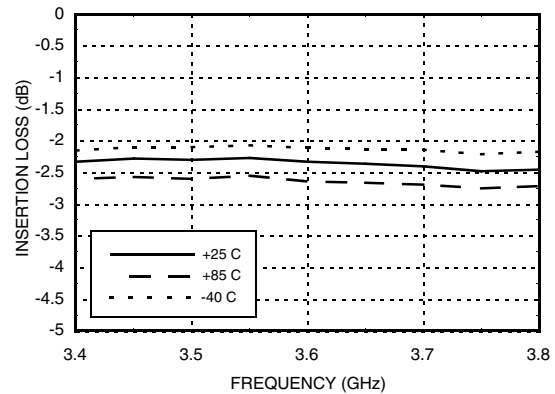

**Bypass Mode**  
**Input Return Loss vs. Temperature**

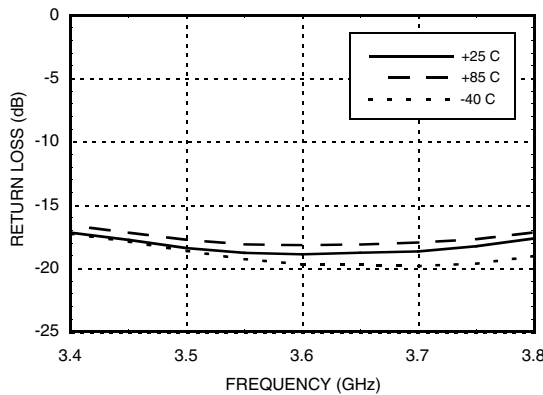

**Bypass Mode**  
**Output Return Loss vs. Temperature**

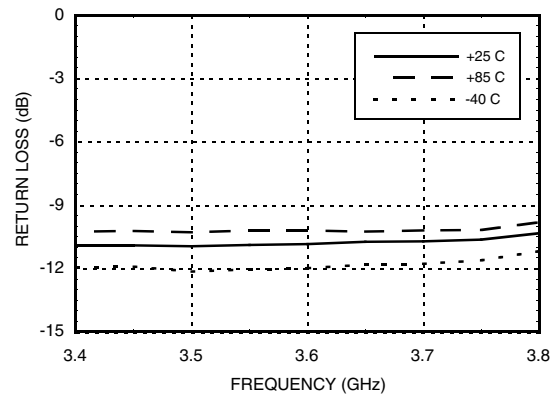

**Bypass Mode**  
**Input IP3 vs. Temperature**

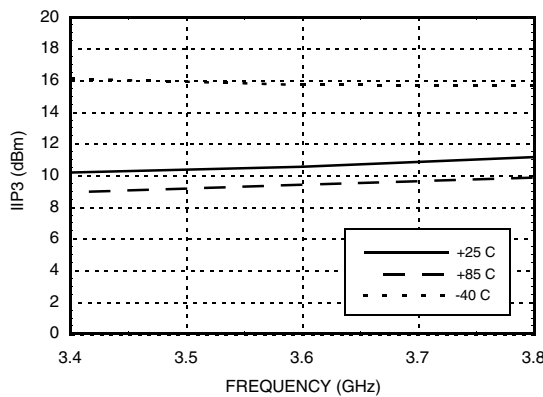

**Bypass Mode**  
**Input P1dB vs. Temperature**

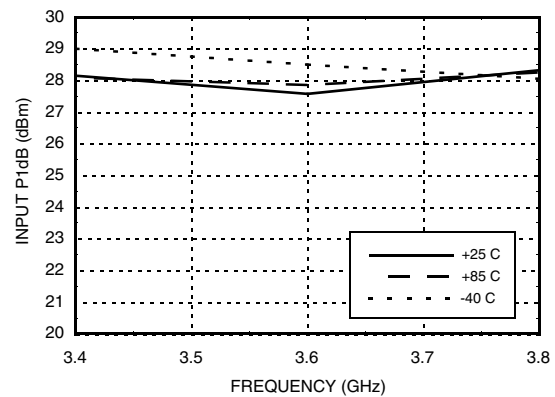

## GaAs MMIC LOW NOISE AMPLIFIER w/ BYPASS MODE, 3.4 - 3.8 GHz

### Absolute Maximum Ratings

Drain Bias Voltage (Vdd)	+7.0 Vdc
RF Input Power (RFIn) (Vdd = +3.0 Vdc)	LNA Mode: 0 dBm Bypass Mode: +30 dBm
Channel Temperature	150 °C
Continuous Pdiss (T = 85 °C) (derate 1.8 mW/°C above 85 °C)	0.117 W
Thermal Resistance (channel to ground paddle)	556 °C/W
Storage Temperature	-65 to +150 °C
Operating Temperature	-40 to +85 °C

### Typical Supply Current vs. Vdd

Vdd (Vdc)	Idd (mA)
+2.7	7.6
+3.0	9.0
+3.3	10.2

### Truth Table

Mode	Vctl
LNA Mode	Vctl= Vdd @ 1.6 mA
Bypass Mode	Vctl= 0Vdc @ -13 µA

Vdd= +3V ±10%

### Outline Drawing

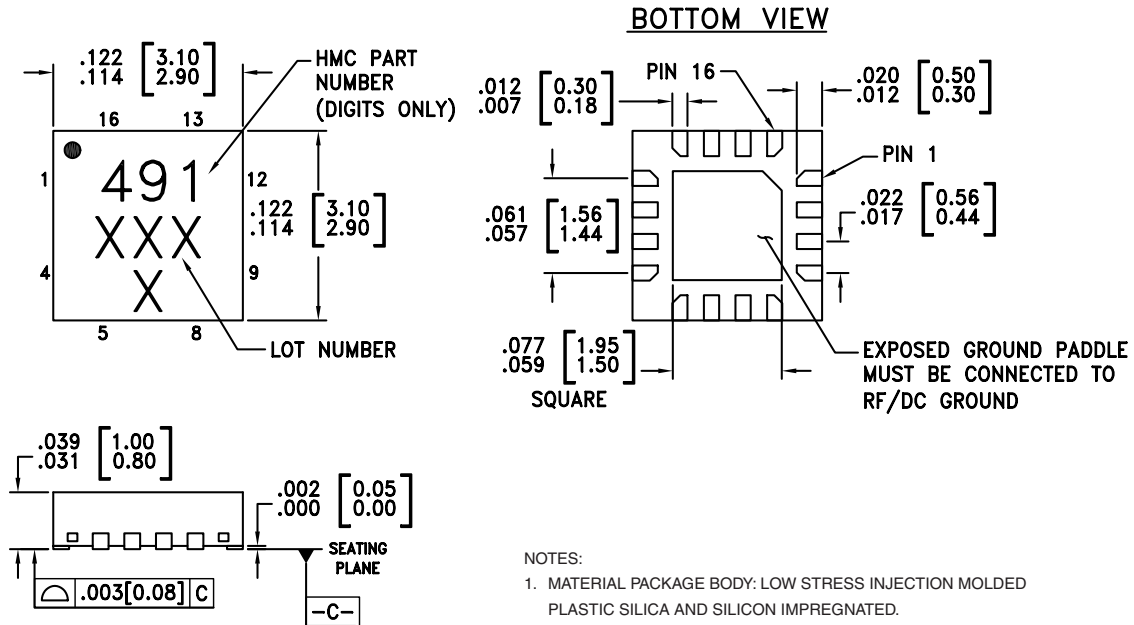

## GaAs MMIC LOW NOISE AMPLIFIER w/ BYPASS MODE, 3.4 - 3.8 GHz

### Pin Descriptions

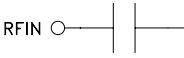
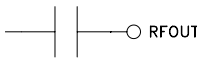
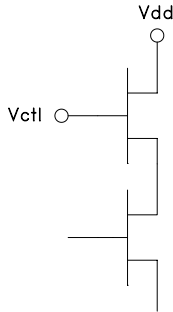
Pin Number	Function	Description	Interface Schematic
1, 5 - 8, 12, 13	N/C	No connection necessary. These pins may be connected to RF/DC ground.	
2, 4, 9, 11, 15	GND	These pins must be connected to RF/DC ground.	
3	RF IN	This pin is AC coupled and matched to 50 Ohms.	
10	RF OUT	This pin is AC coupled and matched to 50 Ohms.	
14	Vdd	Power supply voltage.	
16	Vctl	Control voltage. Vctl= Vdd for LNA mode. Vctl= 0V for bypass mode.	

## GaAs MMIC LOW NOISE AMPLIFIER w/ BYPASS MODE, 3.4 - 3.8 GHz

### Evaluation PCB

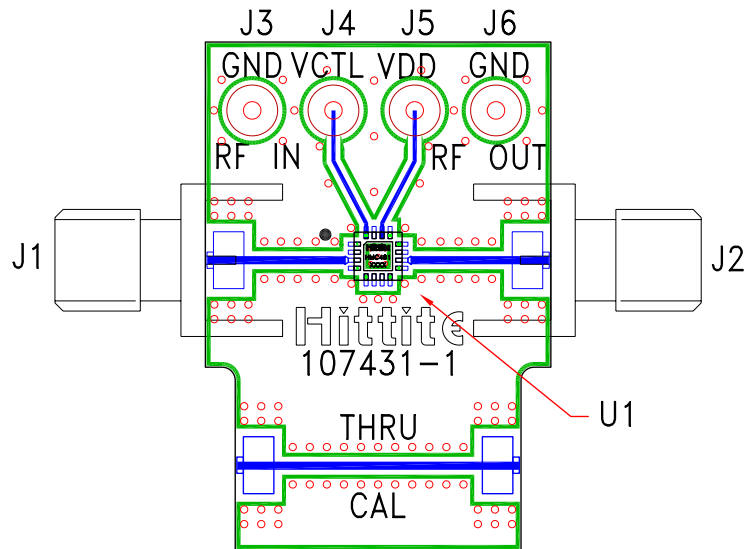

### List of Material

Item	Description
J1 - J2	PC Mount SMA RF Connector
J3 - J6	DC Pin
U1	HMC491LP3 Amplifier
PCB*	107431 Eval Board
* Circuit Board Material: Rogers 4350	

The circuit board used in the final application should use RF circuit design techniques. Signal lines should have 50 ohm impedance while the package ground leads and exposed paddle should be connected directly to the ground plane similar to that shown. A sufficient number of VIA holes should be used to connect the top and bottom ground planes. The evaluation circuit board shown is available from Hittite upon request.



v00.0503

## HMC491LP3

***GaAs MMIC LOW NOISE AMPLIFIER  
w/ BYPASS MODE, 3.4 - 3.8 GHz***

***Notes:***

8

AMPLIFIERS - SMT