

Fuji Discrete Package IGBT

Outline Drawing

Features

- Square RBSOA
- Low Saturation Voltage
- Less Total Power Dissipation
- Minimized Internal Stray Inductance

Applications

- High Power Switching
- A.C. Motor Controls
- D.C. Motor Controls
- Uninterruptible Power Supply

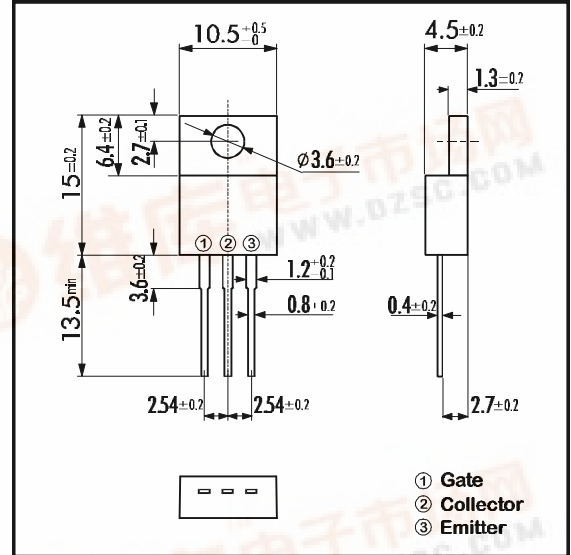

Maximum Ratings and Characteristics

Equivalent Circuit

Absolute Maximum Ratings (T_c=25°C)

Items	Symbols	Ratings	Units
Collector-Emitter Voltage	V _{CES}	600	V
Gate -Emitter Voltage	V _{GES}	± 20	V
Collector Current	DC T _c = 25°C	I _{C 25}	13
	DC T _c =100°C	I _{C 100}	5
	1ms T _c = 25°C	I _{C PULSE}	52
IGBT Max. Power Dissipation	P _C	50	W
Operating Temperature	T _j	+150	°C
Storage Temperature	T _{stg}	-40 ~ +125	°C
Mounting Screw Torque		40	Nm

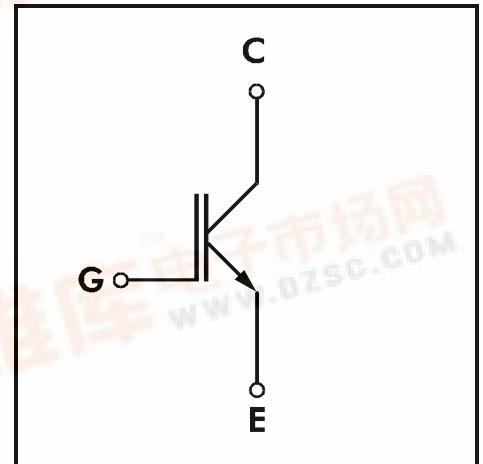

Electrical Characteristics (at T_j=25°C)

Items	Symbols	Test Conditions	Min.	Typ.	Max.	Units		
Zero Gate Voltage Collector Current	I _{CES}	V _{GE} =0V V _{CE} =600V			1.0	mA		
Gate-Emitter Leakage Current	I _{GES}	V _{CE} =0V V _{GE} =± 20V			20	µA		
Gate-Emitter Threshold Voltage	V _{GE(th)}	V _{GE} =20V I _C =5mA	5.5		8.5	V		
Collector-Emitter Saturation Voltage	V _{CE(sat)}	V _{GE} =15V I _C =5A			3.0	V		
Input capacitance	C _{ies}	V _{GE} =0V		400		pF		
Output capacitance	C _{oes}	V _{CE} =10V		85				
Reverse Transfer capacitance	C _{res}	f=1MHz		15				
Switching Time	Turn-on Time	t _{ON}	V _{CC} =300V			1.2	µs	
		t _r	I _C =5A			0.6		
	Turn-off Time	t _{OFF}	V _{GE} =±15V			1.0		
		t _f	R _G =330Ω			0.35		
	Switching Time	Turn-on Time	t _{ON}	V _{CC} =300V		0.16		µs
			t _r	I _C =5A		0.11		
Turn-off Time		t _{OFF}	V _{GE} =+15V		0.30			
		t _f	R _G =33Ω		0.35			

Thermal Characteristics

Items	Symbols	Test Conditions	Min.	Typ.	Max.	Units
Thermal Resistance	R _{th(j-c)}				2.50	°C/W



