



May 2005

# LM3501

## Synchronous Step-up DC/DC Converter for White LED Applications

### General Description

The LM3501 is a fixed-frequency step-up DC/DC converter that is ideal for driving white LEDs for display backlighting and other lighting functions. With fully intergrated synchronous switching (no external schottky diode required) and a low feedback voltage (515 mV), power efficiency of the LM3501 circuit has been optimized for lighting applications in wireless phones and other portable products (single cell Li-Ion or 3-cell NiMH battery supplies). The LM3501 operates with a fixed 1 MHz switching frequency. When used with ceramic input and output capacitors, the LM3501 provides a small, low-noise, low-cost solution.

Two LM3501 options are available with different output voltage capabilities. The LM3501-21 has a maximum output voltage of 21V and is typically suited for driving 4 or 5 white LEDs in series. The LM3501-16 has a maximum output voltage of 16V and is typically suited for driving 3 or 4 white LEDs in series (maximum number of series LEDs dependent on LED forward voltage). If the primary white LED network should be disconnected, the LM3501 uses internal protection circuitry on the output to prevent a destructive overvoltage event.

A single external resistor is used to set the maximum LED current in LED-drive applications. The LED current can easily be adjusted by varying the analog control voltage on the control pin or by using a pulse width modulated (PWM) signal on the shutdown pin. In shutdown, the LM3501 completely disconnects the input from output, creating total isolation and preventing any leakage currents from trickling into the LEDs.

### Features

- Synchronous rectification, high efficiency and no external schottky diode required
- Uses small surface mount components
- Can drive 2-5 white LEDs in series (may function with more low  $V_F$  LEDs)
- 2.7V to 7V input range
- True shutdown isolation, no LED leakage current
- DC voltage LED current control
- Input undervoltage lockout
- Internal output over-voltage protection (OVP) circuitry, with no external zener diode required LM3501-16: 15.5V OVP; LM3501-21: 20.5V OVP.
- Requires only a small 16V (LM3501-16) or 25V (LM3501-21) ceramic capacitor at the input and output
- Thermal Shutdown
- 0.1 $\mu$ A shutdown current
- Small 8-bump thin micro SMD package

### Applications

- LCD Bias Supplies
- White LED Back-Lighting
- Handheld Devices
- Digital Cameras
- Portable Applications

### Typical Application Circuit

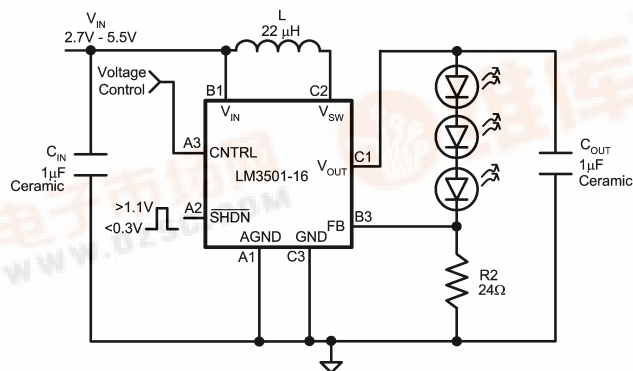

20065301

FIGURE 1. Typical 3 LED Application

Synchronous Step-up DC/DC Converter for White LED Applications



## Connection Diagram

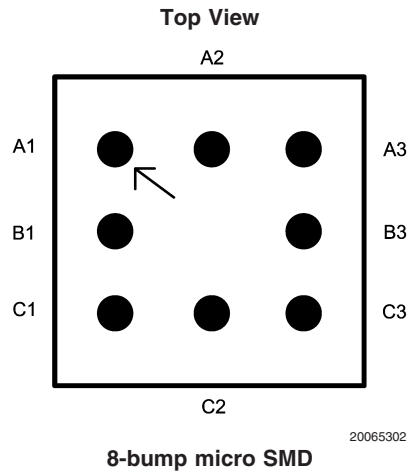

## Ordering Information

Order Number	Package Type	NSC Package Drawing	Top Mark	Supplied As
LM3501TL-16	micro SMD	TL08SSA	19	250 Units, Tape and Reel
LM3501TLX-16	micro SMD	TL08SSA	19	3000 Units, Tape and Reel
LM3501TL-21	micro SMD	TL08SSA	30	250 Units, Tape and Reel
LM3501TLX-21	micro SMD	TL08SSA	30	3000 Units, Tape and Reel

## Pin Description/Functions

Pin	Name	Function
A1	AGND	Analog ground.
B1	$V_{IN}$	Analog and Power supply input.
C1	$V_{OUT}$	PMOS source connection for synchronous rectification.
C2	$V_{SW}$	Switch pin. Drain connections of both NMOS and PMOS power devices.
C3	GND	Power Ground.
B3	FB	Output voltage feedback connection.
A3	CNTRL	Analog LED current control.
A2	$\overline{SHDN}$	Shutdown control pin.

**AGND (pin A1):** Analog ground pin. The analog ground pin should tie directly to the GND pin.

**$V_{IN}$  (pin B1):** Analog and Power supply pin. Bypass this pin with a capacitor, as close to the device as possible, connected between the  $V_{IN}$  and GND pins.

**$V_{OUT}$  (pin C1):** Source connection of internal PMOS power device. Connect the output capacitor between the  $V_{OUT}$  and GND pins as close as possible to the device.

**$V_{SW}$  (pin C2):** Drain connection of internal NMOS and PMOS switch devices. Keep the inductor connection close to this pin to minimize EMI radiation.

**GND (pin C3):** Power ground pin. Tie directly to ground plane.

**FB (pin B3):** Output voltage feedback connection. Set the primary White LED network current with a resistor from the FB pin to GND. Keep the current setting resistor close to the device and connected between the FB and GND pins.

**CNTRL (pin A3):** Analog control of LED current. A voltage above 125 mV will begin to regulate the LED current. Decreasing the voltage below 75 mV will turn off the LEDs.

**$\overline{SHDN}$  (pin A2):** Shutdown control pin. Disable the device with a voltage less than 0.3V and enable the device with a voltage greater than 1.1V. The white LED current can be controlled using a PWM signal at this pin. There is an internal pull down on the  $\overline{SHDN}$  pin, the device is in a normally off state.

**Absolute Maximum Ratings** (Note 1)

If Military/Aerospace specified devices are required, please contact the National Semiconductor Sales Office/Distributors for availability and specifications.

$V_{IN}$	-0.3V to 7.5V
$V_{OUT}$ (LM3501-16)(Note 2)	-0.3V to 16V
$V_{OUT}$ (LM3501-21)(Note 2)	-0.3V to 21V
$V_{SW}$ (Note 2)	-0.3V to $V_{OUT}+0.3V$
FB Voltage	-0.3V to 7.5V
SHDN Voltage	-0.3V to $V_{IN}+0.3V$
CNTRL	-0.3V to 7.5V
Maximum Junction Temperature	150°C
Lead Temperature (Soldering 10 sec.)	300°C
Vapor Phase (60 sec.)	215°C
Infrared (15 sec.)	220°C

## ESD Ratings (Note 3)

Human Body Model	2kV
Machine Model	200V

**Operating Conditions**

Junction Temperature (Note 4)	-40°C to +125°C
Supply Voltage	2.7V to 7V
CNTRL Max.	2.7V

**Thermal Properties**

Junction to Ambient Thermal Resistance ( $\theta_{JA}$ ) (Note 5)	75°C/W
--	--------

**Electrical Characteristics**

Specifications in standard type face are for  $T_A = 25^\circ\text{C}$  and those in **boldface type** apply over the **Operating Temperature Range of  $T_A = -10^\circ\text{C}$  to  $+85^\circ\text{C}$** . Unless otherwise specified  $V_{IN} = 2.7\text{V}$  and specifications apply to both LM3501-16 and LM3501-21.

Symbol	Parameter	Conditions	Min (Note 6)	Typ (Note 7)	Max (Note 6)	Units
$I_Q$	Quiescent Current, Device Not Switching	FB > 0.54V		0.95	<b>1.2</b>	mA
	Quiescent Current, Device Switching	FB = 0V		2	<b>2.5</b>	
	Shutdown	SHDN = 0V		0.1	<b>2</b>	$\mu\text{A}$
$V_{FB}$	Feedback Voltage	CNTRL = 2.7V, $V_{IN} = 2.7\text{V}$ to 7V	<b>0.485</b>	0.515	<b>0.545</b>	V
		CNTRL = 1V, $V_{IN} = 2.7\text{V}$ to 7V	<b>0.14</b>	0.19	<b>0.24</b>	
$\Delta V_{FB}$	Feedback Voltage Line Regulation	$V_{IN} = 2.7\text{V}$ to 7V		0.1	<b>0.5</b>	%/V
$I_{CL}$	Switch Current Limit (LM3501-16)	$V_{IN} = 2.7\text{V}$ , Duty Cycle = 80%	<b>275</b>	400	<b>480</b>	mA
		$V_{IN} = 3.0\text{V}$ , Duty Cycle = 70%	<b>255</b>	400	<b>530</b>	
	Switch Current Limit (LM3501-21)	$V_{IN} = 2.7\text{V}$ , Duty Cycle = 70%	<b>420</b>	640	<b>770</b>	
		$V_{IN} = 3.0\text{V}$ , Duty Cycle = 63%	<b>450</b>	670	<b>800</b>	
$I_B$	FB Pin Bias Current	FB = 0.5V (Note 8)		45	<b>200</b>	nA
$V_{IN}$	Input Voltage Range		<b>2.7</b>		<b>7.0</b>	V
$R_{DS(on)}$	NMOS Switch $R_{DS(on)}$	$V_{IN} = 2.7\text{V}$ , $I_{SW} = 300\text{mA}$			0.43	$\Omega$
	PMOS Switch $R_{DS(on)}$	$V_{OUT} = 6\text{V}$ , $I_{SW} = 300\text{mA}$		1.3	<b>2.3</b>	
$D_{Limit}$	Duty Cycle Limit (LM3501-16)	FB = 0V	<b>80</b>	87		%
	Duty Cycle Limit (LM3501-21)	FB = 0V	<b>85</b>	94		
$F_{SW}$	Switching Frequency		<b>0.85</b>	1.0	<b>1.15</b>	MHz

## Electrical Characteristics (Continued)

Specifications in standard type face are for  $T_A = 25^\circ\text{C}$  and those in **boldface type** apply over the **Operating Temperature Range of  $T_A = -10^\circ\text{C}$  to  $+85^\circ\text{C}$** . Unless otherwise specified  $V_{IN} = 2.7\text{V}$  and specifications apply to both LM3501-16 and LM3501-21.

Symbol	Parameter	Conditions	Min (Note 6)	Typ (Note 7)	Max (Note 6)	Units
$I_{SD}$	SHDN Pin Current (Note 9)	$\overline{\text{SHDN}} = 5.5\text{V}$		1.8	<b>4</b>	$\mu\text{A}$
		$\overline{\text{SHDN}} = 2.7\text{V}$		1	<b>2.5</b>	
		$\overline{\text{SHDN}} = \text{GND}$		0.1		
$I_{CNTRL}$	CNTRL Pin Current (Note 9)	$V_{CNTRL} = 2.7\text{V}$		10	<b>20</b>	$\mu\text{A}$
		$V_{CNTRL} = 1\text{V}$		4	<b>15</b>	
$I_L$	Switch Leakage Current (LM3501-16)	$V_{SW} = 15\text{V}$		0.01	<b>0.5</b>	$\mu\text{A}$
	Switch Leakage Current (LM3501-21)	$V_{SW} = 20\text{V}$		0.01	<b>2.0</b>	
UVP	Input Undervoltage Lockout	ON Threshold	<b>2.4</b>	2.5	<b>2.6</b>	V
		OFF Threshold	<b>2.3</b>	2.4	<b>2.5</b>	
OVP	Output Overvoltage Protection (LM3501-16)	ON Threshold	<b>15</b>	15.5	<b>16</b>	V
		OFF Threshold	<b>14</b>	14.6	<b>15</b>	
	Output Overvoltage Protection (LM3501-21)	ON Threshold	<b>20</b>	20.5	<b>21</b>	V
		OFF Threshold	<b>19</b>	19.5	<b>20</b>	
$I_{Vout}$	$V_{OUT}$ Bias Current (LM3501-16)	$V_{OUT} = 15\text{V}, \overline{\text{SHDN}} = 1.5\text{V}$		260	<b>400</b>	$\mu\text{A}$
	$V_{OUT}$ Bias Current (LM3501-21)	$V_{OUT} = 20\text{V}, \overline{\text{SHDN}} = 1.5\text{V}$		300	<b>460</b>	
$I_{VL}$	PMOS Switch Leakage Current (LM3501-16)	$V_{OUT} = 15\text{V}, V_{SW} = 0\text{V}$		0.01	<b>3</b>	$\mu\text{A}$
	PMOS Switch Leakage Current (LM3501-21)	$V_{OUT} = 20\text{V}, V_{SW} = 0\text{V}$		0.01	<b>3</b>	
CNTRL Threshold		LED power off		75		mV
		LED power on		125		
SHDN Threshold	$\overline{\text{SHDN}}$ low			0.65	<b>0.3</b>	V
	$\overline{\text{SHDN}}$ High		<b>1.1</b>	0.65		

Specifications in standard type face are for  $T_J = 25^\circ\text{C}$  and those in **boldface type** apply over the full **Operating Temperature Range ( $T_J = -40^\circ\text{C}$  to  $+125^\circ\text{C}$ )**. Unless otherwise specified  $V_{IN} = 2.7\text{V}$  and specifications apply to both LM3501-16 and LM3501-21.

Symbol	Parameter	Conditions	Min (Note 6)	Typ (Note 7)	Max (Note 6)	Units
$I_Q$	Quiescent Current, Device Not Switching	$\text{FB} > 0.54\text{V}$		0.95	<b>1.2</b>	mA
	Quiescent Current, Device Switching	$\text{FB} = 0\text{V}$		2	<b>2.5</b>	
	Shutdown	$\overline{\text{SHDN}} = 0\text{V}$		0.1	<b>2</b>	$\mu\text{A}$
$V_{FB}$	Feedback Voltage	$\text{CNTRL} = 2.7\text{V}, V_{IN} = 2.7\text{V}$ to $7\text{V}$	<b>0.485</b>	0.515	<b>0.545</b>	V
		$\text{CNTRL} = 1\text{V}, V_{IN} = 2.7\text{V}$ to $7\text{V}$	<b>0.14</b>	0.19	<b>0.24</b>	
$\Delta V_{FB}$	Feedback Voltage Line Regulation	$V_{IN} = 2.7\text{V}$ to $7\text{V}$		0.1	<b>0.5</b>	%/V
$I_{CL}$	Switch Current Limit (LM3501-16)	$V_{IN} = 3.0\text{V}$ , Duty Cycle = 70%		400		mA
	Switch Current Limit (LM3501-21)	$V_{IN} = 3.0\text{V}$ , Duty Cycle = 63%		670		
$I_B$	FB Pin Bias Current	$\text{FB} = 0.5\text{V}$ (Note 8)		45	<b>200</b>	nA
$V_{IN}$	Input Voltage Range		<b>2.7</b>		<b>7.0</b>	V

## Electrical Characteristics (Continued)

Specifications in standard type face are for  $T_J = 25^\circ\text{C}$  and those in **boldface type** apply over the full **Operating Temperature Range ( $T_J = -40^\circ\text{C}$  to  $+125^\circ\text{C}$ )**. Unless otherwise specified  $V_{IN} = 2.7\text{V}$  and specifications apply to both LM3501-16 and LM3501-21.

Symbol	Parameter	Conditions	Min (Note 6)	Typ (Note 7)	Max (Note 6)	Units
$R_{\text{DSON}}$	NMOS Switch $R_{\text{DSON}}$	$V_{\text{IN}} = 2.7\text{V}$ , $I_{\text{SW}} = 300\text{ mA}$			0.43	$\Omega$
	PMOS Switch $R_{\text{DSON}}$	$V_{\text{OUT}} = 6\text{V}$ , $I_{\text{SW}} = 300\text{ mA}$		1.3	<b>2.3</b>	
$D_{\text{Limit}}$	Duty Cycle Limit (LM3501-16)	$\text{FB} = 0\text{V}$		87		%
	Duty Cycle Limit (LM3501-21)	$\text{FB} = 0\text{V}$		94		
$F_{\text{SW}}$	Switching Frequency		<b>0.8</b>	1.0	<b>1.2</b>	MHz
$I_{\text{SD}}$	SHDN Pin Current (Note 9)	$\overline{\text{SHDN}} = 5.5\text{V}$		1.8	<b>4</b>	$\mu\text{A}$
		$\overline{\text{SHDN}} = 2.7\text{V}$		1	<b>2.5</b>	
		$\overline{\text{SHDN}} = \text{GND}$		0.1		
$I_{\text{CNTRL}}$	CNTRL Pin Current (Note 9)	$V_{\text{CNTRL}} = 2.7\text{V}$		10	<b>20</b>	$\mu\text{A}$
		$V_{\text{CNTRL}} = 1\text{V}$		4	<b>15</b>	
$I_{\text{L}}$	Switch Leakage Current (LM3501-16)	$V_{\text{SW}} = 15\text{V}$		0.01	<b>0.5</b>	$\mu\text{A}$
	Switch Leakage Current (LM3501-21)	$V_{\text{SW}} = 20\text{V}$		0.01	<b>2.0</b>	
UVP	Input Undervoltage Lockout	ON Threshold	<b>2.4</b>	2.5	<b>2.6</b>	V
		OFF Threshold	<b>2.3</b>	2.4	<b>2.5</b>	
OVP	Output Overvoltage Protection (LM3501-16)	ON Threshold	<b>15</b>	15.5	<b>16</b>	V
		OFF Threshold	<b>14</b>	14.6	<b>15</b>	
	Output Overvoltage Protection (LM3501-21)	ON Threshold	<b>20</b>	20.5	<b>21</b>	
		OFF Threshold	<b>19</b>	19.5	<b>20</b>	
$I_{\text{Vout}}$	$V_{\text{OUT}}$ Leakage Current (LM3501-16)	$V_{\text{OUT}} = 15\text{V}$ , $\overline{\text{SHDN}} = 1.5\text{V}$		260	<b>400</b>	$\mu\text{A}$
	$V_{\text{OUT}}$ Leakage Current (LM3501-21)	$V_{\text{OUT}} = 20\text{V}$ , $\overline{\text{SHDN}} = 1.5\text{V}$		300	<b>460</b>	
$I_{\text{VL}}$	PMOS Switch Leakage Current (LM3501-16)	$V_{\text{OUT}} = 15\text{V}$ , $V_{\text{SW}} = 0\text{V}$		0.01	<b>3</b>	$\mu\text{A}$
	PMOS Switch Leakage Current (LM3501-21)	$V_{\text{OUT}} = 20\text{V}$ , $V_{\text{SW}} = 0\text{V}$		0.01	<b>3</b>	
CNTRL Threshold		LED power off		75		mV
		LED power on		125		
SHDN Threshold	$\overline{\text{SHDN}}$ low			0.65	<b>0.3</b>	V
	$\overline{\text{SHDN}}$ High		<b>1.1</b>	0.65		

**Note 1:** Absolute maximum ratings are limits beyond which damage to the device may occur. Operating Ratings are conditions for which the device is intended to be functional, but device parameter specifications may not be guaranteed. For guaranteed specifications and test conditions, see the Electrical Characteristics.

**Note 2:** This condition applies if  $V_{\text{IN}} < V_{\text{OUT}}$ . If  $V_{\text{IN}} > V_{\text{OUT}}$ , a voltage greater than  $V_{\text{IN}} + 0.3\text{V}$  should not be applied to the  $V_{\text{OUT}}$  or  $V_{\text{SW}}$  pins.

**Note 3:** The human body model is a 100 pF capacitor discharged through a 1.5 k $\Omega$  resistor into each pin. The machine model is a 200 pF capacitor discharged directly into each pin.

**Note 4:** The maximum allowable power dissipation is a function of the maximum operating junction temperature,  $T_{\text{J(MAX)}}$ , the junction-to-ambient thermal resistance,  $\theta_{\text{JA}}$ , and the ambient temperature,  $T_{\text{A}}$ . See the *Thermal Properties* section for the thermal resistance. The maximum allowable power dissipation at any ambient temperature is calculated using:  $P_{\text{D (MAX)}} = (T_{\text{J(MAX)}} - T_{\text{A}})/\theta_{\text{JA}}$ . Exceeding the maximum allowable power dissipation will cause excessive die temperature.

**Note 5:** Junction-to-ambient thermal resistance ( $\theta_{\text{JA}}$ ) is highly application and board-layout dependent. The 75°C/W figure provided was measured on a 4-layer test board conforming to JEDEC standards. In applications where high maximum power dissipation exists, special care must be paid to thermal dissipation issues when designing the board layout.

**Note 6:** All limits guaranteed at room temperature (standard typeface) and at temperature extremes (bold typeface). All room temperature limits are production tested, guaranteed through statistical analysis or guaranteed by design. All limits at temperature extremes are guaranteed via correlation using standard Statistical Quality Control (SQC) methods. All limits are used to calculate Average Outgoing Quality Level (AOQL).

**Note 7:** Typical numbers are at 25°C and represent the most likely norm.

**Note 8:** Feedback current flows out of the pin.

**Note 9:** Current flows into the pin.

## Typical Performance Characteristics

Switching Quiescent Current vs.  $V_{IN}$

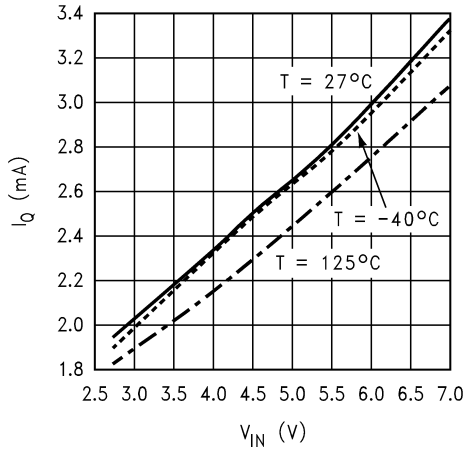

20065355

Non-Switching Quiescent Current vs.  $V_{IN}$

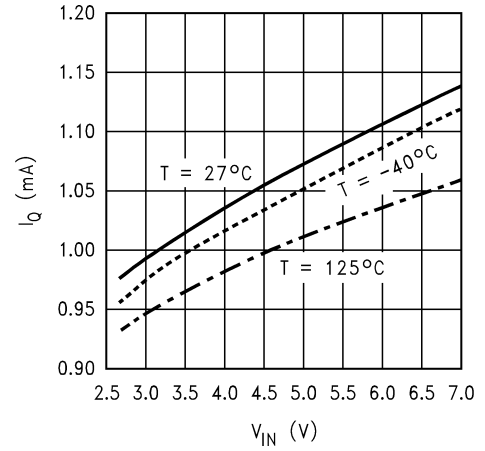

20065356

2 LED Efficiency vs. Load Current  
L = Coilcraft DT1608C-223,  
Efficiency =  $100 \cdot (P_{IN} / (2V_{LED} \cdot I_{LED}))$

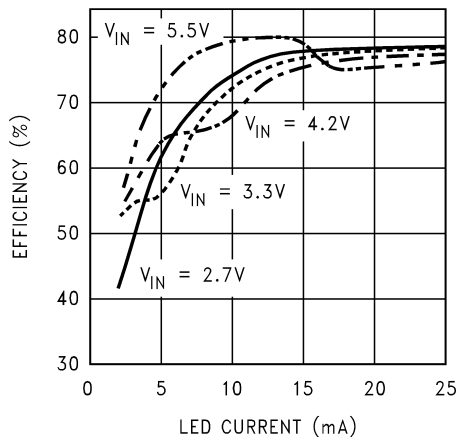

20065357

3 LED Efficiency vs. Load Current  
L = Coilcraft DT1608C-223,  
Efficiency =  $100 \cdot (P_{IN} / (3V_{LED} \cdot I_{LED}))$

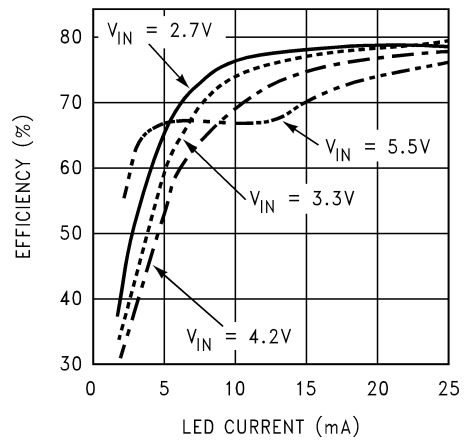

20065358

4 LED Efficiency vs. Load Current  
L = Coilcraft DT1608C-223,  
Efficiency =  $100 \cdot (P_{IN} / (4V_{LED} \cdot I_{LED}))$

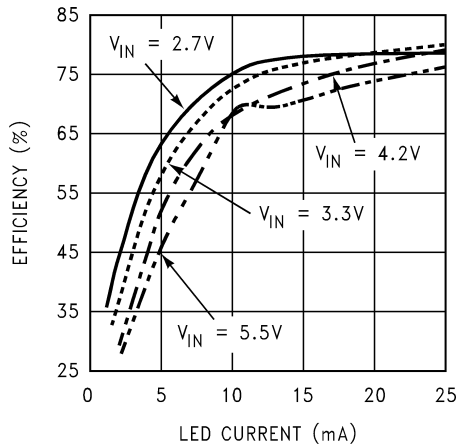

20065359

Output Power vs.  $V_{IN}$   
(LM3501-16, L = Coilcraft DT1608C-223)

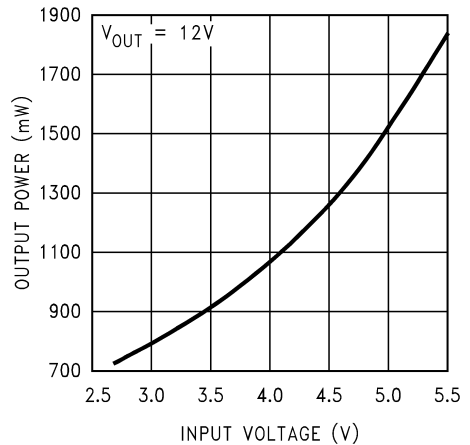

20065386

Typical Performance Characteristics (Continued)

Output Power vs. Temperature  
(LM3501-16, L = Coilcraft DT1608C-223)

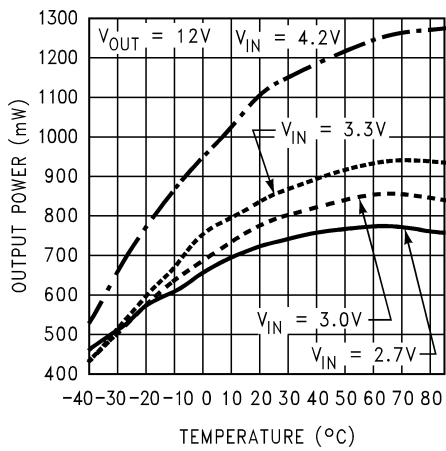

FB Pin Current vs. Temperature

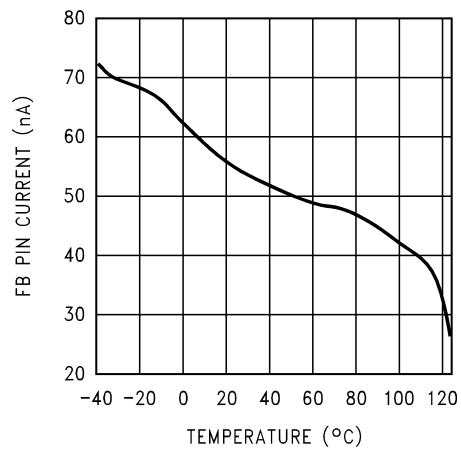

SHDN Pin Current vs. SHDN Pin Voltage

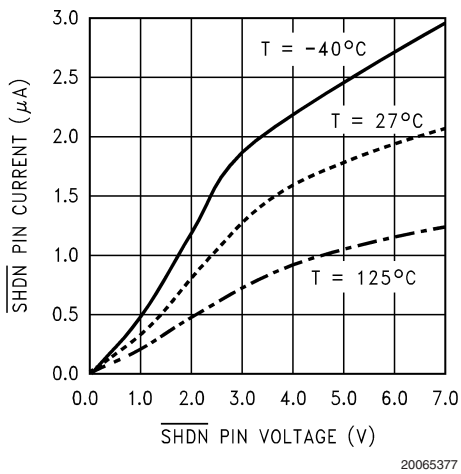

CNTRL Pin Current vs. CNTRL Pin Voltage

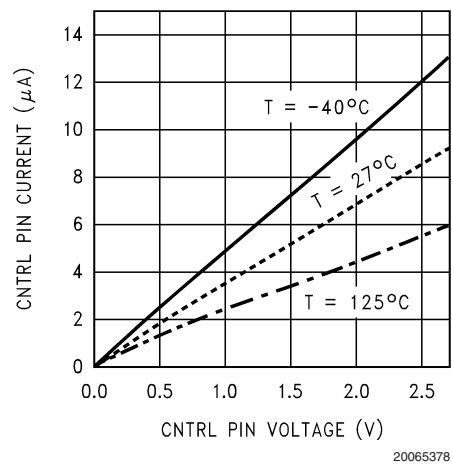

FB Voltage vs. CNTRL Voltage

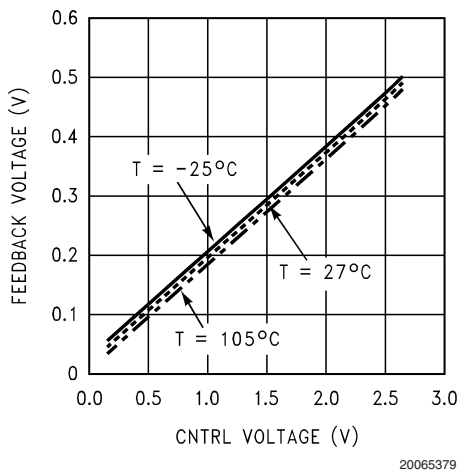

Switch Current Limit vs. VIN  
(LM3501-16)

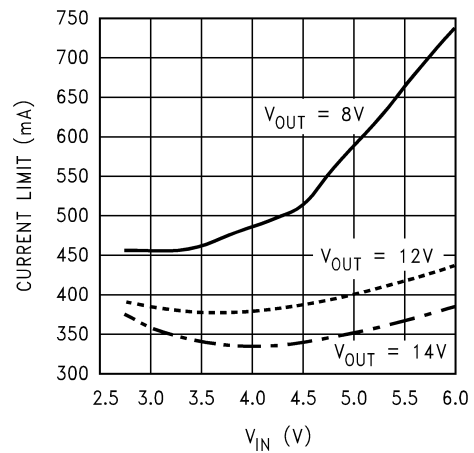

## Typical Performance Characteristics (Continued)

Switch Current Limit vs. Temperature  
(LM3501-16,  $V_{OUT} = 8V$ )

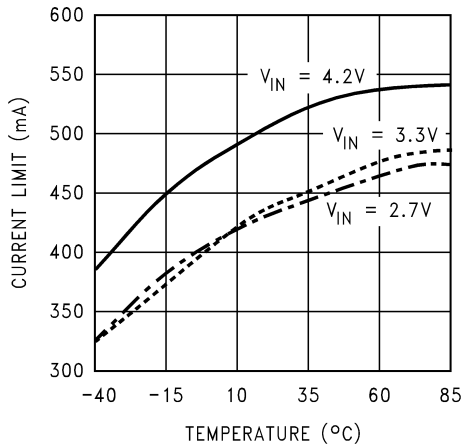

Switch Current Limit vs. Temperature  
(LM3501-16,  $V_{OUT} = 12V$ )

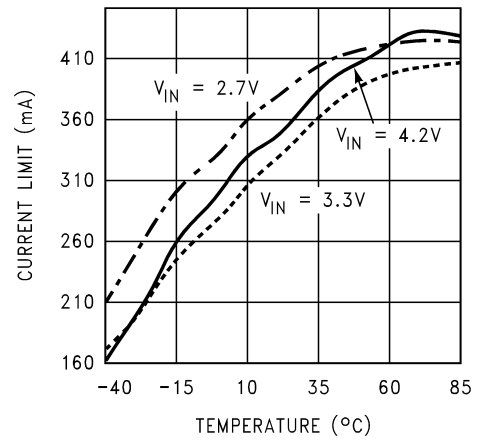

Switch Current Limit vs.  $V_{IN}$   
(LM3501-21)

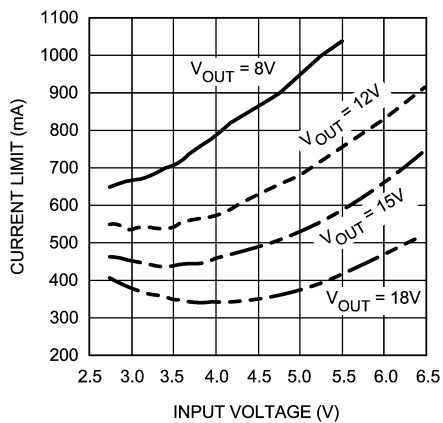

Switch Current Limit vs. Temperature  
(LM3501-21,  $V_{OUT} = 8V$ )

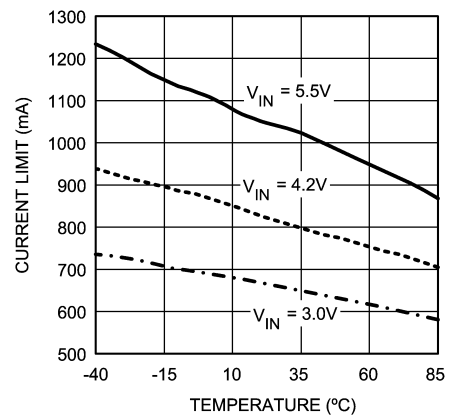

Switch Current Limit vs. Temperature  
(LM3501-21,  $V_{OUT} = 12V$ )

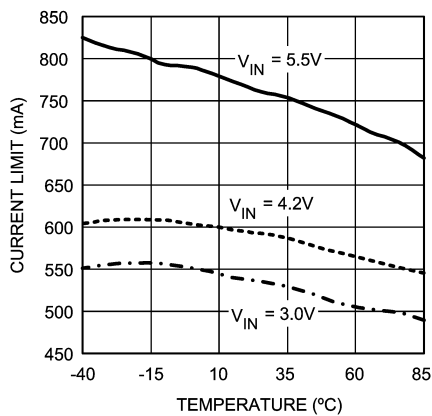

Switch Current Limit vs. Temperature  
(LM3501-21,  $V_{OUT} = 18V$ )

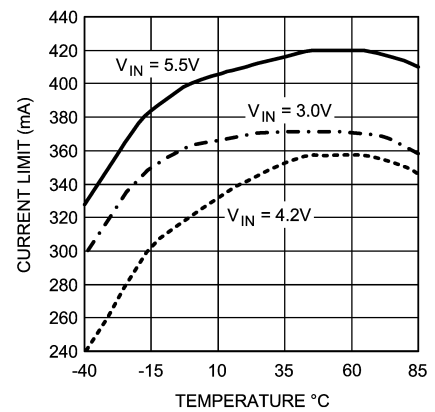



Typical Performance Characteristics (Continued)

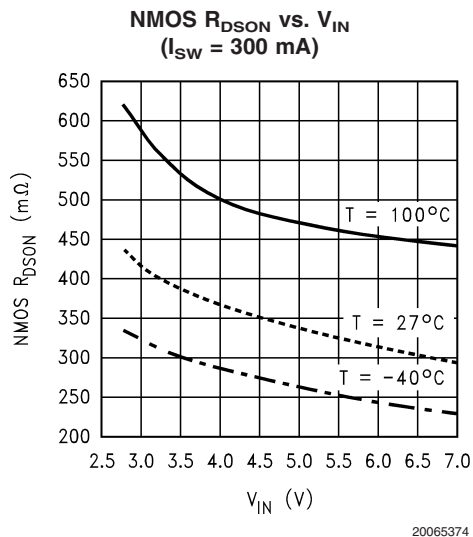
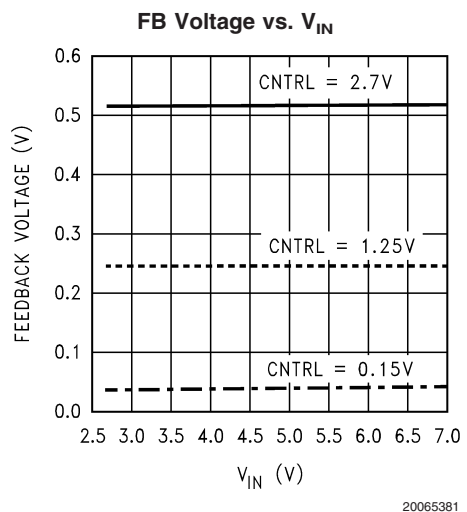
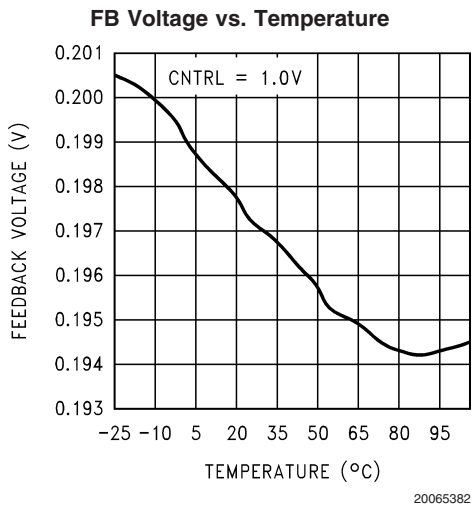
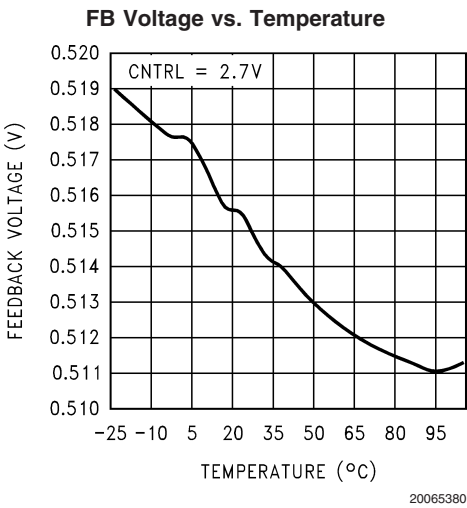
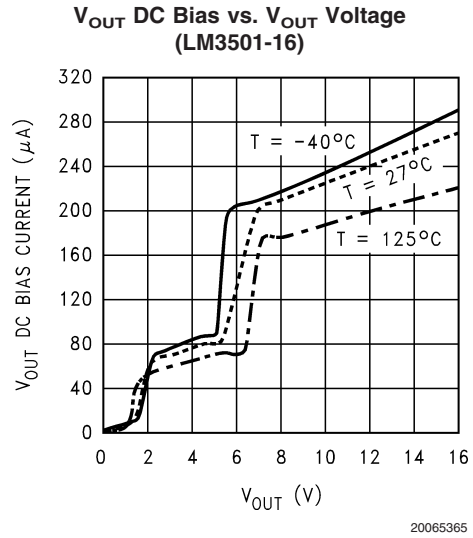
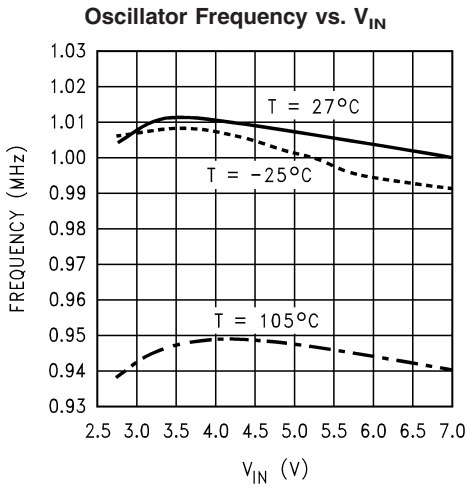

## Typical Performance Characteristics (Continued)

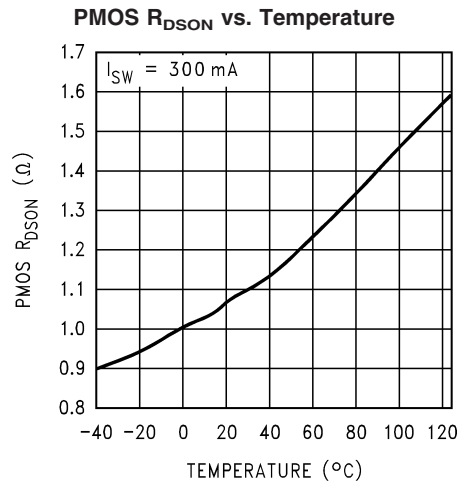

20065375

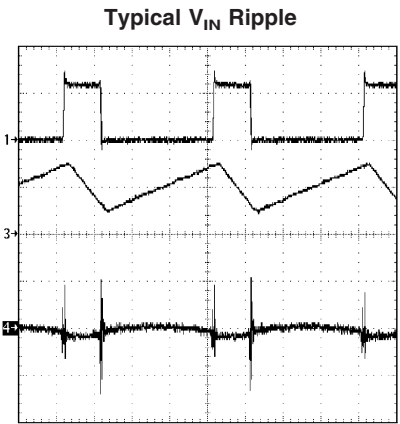

20065368

3 LEDs,  $R_{LED} = 22\Omega$ ,  $V_{IN} = 3.0\text{V}$ ,  $CNTRL = 2.7\text{V}$

1) SW, 10 V/div, DC

3)  $I_L$ , 100 mA/div, DC

4)  $V_{IN}$ , 100 mV/div, AC

T = 250 ns/div

### Start-Up (LM3501-16)

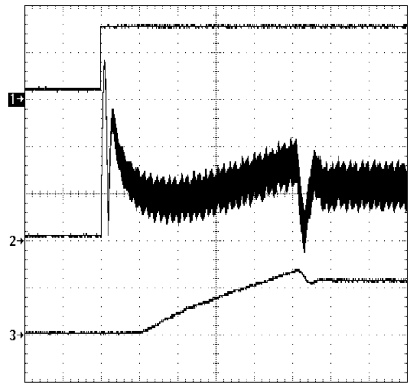

20065371

3 LEDs,  $R_{LED} = 22\Omega$ ,  $V_{IN} = 3.0\text{V}$ ,  $CNTRL = 2.7\text{V}$

1)  $\overline{\text{SHDN}}$ , 1 V/div, DC

2)  $I_L$ , 100 mA/div, DC

3)  $I_{LED}$ , 20 mA/div, DC

T = 100  $\mu\text{s}$ /div

### $\overline{\text{SHDN}}$ Pin Duty Cycle Control Waveforms

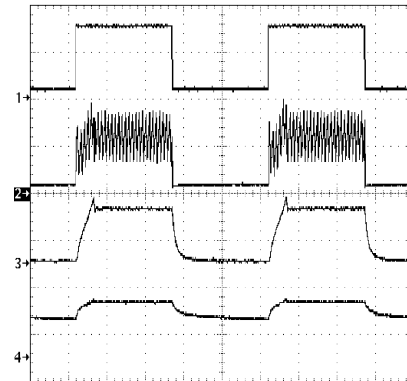

20065346

LM3501-16, 3 LEDs,  $R_{LED} = 22\Omega$ ,  $V_{IN} = 3.0\text{V}$ ,  $\overline{\text{SHDN}}$  frequency = 200 Hz

1)  $\overline{\text{SHDN}}$ , 1 V/div, DC

2)  $I_L$ , 100 mA/div, DC

3)  $I_{LED}$ , 20 mA/div, DC

4)  $V_{OUT}$ , 10 V/div, DC

T = 1 ms/div

## Typical Performance Characteristics (Continued)

### Typical $V_{OUT}$ Ripple, OVP Functioning (LM3501-16)

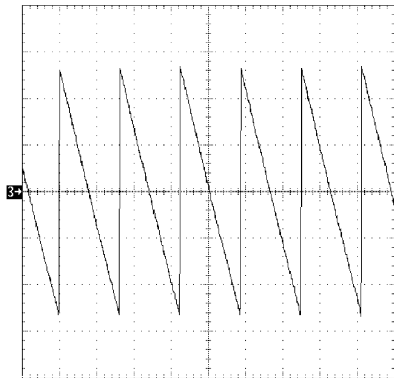

20065383

$V_{OUT}$  open circuit and equals approximately 15V DC,  $V_{IN} = 3.0V$

3)  $V_{OUT}$ , 200 mV/div, AC

T = 1 ms/div

### Typical $V_{OUT}$ Ripple, OVP Functioning (LM3501-21)

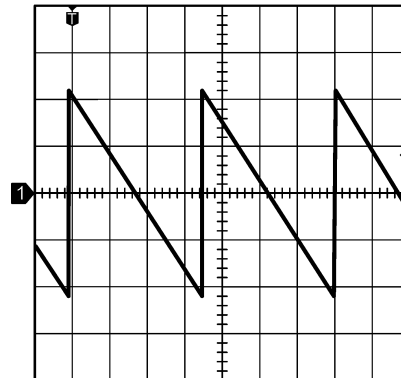

20065347

$V_{OUT}$  open circuit and equals approximately 20V DC,  $V_{IN} = 3.0V$

1)  $V_{OUT}$ , 200 mV/div, AC

T = 400  $\mu$ s/div

## Operation

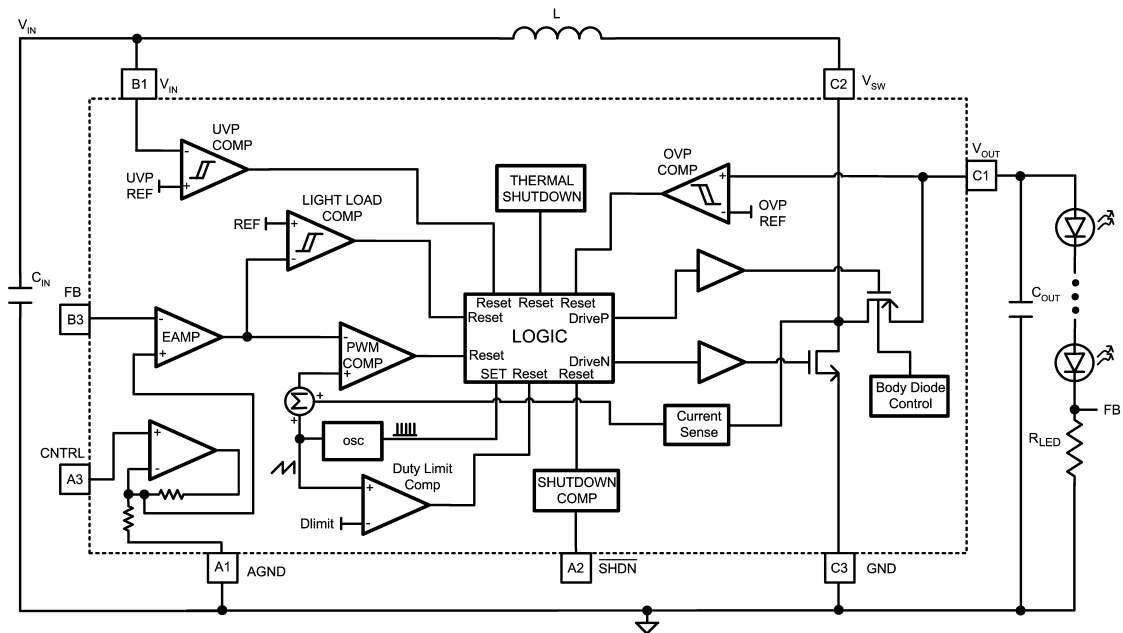

20065304

FIGURE 2. LM3501 Block Diagram

The LM3501 utilizes a synchronous Current Mode PWM control scheme to regulate the feedback voltage over almost all load conditions. The DC/DC controller acts as a controlled current source ideal for white LED applications. The LM3501 is internally compensated preventing the use of any external compensation components providing a compact overall solution. The operation can best be understood referring to the block diagram in *Figure 2*. At the start of each cycle, the oscillator sets the driver logic and turns on the NMOS power device conducting current through the inductor and turns off the PMOS power device isolating the output from the  $V_{SW}$  pin. The LED current is supplied by the output capacitor when the NMOS power device is active. During this cycle, the output voltage of the EAMP controls the current through the inductor. This voltage will increase for larger loads and decrease for smaller loads limiting the peak current in the inductor minimizing EMI radiation. The EAMP voltage is compared with a voltage ramp and the sensed switch voltage. Once this voltage reaches the EAMP output voltage, the PWM COMP will then reset the logic turning off the NMOS power device and turning on the PMOS power device. The inductor current then flows through the PMOS power device to the white LED load and output capacitor. The inductor current recharges the output capacitor and supplies the current for the white LED branches. The oscillator then sets the driver logic again repeating the process.

The Duty Limit Comp is always operational preventing the NMOS power switch from being on more than one cycle and conducting large amounts of current.

The LM3501 has dedicated protection circuitry active during normal operation to protect the IC and the external components. The Thermal Shutdown circuitry turns off both the NMOS and PMOS power devices when the die temperature reaches excessive levels. The LM3501 has a UVP Comp that disables both the NMOS and PMOS power devices when battery voltages are too low preventing an on state of the power devices which could conduct large amounts of current. The OVP Comp prevents the output voltage from increasing beyond 15.5V (LM3501-16) and 20.5V (LM3501-21) when the primary white LED network is removed or if there is an LED failure, allowing the use of small (16V for LM3501-16 and 25V for LM3501-21) ceramic capacitors at the output. This comparator has hysteresis that will regulate the output voltage between 15.5V and 14.6V typically for the LM3501-16, and between 20.5V and 19.5V for the LM3501-21. The LM3501 features a shutdown mode that reduces the supply current to 0.1  $\mu$ A and isolates the input and output of the converter. The CNTRL pin can be used to change the white LED current. A CNTRL voltage above 125 mV will enable power to the LEDs and a voltage lower than 75 mV will turn off the power to the LEDs.

## Application Information

### ADJUSTING LED CURRENT

The maximum White LED current is set using the following equation:

$$I_{LED} = V_{FB(MAX)} / R_{LED}$$

The LED current can be controlled using an external DC voltage. The recommended operating range for the voltage on the CNTRL pin is 0V to 2.7V. When CNTRL is 2.7V, FB = 0.515V (typ.) The FB voltage will continue to increase if CNTRL is brought above 2.7V (not recommended). The CNTRL to FB voltage relationship is:

$$FB = 0.191 * CNTRL$$

The LED current can be controlled using a PWM signal on the SHDN pin with frequencies in the range of 100 Hz (greater than visible frequency spectrum) to 1 kHz. For controlling LED currents down to the  $\mu$ A levels, it is best to use a PWM signal frequency between 200-500 Hz. The LM3501 LED current can be controlled with PWM signal frequencies above 1 kHz but the controllable current decreases with higher frequency. The maximum LED current would be achieved using the equation above with 100% duty cycle, ie. the SHDN pin always high.

Applying a voltage greater than 125 mV to the CNTRL pin will begin regulating current to the LEDs. A voltage below 75 mV will prevent application or regulation of the LED current.

### LED-DRIVE CAPABILITY

The maximum number of LEDs that can be driven by the LM3501 is limited by the output voltage capability of the LM3501. When using the LM3501 in the typical application configuration, with LEDs stacked in series between the  $V_{OUT}$  and FB pins, the maximum number of LEDs that can be placed in series ( $N_{MAX}$ ) is dependent on the maximum LED forward voltage ( $V_{F-MAX}$ ), the voltage of the LM3501 feedback pin ( $V_{FB-MAX} = 0.545V$ ), and the minimum output over-voltage protection level of the chosen LM3501 option (LM3501-16:  $OVP_{MIN} = 15V$ ; LM3501-21:  $OVP_{MIN} = 20V$ ). For the circuit to function properly, the following inequality must be met:

$$(N_{MAX} \times V_{F-MAX}) + 0.545V \leq OVP_{MIN}$$

When inserting a value for maximum LED VF, LED forward voltage variation over the operating temperature range should be considered. The table below provides maximum LED voltage numbers for the LM3501-16 and LM3501-21 in the typical application circuit configuration (with 3, 4, 5, 6, or 7 LEDs placed in series between the  $V_{OUT}$  and FB pins).

# of LEDs (in series)	Maximum LED $V_F$	
	LM3501-16	LM3501-21
3	4.82V	6.49V
4	3.61V	4.86V
5	2.89V	3.89V
6	X	3.24V
7	X	2.78V

For the LM3501 to operate properly, the output voltage must be kept above the input voltage during operation. For most applications, this requires a minimum of 2 LEDs (total of 6V or more) between the FB and  $V_{OUT}$  pins.

### OUTPUT OVERVOLTAGE PROTECTION

The LM3501 contains dedicated circuitry for monitoring the output voltage. In the event that the primary LED network is disconnected from the LM3501-16, the output voltage will increase and be limited to 15.5V (typ.). There is a 900 mV hysteresis associated with this circuitry which will cause the output to fluctuate between 15.5V and 14.6V (typ.) if the primary network is disconnected. In the event that the network is reconnected regulation will begin at the appropriate output voltage. The 15.5V limit allows the use of 16V 1  $\mu$ F ceramic output capacitors creating an overall small solution for white LED applications.

In the event that the primary LED network is disconnected from the LM3501-21, the output voltage will increase and be limited to 20.5V (typ.). There is a 1V hysteresis associated with this circuitry which will cause the output to fluctuate between 20.5V and 19.5V (typ.) if the primary network is disconnected. In the event that the network is reconnected regulation will begin at the appropriate output voltage. The 20.5V limit allows the use of 25V 1  $\mu$ F ceramic output capacitors.

### RELIABILITY AND THERMAL SHUTDOWN

The maximum continuous pin current for the 8 pin thin micro SMD package is 535 mA. When driving the device near its power output limits the  $V_{SW}$  pin can see a higher DC current than 535 mA (see *INDUCTOR SELECTION* section for average switch current). To preserve the long term reliability of the device the average switch current should not exceed 535 mA.

The LM3501 has an internal thermal shutdown function to protect the die from excessive temperatures. The thermal shutdown trip point is typically 150°C. There is a hysteresis of typically 35°C so the die temperature must decrease to approximately 115°C before the LM3501 will return to normal operation.

### INDUCTOR SELECTION

The inductor used with the LM3501 must have a saturation current greater than the cycle by cycle peak inductor current (see *Typical Peak Inductor Currents* table below). Choosing inductors with low DCR decreases power losses and increases efficiency.

## Application Information (Continued)

The minimum inductor value required for the LM3501-16 can be calculated using the following equation:

$$L > \frac{V_{IN} R_{DSON}}{0.29} \left( \frac{D}{D'} - 1 \right)$$

The minimum inductor value required for the LM3501-21 can be calculated using the following equation:

$$L > \frac{V_{IN} R_{DSON}}{0.58} \left( \frac{D}{D'} - 1 \right)$$

For both equations above, L is in  $\mu\text{H}$ ,  $V_{IN}$  is the input supply of the chip in Volts,  $R_{DSON}$  is the ON resistance of the NMOS power switch found in the Typical Performance Characteristics section in ohms and D is the duty cycle of the switching regulator. The above equation is only valid for D greater than or equal to 0.5. For applications where the minimum duty cycle is less than 0.5, a 22  $\mu\text{H}$  inductor is the typical recommendation for use with most applications. Bench-level verification of circuit performance is required in these special cases, however. The duty cycle, D, is given by the following equation:

$$D' = \frac{V_{IN}}{V_{OUT}} = 1 - D$$

where  $V_{OUT}$  is the voltage at pin C1.

Typical Peak Inductor Current (mA)(Note 10)

VIN (V)	# LEDs (in series)	LED Current					
		15 mA	20 mA	30 mA	40 mA	50 mA	60 mA
2.7	2	82	100	134	160	204	234
	3	118	138	190	244	294	352
	4	142	174	244	322	X	X
	5	191	232	319	413	X	X
3.3	2	76	90	116	136	172	198
	3	110	126	168	210	250	290
	4	132	158	212	270	320	X
	5	183	216	288	365	446	X
4.2	2	64	76	96	116	142	162
	3	102	116	148	180	210	246
	4	122	146	186	232	272	318
	5	179	206	263	324	388	456

**Note 10:**  $C_{IN} = C_{OUT} = 1 \mu\text{F}$

L = 22  $\mu\text{H}$ , 160 m $\Omega$  DCR max. Coilcraft DT1608C-223

2 and 3 LED applications: LM3501-16 or LM3501-21; LED  $V_F = 3.77\text{V}$  at 20mA;  $T_A = 25^\circ\text{C}$

4 LED applications: LM3501-16 or LM3501-21; LED  $V_F = 3.41\text{V}$  at 20mA;  $T_A = 25^\circ\text{C}$

5 LED applications: LM3501-21 only; LED  $V_F = 3.28\text{V}$  at 20mA;  $T_A = 25^\circ\text{C}$

The typical cycle-by-cycle peak inductor current can be calculated from the following equation:

$$I_{PK} \approx \frac{I_{OUT}}{\eta D'} + \frac{V_{IN} D}{2LF_{SW}}$$

where  $I_{OUT}$  is the total load current,  $F_{SW}$  is the switching frequency, L is the inductance and  $\eta$  is the converter efficiency of the total driven load. A good typical number to use for  $\eta$  is 0.8. The value of  $\eta$  can vary with load and duty cycle. The average inductor current, which is also the average  $V_{SW}$  pin current, is given by the following equation:

$$I_{L(AVE)} \approx \frac{I_{OUT}}{\eta D'}$$

The maximum output current capability of the LM3501 can be estimated with the following equation:

$$I_{OUT} \approx \eta D' \left( I_{CL} - \frac{V_{IN} D}{2LF_{SW}} \right)$$

where  $I_{CL}$  is the current limit. Some recommended inductors include but are not limited to:

Coilcraft DT1608C series

Coilcraft DO1608C series

TDK VLP4612 series

TDK VLP5610 series

TDK VLF4012A series

### CAPACITOR SELECTION

Choose low ESR ceramic capacitors for the output to minimize output voltage ripple. Multilayer X7R or X5R type ceramic capacitors are the best choice. For most applications, a 1  $\mu\text{F}$  ceramic output capacitor is sufficient.

Local bypassing for the input is needed on the LM3501. Multilayer X7R or X5R ceramic capacitors with low ESR are a good choice for this as well. A 1  $\mu\text{F}$  ceramic capacitor is sufficient for most applications. However, for some applications at least a 4.7  $\mu\text{F}$  ceramic capacitor may be required for proper startup of the LM3501. Using capacitors with low ESR decreases input voltage ripple. For additional bypassing, a 100 nF ceramic capacitor can be used to shunt high frequency ripple on the input. Some recommended capacitors include but are not limited to:

TDK C2012X7R1C105K

Taiyo-Yuden EMK212BJ105 G

### LAYOUT CONSIDERATIONS

The input bypass capacitor  $C_{IN}$ , as shown in *Figure 2*, must be placed close to the device and connect between the  $V_{IN}$  and GND pins. This will reduce copper trace resistance which effects the input voltage ripple of the IC. For additional input voltage filtering, a 100 nF bypass capacitor can be placed in parallel with  $C_{IN}$  to shunt any high frequency noise to ground. The output capacitor,  $C_{OUT}$ , should also be placed close to the LM3501 and connected directly between the  $V_{OUT}$  and GND pins. Any copper trace connections for the  $C_{OUT}$  capacitor can increase the series resistance, which directly effects output voltage ripple and efficiency. The current setting resistor,  $R_{LED}$ , should be kept close to the FB pin

## Application Information (Continued)

to minimize copper trace connections that can inject noise into the system. The ground connection for the current setting resistor should connect directly to the GND pin. The AGND pin should connect directly to the GND pin. Not connecting the AGND pin directly, as close to the chip as possible, may affect the performance of the LM3501 and

limit its current driving capability. Trace connections made to the inductor should be minimized to reduce power dissipation, EMI radiation and increase overall efficiency. It is good practice to keep the  $V_{SW}$  routing away from sensitive pins such as the FB pin. Failure to do so may inject noise into the FB pin and affect the regulation of the device. See *Figure 3* and *Figure 4* for an example of a good layout as used for the LM3501 evaluation board.

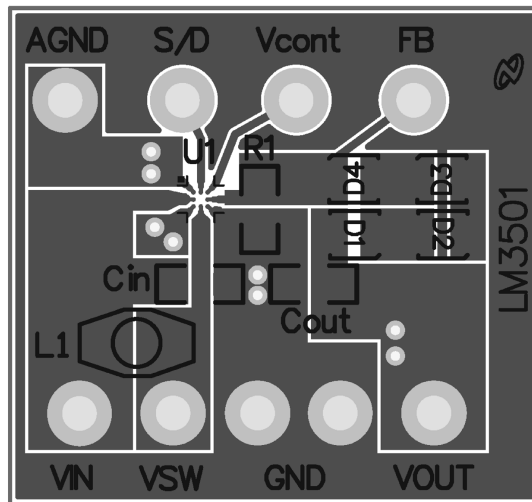

20065384

FIGURE 3. Evaluation Board Layout (2X Magnification)  
Top Layer

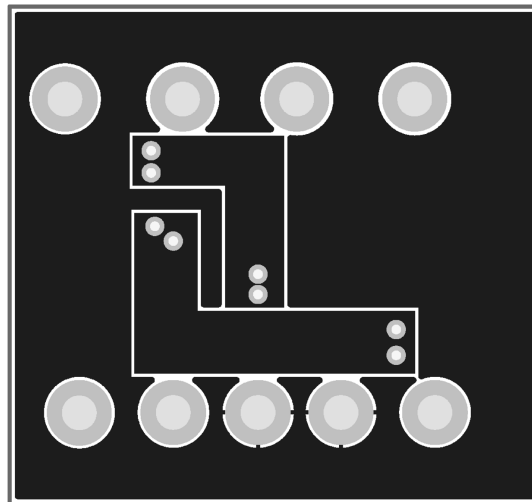

20065385

FIGURE 4. Evaluation Board Layout (2X Magnification)  
Bottom Layer (as viewed from the top)

# Application Information (Continued)

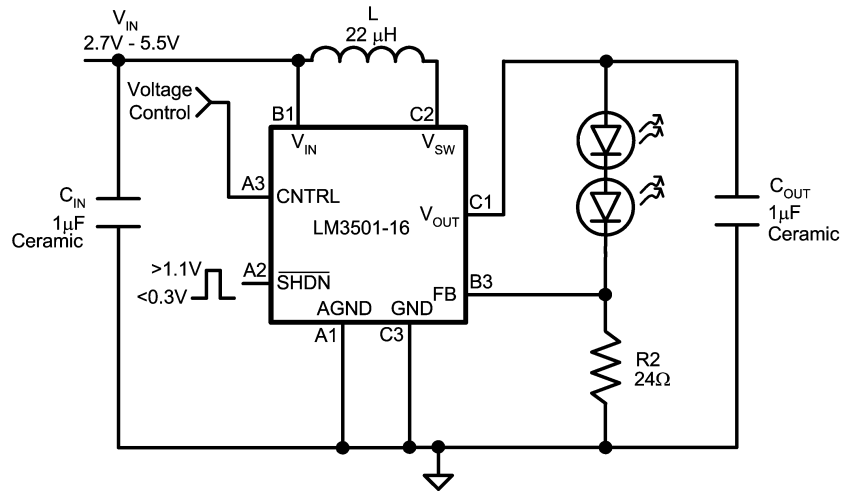

20065309

FIGURE 5. 2 White LED Application

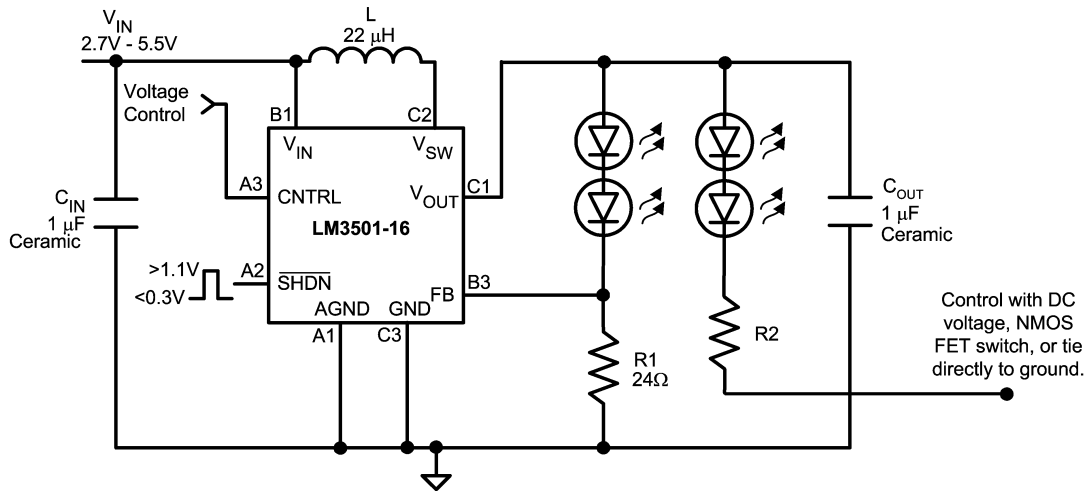

20065366

FIGURE 6. Multiple 2 LED String Application



**Application Information** (Continued)

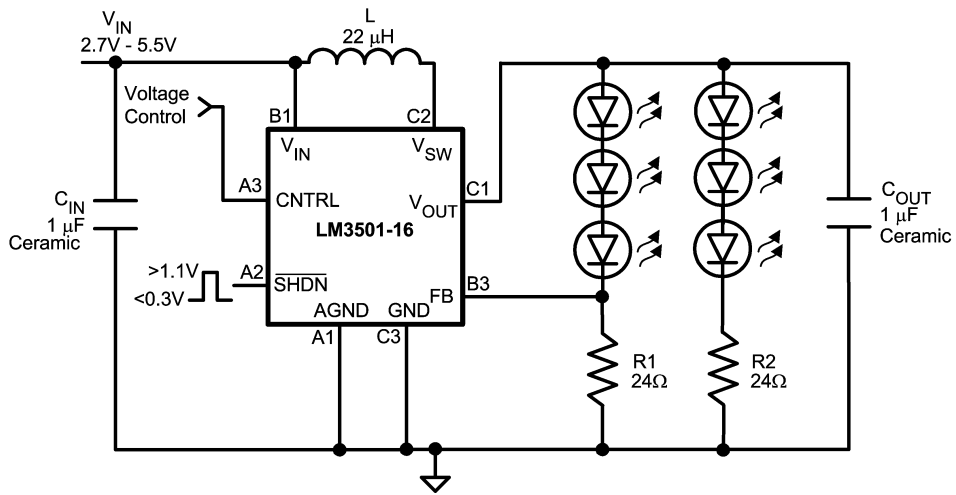

20065367

**FIGURE 7. Multiple 3 LED String Application**

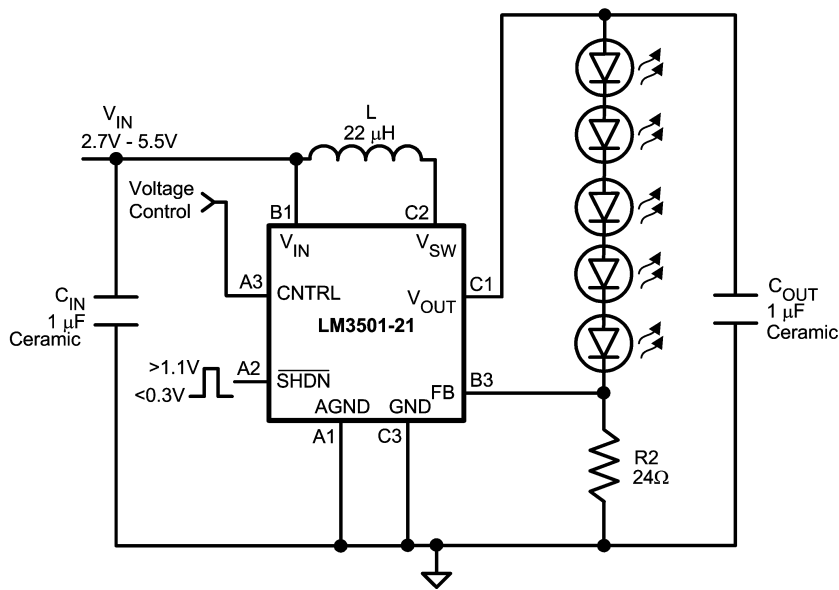

20065369

**FIGURE 8. LM3501-21 5 LED Application**

**Physical Dimensions** inches (millimeters) unless otherwise noted

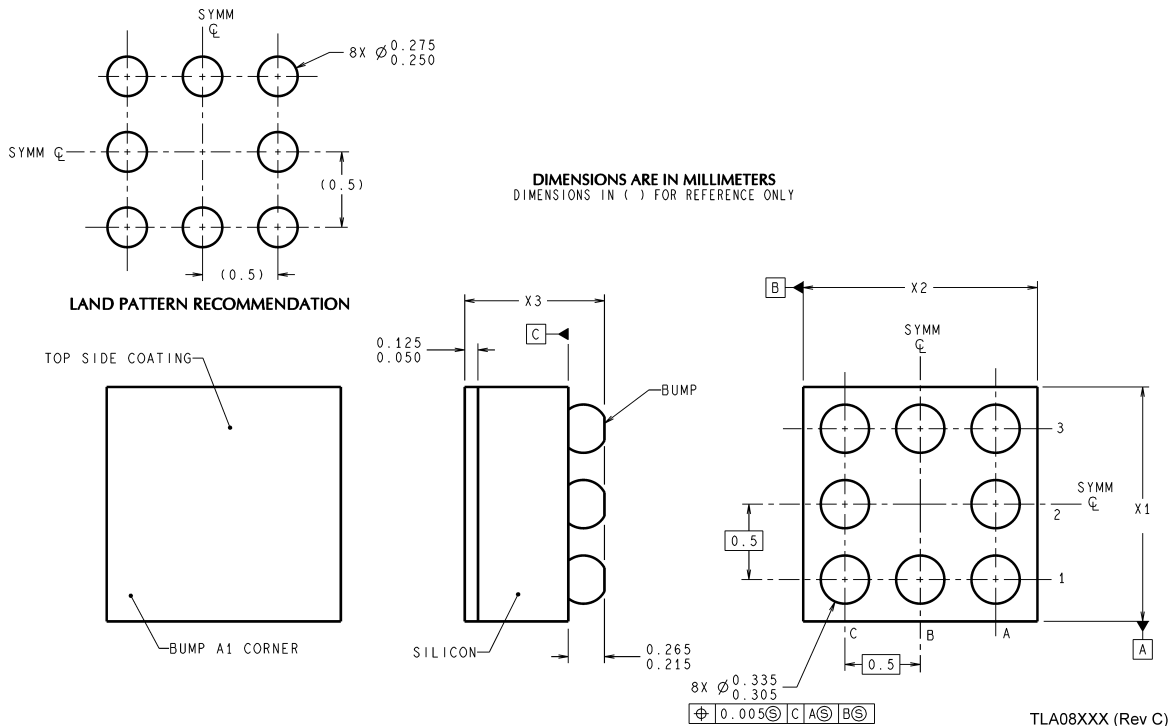

**8-Bump micro SMD Package (TL)**

For Ordering, Refer to Ordering Information Table  
NS Package Number TLA08A

X1 = 1.92 mm (±0.03 mm), X2 = 1.92 mm (±0.03 mm), X3 = 0.6 mm (±0.075 mm)

National does not assume any responsibility for use of any circuitry described, no circuit patent licenses are implied and National reserves the right at any time without notice to change said circuitry and specifications.

For the most current product information visit us at [www.national.com](http://www.national.com).

**LIFE SUPPORT POLICY**

NATIONAL'S PRODUCTS ARE NOT AUTHORIZED FOR USE AS CRITICAL COMPONENTS IN LIFE SUPPORT DEVICES OR SYSTEMS WITHOUT THE EXPRESS WRITTEN APPROVAL OF THE PRESIDENT AND GENERAL COUNSEL OF NATIONAL SEMICONDUCTOR CORPORATION. As used herein:

1. Life support devices or systems are devices or systems which, (a) are intended for surgical implant into the body, or (b) support or sustain life, and whose failure to perform when properly used in accordance with instructions for use provided in the labeling, can be reasonably expected to result in a significant injury to the user.
2. A critical component is any component of a life support device or system whose failure to perform can be reasonably expected to cause the failure of the life support device or system, or to affect its safety or effectiveness.

**BANNED SUBSTANCE COMPLIANCE**

National Semiconductor manufactures products and uses packing materials that meet the provisions of the Customer Products Stewardship Specification (CSP-9-111C2) and the Banned Substances and Materials of Interest Specification (CSP-9-111S2) and contain no "Banned Substances" as defined in CSP-9-111S2.

Leadfree products are RoHS compliant.



**National Semiconductor**  
Americas Customer Support Center  
Email: [new.feedback@nsc.com](mailto:new.feedback@nsc.com)  
Tel: 1-800-272-9959

**National Semiconductor**  
Europe Customer Support Center  
Fax: +49 (0) 180-530 85 86  
Email: [europe.support@nsc.com](mailto:europe.support@nsc.com)  
Deutsch Tel: +49 (0) 69 9508 6208  
English Tel: +44 (0) 870 24 0 2171  
Français Tel: +33 (0) 1 41 91 8790

**National Semiconductor**  
Asia Pacific Customer Support Center  
Email: [ap.support@nsc.com](mailto:ap.support@nsc.com)

**National Semiconductor**  
Japan Customer Support Center  
Fax: 81-3-5639-7507  
Email: [jpn.feedback@nsc.com](mailto:jpn.feedback@nsc.com)  
Tel: 81-3-5639-7560