



AIC1732

300mA Low Dropout Linear Regulator

FEATURES

- Low Dropout Voltage of 130mV at 100mA Output Current (5.2V Output Version).
- Guaranteed 300mA Output Current.
- Internal 1.3Ω P-MOSFET Draws no Base Current.
- Low Ground Current at 55μA.
- 2% Accuracy Output Voltage of 3.3V/ 3.4V/ 3.5V/ 3.6V/ 3.7V/ 3.8V/ 5.0V/ 5.2V.
- Input Voltage Range up to 12V.
- Needs only 1μF for Stability.
- Current and Thermal Limiting.

APPLICATIONS

- Voltage Regulator for CD-ROM Drivers.
- Voltage Regulator for LAN Cards.
- Voltage Regulator for Microprocessor.
- Wireless Communication Systems.
- Battery Powered Systems.

DESCRIPTION

The AIC1732 is a 3-pin low dropout linear regulator. The superior characteristics of the AIC1732 include zero base current loss, very low dropout voltage, and 2% accuracy output voltage. Typical ground current remains approximately 55μA, from no load to maximum loading conditions. Dropout voltage at 100mA output current is exceptionally low: 130mV for the AIC1732-50 and AIC1732-52, 180mV for the AIC1732-33, AIC1732-34, AIC1732-35, AIC1732-36, AIC1732-37 and AIC1732-38. Output current limiting and thermal limiting are built in to provide maximal protection to the AIC1732 against fault conditions.

The AIC1732 comes in the popular 3-pin SOT-89 packages.

TYPICAL APPLICATION CIRCUIT

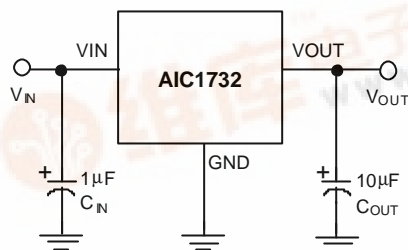

Low Dropout Linear Regulator



ORDERING INFORMATION

AIC1732-XXXXX

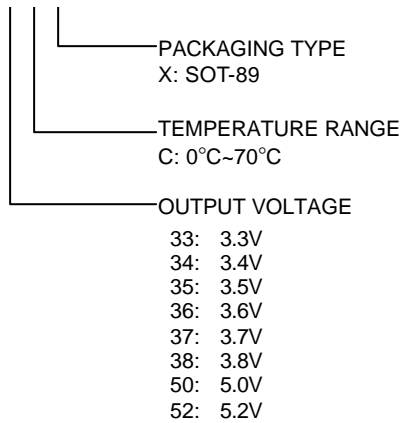

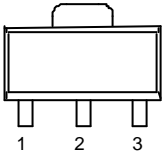
ORDER NUMBER	PIN CONFIGURATION
AIC1732-33CX AIC1732-34CX AIC1732-35CX AIC1732-36CX AIC1732-37CX AIC1732-38CX AIC1732-50CX AIC1732-52CX SOT-89	FRONT VIEW 1: GND 2: VIN 3: VOUT 

ABSOLUTE MAXIMUM RATINGS

Input Supply Voltage.....	-0.3~12V
Operating Junction Temperature Range	-40°C~ 125°C
Storage Temperature Range	-65°C~150°C
Power Dissipation	SOT-89 Package 0.5W

TEST CIRCUIT

Refer to the TYPICAL APPLICATION CIRCUIT

ELECTRICAL CHARACTERISTICS (Ta=25°C, C_{IN}=1mF, C_{OUT}=10mF, unless otherwise specified.)

PARAMETER	TEST CONDITIONS	MIN.	TYP.	MAX.	UNIT	
Output Voltage	No Load				V	
	AIC1732-52	V _{IN} =5.5~12V	5.100	5.2		5.300
	AIC1732-50	V _{IN} =5.5~12V	4.900	5.0		5.100
	AIC1732-38	V _{IN} =4.1~12V	3.725	3.8		3.875
	AIC1732-37	V _{IN} =4.0~12V	3.625	3.7		3.775
	AIC1732-35	V _{IN} =4.0~12V	3.430	3.5		3.570
	AIC1732-33	V _{IN} =3.6~12V	3.235	3.3		3.365
Output Voltage Temperature Coefficiency	(Note 1)		50	150	PPM/°C	

■ ELECTRICAL CHARACTERISTICS (Continued)

PARAMETER	TEST CONDITIONS	MIN.	TYP.	MAX.	UNIT
Line Regulation	$I_L=1\text{mA}$				
	AIC1732-52 $V_{IN}=5.5\sim 12\text{V}$		5	15	mV
	AIC1732-50 $V_{IN}=5.5\sim 12\text{V}$		5	15	
	AIC1732-38 $V_{IN}=4.1\sim 12\text{V}$		5	15	
	AIC1732-37 $V_{IN}=4.0\sim 12\text{V}$		5	15	
	AIC1732-35 $V_{IN}=4.0\sim 12\text{V}$		5	15	
AIC1732-33 $V_{IN}=3.6\sim 12\text{V}$		5	15		
Load Regulation (Note 2)	AIC1732-52 $V_{IN}=7\text{V}, I_L=0.1\sim 300\text{mA}$		15	40	mV
	AIC1732-50 $V_{IN}=7\text{V}, I_L=0.1\sim 300\text{mA}$		15	40	
	AIC1732-38 $V_{IN}=5\text{V}, I_L=0.1\sim 300\text{mA}$		15	40	
	AIC1732-37 $V_{IN}=5\text{V}, I_L=0.1\sim 300\text{mA}$		15	40	
	AIC1732-35 $V_{IN}=5\text{V}, I_L=0.1\sim 300\text{mA}$		15	40	
	AIC1732-33 $V_{IN}=5\text{V}, I_L=0.1\sim 300\text{mA}$		15	40	
Current Limit (Note 3)	AIC1732-52 $V_{IN}=7\text{V}, V_{OUT}=0\text{V}$	300	440		mA
	AIC1732-50 $V_{IN}=7\text{V}, V_{OUT}=0\text{V}$	300	440		
	AIC1732-38 $V_{IN}=7\text{V}, V_{OUT}=0\text{V}$	300	440		
	AIC1732-37 $V_{IN}=5\text{V}, V_{OUT}=0\text{V}$	300	440		
	AIC1732-35 $V_{IN}=5\text{V}, V_{OUT}=0\text{V}$	300	440		
	AIC1732-33 $V_{IN}=5\text{V}, V_{OUT}=0\text{V}$	300	440		
Dropout Voltage (Note 4)	AIC1732s $I_L=0.1\text{mA}$		0.2	10	mV
	AIC1732-52 $I_L=300\text{mA}$		400	500	
	AIC1732-50 $I_L=300\text{mA}$		400	500	
	AIC1732-38 $I_L=300\text{mA}$		540	640	
	AIC1732-37 $I_L=300\text{mA}$		540	640	
	AIC1732-35 $I_L=300\text{mA}$		540	640	
	AIC1732-33 $I_L=300\text{mA}$		540	640	
	AIC1732-33 $I_L=300\text{mA}$		540	640	
Ground Current	$I_O=0.1\text{mA}\sim I_{MAX}$				
	AIC1732-52 $V_{IN}=5.5\sim 12\text{V}$		55	80	μA
	AIC1732-50 $V_{IN}=5.5\sim 12\text{V}$		55	80	
	AIC1732-38 $V_{IN}=4\sim 12\text{V}$		55	80	
	AIC1732-37 $V_{IN}=4\sim 12\text{V}$		55	80	
	AIC1732-35 $V_{IN}=4\sim 12\text{V}$		55	80	
	AIC1732-33 $V_{IN}=4\sim 12\text{V}$		55	80	

Note 1: Guaranteed by design.

Note 2: Regulation is measured at constant junction temperature, using pulse testing with a low ON time.

Note 3: Current limit is measured by pulsing a short time.

Note 4: Dropout voltage is defined as the input to output differential at which the output voltage drops 100mV below the value measured with a 1V differential.

TYPICAL PERFORMANCE CHARACTERISTICS

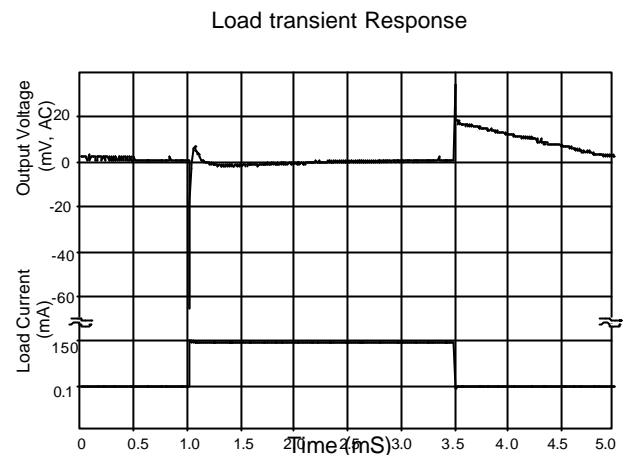
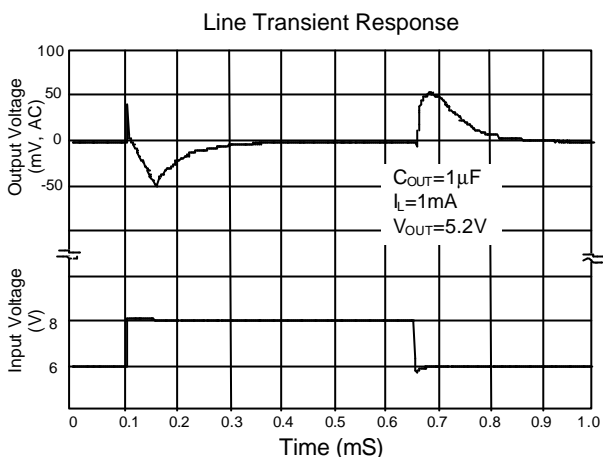
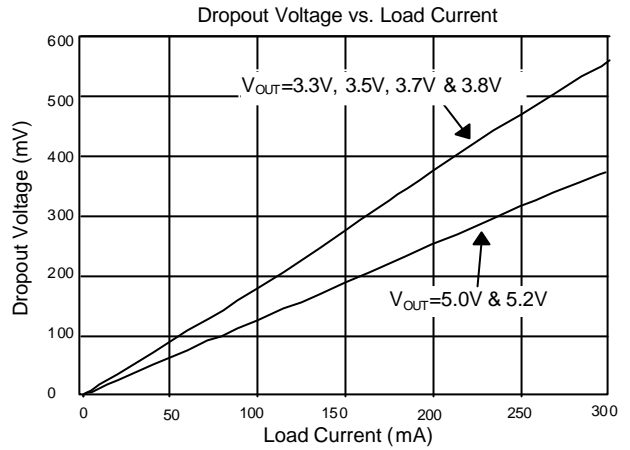
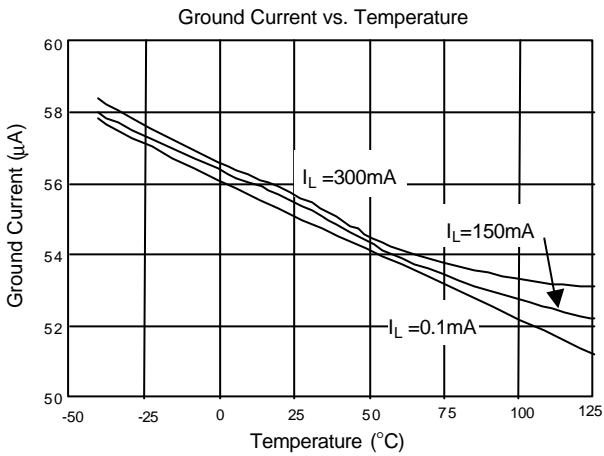
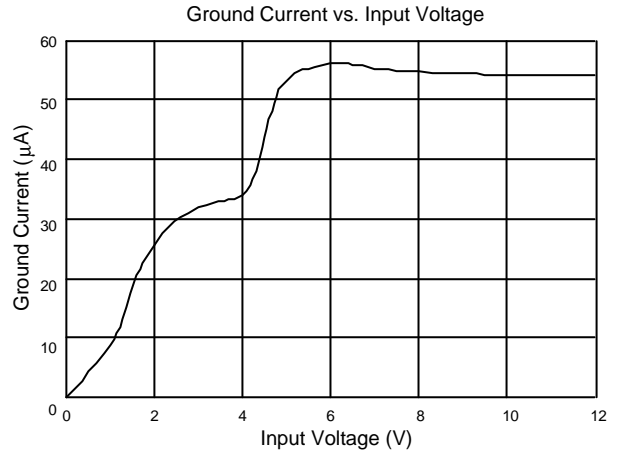
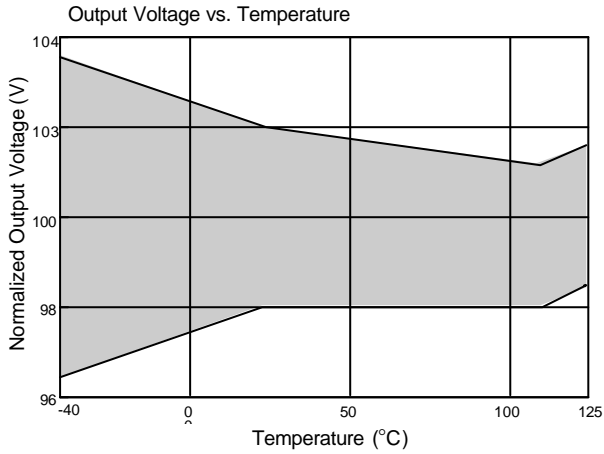

TYPICAL PERFORMANCE CHARACTERISTICS (Continued)

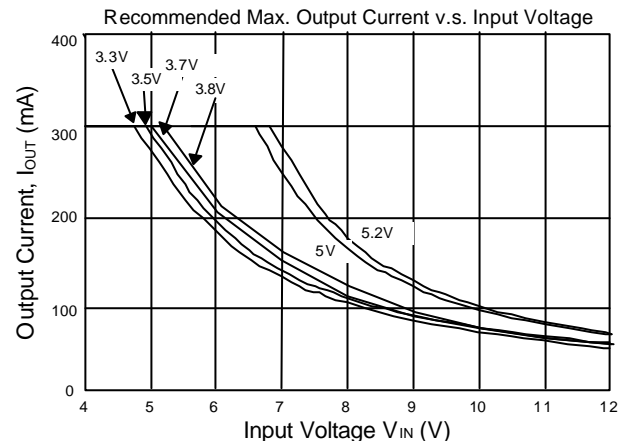
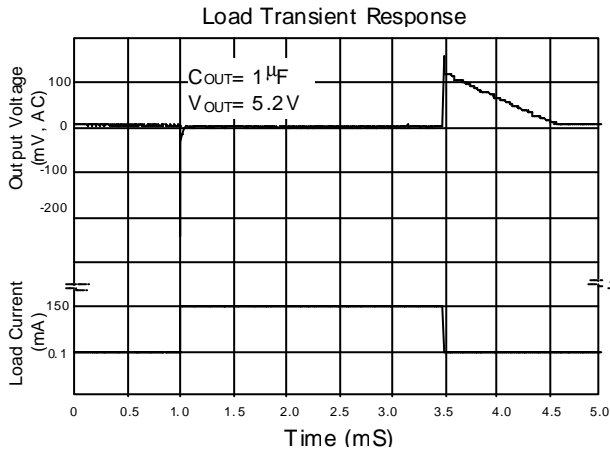

BLOCK DIAGRAM

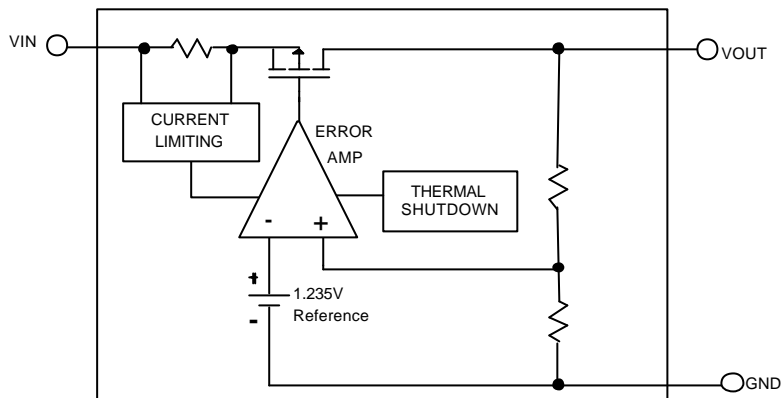

PIN DESCRIPTION

V_{OUT} PIN - Output pin.

GND PIN - Power GND.

V_{IN} PIN - Power Supply Input.

APPLICATION INFORMATIONS

A $1\mu F$ (or greater) capacitor is required between the AIC1732 output and ground for stability. Without this capacitor the part will oscillate. Even though most types of capacitor may work, the equivalent series resistance (ESR) should be held to 5Ω or less if Aluminum electrolytic type is used. Many Aluminum electrolytics have electrolytes that freeze at about $-30^\circ C$, so solid tantalums are recommended for operation below $-25^\circ C$. The

value of this capacitor may be increased without limit.

A $0.1\mu F$ capacitor (or greater) should be placed from the AIC1732 input to ground if the lead inductance between the input and power source exceeds $500nH$ (approximately 10 inches of trace).

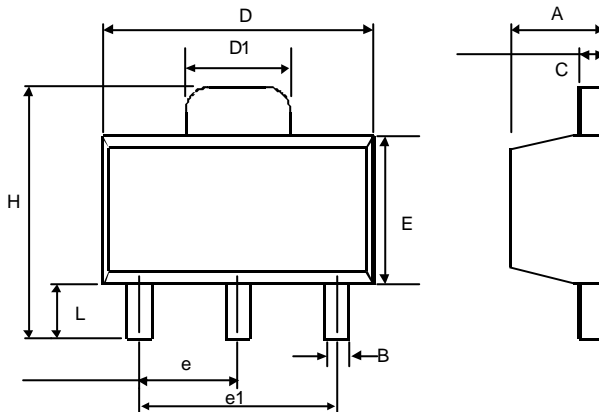
■ PHYSICAL DIMENSIONS
● SOT-89 (unit: mm)

SYMBOL	MIN	MAX
A	1.40	1.60
B	0.36	0.48
C	0.35	0.44
D	4.40	4.60
D1	1.62	1.83
E	2.29	2.60
e	1.50 (TYP.)	
e1	3.00 (TYP.)	
H	3.94	4.25
L	0.89	1.20

● SOT-89 MARKING

Part No.	Marking
AIC1732-33	AR33
AIC1732-34	AR34
AIC1732-35	AR35
AIC1732-36	AR36
AIC1732-37	AR37
AIC1732-38	AR38
AIC1732-50	AR50
AIC1732-52	AR52