

240 Watts

AK80A

Total Power: 240 Watts
Input Voltages: 24V
No. of Outputs: Single



Electrical Specs

Input

Input Range	18 to 36 VDC
Efficiency	83% typical (5V @ 40A); 87% typical (12V @ 18A); 87% typical (15V @ 16A)

Output

Load Regulation	0.3% typical down to no load
Line Regulation	0.1% typical
Noise/Ripple	100 mV typical (output below 5V) 2% typical (output 5V and over)
Remote sense	Up to 0.5V
Output Voltage	
Adjust Range	±10% of nominal output
Transient Response	10% typical deviation with 300µs recovery (25-75% full load)
Current Share Accuracy	5% typical
Overvoltage Protection	130% nominal Vo
Current Limit	115% Io max

Control

Voltage Adjust	90 to 110% Vo
Enable	TTL compatible (low to enable)
Current Limit Adjust	20 to 100% Io rated
Clock Input (external sync)	3.5 to 5Vp-p @ 1MHz ± 10%
Clock Output (internal clock)	4.4 to 5.5Vp-p @ 1MHz ± 0.5%
Power	
Good/Identification	High (Vo) = power good
Temperature	
Monitor Output	10 mV/°K (2.73V = 0°C)

Notes

Nominal values apply with sense pins connected and other control pins unconnected.

Specifications subject to change without notice.

Special Features

- High efficiency - up to 87%
- 500 KHz fixed frequency
- 85°C baseplate operating temperature (with no derating)
- Low output ripple and noise
- Excellent transient response
- High reliability - over 1 million hours MTBF
- Wide input voltage range
- TTL compatible enable control
- Parallelable
- Adjustable output voltage and current limit
- Temperature monitor output
- Overtemperature and short circuit protection
- Regulation to zero load

Environmental

Operating temperature (baseplate):

0°C to +85°C

Storage temperature: -40°C to +105°C

Overtemperature protection: 90°C typical

MTBF: > 1 million hours (50°C baseplate)

Safety

UL	UL 1950	E132002
CSA	CSA22.2-234	LR53982C
	CSA22.2-950	
VDE	IEC950	20366-3336-1002 & 1008
EN	60950	
CE	CEMark (LVD)	

AMERICAS

5810 Van Allen Way
Carlsbad, CA 92008
Telephone: 760-930-4600
Facsimile: 760-930-0698

EUROPE

Astec House, Waterfront Business Park
Merry Hill, Dudley
West Midlands, DY5 1LX, UK
Telephone: 44 (1384) 842-211
Facsimile: 44 (1384) 843-355

ASIA

Units 2111-2116, Level 21
Tower1, Metroplaza
223, Hing Fong Road
Fwai Fong, New Territories
Hong Kong
Telephone: 852-2437-9662
Facsimile: 852-2402-4426



AK80A

Ordering Information

Input Voltage	Output Voltage	Output Current	Model Number
24V	3.3V	40A	AK80A-024L-033F40
24V	5V	30A	AK80A-024L-050F30
24V	12V	14A	AK80A-024L-120F14
24V	15V	12A	AK80A-024L-150F12
24V	24V	8A	AK80A-024L-240F08

Please contact Astec for information on other output voltages, power ranges and configurations.

Pin Assignments

Input	Output	Control Pins
31. +ve	21. +ve	1. +SENSE
32. -ve	22. +ve	2. PG/ID
	23. +ve	3. V ADJ
	24. +ve	4. -SENSE
	26. -ve	5. S COM
	27. -ve	6. C SHARE
	28. -ve	7. CLK OUT
	29. -ve	8. CLK IN
		9. ENABLE
		10. C LIM ADJ
		11. TEMP MON
		12. PRI AUX

Secondary side controls

Primary side controls

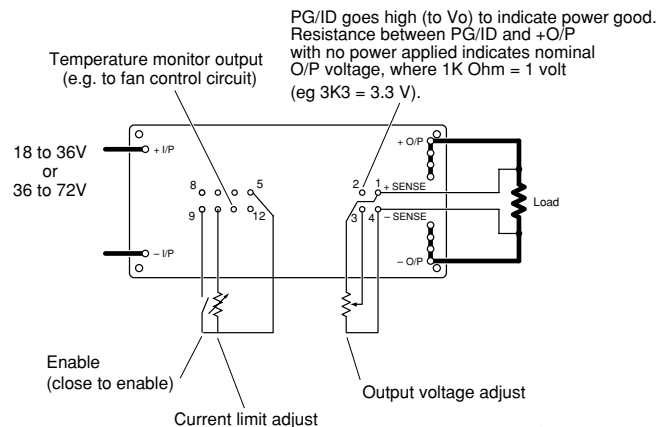
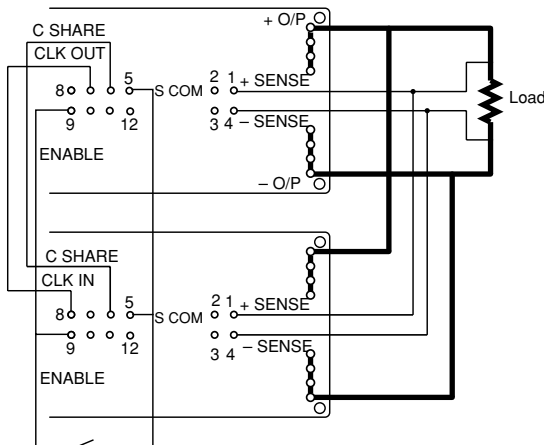
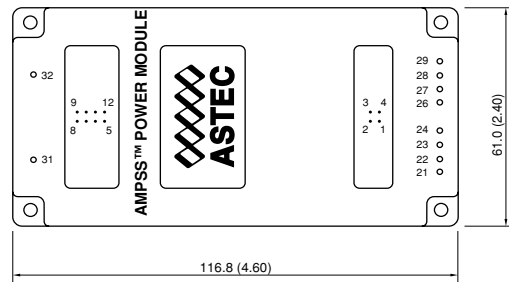
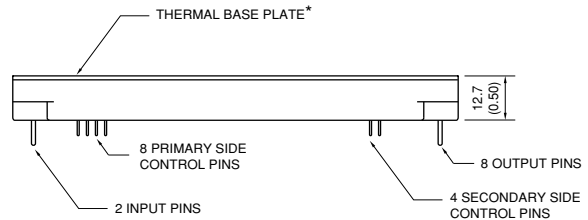

Astec Integrated Power