

LAN COUPLING TRANSFORMERS

FAST ETHERNET & GIGABIT SERIES

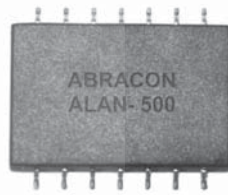

➤ STANDARD SPECIFICATIONS:

FAST ETHERNET TRANSFORMERS											
Part Number ¹	Turns Ratio ^{3,4} (±2%)	I _L (dB) MHz (max)	R _L (dB) MHz (min)			CMR _(dB) MHz (min) .1-100	X-Talk (dB) MHz (min)			Cir	Pkg
			.1-30	30-50	50-80		1.0-30	30-60	60-100		
APT-104	1CT:1CT	1.1	20	14	11.5	33	42	37	33	1	A
ALAN-101	1CT:1CT	1.1	18	15	13	30	42	38	35	1	A
ALAN-102	1CT:1CT	1.1	18	15	13	30	42	38	35	2	A
ALAN-103	1CT:2CT	1.1	18	13	13	30	42	38	35	1	A
ALAN-104	1CT:1.41CT	1.1	18	13	13	30	42	38	35	1	A
ALAN-108	1CT:1CT	1.0	22	18	12	32	50	40	40	3	C
ALAN-113	1CT:1CT	1.0	20	18	14	33	50	40	40	4	C
ALAN-114	1CT:1CT	1.2	16	13	12	30	43	37	33	5	D
ALAN-117	1CT:1CT	1.0	22	20	12	35	50	40	40	1	C
ALAN-121	1CT:1CT	1.2	18	13	12	42	44	40	38	6	B
ALAN-122	1CT:1CT	1.2	16	13	12	38	44	40	38	7	B
ALAN-123	1CT:2CT	1.2	16	13	12	35	44	40	38	7	B
ALAN-124	1CT:1.41CT	1.2	16	13	12	42	44	40	38	6	B
ALAN-125	1CT:41CT	1.2	16	13	12	38	44	40	38	7	B
ALAN-131	1CT:1CT	1.1	18	14	12	35	45	42	40	4	C
ALAN-132	1CT:1.41CT	2.0	18	12	11	34	45	38	34	4	C
ALAN-133	1CT:1CT	1.0	20	16	13	35	45	40	38	20	C
ALAN-134	1CT:1CT	1.0	18	14.4	12	25	55	45	33	21	A
ALAN-407	1CT:1CT	1.0	18	12	10	30	33	30	28	11	D
ALAN-414	1CT:1CT	1.1	18	15.5	10	40	38	38	38	11	D
ALAN-415	1CT:1CT	1.0	18	14.4	12	25	55	40	33	22	D
ALAN-501	1CT:1CT	1.1	18	15	11	30	45	38	35	8	E
ALAN-502	1CT:1.41CT	1.1	18	15	11	30	45	38	35	8	E
ALAN-503	1CT:1CT	1.1	18	15	11	30	45	38	35	9	F
ALAN-504	1CT:1.41CT	1.1	18	15	11	30	45	38	35	9	F
ALAN-505	1CT:1CT	1.0	16	12	11	20	50	45	40	10	G

GIGABIT MODULES											
Part Number ¹	Turns Ratio ^{3,4} (±2%)	I _L (dB) MHz (max)	R _L (dB) MHz (min)			CMR _(dB) MHz (min) .1-100	X-Talk (dB) MHz (min)			Cir	Pkg
			.1-30	30-50	50-80		1.0-30	30-60	60-100		
ALAN-1001	1CT:1.41CT	1.1	18	13	12	40	45	40	38	11	D
ALAN-1002	1CT:1.41CT	1.1	18	13	12	40	45	40	38	11	D

FAST ETHERNET TRANSFORMERS											
Part Number ¹	Turns Ratio ^{3,4} (±2%)	I _L (dB) MHz (max)	R _L (dB) MHz (min)			CMR _(dB) MHz (min) .1-100	X-Talk (dB) MHz (min)			Cir	Pkg
			.1-30	30-50	50-80		1.0-30	30-60	60-100		
ALAN-401	1CT:1.41CT	1.1	18	13	12	40	45	40	38	13	H
ALAN-402	1CT:1.41CT	1.1	18	13	12	40	45	40	38	14	H
ALAN-405	1CT:2CT	1.0	18	12	10	30	42	40	30	13	H
ALAN-406	1CT:1CT	1.0	21	14	12	30	55	45	35	14	H
ALAN-408	1CT:1CT	1.0	18	13	12	30	55	45	35	15	H
ALAN-409	1CT:1CT	1.0	18	13	12	25	45	40	33	16	H
ALAN-410	1CT:1CT	1.1	21	14	12	30	50	40	30	17	H
ALAN-411	1CT:1CT	1.0	21	14	12	30	55	45	35	18	H
ALAN-412	1CT:1CT	1.1	21	14	12	40	55	45	35	19	H



LAN COUPLING TRANSFORMERS

ABRACON
ALAN-400

FAST ETHERNET & GIGABIT SERIES

TEST CONDITIONS:

A. OCL: 100 mV_{RMS} @ 100 KHz with 8 mA DC

B. R_L/L measurements assume 100Ω media interface

C. Bias: 8 mA (minimum) steady state DC

D. DWV: 1,500 V_{RMS} for 1 minute min; greater isolation voltage available

NOTES:

1. P/Ns with "T" as suffix are configured for through-hole applications

2. Dual port design configuration

3. Turns ratios are specified: "transceiver : media" with ±2% tolerance

4. "CT" indicates a center-tapped winding, otherwise readings are intended to be across entire winding segment

5. OCL for 10/100Base-T and Gigabit applications is specified at: 350 μH min with 8mA bias measured from the media interface and -40°C to 85°C

CIRCUITS:

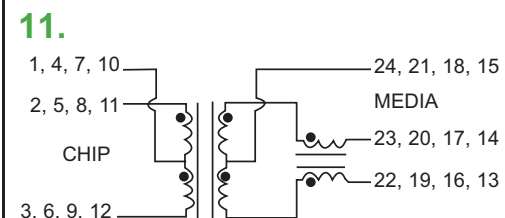
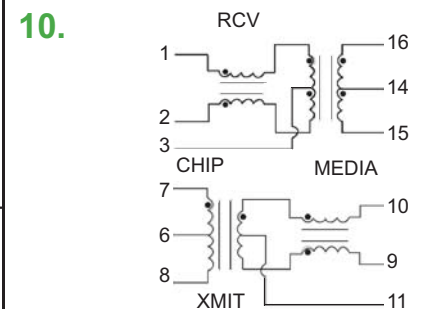
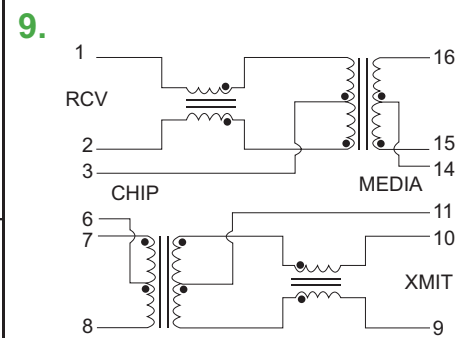
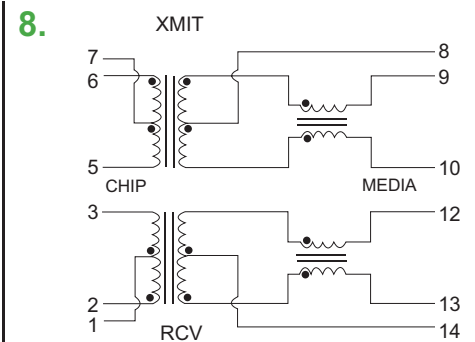
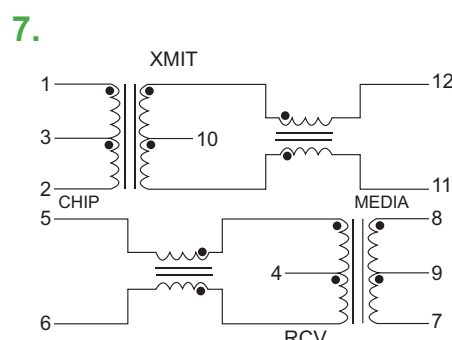
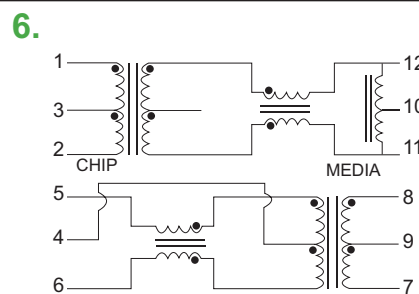
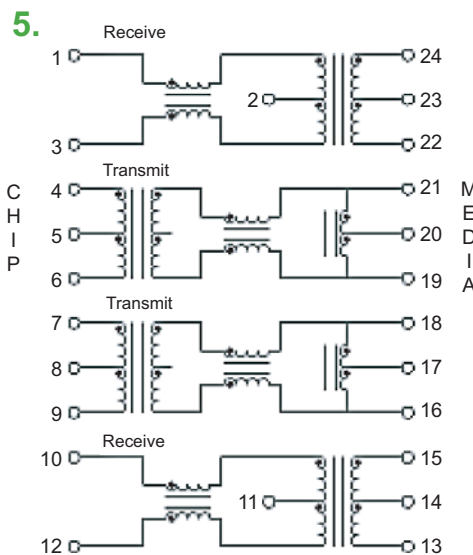
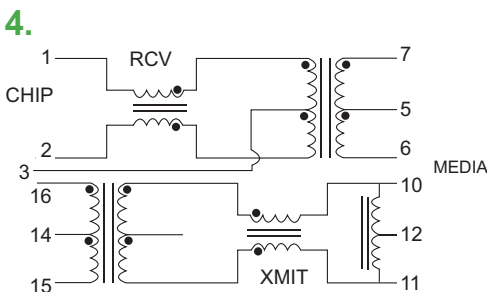
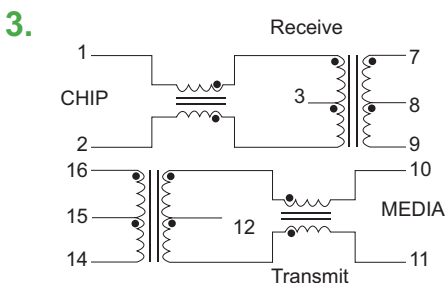
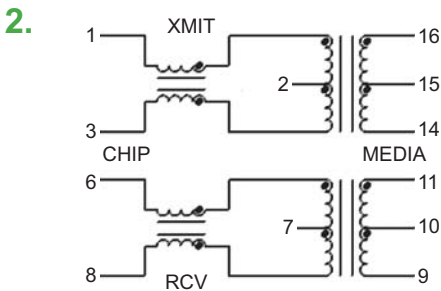
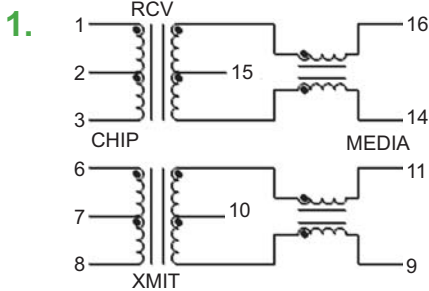

LAN COUPLING TRANSFORMERS

FAST ETHERNET & GIGABIT SERIES



CIRCUITS:

12.

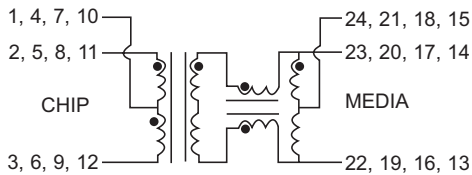

13.

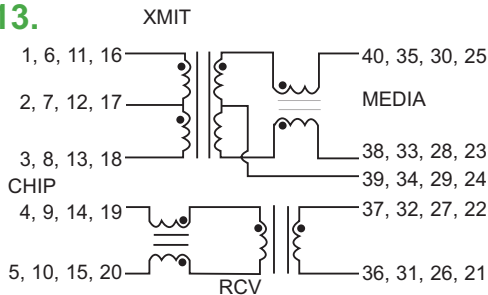

14.

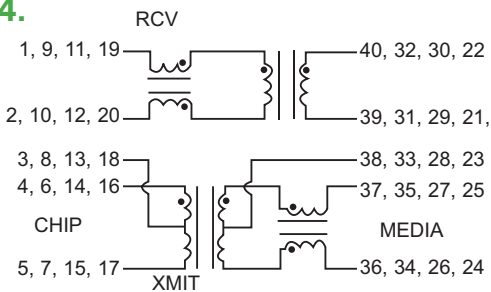

15.

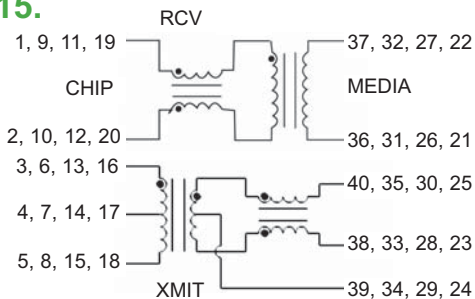

16.

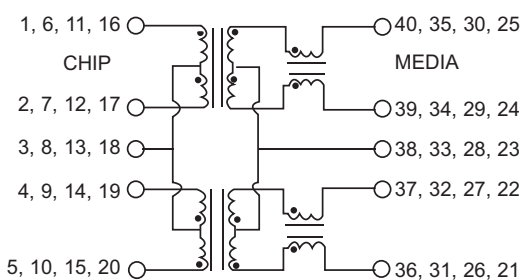

17.

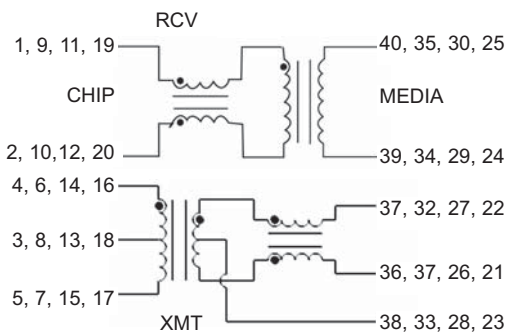

19.

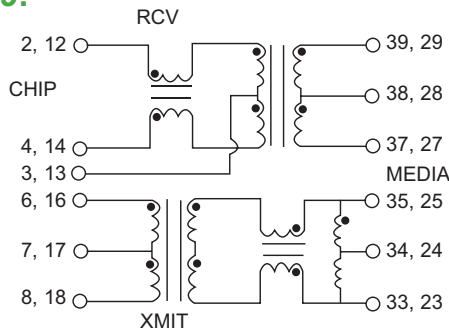

21.

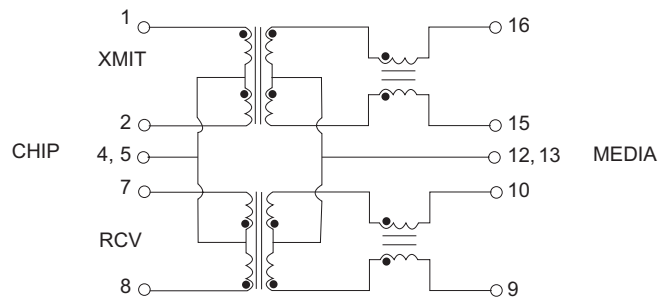

22.

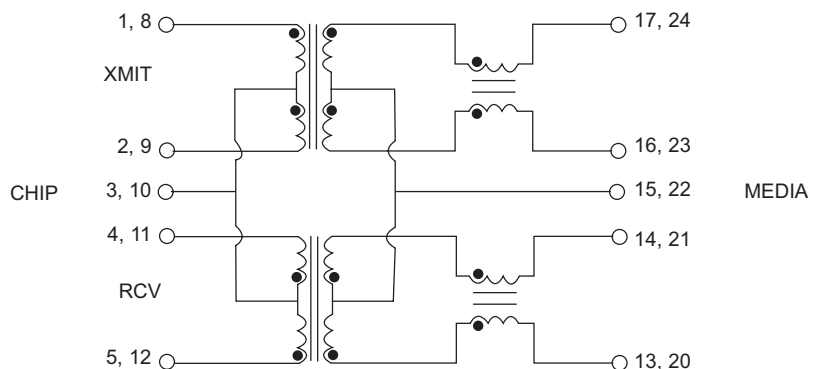

LAN COUPLING TRANSFORMERS

FAST ETHERNET & GIGABIT SERIES



NOTES:

- 7. Dimensions: inches / mm; see spec sheet for tolerance limits
- 8. Specifications subject to change without notice

PACKAGES:

A.

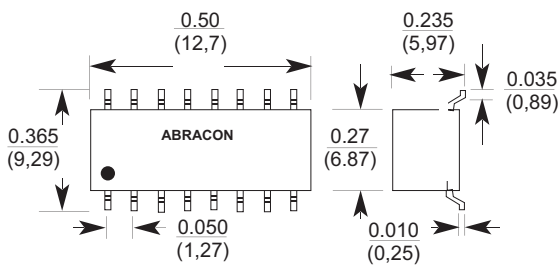

B.

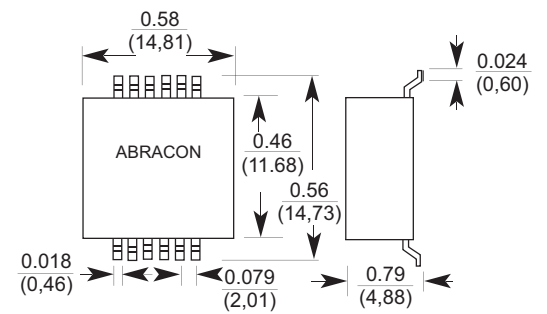

C.

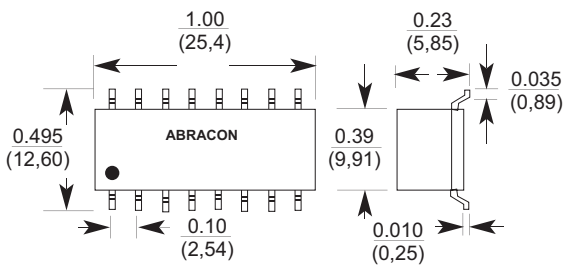

D.

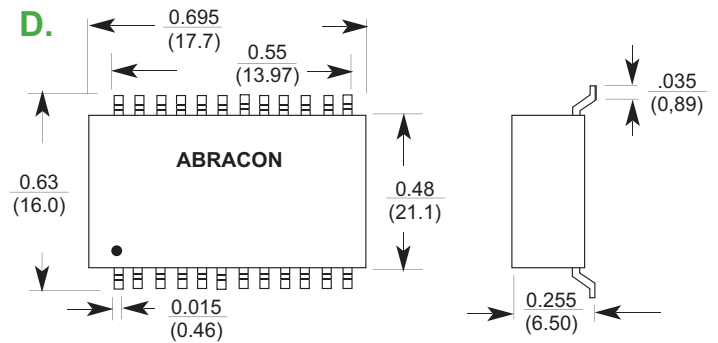

E.

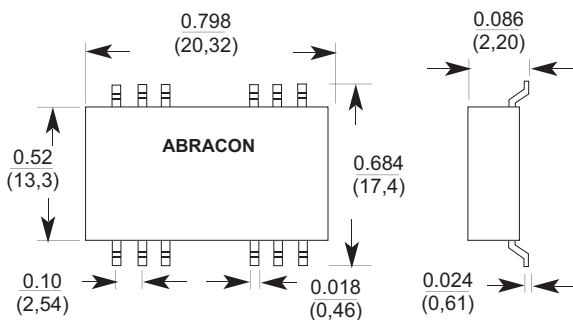

F.

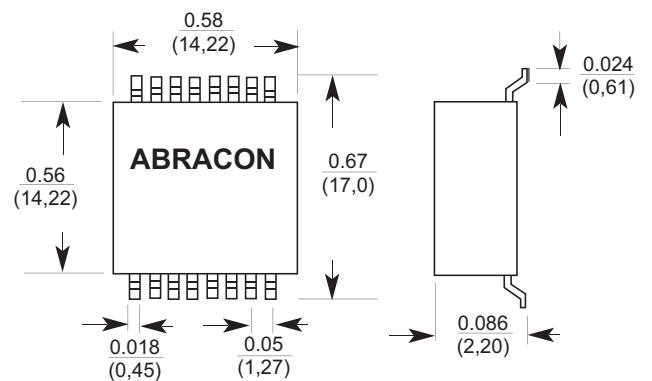

G.

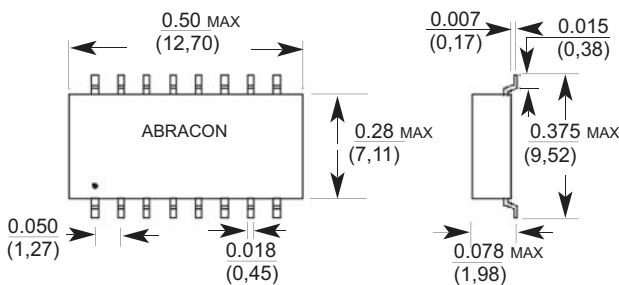

H.

