

acut**technology**

AQ102

Low-Voltage Ref/Amplifier SOT23-5 and SC70-5 Package

Product Specification

Revision 1.3

May 3, 2005

General Description

The AQ102 is a low voltage combined reference/amplifier suited for the control loop of low voltage power supplies. In order to allow operation down to very low voltages, the error amplifier output and the supply terminal have been isolated to separate functional pins. The nominal reference voltage is 600 mV, the COMP output can sink 20mA at 300mV.

Functionally, the AQ120 can be applied similarly to industry standard TL431, except that the reference is 600 mV and this requires a separate Vcc connection to a supply above 2.2V. Additionally, the output of the AQ120 can swing close to ground.

In the SC-70 package, the AQ102 is a replacement for the MAX8515 part.

Applications

- Power supply control loop
- Power supply supervisory functions

Features

- Low input voltage reference
- 600mV high accuracy voltage reference
- Low TC voltage reference
- High PSRR and line regulation
- Low current consumption
- Offered in ultra small SC70-5 package
- Zero offset error amplifier
- Open collector output
- **RoHS compliant**

Block Diagram

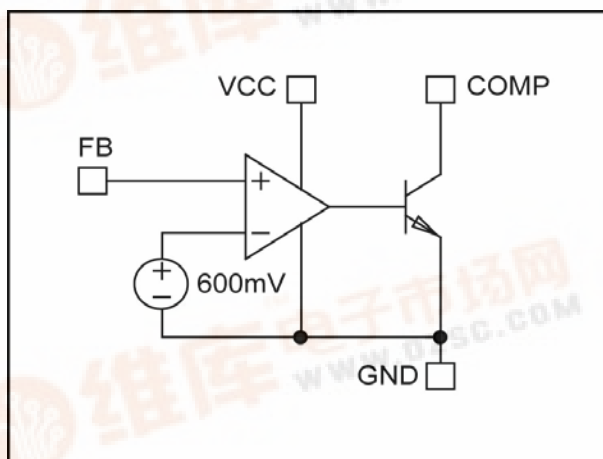

Pin Configuration

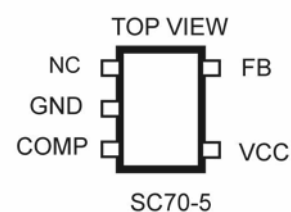
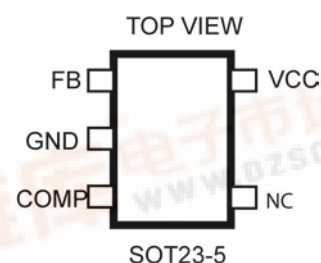

Typical Application

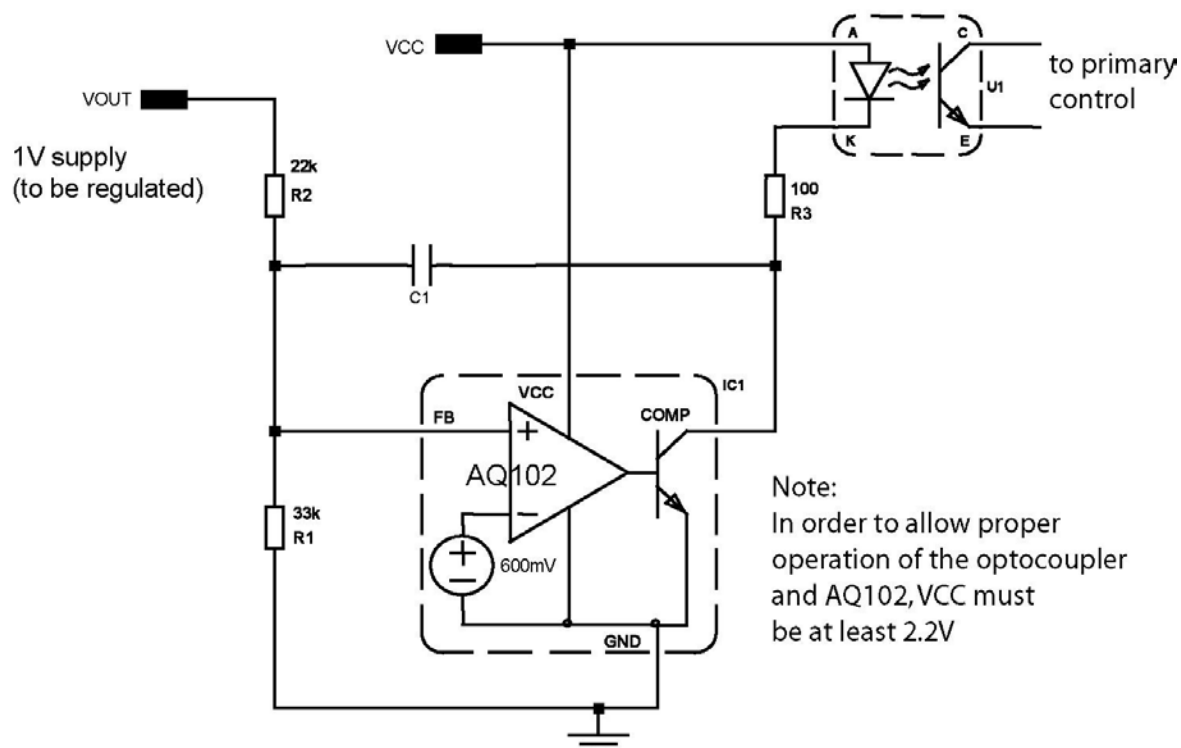

Pin Descriptions

Pin	Pin Name	Function
1	FB	Inverting input to error amplifier; will have threshold of 600mV.
2	GND	Ground
3	COMP	Output of error amplifier; 20 mA source/sink capability
4	N/C	-
5	VCC	Positive supply

Ordering Information

Device	Operating Tj	%Tol	Pkg Type	VOUT	Wrap	Ordering Number
AQ102	-40°C ≤ 105°C	1.0	SOT-23-5	0.6V	T&R	AQ102BY-M5-06-TRL
AQ102	-40°C ≤ 105°C	1.0	SC70-5	0.6V	T&R	AQ102BY-C5-06-TRL

Note: The TRL parts are Lead Free and RoHS compliant.

Absolute Maximum Ratings

Parameter	Value	Units
V _{CC} Voltage	20	V
COMP Voltage	20	V
REF Voltage	20	V
VCC, COMP, REF Current	50	mA
Operating Junction Temperature	150	°C
Lead Temperature (soldering 10 seconds)	260	°C
Storage Temperature Range	-65 to +150	°C

Electrical Specifications

Electrical characteristics are guaranteed over the full temperature range $-40^{\circ}\text{C} < T_j < 105^{\circ}\text{C}$. Ambient temperature must be de-rated based upon power dissipation and package thermal characteristics. Unless otherwise stated, test conditions are VCC = 3V, VCOMP = VFB, ICOMP = 1mA

Symbol	Parameter	Conditions	Min	Typ	Max	Units
Vccmin	Minimum Input Voltage				2.2	V
Icc	Quiescent Supply Current	VCOMP=1V		0.3	0.5	mA
Vcc	Supply Voltage		2.2		18	V
Vref	Reference Voltage	T _j =25°C	594	600	606	mV
		-40°C < T _j < 105°C	592		608	
DVcc	Line regulation	2.2V < VCC < 18V		0.5	1	mV
DViload	Load Regulation	ICOMP=1mA to 10mA		4	8	mV
Tcref	Reference Temperature Deviation	-40°C < T _j < 105°C		25	50	ppm/°C
IFB	REF input current		-500		500	nA
PSRR	Reference Power Supply Rejection	Freq.=300KHz	35	45		dB
Av	Error Amplifier Open Loop Gain	ICOMP=2mA, COMP=1V	60	80		dB
BW	Unity Gain Frequency	ICOMP=2mA, COMP=1V	1	2		MHz
VCOMP	Output Saturation Voltage	ICOMP=20mA, VFB=700mV		100	250	mV
TRANSC	Output Transconductance	ICOMP=1mA to 20mA		2.5		mA/mV
Ileak	Output Leakage Current	VCOMP=16 VFB=0		200	400	nA

Typical Performance Characteristics

Line regulation (at 1mA)

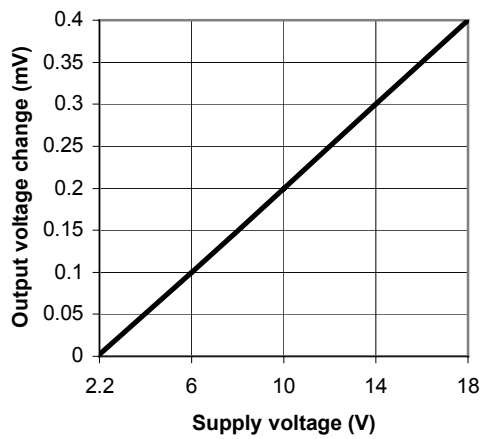

Load regulation

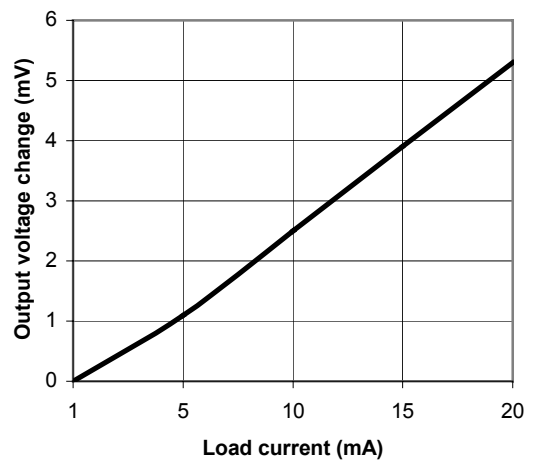

Supply current vs load current

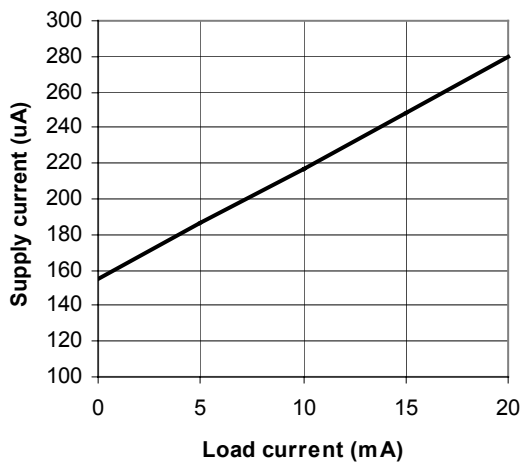

Power-supply rejection ratio vs frequency

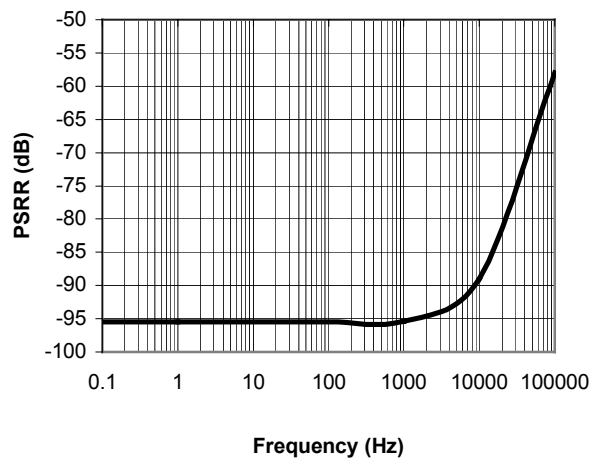

Typical Performance Characteristics (contd.)

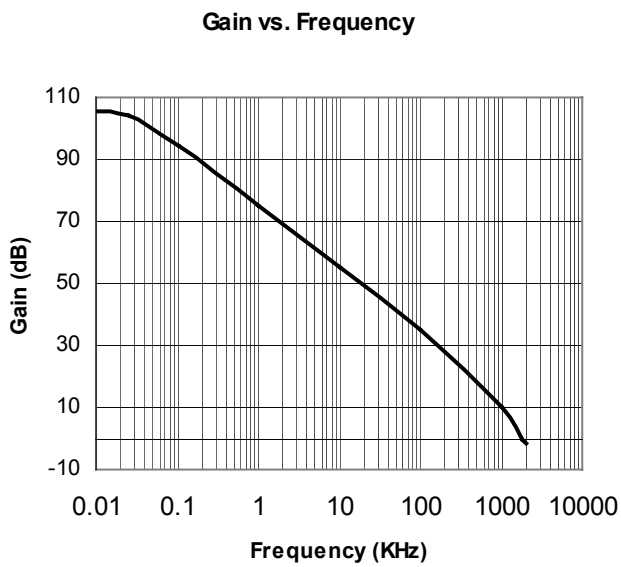
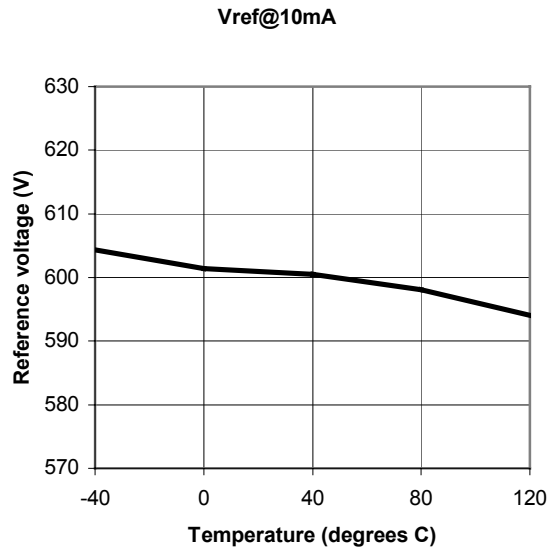
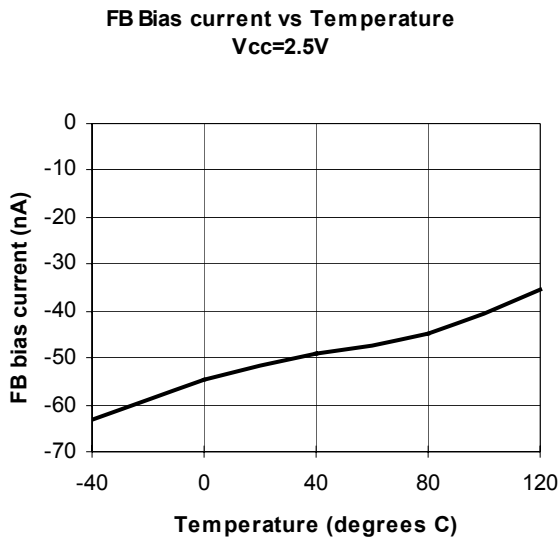

Package Dimensions

SOT23-3, SOT23-4, SOT23-5, SOT23-6

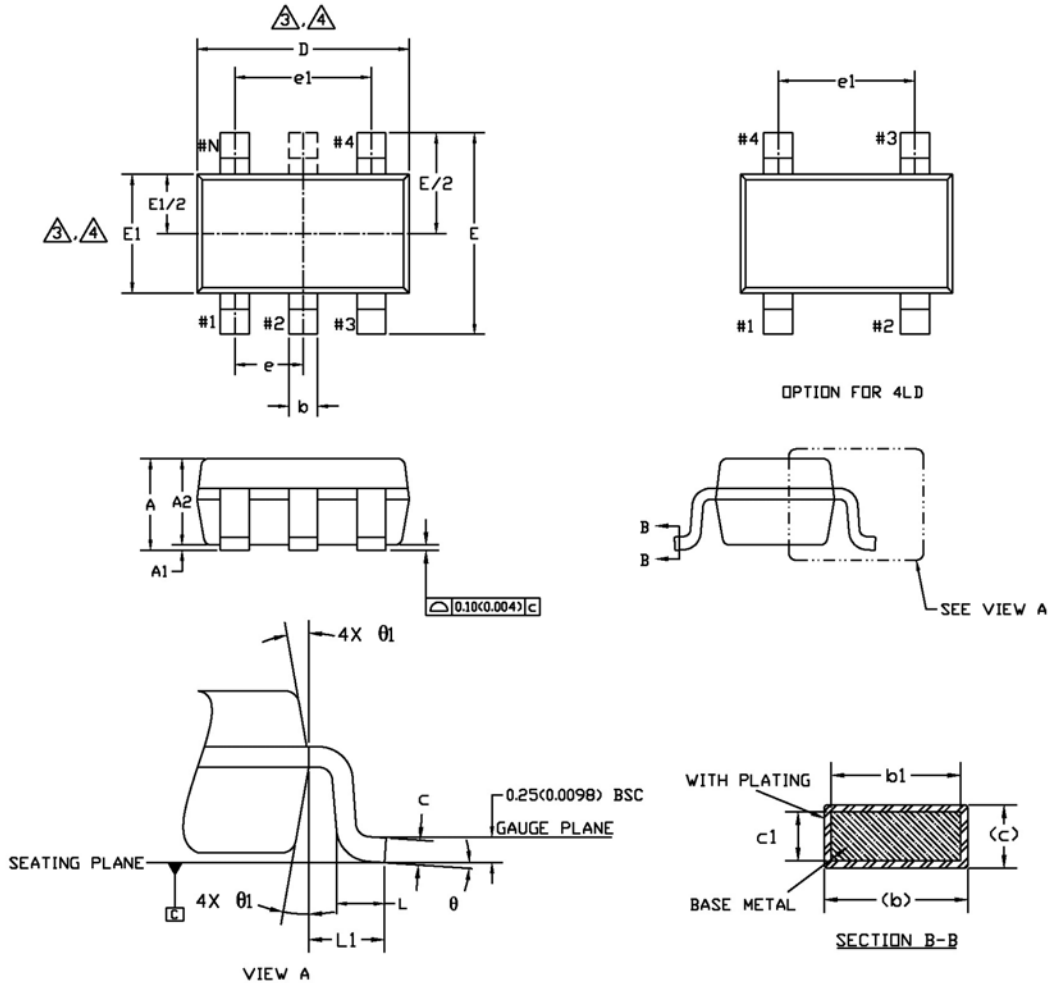

SYMBOL	COMMON					
	DIMENSIONS MILLIMETER			DIMENSIONS INCH		
	MIN.	NOM.	MAX.	MIN.	NOM.	MAX.
A	1.20	1.30	1.40	0.047	0.051	0.055
A1	0.05	-	0.15	0.002	-	0.006
A2	0.90	1.15	1.30	0.035	0.045	0.051
b	0.35	-	0.50	0.013	-	0.020
b1	0.35	0.40	0.45	0.013	0.015	0.017
c	0.08	-	0.22	0.003	-	0.008
c1	0.08	0.13	0.20	0.003	0.005	0.007
D	2.90 BSC			0.114 BSC		
E	2.80 BSC			0.110 BSC		
E1	1.60 BSC			0.062 BSC		
e	0.95 BSC			0.037 BSC		
e1	1.90 BSC			0.074 BSC		
L	0.35	0.45	0.55	0.013	0.017	0.021
L1	0.60 REF.			0.023 REF.		
theta	0°	4°	8°	0°	4°	8°
theta1	10° TYP			10° TYP		

NOTE :

1. Dimensioning and tolerancing per ASME Y 14.5 M - 1994.
2. Dimensions are in millimeters. Converted inch dimension are not necessarily exact.
3. Dimension D does not include mold flash, protrusions or gate burrs. Mold flash, protrusion or gate burrs shall not exceed 0.15 mm per side. Dimension E1 does not include interlead flash or protrusion. Interlead flash or protrusion shall not exceed 0.15 mm per side.
4. Top package may be smaller than the bottom package. Dimension D and E1 are determine at the outermost extremes of the plastic body exclusive of mold flash gate burrs and interlead flash.
5. Terminal numbers are shown for reference only. Die is facing up for molding. Die is facing down for trim/form.

Package Dimensions (contd.)
SC70-3, SC70-4, SC70-5, SC70-6

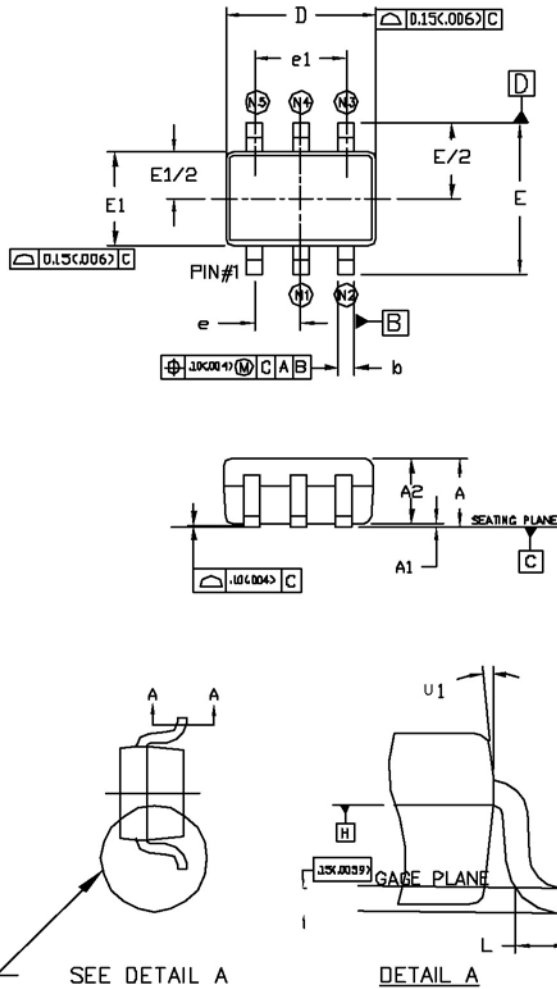

- NOTE :
1. CONTROLLING DIMENSION : MILLIMETER, CONVERTED INCH DIMENSION ARE NOT NECESSARILY EXACT.
 2. DIMENSIONING AND TOLERANCING PER ANSI Y14.5M-1994.
 3. DIMENSION 'D' DOES NOT INCLUDE MOLD FLASH, PROTRUSION OR GATE BURR, MOLD FLASH, PROTRUSION OR GATE BURR SHALL NOT EXCEED 0.15MM(0.006") PER END. DIMENSION E1 DO NOT INCLUDE INTER-LEAD FLASH OR PROTRUSION, INTER-LEAD FLASH OR PROTRUSION SHALL NOT EXCEED 0.15MM (0.006") PER SIDE.
 4. THE PACKAGE TOP BE SMALLER THAN THE PACKAGE BOTTOM. DIMENSION D AND E1 ARE DETERMINED AT THE OUTERMOST EXTREMES OF THE PLASTIC BODY EXCLUSIVE OF MOLD FLASH, TIE BAR BURRS, GATE BURRS AND INTERLEAD FLASH, BUT INCLUDING ANY MISMATCH BETWEEN THE TOP AND BOTTOM OF THE PLASTIC BODY

SYMBOL	COMMON					
	DIMENSIONS MILLIMETER			DIMENSIONS INCH		
	MIN.	NOM.	MAX.	MIN.	NOM.	MAX.
A	0.80	-	1.10	0.031	-	0.043
A1	0	-	0.10	0	-	0.004
A2	0.80	0.90	1.00	0.031	0.035	0.040
b	0.15	-	0.30	0.006	-	0.012
b1	0.15	0.20	0.25	0.006	0.008	0.010
c	0.08	-	0.25	0.003	-	0.010
c1	0.08	0.13	0.20	0.003	0.005	0.008
D	1.90	2.10	2.15	0.074	0.082	0.084
E	2.00	2.10	2.20	0.078	0.082	0.086
E1	1.15	1.25	1.35	0.045	0.050	0.055
e	0.65 BSC			0.0255 BSC		
e1	1.30 BSC			0.0512 BSC		
L	0.26	0.36	0.46	0.010	0.014	0.018
U	0°	-	8°	0°	-	8°
U1	4°	-	10°	4°	-	10°

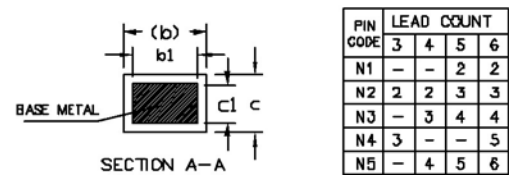

PIN CODE	LEAD COUNT			
	3	4	5	6
N1	-	-	2	2
N2	2	2	3	3
N3	-	3	4	4
N4	3	-	-	5
N5	-	4	5	6

Contact Information

Acutechnology Semiconductor Inc.
 3487 McKee Rd. Suite 52
 San Jose CA , USA 95127

TEL: (408) 259-2300
 FAX: (408) 259-9160
 website: www.acutechnology.com

Disclaimer

The information furnished by Acutechnology in this data sheet is believed to be accurate and reliable. However, Acutechnology assumes no responsibility for its use. Acutechnology reserves the right to change circuitry and specifications at any time without notification to the customer.

Life Support Policy

Acutechnology Products are not designed or authorized for use as components in life support devices or systems where malfunction of a product can reasonably be expected to result in personal injury. Life support devices or systems are devices or systems that (a) are intended for surgical implant into the body or (b) support or sustain life, and whose failure to perform can be reasonably expected to result in a significant injury to the user.